

DEDICATED TO THE LIQUID WASTE INDUSTRY

# Pumper®

October 2022  
pumper.com



## Make it **BETTER**

Luanne and Greg Howland bought a company with a long history of success, and then continued to add building blocks to profitability

Page 20

PRODUCT FOCUS  
**PORTABLE SANITATION,  
OFFICE TECHNOLOGY  
AND SOFTWARE**

Pages 58, 68





**TRICK OR TREAT.** CHECK OUT THE **FLEET.**  
 PolyJohn's quality **CAN'T BE BEAT!**



PolyJohn's Fleet luxury portable restroom is engineered to satisfy the needs of VIP users at special events and other high-end gatherings where premium portable sanitation solutions are essential.

- 24% more interior floor space than other units in its class
- Corner tank allows for most efficient use of interior space
- Easy to clean with sleek interior and exterior surfaces
- Static, Recirculating Flush, Fresh Water Flush, and Mains varieties

**The winner of the Pulitzer Prize Photo Contest will be announced on October 31st!**

Here are a few of the many entries.



Landis Thomas, Potty Man Portables, Georgia



Ryan Granger, Acadian Sanitation, Louisiana



Eric Johnson, Best Septic Service, New Hampshire



**POLYJOHN**  
 there when you need us



**DOWNLOAD OUR GUIDES**

PJProductGuide.com | PJPROReferenceGuide.com

2500 GASPAR AVE., WHITING, IN 46394  
**PJPUMPER.COM | 800.292.1305**



# NVE

National Vacuum Equipment, Inc.



## EVERY YARD NEEDS "THE ONE"

High Vacuum Blower | 1600 cfm

Turn your ordinary pump truck into a **super pumper**. Imagine the possibilities and opportunities that come with 1600 cfm and full vacuum. From hydro-excavation to the deepest, farthest, heaviest pits, never say no to a pump job again!

**Challenger** Series  
VACUUM PUMPS & BLOWERS



Designed. Built. Supported in The USA.

800-253-5500 | [www.natvac.com](http://www.natvac.com)





MADE  
IN THE  
USA



@USTanksIndustry

@USTanksIndustry



**Vacuum Tanks In Primer**

Starting at \$17,000

Includes Aluminum Side Panels and Hose Trays.  
Available in 1400 to 5500 Gallons

**5**  
YEAR  
WARRANTY



**Complete Kits**

Starting at \$24,000

Includes Aluminum Side Panels,  
Aluminum Hose Trays, Lights, Valves and Paint.  
Available in 1400 to 5500 Gallons

**A Simple Treatment Solution for Today's Wastewater Challenges**

The Eljen GSF System is an Advanced Treatment System that is easily installed and requires no intricate mechanical devices. It has zero biological start-up period and offers a dependable solution with greater flexibility for your wastewater needs.

- Cesspool replacement
- Waterfront properties
- Small lots
- Tough repair sites

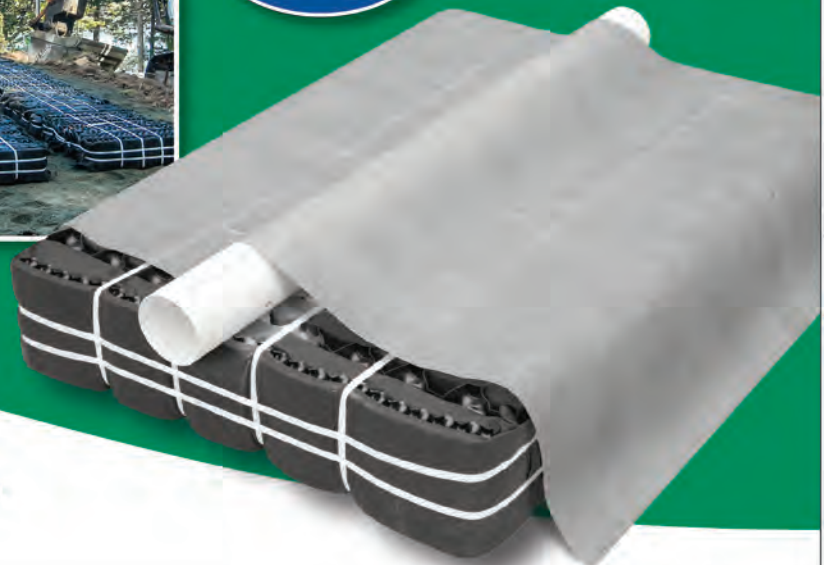

Innovative Environmental Products and Solutions Since 1970

www.eljen.com





# CUSTOM BUILT

We feel that every customer is unique and has distinctive requirements. Our commitment is to listen and work with you to build the finest vacuum system possible. Take advantage of our quality, experience, and after-the-sale support.



**CUSTOM BUILT. DRIVEN BY YOU.**





# 20

## Make it Better - Ken Wysocky

Luanne and Greg Howland bought a company with a long history of success, and then continued to add building blocks to profitability.

### 10 Between the Lines: Pumper-Nonprofit Partnership Tackles Rocky Mountain Waste Challenge

Grants ensure popular Colorado trailheads are stocked with clean restrooms for hikers, bikers and sightseers in a post-COVID world.  
- Jim Kneiszel

### 14 @pumper.com

Check out the latest online-only content at the Pumper website.

### 30 Building the Business: You've Decided to Dive Into Social Media Advertising. What Now?

Good planning and follow-through are required to take advantage of Facebook's huge audience and useful advertising analytics.  
- Jennie Lyon

### 36 Money Manager: Corporate Tax Analysis Is Helpful In a Challenging Economy

A qualified financial expert can wade into the intricacies of your pumping company to find ways to raise your bottom line.  
- Joan Koehne

### 40 Rules & Regs:

Massachusetts may require nitrogen technology for all of Cape Cod  
- David Steinkraus

### 44 Snapshot: Let's Teach How to Extend the Life of Onsite Systems

Tell homeowners about proper maintenance — and preach getting rid of garbage disposals.

### 50 Classy Truck of the Month

T.E. Price Septic & Excavating, Wayne, Ohio

### 54 Associations List

### 56 Septic System Answer Man: Monitoring and Sampling Are Always Good Ideas

Assuming a septic system is working properly could put human health and the environment at risk.

- Jim Anderson

### 58 Product Focus

Portable Sanitation  
- Craig Mandli

### 68 Product Focus/Case Study

Office Technology and Software  
- Craig Mandli

### 72 Product News/Spotlight:

Hydroexcavator promises full-size power in a mid-size package  
- Tim Dobbins

### 73 Industry News

## ON THE COVER:



Luanne and Greg Howland are owners of Apple Valley Pumping Service in East Wenatchee, Washington. They are shown with their fleet of vacuum trucks built out by Satellite Vacuum Trucks, Vacuum Sales Inc. and Erickson Tank & Pump. (Photo by Stephen Brashear)

## COMING IN NOVEMBER:

▶ **SNAPSHOT:** Visit a Missouri contractor

▶ **ANSWER MAN:** Are constructed wetlands viable?

# Pumper®

DEDICATED TO THE LIQUID WASTE INDUSTRY  
www.pumper.com

Published monthly by



COLE Publishing Inc.  
PO Box 220  
Three Lakes, WI 54562

© Copyright 2022 COLE Publishing Inc.  
No part may be reproduced without permission of the publisher.  
In U.S. or Canada call toll-free 800-257-7222.  
Email: info@pumper.com | Website: www.pumper.com

Office hours 7:30 a.m.-5:00 p.m. Central Time, Monday - Friday

**SUBSCRIPTION INFORMATION:** A one-year (12 issue) subscription to *Pumper* in the United States, Canada and Mexico is free to qualified subscribers. Subscriptions to all other foreign countries cost \$150 per year (\$290 for two years). Subscribers are guaranteed monthly delivery of the magazine. To subscribe please visit pumper.com or send company name, mailing address, phone number and check or money order (U.S. funds payable to COLE Publishing Inc.) to the address above. MasterCard, VISA, Discover and American Express are also accepted. Supply credit card information with your subscription order.

Our subscriber list is occasionally made available to carefully selected companies whose products or services may be of interest to you. Your privacy is important to us. If you prefer not to be a part of these lists, please contact Holly Gensler at holly.gensler@colepublishing.com

**CLASSIFIED ADVERTISING:** Submit classified ads online at www.pumper.com/order/classifieds. Minimum rate of \$25 for 20 words; \$1 per each additional word. Include a photo for an additional \$125. All classified advertising must be paid in advance. DEADLINE: Classified ads must be received by the tenth of the month for insertion in the next month's edition. PHONE-IN ADS ARE NOT ACCEPTED. Fax to 715-350-8456 only if charging to MasterCard, VISA, Discover or Amex. Include all credit card information and your phone number (with area code). Mail with check payable to COLE Publishing Inc. to the address above. CLASSIFIED ADVERTISING APPEARS NATIONWIDE AND ON THE INTERNET. Not responsible for errors beyond first insertion.



Jim Flory



Winnie May

**DISPLAY ADVERTISING:** Email Jim Flory at jim.flory@colepublishing.com or Winnie May at winnie.may@colepublishing.com or call 800-994-7990. Publisher reserves the right to reject advertising, which in its opinion is misleading, unfair or incompatible with the character of the publication.

**CONTROLLED CIRCULATION:** 20,500 per month. This figure includes all circulation regions (nationwide) and international distribution.

**REPRINTS AND BACK ISSUES:** Visit www.pumper.com/order/reprints for options and pricing. To order reprints, call Jeff Lane at 800-257-7222 or email jeff.lane@colepublishing.com. To order back issues, call Holly Gensler at 800-257-7222 or email holly.gensler@colepublishing.com.



▶ **GET THE TRUCK YOU NEED!**  
CUSTOM BUILT FOR YOU!



**New Hydraulic  
Hoist System**

**New Tanks  
from 1,800  
to 5,000 Gal.**

**100K Limited  
Engine Warranty**

**NVE 1600  
CFM Blower**

**New 20K  
Lift Axle**

**New Rims  
& Tires**

**New Custom  
Dupont Paint**

**Optional 20K  
Front Axle**



▶ **2010 Peterbilt 335**  
2,500 Gal., Hoist, CALL FOR PRICE!



▶ **2012 Peterbilt**  
Cummins ISX, 4,000 Gal., 15 Trucks Ready to Build! CALL FOR PRICE!

 **NEW & USED IN STOCK**  
 **MADE IN THE U.S.A.**

- 2 year/100K mile warranty on engine, transmission and rear end for Class 6 and Class 7 vehicles.
- 1 year/100K mile warranty included on engines for class 8 vehicles.





# ADVERTISER INDEX

A Restroom Trailer (ART Co.)73  
A.R. North America, Inc..... 55

**ABBOTT RUBBER**  
CONTRACT, INC.

Abbott Rubber Co., Inc.....47  
Allied Graphics, Inc.....72  
Ameri-Can Engineering.....71  
American Tank Company ....59



AQUA-Zyme Disposal Sys. .42

**arcan**

Arcan Enterprises, Inc.....71

**Armal**

Armal, Inc. ....63  
Bright Technologies .....47



Cam Spray.....55



Cape Cod Biochemical Co. .39  
Century Chemical Corp. ....61

*Comforts of Home*

Comforts of Home Services... 16  
COXREELS.....16  
Crane Pumps & Systems..... 33



CRO Software Solutions..... 66



Crust Busters .....49

**DAVIDSON TANK**

Davidson Tank .....53



Deal Assoc.....49

DRE Custom Trailers.....38

Eljen Corporation.....4



Elmira Machine Industries/  
Wallenstein Vacuum ..... 15



Engine & Accessory, Inc.....57  
F.M. Manufacturing, Inc. ....51



FlowMark Vacuum Trucks ...18

FMC Advisors .....34



Fruitland Manufacturing.....41



GapVax, Inc.....13



Hi-Vac Corporation .....29



House of Imports .....7

Howden .....59



Imperial Industries, Inc. ....83



In the Round Dewatering....28



Integrity Tank Sales & Svc...51



ITI Trailers & Truck Bodies ..31

Jack Doheny Company .....63



Jet, Inc.....71

Johnny's Choice .....8



KeeVac Industries, Inc.....37

Key Commercial Corp. ....53

**LANE'S VACUUM TANK, INC.**

Lane's Vacuum Tank, Inc..... 16

Lang Specialty Trailers .....61



Marsh Industrial .....48



McKee Technologies -  
Explorer Trailers .....15

Mid-State Truck Service, Inc.69



Milwaukee Rubber Products.18

MTH Pumps.....69

MyTana LLC .....45

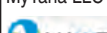

N.A.W.T.....52

National TruckCenter

National Truck Center .....9



National Vacuum Equipment .3

Norweco, Inc.....67

NuConcepts

NuConcepts.....42

OI Restrooms .....48



Orengo Systems, Inc. ....65

Park Process .....59



Pik Rite, Inc. ....47



PolyJohn.....2



PortaLogix .....53



Pressure Lift Corp.....52

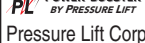

Presvac Systems.....84



ProgressTank.....34



Ritam Technologies LLC.....48



Robinson Vacuum Tanks .....42

ROEDA.....38



RootX.....73



Roth North America .....72



Satellite Industries .....35

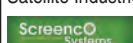

ScreenCO Systems, LLC ....70

ServiceCore.....61



Sonetics.....43



T&T Tools, Inc.....12



T.S.F. Company, Inc.....17

Tank Track LLC.....28



Tank World Corp.....32



TankTec .....12

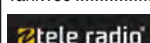

Tele Radio America.....69



Transport Truck Sales, Inc...66



Tranway Systems, Inc.....5

Truck Country .....63



TSI Tank Services, Inc.....38



TUF-TITE, Inc.....25, 52

UDOR U.S.A.....49



US Tanks Industry .....4



Vac-Con, Inc.....23



VacutruX Limited .....15



Vacuum Sales, Inc.....50



VARCO.....27



Walex Products Company ..19



Westmoor Ltd. ....28

WWETT Show .....82

Classifieds.....76-81

Marketplace.....74-75

## REGIONAL ADVERTISERS

### Midwest Supplement

(after page 50)



Advance Pump & Equipment. 4

LINCOLN CENTER

Lincoln Center Manufacturing/  
Marengo Fabricated Steel . 1



Navitas Credit Corp. ....4

R.A. Ross & Associates NE... 3

### Eastern Supplement

(after page 50)



Advance Pump & Equipment...4

LINCOLN CENTER

Lincoln Center Manufacturing/  
Marengo Fabricated Steel..1



Navitas Credit Corp.....4

R.A. Ross & Associates NE....3



Vacuum Sales, Inc.....2

## EXPERIENCE THE JOHNNY'S CHOICE FRAGRANCE ADVANTAGE



Bubble gum



Cherry



Fresh air



Grape



Hawaiian breeze



Mulberry

# johnny's Choice

"BLUE like you NEVER KNEW!"

## PORTABLE TOILET DEODORIZERS



www.johnnyschoice.com | 1 888 729-6478

# MORE?!

More Stories at Pumper.com/featured

## Pumper

See what's not in print!



# National Truck Center

EST. 1981

954-410-6553

786-367-4961

www.NationalTruckCenter.com

3001 EAST 11th AVENUE | HIALEAH, FL 33013

## NEW TRUCKS



### 2022 International CV 515

Duramax 6.6L (350 HP), Automatic,  
New 1400 Gallon Tank, New Masport  
HXL75 Vacuum Pump (230 CFM)

\$111,000



### 2024 Mack MD7

Mack MP8 (350 HP), Allison Automatic,  
New 2500 Gallon Tank, New Jurop PN-84  
Vacuum Pump (317 CFM)

\$134,000



### 2024 Mack MD7

Mack MP8 (350 HP), Allison Automatic,  
New 2500 Gallon Tank, New Jurop PN-84  
Vacuum Pump (317 CFM)

\$134,000



### 2023 Western Star 47X

Cummins L9 (370 HP), Allison Automatic,  
New 4000 Gallon Tank, New Jurop LC-420  
Vacuum Pump (423 CFM)

\$183,000



### 2023 Western Star 47X

Cummins ISX (450 HP), Allison Automatic,  
New 4000 Gallon Tank, New Jurop LC-420  
Vacuum Pump (423 CFM)

\$196,000



### 2024 Mack Granite

Mack MP8 (450 HP), Allison Automatic,  
New 4000 Gallon Tank, New Jurop LC-420  
Vacuum Pump (423 CFM)

\$211,000



### 2024 Mack Granite

Mack MP8 (450 HP), Allison Automatic,  
New 4000 Gallon Tank, New Jurop LC-420  
Vacuum Pump (423 CFM)

\$211,000



### 2023 Western Star 4700 Legacy

Cummins ISX (450 HP), Allison Automatic,  
New 5000 Gallon Tank, New Jurop LC-420  
Vacuum Pump (423 CFM)

\$212,000

## PRE-OWNED TRUCKS READY TO GO



### 2016 International 4300

DT-466 (245 HP), Allison Automatic, 177K Miles,  
New 2000 Gallon Tank, New Masport  
HXL75 Plug and Play System (230 CFM)

\$104,000

LOW MILES



### 2012 International 4300

DT-466 (245 HP), Allison Automatic,  
43K Miles, New 2000 Gallon Tank,  
New Masport HXL75 Vacuum Pump (230 CFM)

\$104,000



### 2015 International 4300

DT-466 (245 HP), Allison Automatic, 289K Miles,  
New 2500 Gallon Tank,  
New Jurop PN-84 Vacuum Pump (317 CFM)

\$93,000



### 2011 International 4400

DT-466 (310 HP), Allison Automatic, 183K Miles,  
New 3600 Gallon Tank,  
New Jurop R-260 Vacuum Pump (360 CFM)

\$93,000



### 2011 International 4400

DT-466 (310 HP), Allison Automatic, 121K Miles,  
New 3600 Gallon Tank,  
New Jurop R-260 Vacuum Pump (360 CFM)

\$96,000



### 2014 Mack Vision

MP7 (425 HP) 10 Speed Manual, 201K Miles,  
New 4000 Gallon Tank, New Jurop LC-420  
Vacuum Pump (423 CFM)

\$129,000



### 2015 Freightliner M2

Cummins ISL (380 HP), 10 Speed Manual,  
226K Miles, New 4000 Gallon Tank,  
New Jurop LC-420 Vacuum Pump (423 CFM)

\$140,000



### 2015 Freightliner Cascadia

Detroit DD13 (450 HP), 10 Speed Manual,  
374K Miles, New 5000 Gallon Tank,  
New Jurop LC-420 Vacuum Pump (423 CFM)

\$142,000

TRANSPORTATION AVAILABLE NATIONWIDE



Sold exclusively at  
National Truck Center







Contact Jim with your comments, questions and opinions at [editor@pumper.com](mailto:editor@pumper.com).

**Jim Kneiszel**  
Editor

# Pumper-Nonprofit Partnership Tackles Rocky Mountain Waste Challenge

Grants ensure popular Colorado trailheads are stocked with clean restrooms for hikers, bikers and sightseers in a post-COVID world

By Jim Kneiszel

Since COVID-19 struck a few years ago, it seems like pumpers everywhere have taken the definition of “busy” to a new level. More folks staying home means more pressure on septic systems, and that translates to more emergency and routine maintenance calls for your service company.

Many of you also offer portable sanitation services, and the story there has been much the same. From the start, experts encouraged people to gather outdoors and take part in safer social situations such as picnics, hiking, biking and camping. And when COVID concerns started to ease, our favorite large special events returned with a vengeance.

What side of the wastewater industry is busier? We won’t speculate about that. But on the restroom side, the critical role portable sanitation plays in protecting the environment and our favorite gathering spots has become crystal clear.

One great example is playing out in the Rocky Mountains of Colorado, a mile-high mecca for outdoor enthusiasts. Chaffee County, a few hours from Denver and surrounded by 14,000-foot peaks, has become overrun by tourists since the start of COVID, and all of those people need places to relieve themselves. Hiking trails and dispersed campsites were receiving so much waste there was no more room for visitors to bury it. The waste piling up was causing a nuisance and public health danger.

## RESTROOM GRANTS

The Chaffee Recreation Council, through its Keep it Clean initiative, stepped in and awarded grants to provide portable restrooms at 11 popular trailheads. The council gave Chaffee Common Ground grants to the Greater Arkansas River Nature Association and the Salida Mountain Trails group to provide the restrooms. Mr. Pots of Woodland Park, Colorado, placed 22 units at the start of the trails in June, and will continue to service them weekly throughout the six-month tourist season. The grants totaling \$53,000 will cover the cost of the units and service for three years.

Five Arkansas Headwaters Recreation Area trails are the Tunnel View, Riverside, Elephant Rock, Rapid No. 4 and Stone Cabin. U.S. Forest Service locations are at the Browns Creek/Raspberry Gulch Recreation Area, South Cottonwood Creek, North Cottonwood Creek and Mushroom Gulch in the Fourmile Recreation Management Area. Salida Trail System locations are at Beasway as well as CR 108, CR 110 and Spiral Drive.

“From a tourism perspective, if people show up to a dirty, stinky campsite, it’s not going to be a good experience for them. We want to have the infrastructure to serve our tourists in a good and sustainable way. Port-a-potties are such an obvious solution.”

– Kim Marquis

Until being slammed by COVID, visitors to popular Western recreational lands typically relied on “leave no trace” rules for going to the bathroom in the wilderness. Those include either hand-digging what is called a cat hole and covering up the waste or using a waste alleviation and gelling bag to carry out waste to dispose of in the trash once they reach civilization. Those solutions just weren’t satisfactory with the higher volume of visitors, according to Kim Marquis, outreach coordinator for Envision Chaffee County, which administered the new grants.

“There was an exponential increase in use of public lands. A lot of people bought tents and came with their bikes to try and enjoy the outdoors. It was recommended that people do things outdoors during the pandemic and that was partaken by lots of folks,” Marquis told me.

## GIVING THANKS

Marquis said public land agencies have reported a recent 50% increase in tourist traffic, and that created a need for more wastewater facilities. Pit toilets or other more permanent solutions cost a lot of money and take time to gain approval and get built. That’s where portable restrooms provide a great service, she said. The restrooms can be placed quickly and cost-effectively, and they can be easily moved as needs change.

So far, the portable restrooms have been a big hit, Marquis explained.

“People are very thankful they are there. Chaffee County has hundreds of thousands of acres of public land and it’s not all accessible with portable





◀ Lia Hovezak, a recreation ranger with the Arkansas Headwaters Recreation Area, is shown with two restrooms from Mr. Pots that are stationed on a trailhead in Chaffee County. The restrooms are wrapped with messages about fire safety and protecting wilderness areas. She is holding a waste alleviation and gelling bag hikers use to pack out their waste.

✔ One of the stickers is shown on a restroom side panel. The contractor, Mr. Pots, requested the use of adhesives that make the stickers easy to remove.



toilets, but this is certainly much better than what we had before,” Marquis said. “Managing human waste was one of the major things we had to address and people are pleased. I hear a lot of ‘thank-you’s.”

Popular campground areas were one problem. With repeated use and running out of areas to dig cat holes and dump waste, the end of summer could be an unsanitary mess at dispersed campgrounds that don’t have permanent facilities. Besides the trailheads, Marquis said there are many additional areas throughout the West where portable restrooms could be a positive solution to a waste problem.

“From a tourism perspective, if people show up to a dirty, stinky campsite, it’s not going to be a good experience for them. We want to have the infrastructure to serve our tourists in a good and sustainable way. Port-a-potties are such an obvious solution,” Marquis said. “We don’t know if using port-a-potties is the answer forever, but it’s a stopgap measure until we get more permanent toilets.”

Beyond the natural areas, Marquis said the portable restrooms help ease pressure on public and business bathrooms in the towns of Chaffee County. Without facilities in the recreational areas, visitors come down to the villages to use the bathrooms and dump their trash, overwhelming park workers and small businesses. Portable sanitation providers could target this potential customer base to provide units in more urban settings.

### HELPFUL STICKERS

An interesting twist that has gained positive attention is the Chaffee County Visitors Bureau working with the GARNA and Mr. Pots to create and install informative stickers or wraps on the restrooms to help the public understand the “leave no trace” message and to promote fire safety in the tinder box that is the American West.

Marquis said the wraps were a “genius” idea.

“Any way to share education and help people learn so the people who come behind them can enjoy (nature) as much as they did is a great idea,” she said. Marquis envisions restroom users waiting in line and focusing on these important messages, such as watching for windy conditions that make fires more dangerous and picking up after pets.

Mr. Pots drivers are servicing the 22 units with included hand sanitizers weekly, but not all on the same route. Sales Manager David Royar said

common sense dictates when and where the units are serviced in the rugged, mountainous region. “There’s one site where our drivers don’t like to go up to, with rough roads,” Royar said. The service truck has to go slow over the gravel roads to reach remote locations, but the company is happy to help the cause.

“They’re trying to divert feces from being out in the woods. They’re for a good purpose,” he said.

Royar explained the company was happy to include the promotional stickers on three sides of the units and they will place the same units on these sites for the duration of the contract. His only request was that organizers choose an adhesive that will allow the stickers to be easily removed once the units are no longer needed at the trailheads.

There has been one issue with the restroom service. Royar said hikers and campers have been depositing bagged human waste from the campgrounds and assorted trash in the units, which makes the services more time consuming. However, GARNA has installed trail cams at the restroom sites and tracks down offenders to ask them to dump waste from the plastic bags and into the holding tanks, he said.

### RESTROOMS NEEDED

It’s encouraging to see partnerships like this one where wastewater professionals are working with nonprofit groups to provide a valuable service to ensure a cleaner environment and the public’s enjoyment of the vast American wilderness. The COVID pandemic sent millions of people out to explore the most beautiful places in this country. It has also highlighted the importance of spreading effective portable sanitation to these areas far and wide.

As an industry we have learned a lot from the pandemic, not the least of which is that the public will demand restrooms and clean service in many more locations and situations. It’s been a tumultuous period in history, but a time that confirmed over and over again that you provide an essential service to grateful users. **P**



1.888.428.6422

SNELSON@TANKTEC.BIZ

# TankTec

Tank Technologies & Supply Co, LLC

WWW.TANKTEC.BIZ

300 to 6000 Gallons  
Aluminum or Stainless

FORD 1500 GALLON



INTERNATIONAL  
4000 GALLON

2000 GALLON  
PORTABLE  
RESTROOM



## SLIDE IN TANKS

### Standard Features:

- Aluminum construction
- 25' vacuum hose with valve and wand
- Honda engine driven vacuum pump
- 12v water pump

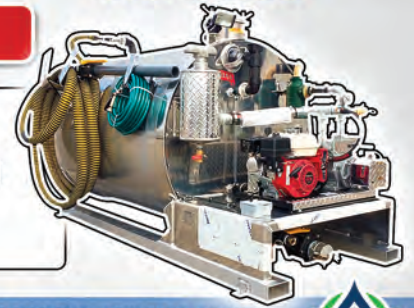

# TankTec

FACTORY BUILT TRUCKS, BUILT-TO-ORDER  
IN-STOCK, FINANCING & LEASE OPTIONS



# T&T Tools, Inc.

Fax: 800.521.3260

Email: sales@mightyprobe.com

# 800.521.6893

www.MightyProbe.com



Call for a FREE Catalog

Call for a FREE Catalog

## HOOKS...

- > Several different styles of heat-treated hooks are available
- > Top Poppers are great to open manhole covers
- > The Handy Hooks allow two handed use

## PROBES...

- > Insulated, standard, and specialty soil probes
- > Metal shaft sizes: 3/8" round, 3/8" hex, or 7/16" hex
- > Replaceable tips are threaded on and hardened
- > A "slide" allows the handle to pound the shaft into the ground



# ESSENTIAL EQUIPMENT FOR ESSENTIAL WORKERS

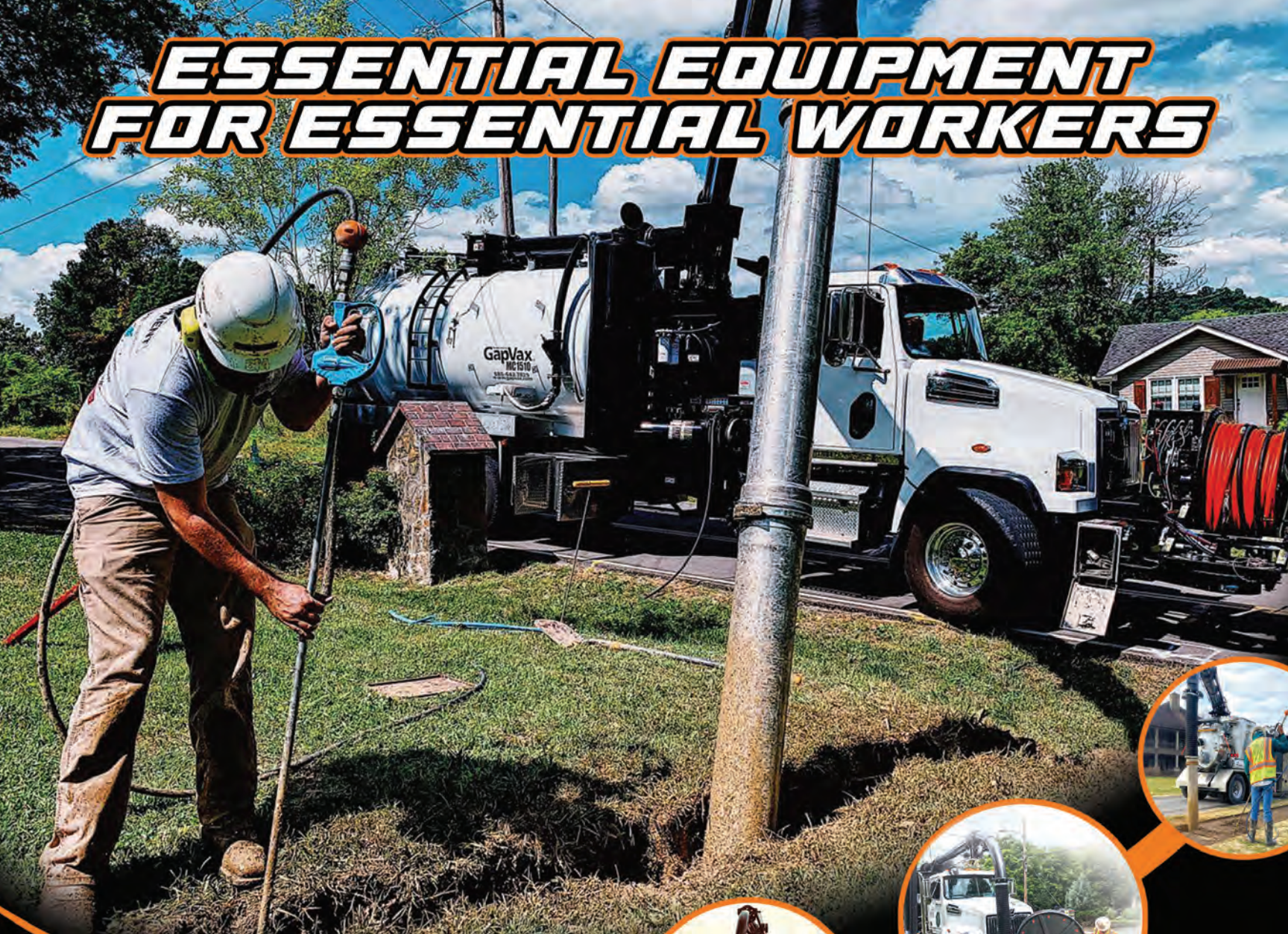

HAVE YOU CHECKED OUT  
OUR NEW G7 JETTER TRAILER?

For the #1 Choice Manufacturer of Custom-Built industrial and municipal vacuum equipment, GapVax has what you need! Air Movers, Jetters, Hydro Vacs, Combo JetVac, Recycle JetVacs, Skid-mounted vac units, Parts and accessories & more! Check out [gapvax.com](http://gapvax.com) for more information and keep up to date with us on social media!



  
GAPVAX.COM

281-884-8658  
LA PORTE, TX

888-442-7829  
JOHNSTOWN, PA



# @ Pumper.com

Visit the site daily for new, exclusive content. Read our blogs, find resources and get the most out of Pumper magazine.



## FLEET PLANNING STRATEGIES

### 5 key components

There are tools and technology available that make developing and implementing an effective fleet maintenance plan easier than ever before. Creating a plan will help save your company plenty of time, frustration and money. In this online article, learn the five questions you should ask yourself when developing a fleet maintenance strategy.

[pumper.com/featured](https://pumper.com/featured)



## GRAVITY TRENCHES

### how long should they be?

Many regulations across the U.S. and Canada limit gravity trench lengths to 100 feet. Is this length justified in science or practices? Find out the answer in this online article by Sara Heger, researcher and educator in the Onsite Sewage Treatment Program at the University of Minnesota.

[pumper.com/featured](https://pumper.com/featured)

“Lawsuits can be a drag, but they don’t have to prevent you from providing leadership to your team, and real value to your customers.”

– Apply a Strategic Approach If Your Business Is Sued  
- [pumper.com/featured](https://pumper.com/featured)



## ELECTRIC EQUIPMENT

### the future of construction

With diesel prices over \$5 per gallon in the United States, you might be wondering if an electric-powered machine could reduce your operating costs. Or you may want to reduce your carbon footprint. Whatever your reasons, your time will be well spent, as electric machines promise to be a big part of the future of construction.

[pumper.com/featured](https://pumper.com/featured)

## ERGONOMIC TOOLS

### features to prioritize

As ergonomic tool design becomes the standard, understanding basic ergonomic features to look for when making a purchase will help ensure you are investing in the best equipment for your team. Size and weight are among the key characteristics to consider when searching for tools that will minimize user strain and fatigue.

[pumper.com/featured](https://pumper.com/featured)



## CONNECT WITH US

### emails and alerts

Visit [Pumper.com](https://Pumper.com) and sign up for newsletters and alerts. Get exclusive content delivered right to your inbox, and stay in the loop on topics important to you!

### want more?

Find us on Facebook at [facebook.com/PumperMag](https://facebook.com/PumperMag) or Twitter at [twitter.com/PumperMag](https://twitter.com/PumperMag)



# LIQUID COOLED VACUUM PUMPS (220-800 CFM)

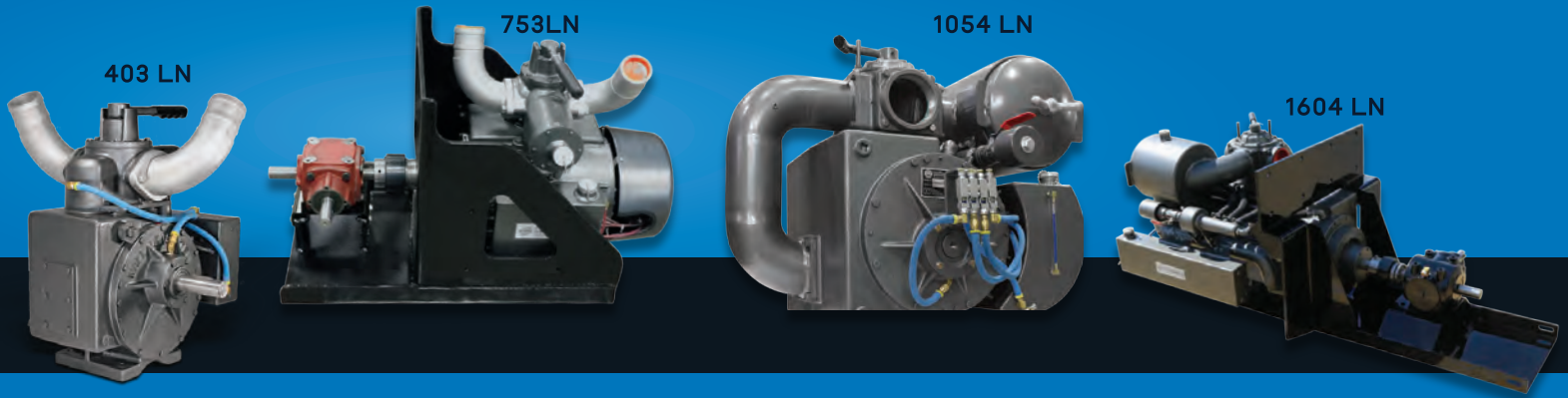

**Wallenstein**  
vacuum pumps

Manufactured by  
**EM** elmira  
machine  
industries inc.

**wally**  
vacuum pumps  
WALLENSTEIN.COM

1.800.801.6663



**vacutrux**

**SEPTIC TRUX**

from 1800USG to 5600USG,  
Multi-axle configurations to  
meet state or provincial regulations

VACUTRUX.COM



1.800.305.4305



**EXPLORER**



MANUFACTURED BY  
**McKEE**  
TECHNOLOGIES INC.

**TRANSPORTER**  
TRAILERS



ALBERTA	ONTARIO	QUEBEC	ARIZONA	CALIFORNIA	COLORADO	FLORIDA	TEXAS
Tel: 886-587-7262	Tel: 519-669-5720	Tel: 819-820-7659	Tel: 480-208-6997	Tel: 530-832-0370	Tel: 303-526-5370	Tel: 321-830-2239	Tel: 817-453-7401

1.866.457.5425

MCKEETECHNOLOGIES.COM





# LANE'S VACUUM TANK, INC.

**BUILT BY  
FOR PUMPER  
PUMPER**

## Aluminum Tanks

All sizes available

**Call for Price**

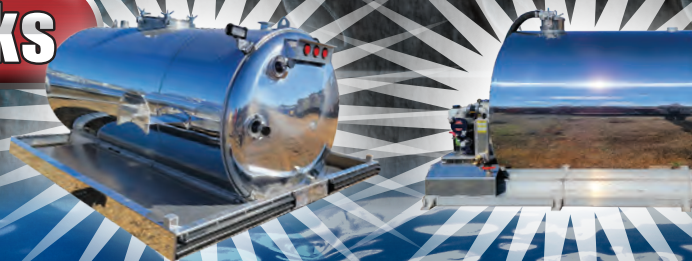

## Slide-Ins

All sizes available

**Call for Price**

### Dodge, International or Ford



950/300  
Aluminum Tank;  
Gas or Diesel;  
4x2 or 4x4

**Call for Price & Availability**

### Toilet Transport Trailers



**13" Tires • 25" High**

Spare Tire. Adjustable Hitch.  
3500 Pound Axles with Brakes.  
1 Beam Fold Up On Rear  
for Handicap Units

Used trailers also for sale

- 6 Hauler
- 10 Hauler
- 12 Hauler
- 14 Hauler
- 16 Hauler
- 18 Hauler
- 20 Hauler

SLIDE-IN UNITS & USED TRUCKS AVAILABLE / MASPORT, JUROP & CONDÉ VACUUM PUMPS

All Brands and Sizes of Aluminum & Steel Tanks and Trucks are Available

800.592.3308 • 270.527.9945 RODNEY LANE'S CELL 270.832.3793 WWW.LANESMOBILEJOHN.COM

## THE MOST LAYOUTS AVAILABLE FOR HANDICAP ACCESSIBLE TRAILERS



Proudly Made  
Since 2003

**Comforts of Home**  
Services, Inc.  
BATHROOM • SHOWER • SPECIALTY TRAILERS



63-07F-0236V

See our website for floor plans and options.

info@cohsi.com • 630.906.8002 • www.cohsi.com

## TACKLE THE TOUGHEST JOBS

WITH QUALITY YOU CAN TRUST!



**COXREELS®**

**PRO GRADE  
HOSE, CORD,  
& CABLE REELS**

- ✓ Efficient Septic & Sewer Clean-Up Operations
- ✓ Enhance Worksite Safety
- ✓ Corrosion Resistant, Powder-Coat or Stainless Steel Finishes



PRESSURE WASH | FLUID TRANSFER | VACUUM | AND MORE

LEARN MORE:

TOLL FREE | 800.269.7335

FOLLOW US:

WWW.COXREELS.COM







# TUFF-JON

Portable Toilets | Holding Tanks | Hand Wash Units | Accessories



TJ Kids



TJ Shorty



Tuff-Jon III



Tuff-Jon



100 Gallon Fresh Water Supply Tank



60 Gallon Rinse Tank



Containment Tray



Sink Lifting Bracket

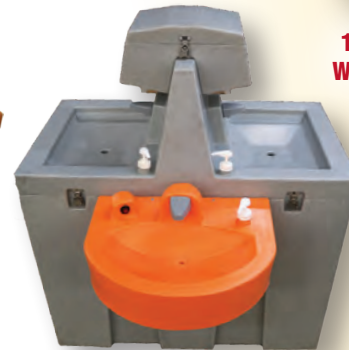

90 Gallon Free-Standing Sink with Optional Handicap Accessible Sink (45 gallons fresh water)



TJ Handy Stand Waterless Gel Touch Dispensers

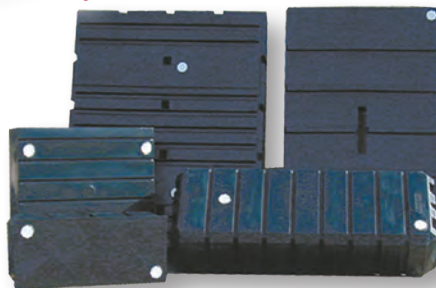

- Tank sizes 60, 105, 225, 300 and 440 gallons.
- Standard holes are 2 - 3" holes with plugs
- Can customize holes to match your specs



Interior View of Deluxe TJ-III

TJ Junior Single Free Standing Sink (16 gallons fresh water)



- Lifting Bracket Assembly
- Sky Heater
- Corner Shelf
- Towel Dispenser
- Hand Washer Available For Both Styles of Tuff-Jon



**The TSF Company Inc.** Toll Free: 1-800-843-9286 | 812-985-2630 | Fax: 812-985-3671  
 2930 S St. Phillips Rd. | Evansville, IN 47712 Email: aschenk@tuff-jon.com | Website: www.tuff-jon.com





VISIT: [FLOWMARK.COM/USA](http://FLOWMARK.COM/USA)

**VACUUM TRUCKS**  
1,000 - 5,500 GALLONS



**ORDER NOW TO RESERVE**  
**4TH QUARTER BUILD SLOTS**  
TO QUALIFY FOR  
**SECTION 179 TAX DEDUCTIONS!**



**RESTROOM TRUCKS**  
800 - 2,500 GALLONS

☎ 833.653.8100    ✉ [sales@flowmark.com](mailto:sales@flowmark.com)    🌐 [www.flowmark.com](http://www.flowmark.com)

**HOSE & EQUIPMENT SPECIALISTS**

**Kanaflex**  
Hose Distributor

Kanaflex FLEXAUST PLASTIFLEX tigerflex Juroop E-T-N Parker BW Technologies NVE

Fast Shipping!

[www.MilwaukeeRubber.com](http://www.MilwaukeeRubber.com) 800-325-3730



# Is your holding tank haunted by waste build-up?

October is a spooky month, and residual holding tank build-up can increase the fear factor—unless you have Commando.



Even though you use deodorizer, your trailer's holding tank needs a deep cleaning after the busy summer event season. **Commando Black Holding Tank Cleaner** is a powerful enzyme-based drop-in that eliminates residual waste and paper build-up overnight!





► **Pumper PROFILE**

✔ Luanne and Greg Howland are shown with their fleet of vacuum trucks built out by Satellite Vacuum Trucks, Vacuum Sales Inc. and Erickson Tank & Pump. The fleet runs with Masport and National Vacuum Equipment pumps. (Photos by Stephen Brashear)



**Make it  
BETTER**



Luanne and Greg Howland bought a company with a long history of success, and then continued to add building blocks to profitability

By Ken Wysocky



## Apple Valley Pumping Service

East Wenatchee, Washington

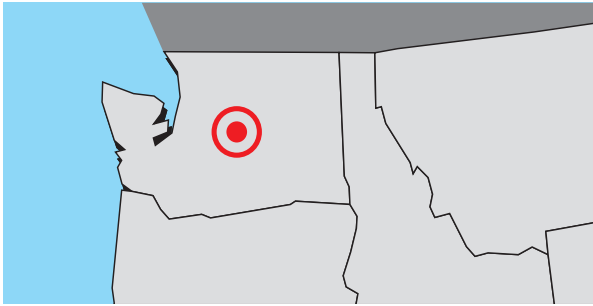

**OWNERS:** Luanne and Greg Howland

**FOUNDED:** 1979

**EMPLOYEES:** 18

**SERVICE AREA:** 60-mile radius around East Wenatchee

**SERVICES:** Pumping septic tanks, portable restroom rentals

**WEBSITE:** [www.applevalleypumpingsvc.com](http://www.applevalleypumpingsvc.com)

**W**hen Luanne and Greg Howland bought Apple Valley Pumping in 2018, they acquired a well-established business that was founded decades ago in 1979, offering customers both septic and grease tank pumping service and portable restroom rentals.

As such, it would've been easy to maintain the status quo. But that's just not how the dynamic and industrious couple rolls.

"That would never do," says Luanne. "Greg and I never set any particular goals for number of customers or revenue, but I don't think we're different from any other business — we want every job. We're not content to stand pat.

"We bought this business for its potential."

So far, so good. Annual revenue for the business — based in East Wenatchee in central Washington, about 150 miles east of Seattle — has jumped about 30% since 2019, their first full year owning the business. Its fleet of septic pumping and restroom service vehicles expanded by six, including two septic trucks and two restroom service trucks. And its workforce grew from 13 to 18.

Key factors in the company's growth arc? Diverse services; investments in productivity-enhancing technology; land application of waste, which reduced disposal and transportation-related costs; a great team of employees; strong work ethic; and a strong emphasis on customer service.

"We bought a company that was very well-established, so we had a good foundation — we weren't starting from zero," she notes. "But we re-emphasized timely customer service. That's what has taken us to the next level in the industry."

**“ WE’LL TAKE WHATEVER GROWTH WE CAN GET. WE HAVE ENOUGH EMPLOYEES TO ABSORB FUTURE GROWTH FOR THE TIME BEING. ... IF WE FIND GOOD EMPLOYEES, WE’LL HIRE THEM AND FIND WORK FOR THEM. ”**

**LUANNE HOWLAND**

### WORKING TOGETHER

It's also difficult to ignore the power of the couple's great working relationship. Greg handles most corporate-related responsibilities, pumps septic tanks when needed and also runs a plumbing business, while Luanne schedules commercial septic jobs and restroom rentals, manages vehicle maintenance and handles other office responsibilities.

"Luanne is fantastic," says Greg. "Her organizational skills are 10 times better than mine. And she's not afraid to dig in. She has a commercial driver's license and can pull and back up a trailer, pump a tank and change out a toilet. She can do anything."

"It's not always easy," Luanne says of the workplace husband-and-wife dynamic. "But we work super well together. Greg is a rock — he's very calm, which is invaluable when dealing with so many customers. He never flies off the handle.

"And I'd say his loyalty to the employees who stayed with the business after we bought it is amazing."

Employees also appreciate the fact that the Howlands regularly assist out in the field.

"I believe it increases the morale of employees when you work alongside them," Greg explains. "We just hired a driver and he told me he couldn't believe I work out in the field with him. But I love working and believe it's important to lead by example."

### ON THE JOB

No one can accuse the Howlands of being slackers. Greg, 59, started working with his father, Vern Howland, a plumber in Jerome, Idaho, when he was 10 years old.

After working in retail businesses, Greg actually was hired at Apple Valley (then called Apple Valley Pumping Services) in 1986. After four years, he left and started a plumbing business that he still owns. When the former owners of Apple Valley, Steve and Susan Gregg, decided to retire, they called their former employee and worked out a deal to sell the company.



**◀** Luanne Howland, left, Alex Bravo, center, and Mike Kennedy pull a filter to be cleaned during a septic service call in Crescent Bar, Washington.





“GREG AND I NEVER SET ANY PARTICULAR GOALS FOR NUMBER OF CUSTOMERS OR REVENUE, BUT I DON'T THINK WE'RE DIFFERENT FROM ANY OTHER BUSINESS — WE WANT EVERY JOB. WE'RE NOT CONTENT TO STAND PAT.”

**LUANNE HOWLAND**

“I enjoyed the work before when I worked there in the 1980s,” Greg says, explaining his interest in buying Apple Valley. “I knew there was potential to increase the business and make it better than it was.”

“But the thing that really triggered it was a septic emergency we had at some rental properties we own,” he adds. “We were told we'd have to wait two weeks. That told me there was an opportunity out there to provide better service.”

On the other hand, Luanne, 45, ran a hay delivery business for livestock and horses for 20 years. At the same time, she also worked a swing shift at a U.S. Postal Service mail-sorting facility in Wenatchee. Luanne left the postal job after they bought the company.

### TRACKING PROGRAM

At first, the couple avoided major changes because they didn't want to make it uncomfortable for employees who stayed on board after the acquisition.

But they did invest in a Verizon Fleetmatics Reveal GPS tracking system



► Greg Howland climbs down from a 4,700-gallon pup trailer used to transfer waste from big jobs like cleaning septic tanks at fruit-packing sheds or highway rest areas.

◀ Howland, left, handles the wand during a pumpout while a technician loosens sludge in the septic tank.

► After pumping, Howland closes the valve on his service truck built out by Erickson Tank & Pump and carrying a Masport pump.



(now known as Verizon Connect Reveal & Work) that also offers business management capabilities such as dispatching, job-scheduling and vehicle-maintenance tracking, Greg says.

The service costs about \$30 per month per vehicle for a total payment of about \$660 a month. Greg says the system easily pays for itself every month by boosting routing efficiency alone.

“We didn't tell drivers about the system for about a month,” he says. “Then one day we brought in a 70-inch monitor and hung it on a wall in the office. It displays a giant map that shows the location of every truck. There was some pushback from some people, but for the most part, nobody cared.”

The system also sends notifications when technicians drive aggressively. It also can provide proof of service if customers call and claim that their tank wasn't pumped or their restrooms weren't cleaned, Greg notes.

### RESTROOM SERVICE

In a typical year, restroom rentals and service generate about 55% of annual revenue, with septic tank and grease trap pumping kicking in the balance. For about half of a year, monthly rentals provide most of the restroom revenue; the other half of the year, monthly rentals drop to about 60% of the revenue, with special-event rentals contributing the rest, Greg says.

*(continued)*





## IT'S TIME TO GO PRO

The patent-pending PRO Reel from Vac-Con is the most versatile, operator-focused hose reel available in the industry.

With a working area of over 69.6 square feet and 16 feet of traversing motion across the front of the unit, the PRO Reel offers the most hose reel coverage in the market. Combined with our in-cab manhole placement camera system, the PRO Reel can reduce your setup time by 50%.

Learn more at [www.vac-con.com / pro](http://www.vac-con.com/pro)





◀ Mike Kennedy pulls hose on a pumping job. His truck was built out by Satellite Vacuum Trucks and runs a Masport pump.

“ WE BROUGHT IN A 70-INCH MONITOR AND HUNG IT ON A WALL IN THE OFFICE. IT DISPLAYS A GIANT MAP THAT SHOWS THE LOCATION OF EVERY TRUCK. THERE WAS SOME PUSHBACK FROM SOME PEOPLE, BUT FOR THE MOST PART, NOBODY CARED. ”

**GREG HOWLAND**

From 2019 to 2021, restroom rental revenue jumped 31%, an increase he attributes to marketing, consistent service and prompt deliveries.

To service restrooms, the company relies on 11 restroom trucks, all built by Satellite Vacuum Trucks on Dodge 5500 chassis. Most of them carry 600-gallon waste/300-gallon freshwater steel tanks with Conde vacuum pumps, by Westmoor Ltd.

The company also owns roughly 2,500 standard restrooms, around 150 hand-wash stations and about 30 hand sanitizer stations, all from Satellite Industries. For special events, the company invested in a NuConcepts luxury restroom trailer.

To serve agricultural customers, the company also relies on small trailers, fabricated by a local company, that hold single restrooms.

## SEPTIC FLEET

On the septic services side, the company runs two 2007 Peterbilts from Vacuum Sales Inc. with 3,600-gallon aluminum tanks; a 2015 Kenworth from Satellite with a 3,600-gallon aluminum tank; a 2021 Volvo VHD from Satellite, featuring a 4,000-gallon aluminum tank; a 1990 Kenworth rigged out by Erickson Tank & Pump with a 3,600-gallon steel tank; and a 2020 International built by Erickson with a 3,700-gallon aluminum tank. All the trucks feature Masport pumps except for the 2015 Kenworth and the Volvo, which have pumps from National Vacuum Equipment.

Apple Valley also owns a pup trailer with a 4,700-gallon steel tank. It's towed by the 2020 International truck and used primarily for big jobs like cleaning septic tanks at fruit-packing sheds or highway rest areas.

“With fuel costs so high, it's great when you can carry about a double load and still use roughly the same amount of fuel,” Greg says. “We're thinking about getting a second one because they're so versatile — we sometimes off-load waste from another truck into the pup-trailer tank, for example, and save a disposal trip.”

Luanne says the company benefits from offering a broad menu of services. And cross-marketing opportunities abound; as an example, Luanne says that when she delivers restrooms to a wedding where the facilities have a kitchen, she mentions that the company also cleans grease traps.

“Or maybe a facility doesn't have a kitchen, but it holds one or two big special events a year,” she adds. “Then I can mention we also do septic pumping.”

## LAND APPLICATION

Apple Valley also relies on a 6x6 International truck, which was an old military vehicle, used to land-apply waste on 1,000 acres of farmland the couple owns. The truck features a 4,000-gallon steel tank built by

*(continued)*



# 24" HEAVY DUTY MULTI-PURPOSE FLAT RISER LID

**Fits most commercially available:**

- Risers
- IPEX PVC Ribbed Pipe
- Corrugated Pipe

**LID MAY BE USED WITH OR WITHOUT CONCRETE CENTER**

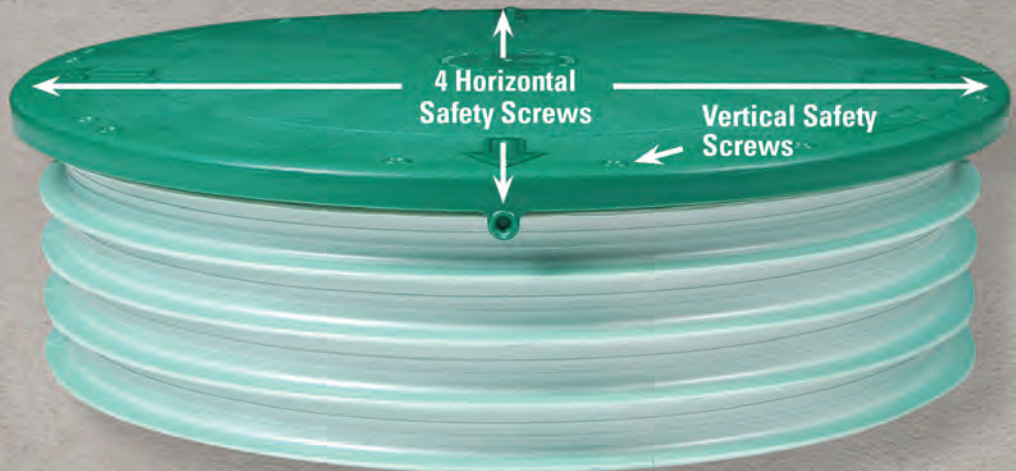

Secured by 6 Vertical and 4 Horizontal Safety Screws. Screws Included.

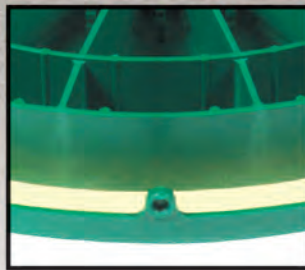

Foamed-in Permanent Polyurethane Gasket.



Concrete Keepers™ Holds up to 70 lbs of Concrete for Added Safety.



Water-TITE™ Joint Vertical and Horizontal Safety Screws

## 4" Effluent Filter and 4" T-Baffle™

86 ft. of 1/16" filtration area.

Increases time between filter cleaning.



EF-4 Combo Includes Filter, Housing and

4" Sch. 40 & SDR-35

NSF®  
800 GPD  
ANSI/NSF  
Standard 46

NSF®  
COMPONENT  
ANSI/NSF  
Standard 46

NSF®  
COMPONENT  
ANSI/NSF  
Standard 46

TB-4-18 Housing  
12/carton

SD-4  
Gas/Solids Deflector

EF-4 Combo 18

### 4" Effluent Filter EF-4

One-piece effluent filter fits in 4" Sanitary Tee.

- Injection molded PolyPro
- Simple to install - Easy to clean

### 4" Sanitary Inlet/Outlet T-Baffle™

Injection molded T-Baffle  
 • Fits 4" Sch. 40 and SDR-35 pipe  
 • Simple to install

- May also be used as Inlet & Outlet Tee

## 6" Effluent Filter and 6" T-Baffle™

244 ft. of 1/16" filtration area.

Increases time between filter cleaning.



EF-6 Combo Includes Filter, Housing and Bushing

4" Sch. 40 & SDR-35

NSF®  
1500 GPD  
ANSI/NSF  
Standard 46

NSF®  
COMPONENT  
ANSI/NSF  
Standard 46

TB-6 Housing

Gas/Solids  
Deflector

### 6" Effluent Filter EF-6

One-piece effluent filter fits in 6" T-Baffle™.

- Injection molded PolyPro
- Simple to install
- Easy to clean

### 6" Sanitary T-Baffle™

Injection molded T-Baffle™.  
 • Injection molded  
 • Fits 4" Sch. 40 and SDR-35 pipe  
 • Simple to install  
 • May also be used as Outlet Tee with Solids Deflector



Erickson, a Wittig vacuum pump (Gardner Denver) and a debris screen fabricated in-house.

"I don't want to be held hostage by waste disposal centers," Greg explains. "We have only two disposal sites in the region, one in Quincy, which is about a 1 1/2-hour round trip, and one in Ellensburg, which is around a 2 1/2-hour round trip."

The Howlands allow two other septic companies — one of which is a competitor — to dump waste at the land application site, which includes two 2 million-gallon lagoons used to store septage before it's land-applied, he says.

The company devotes one full-time employee to land-applying waste. Greg says the lagoons were needed because the company couldn't keep up with the amount of waste coming in, so it needed storage space.

Why help a competitor? The main reason is the additional revenue.

"There's enough work to go around for everyone here, anyway," he adds. "We're not in a cutthroat market."

The company uses two John Deere tractors to disc the waste into the farmland. Land application is restricted to March through December.

## ON THE HORIZON

Looking ahead, the couple expects continued growth. Luanne says some growth will come from investing in more restroom trailers and expanding the company's share of the market for weddings and other special events.

"Greg is a little apprehensive about the cost of restroom trailers, but I feel they're the future of the industry and special events," Luanne says. "There are a lot of outdoor weddings in our area and I believe that trailers are important to people holding those outdoor weddings. I try to join every (wedding-related) group I can to get our name out there."

Greg notes the company is trying to expand its grease-trap cleaning client base by developing relationships with national grocery and restaurant chains.

"I feel we're a mid-sized company," Luanne adds. "So we'll take whatever growth we can get. We have enough employees to absorb future growth for the time being. And Greg and I agree that if we find good employees, we'll hire them and find work for them."

"But no matter what happens, we still want to provide consistent and reliable service," she concludes. "Because those are really the foundation of a solid business." **P**



## He feels the need for speed

Even though Greg Howland is happily married, he still pines for his first true love: a white-and-black 1969 Chevrolet Chevelle Super Sport. With its 396-cubic-inch, 325 hp V8 engine, the muscle car fueled his passion for a high-octane hobby: professional funny car racing.

The cost? A mere \$1,200. The return on investment? Priceless.

"I was a car nut," says Howland, who co-owns Apple Valley Pumping with his wife, Luanne. "I tore down that Chevelle many times, sometimes just because."

Howland started drag racing when he was 17 years old on a quarter-mile strip at the Firebird Raceway in Boise, Idaho, where he grew up. At the time, students from five area high schools competed in races sanctioned by the National Hot Rod Association.

Howland later fell in love again, this time with a 1978 Z-28 Chevrolet Camaro with a 350-cubic-inch V8 engine that, after modifications, generated 350 hp.

"It was not only fast, but it handled corners better, too," Howland says.

In 1998, he moved on to another four-wheeled romance, this time falling for a 1923 T-bucket Roadster, "a full-blown race car," as he calls it. (It's essentially a 1923 Ford Model-T married onto a race car chassis and equipped with a 454-cubic-inch, 600 hp V8 engine.)

"With that car, I raced at the sportsman's level, where you have to win to get paid," he says. "I won \$2,500 with that car in 1999, when I won the American Hot Rod Association World Finals in Spokane."

But the highlight of Howland's racing career came later, after he formed Zeus Racing and became a professional funny car racer, which meant he got paid to enter competitions. In a funny car featuring a 1979 Chevrolet Corvette body paired with an eye-popping, 517-cubic-inch, 2,000 hp engine with a 1471 supercharger, he won the NW BB Funny Car Association championship five times (including consecutive wins from 2015 through 2017).

What's Howland's fastest speed in the Corvette? 214.45 mph, which resulted in his personal-best quarter-mile time: 6.508 seconds, recorded at the NHRA Winternationals in 2016 at the Auto Club

Raceway in Pomona, California.

Surprisingly, Howland says he doesn't like the high speed. Instead, he prefers the acceleration part of the equation, or roughly the first eighth of a mile. "After that, I can't wait for the parachutes to come out," he says.

Howland says that so far, he's avoided any crashes or injuries, though he has crossed the center line a few times.

"A funny car is a different animal than my prior cars or dragsters," he explains. "They're a challenge to drive because they have a short wheelbase. So when you accelerate really fast in a short amount of time, any imperfection in the racing surface can throw you into the wall or across the centerline."



"There's a lot of unpredictability, sort of like riding a bull," he continues. "So you really have to be alert."

How long does Howland plan to keep donning a fire suit and helmet for 200 mph weekend rides?

"I have a crew chief right now, Kenny Gray, and he's the best," Howland notes. "So when Kenny says he's had enough, I'll say I've had enough. Because once you've had the best, you can't go backwards."

As for the Chevelle, does Howland still have it?

"I wish," he says. "I sold it for \$3,000 in 1981. Being a dumb kid at the time, I didn't realize it was on the edge of becoming a collector's item."

"But I have the VIN number and I'm still trying to find it."

## MORE INFO

**Erickson Tank & Pump LLC**  
509-785-2955  
www.ericksonstank.com

**Gardner Denver Inc.**  
866-428-4890  
www.gardnerdenver.com

**Masport, Inc.**  
800-228-4510  
www.masportpump.com

**National Vacuum Equipment, Inc.**  
800-253-5500  
www.natvac.com  
See ad, page 3

**NuConcepts**  
800-334-1065  
www.nuconcepts.com  
See ad, page 42

**Satellite Industries**  
800-883-1123  
www.satelliteindustries.com  
See ad, page 35

**Vacuum Sales, Inc.**  
800-547-7790  
www.vacuumsalesinc.com  
See ad, page 50  
Eastern Supplement, page 2

**Westmoor Ltd.**  
800-367-0972  
www.westmoorltd.com  
See ad, page 28





# YOUR ONE STOP SHOP

## Jurop R260 Specifications

RPM Range	90-1200
Max Vacuum	27.6" / 92%
Max Continuous Vacuum	18" / 60%
CFM at Free Air	363
CFM at 18"	304
Max Pressure	25 PSI
Horsepower	18
Noise at 18"	84 dB
Net Weight	397 lbs.
Oil Tank Capacity	2.44 qt
Recommended Oil	ISO 150
1 3/8" Smooth Shaft	



**IN STOCK!**

**& READY TO SHIP...**

**Scary Fast!**

VARCOHYDRO.COM • TOLL FREE 866-872-1224 • VARCOSUPPLY.COM



SOURCE KEY 10P22





# VACUUM TECHNOLOGY



## Pro-Vac Industrial Pumpout System Ideal for Indoor/Remote Jobs

For: grease trap service pumping, machine coolant pumping-cleaning, remote portable toilet pumping, marina vacuum pump out service, or any pumping and transfer of liquid waste



Made in USA  
Since 1939



Pumps - 35 Thru 230 CFM  
Vacuum (only) & Vacuum/Pressure



PowerPaks - Gas & Diesel Powered  
Belt Drive & Direct Drive

Westmoor Ltd., Sherrill, NY • westmoorltd.com • orders@westmoorltd.com • 1-800-367-0972

## DON'T DRIP DRY YOUR SLUDGE, DEWATER IT OVERNIGHT!

Patent #9,828,274



Dewaters Overnight  
Consistent Results  
Low Energy Use  
Self-Cleaning

>All Stainless  
Steel & PVC  
construction

>Roll-Off Frame  
>Very Forgiving  
>Amazing results

If it will Floc,  
it will work.

In the Round Dewatering  
ITRDewatering.com  
317-539-7511

## tanktrack

Save time and money with  
the **simple septic software**

- ✓ Streamline billing & payment processing
- ✓ Automate outreach for repeat jobs
- ✓ Track waste manifests and land application
- ✓ Become audit ready and worry free
- ✓ Optimize routes, checklists, and more...

Simple monthly pricing | No hidden fees  
Friendly, US-based customer support

Watch our free demo:  
[tank-track.com/free-demo](https://tank-track.com/free-demo)

{603} 277-3206 | info@tank-track.com



**2 proven brands,  
1 world-class manufacturer.**

**AQUATECH™**

**O'BRIEN®**  
Hydro-Jetting Sewer Systems



**AQUATECH® B-SERIES**  
Rear-Mounted Hose Reel Combination Sewer Cleaner



**O'BRIEN® 7000 SERIES**  
Hydro-Jetting Sewer Systems



**AQUATECH® GUARDIAN**  
Combination Sewer Cleaner



**O'BRIEN® 3500 SERIES**  
Hydro-Jetting Sewer Systems

**Hi-Vac Corporation** manufactures a comprehensive line of combination sewer cleaner systems so that you can complete projects of any scope or degree of difficulty.

**DEMAND THE BEST. DEMAND HI-VAC.**

**HI-VAC®**  
**CORPORATION**

[www.hi-vac.com](http://www.hi-vac.com)

117 INDUSTRY ROAD • MARIETTA, OHIO • US: 800.752.2400 INTL: 1.740.374.2306





**Jennie Lyon**  
Contributor

Jennie Lyon is the owner/operator of Jennie Lyon Digital Marketing & Virtual Services. Learn more at [www.jennielyon.com](http://www.jennielyon.com).

# You've Decided to Dive Into Social Media Advertising. What Now?

Good planning and follow-through are required to take advantage of Facebook's huge audience and useful advertising analytics

By Jennie Lyon

**I**t's baffling to think that Facebook was once just a social networking site for Harvard University students. As of 2021, it boasted 2.85 billion monthly users. That's a staggering number.

And as the owner of a small business, it's hard not to get excited by the prospect of all those people seeing your advertisement. There are still plenty of ways that pumping company owners like you can optimize Facebook advertising to help grow your business and attract a fraction of that massive user base.

Facebook paid advertisements are available to anyone willing to create them. If you're on Facebook, you've definitely seen them in one form or another, either right in your face as newsfeed ads or just off to the right as a margin ad. Businesses have also begun utilizing the Facebook Stories function for advertising.

When Facebook first introduced advertising, margin ads were the pioneers. As the site grew and technology improved, "the algorithm" became a hot-button topic, and ads began to eerily seek us out, offering things we didn't know we wanted until we saw them.

➤ It can be tempting to want everyone on Facebook to constantly see your ad. But when they see the same image and copy over and over, viewers tune it out or even get annoyed by it. To avoid this, ensure you set post frequency to no more than five views per user.

Facebook ads are user-friendly and offer flexible models for campaigning and cost. Margin ads are more affordable, but they don't grab attention the way newsfeed ads do. You also have various goals to select from that Facebook uses to dictate how your ad is built and who sees it.

To that end, you'll want to get specific about what your service offers the audience you seek. You can decide if you're creating an ad to raise brand awareness, convert browsers to sales, or simply engage with your audience through Messenger. Furthermore, you'll want to figure that out because —

depending on your goals — you may want to choose different pricing models, selecting between one that charges you based on an ad's impression (amount of reach and relevance) or per-click. Both models have their merits, but you need to mind that marketing budget and use it effectively to get in front of the right faces.

## CONSTRUCTING ADS

To make the biggest impact with your Facebook ad, you need to build the content carefully. So let's break down each element to help your ad stand out:

### Headlines

If you don't nail that headline, your ad will fall flat. You need to get specific about what you're selling. With Facebook ads, your value proposition has to be something consumers need, that solves their pain points, and they can't not click on. That's what will boost your click-through rate and drive customers. Mention what makes you unique and do it concisely (40 characters max) with catchy phrasing. I like to use a subject line tester like CoSchedule ([coschedule.com](http://coschedule.com)) to evaluate my message for posts and emails.

### Imagery

While a catchy headline is excellent, using the right visuals is the most important part of your ad. Facebook's algorithm favors images, meaning your message is more likely to be seen when it has a compelling, relevant image. It also takes up the most space in your ad. When considering the type of image to use, think welcoming, bright, high contrast and incorporate your brand coloring. Regardless of the image, make sure it's as high quality as possible. The recommended resolution is 1080x1080, so make sure you have a crisp, clear picture to present your audience. Nothing makes me question a business' quality and commitment to their work than a low-resolution image in their advertising.

### Messaging

You have room above your image, even on your graphic, and in the link description to write out details that can drive your Facebook ad home. With your link description, you want to get to the point (30 characters) and use active, urgent phrasing. That is where it pays to advertise a specific product or offer, for instance, 25% off on a customer's next septice service.

Make that call to action as clear and appealing as possible. With your post

*(continued)*





**TRAILERS AND  
TRUCK BODIES**  
INCORPORATED

**Custom Manufacturer of  
Vacuum Trucks & Trailers**

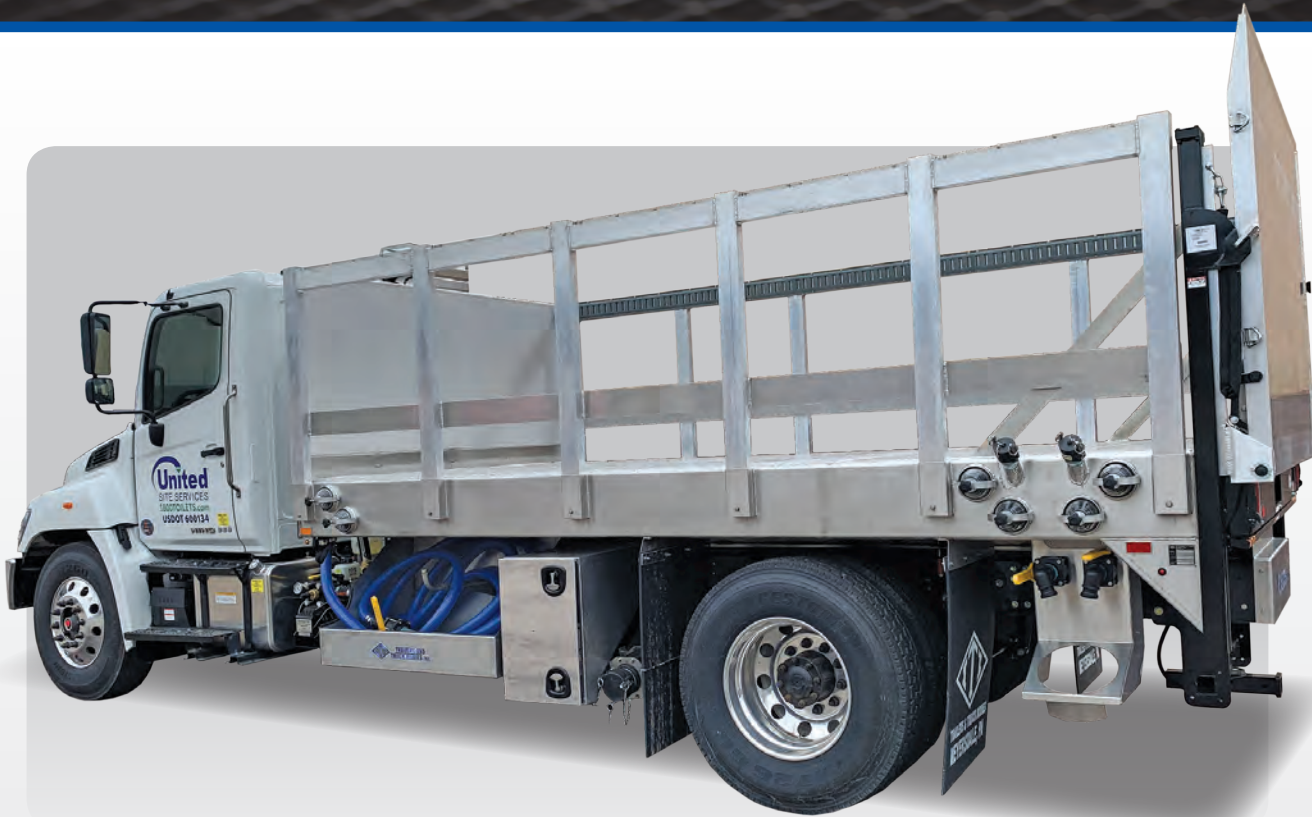

5500 Gallon Stainless Steel Tank ◊ NVE 4307 Blower



5000 Gallon Carbon Steel Tank ◊ 607 NVE Pump

**We  
Manufacture  
& Service  
What  
We Sell.**

ASME Certified

Building DOT 407/412 Equipment



Stainless Vacuum  
Trucks & Trailers



Grease Trap  
Pumper Trucks



DOT 407 - 412  
Cargo Tank Trailers



Portable  
Restroom Trucks



Aluminum Vacuum  
Trucks & Trailers



Carbon Steel Vacuum  
Trucks & Trailers

To learn more about  
ITI Trailers and Truck Bodies,  
call **1-888-634-0080**  
or visit  
**www.itimg.com**



# Tank World Corp

ALL MAJOR BRANDS IN STOCK AND READY TO BUILD

COME GET A  
SPOOKTASTIC  
TANK  
FROM TANK WORLD



Financing Available



**We build Vacuum trucks, Septic trucks,  
Porta Potty trucks, and Body swaps.**

We can do Steel, Stainless Steel and Aluminum.

**NOT JUST BUILDING TRUCKS BUT BUILDING RELATIONSHIPS**  
Parts and Accessories In Stock

ASME & R stamp accredited

UL 142

**www.tankworldaz.com**

12001 W. Peoria Ave  
El Mirage, AZ 85335

Jerry's cell 623-680-2037  
tank.jerry1@gmail.com

Office 623-536-1199  
Fax 623-935-4514  
service@tankworldaz.com

## BUILDING THE BUSINESS

text on newsfeed ads, you have a lot of room to expand your copy, but again, people don't want to read a wall of text to find out what you have to offer. Stick to 125 characters and use things like testimonials or statistics to reinforce your quality service.

### AFTER THE POST

One part of many Facebook ad campaigns that most businesses fail to consider is including a post-click landing page. These create a focused space for you to inform, attract and convert your target audience. Here is where you can offer freebies or incentives. It requires targeted copy and content, but it makes anyone who lands there more likely to buy as it expands on the offer you made in your ad.

Too many people think once their ad is made and circulating, they're done. Don't fall into that trap. Facebook offers tools and analytics for users to review. After you've let your ad run for a few weeks or months, have a look at how it's doing. How big of an impression is it making on your target audience? What does Facebook's relevance rating think of it? Are you getting a high or low click-through rate?

An A/B testing tool lets you create variations of your ad. You make two with different sets of copy and imagery, then compare to see which performs better. It's worth the effort and investment to broaden your research and find out what works.

Review the data and make changes to improve your advertising impact. But be judicious! Just because you can change doesn't mean you need to. Don't go tweaking every day. Otherwise, you'll skew the analytics, and you'll never know what did or didn't work in a given period. Even if the numbers seem low, don't panic. Be patient, then change things up based on the trends you're seeing.

The last advice I have is to pay attention to post frequency. When you set up your advertising on Facebook, you can adjust how often individual users see your ad. It can be tempting to want everyone on Facebook to constantly see your ad. But when they see the same image and copy over and over, viewers tune it out or even get annoyed by it. To avoid this, ensure you set post frequency to no more than five views per user. That helps keep it fresh and relevant, leading to a higher click-through rate. As far as costs go, if you're budgeting for cost-per-click, the higher the frequency, the more you pay.

### SET A STRATEGY

While those posts may seem like small 1080x1080 squares, there is a lot that you need to consider and collect to optimize their impact. With a specific offer, excellent copy and imagery and a clear strategy that you're ready to review and tweak as needed, you can start to build some meaningful, eye-catching ads that will get your wastewater services noticed. **P**

- » New & Used Equipment
- » Digital Editions
- » Free Subscription
- » Online Exclusives
- » E-Alerts

[www.pumper.com](http://www.pumper.com)

**Pumper**



**CRANE**

PUMPS & SYSTEMS

CHOPPER  
NON CLOG  
SUBMERSIBLE  
DRY PIT  
HORIZONTAL  
VERTICAL

**envie<sup>3</sup>**

**HAS YOU COVERED**

Visit [envie3.cranepumps.com](http://envie3.cranepumps.com) to learn more!



# progress tank

Call or Text  
(913) 515-4318



**2023 International  
4000 Gal aluminum  
w/ NVE Pump or Blower**

**1250 Gal Restroom Trucks  
FORD F-550 & RAM 5500  
Units available for NOV & DEC delivery**



[sales@progresstank.com](mailto:sales@progresstank.com)



[www.progresstank.com](http://www.progresstank.com)



## THINKING OF SELLING YOUR PORTABLE SANITATION BUSINESS?

YOU DESERVE EXPERT, PROFESSIONAL REPRESENTATION

WE WORK FOR YOU, THE OWNER,  
TO MAXIMIZE THE VALUE OF YOUR BUSINESS



**DAMON POWELL**  
407-765-9440



**ED MEDVIC**  
727-486-0306



- ✓ 133 closed transactions
- ✓ 55 years combined industry experience
- ✓ Free consultations
- ✓ Zero upfront cost

[www.FMCadvisors.com](http://www.FMCadvisors.com)





# HAPPY HALLOWEEN



**ISUZU**  
MD950



SATELLITEINDUSTRIES.COM | INFORMATION@SATELLITEINDUSTRIES.COM | 1.800.883.1123







# Corporate Tax Analysis Is Helpful In a Challenging Economy

A qualified financial expert can wade into the intricacies of your pumping company to find ways to raise your bottom line

By Joan Koehne

**C**orporate taxes take a big bite out of small businesses. With today's high inflation rates and the threat of an economic recession, small-business owners are looking for every possible way to save money.

Is your pumping business taking advantage of every tax break available? By reducing the corporate tax you owe, you'll keep more money in your pocket, making it easier to finance and grow your business. Roman Basi, attorney and certified public accountant at the Center for Financial, Legal and Tax Planning in Marion, Illinois, recommends a variety of strategies to save money on corporate taxes.

"What comes to the forefront is, 'How can they structure their company to save taxes?' " he says.

When advising clients, one of the first things Basi checks is the legal and financial structure of a company. He performs a tax minimization analysis to compare the tax impact of different organizational structures. Tax classification varies, depending on the way an entity is organized.

For example, many small businesses form their legal entity as a limited liability company, S corporation or disregarded entity. The Internal Revenue Service taxes these entities through the owner's personal income tax form. All income and expenses flow to the business owner's 1040. Hence, these entities qualify for "flow-through taxation."

## CHANGING THE DESIGNATION

The business owner files an annual income tax return and a separate corporate tax return (if an S corporation) for the business yet the corporation pays no taxes. Although a flow-through taxation designation may yield the most favorable tax outcome, oftentimes it's worthwhile to consider alternatives.

The tax minimization analysis answers the question: What happens if we change this company to a C corporation, which is not a flow-through entity? Taxes are paid by the company instead of the business owner. To create a clear and understandable comparison, Basi's team develops a mock-up of financial statements showing the tax implications if the company switched to a C corporation. The tax minimization analysis considers alternatives to flow-through tax designation.

The results can be surprising. One of Basi's business clients with a flow-through tax designation was paying taxes at a rate of 37%. By restructuring the company as a C-corp, the tax rate dropped to 21%.

“It's crucial whenever you're dealing with tax law and tax advice to speak to someone that's not just a CPA but a tax attorney who specializes in the federal tax laws. They interpret what they see on the tax returns and financial statements as they relate to the tax code.”

– Roman Basi

"The tax minimization analysis goes a long way for small businesses," Basi says. The analysis especially is valuable for owners preparing to sell or transfer their business. Sellers want to maximize value and earn enough money to transition to a new career or enjoy their retirement. The analysis helps business owners make educated decisions based on financial data, not guesswork or gut instinct.

## CHOOSING AN ADVISER

When it comes to business finances and taxation, a certified professional tax adviser simplifies the decision-making process. Basi recommends selecting a tax adviser who does more than just prepare tax returns and financial statements.

"I think it's crucial whenever you're dealing with tax law and tax advice to speak to someone that's not just a CPA but a tax attorney who specializes in the federal tax laws," he says. "They interpret what they see on the tax returns and financial statements as they relate to the tax code."

Another factor to consider when choosing a tax consultant is the size of the tax advisory service.

"They should seek out advisers that are similar in size to their company," Basi says. "Does a small, three-man operation want a 100-person law firm or accounting firm giving them advice? No. Their interests aren't aligned that way."



One of the benefits of working with tax advisers is their knowledge of current state and federal tax laws.

“There’s nothing new that business owners absolutely need to know about right now. What they must know about is what’s going to expire,” Basi says.

The most prominent tax legislation about to expire is the federal estate tax exemption, which sunsets at the end of 2025. Currently, a person can pass away and not pay any federal estate tax if they own up to \$12.06 million in assets, doubled to \$24.12 million if married. If Congress doesn’t act on this legislation before it expires, the federal estate tax exemption reverts to \$5 million in total assets, adjusted for inflation (estimated to be \$6.6 million), but not doubled for married couples.

“There’s been no discussion on whether it’s going to be extended or not. People have to start planning,” Basi says. Business owners should calculate what their assets are worth. If assets are above the federal estate tax exemption, they may end up paying 40% in federal estate tax. Additionally, state estate tax laws don’t always align with the federal estate tax laws. As the end of 2025 draws closer, Basi recommends keeping an eye on federal and state estate tax exemptions.

### HUNT FOR DEDUCTIONS

Another thing to keep an eye on are tax deductions. They lower a business entity’s taxable income, so the business owes less to Uncle Sam.

One important deduction is the qualified business income deduction. The QBI prevents flow-through entities from paying taxes on 20% of their income. “Most business owners know that clause, but some do not. Some of them are not taking advantage of that,” Basi says.

Another one of the most common tax deductions for small businesses is the meals deduction. Business meals are tax deductible. So, keep track of restaurant receipts and meal expenses for corporate events like employee picnics and holiday parties. Also track expenses for meals when traveling for business, entertaining a client or attending business conferences.

Mileage is another expense to track, both for fleet vehicles and private vehicles used for business purposes. The current standard business rate set by the IRS is 62.5 cents per mile. In addition to mileage, business owners can deduct the depreciation of work automobiles placed into service in 2022.

Small-business owners with a home office can claim their office as a tax deduction. Generally, only the portion of their home used exclusively and regularly for conducting business can be claimed. Additionally, the business owner can deduct certain expenses related to the home business, like utilities, rent, mortgage interest and insurance.

Tax credits also are available for retirement plan startup costs and solar energy project investments.

Finding ways to save money on taxes is worth the required time and energy. Taxation typically isn’t always top-of-mind for busy pumpers who are focused on providing great customer service. That’s why it pays to consult with a tax adviser who will look at tax law, tax deductions and tax credits to find all of the money-saving strategies available. By reducing the corporate tax you owe, you’ll have more capital to invest in your business. **P**

### HAVE SOMETHING TO SAY?

To share your opinions about *Pumper* articles just send an e-mail to our editor at: [editor@pumper.com](mailto:editor@pumper.com)

**KeeVac Industries, Inc.**

Restroom • Septic • Grease / Trucks • Slide Ins • Towables

Take advantage of Section 179 or 168(k) in 2022 for up to \$1M on qualifying equipment.

**Do not hesitate! Now is the time to place your truck orders before the savings expire. Plan ahead and get your tax advantage today!**

Visit [www.section179.org](http://www.section179.org) for more information

**Portable Restroom Trucks**

**Septic & Grease Trucks**

**Slide-In Units**

**KeeVac Industries, Inc.**

**866-789-9440**

**[www.keevac.com](http://www.keevac.com)**





**2023 Freightliner GREASE TRUCK** | NVE 607, Heated ProVac cabinet, 950 SS tank NON-CDL



**2023 Kenworth T880 CALL FOR PRICING** | 20/20/46, Ultra-Shift, NVE 4310, CAT 660 jetter package, LED lights, LED strobes, 4-camera package, NAV system, alum. tank



**2023 T880 Kenworth Decant CALL FOR PRICING** | (200/4000/1400) NVE 4310, CAT jetter package



**2015 International 4300 IN PRODUCTION** | ISB250/250HP Cummins, Allison 2500 RDS, 12/21, 2,650 gallon aluminum tank, NVE 607 or B500 package



**Used 2021 T370 Kenworth GREASE TRUCK**

300 HP, Allison Auto, 33,000 (G.V.W.R.)  
1800 gallon stainless steel (ITI) tank,  
NVE 607 ProMax package, heat collars (heat through tank),  
heated cabinet for ProVac unit w/hydraulic lift,  
Hannay hose reel w/100' 2" hose in heated cabinet.



**2023 T680 Kenworth CALL FOR PRICING** | NVE 4310 blower, full wet system w/hydraulic cooler



**7000 - 9000 Gal. Aluminum Tri-Axle Trailers** | Air ride suspension (tri-axle), pump platform, bright finish, LED lights, Betts valves.



**Pumps For Sale**

NVE 866, 4307 and 4310 Slim Packages Available



**NVE**  
NEW ENGLAND DISTRIBUTOR



**Need Equipment? Contact Us We Can Get It.**

**DRE**  
RESTROOM TRAILERS

SALISBURY, NC  
Restroom Trailers



**We Have Units In Stock For Immediate Delivery**

**Production Spots Available**

As a luxury trailer manufacturer we offer a variety of different models, so our trailers can be used for a wide variety of industries. We will work with you, listen to your needs and will custom build to your specs!

**» Built to Last**  
**» High Quality Parts**

**NASCAR Drivers Team Up In New Manufacturing**

**DISTRIBUTORS WANTED**



330.716.2004 • 704.633.6098 • www.dretrailer.com

**ROEDA**

We Get You Recognized

Covering The Portable Toilet World With  
**CUSTOM & STOCK DECALS**

Call now for custom graphics at  
**800.829.3021**

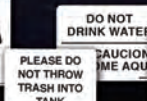

Shop online now at

**STORE.ROEDA.COM**

roeda.com | info@roeda.com | 20530 Stony Island Ave. Lynwood, IL 60411



# DrainMaster®

## Concentrated Drain Cleaner

### PURPOSES:

- » Opens problem drains
- » Removes buildup
- » Keeps drains free-flowing
- » Maintains grease traps
- » Controls odors



### USES:

- » Drains, traps, plumbing lines
- » Commercial grease trap
- » Residential waste systems
- » Sluggish waste lines
- » Problem odors

## Other Essential Products for Septic Professionals from Cape Cod:



### Tank Health

Jump Start is designed to accelerate the health of septic tanks after being pumped.



### Drainfield Care

After Shock restores drainage to clogged and sluggish drainfields and structures, eliminates odors.



### Tank Maintenance

CCLS maintains septic systems, digests waste, unclogs plumbing waste lines, eliminates odors, reduces organic buildup.



### Grease Killer

BIO-REM E-D breaks down grease, digests waste, eliminates odors, unclogs drains.



Cape Cod Biochemical  
Pocasset, MA

Green Products for Septic Professionals | Since 1976

800-759-CCLS | [www.SepticOnline.com](http://www.SepticOnline.com)

Easy online ordering using our new Customer Portal!





# Massachusetts may require nitrogen technology for all of Cape Cod

By David Steinkraus

Indications are Massachusetts will change its Title 5 onsite rules to require nitrogen-reducing technology on all of Cape Cod. The Massachusetts Department of Environmental Protection has contacted town managers in advance of a general notice about the change, reported Cape Cod news organizations.

Changes may require upgrades of all existing systems within five years after the regulation takes effect, which may give towns the option of applying for a watershed permit, allowing them to tailor solutions to their particular circumstances.

Four communities already hold a single watershed permit for Pleasant Bay on the eastern end of Cape Cod. The permit was issued in 2018 and was the first in the state. It requires the communities to cut nitrogen flow into the bay by 39,022 pounds (17,700 kg.) in 20 years. Three communities are building sewer systems. The fourth is reducing fertilizer use on its municipal golf course, improving drainage, considering alternative technologies and planning a small treatment system.

Stanley Andrews, who chairs the board of health in Bourne, told the *Cape Cod Times* that some Title 5 change by year's end is a good possibility if for no other reason than the lawsuit filed last summer against the state and the towns of Barnstable and Mashpee.

In the lawsuit, the Conservation Law Foundation asked a court to suspend permits for conventional septic systems in the two towns until they develop a plan to stop nitrogen pollution. For years the towns and state have known that nitrogen pollution from septic systems is fouling waterways, the foundation argues in its suit. By continuing to approve permits, the towns and state have allowed pollution to continue and thus have violated state law, the suit asserts. Instead of conventional septic systems, the foundation wants advanced treatment units to be required when onsite systems are installed or when properties are transferred.

Thirty watersheds on Cape Cod have nitrogen total maximum daily loads approved by the U.S. Environmental Protection Agency.

Brewster Town Administrator Peter Lombardi told [wickedlocal.com](http://wickedlocal.com) that the process of changing Title 5 is only beginning. A meeting with town officials would be followed by a public comment period, he said.

## Maryland

Anne Arundel County notified installers that the state has ordered changes for onsite permits and applications in the county.

Site plans will now be required for all repair applications. The county Health Department will conduct a perc test as it has done, and will then send a letter to

the property owner, applicant and contractor recommending minimum onsite requirements. It will be up to the property owner to decide who will create and submit the site plan.

Site plans must be signed and dated and should include information such as locations of nearby structures, locations of wells within 100 feet of the property, swimming pools, layout and design of the proposed system, rights of way and easements, and anything that could impede installation of a system.

Permits for conventional tanks will no longer be automatically issued, and the process for perc and dry wells will also change.

## California

Directors of the Sonoma County Water Agency voted in June to conduct a study of wastewater treatment options for properties along the lower Russian River. Homes and businesses in Monte Rio and Villa Grande rely on onsite systems that don't meet current standards and could discharge untreated effluent into the river and its tributaries, according to a press release from the county.

Brelje & Race Consulting Engineers of Santa Rosa will conduct the \$425,000 study of options including one or more alternatives recommended by a citizens advisory panel and representatives of local governments. The next step would be a pilot project to begin upgrading onsite treatment.

Sonoma County supervisors will consider revisions to the county's onsite treatment manual in early 2023. Information about the proposed changes is available at [permitsonoma.org/divisions/engineeringandconstruction/wellandsepticssystemsepticssystemsowtmanual](http://permitsonoma.org/divisions/engineeringandconstruction/wellandsepticssystemsepticssystemsowtmanual).

## Texas

The chair of the Hood County Republican Party lost a court fight over maintenance of his onsite system. A judge found Steve Biggers has not been maintaining his system in accordance with county regulations.

Biggers has said publicly that he believes trained homeowners should be able to maintain aerobic systems instead of being forced to contract for the service, reported the *Hood County News* in Granbury, Texas. Court testimony showed Biggers had taken training from the Texas A&M AgriLife Extension Service.

Some counties accept that training as sufficient, but Hood County requires homeowners to complete a more intensive two-day training through the Texas Onsite Wastewater Association if they want to maintain their own systems.

County Attorney Matt Mills said the court decision means that if Biggers doesn't comply, the county could consider asking a judge to hold him in contempt of court. **P**





# FRUITLAND

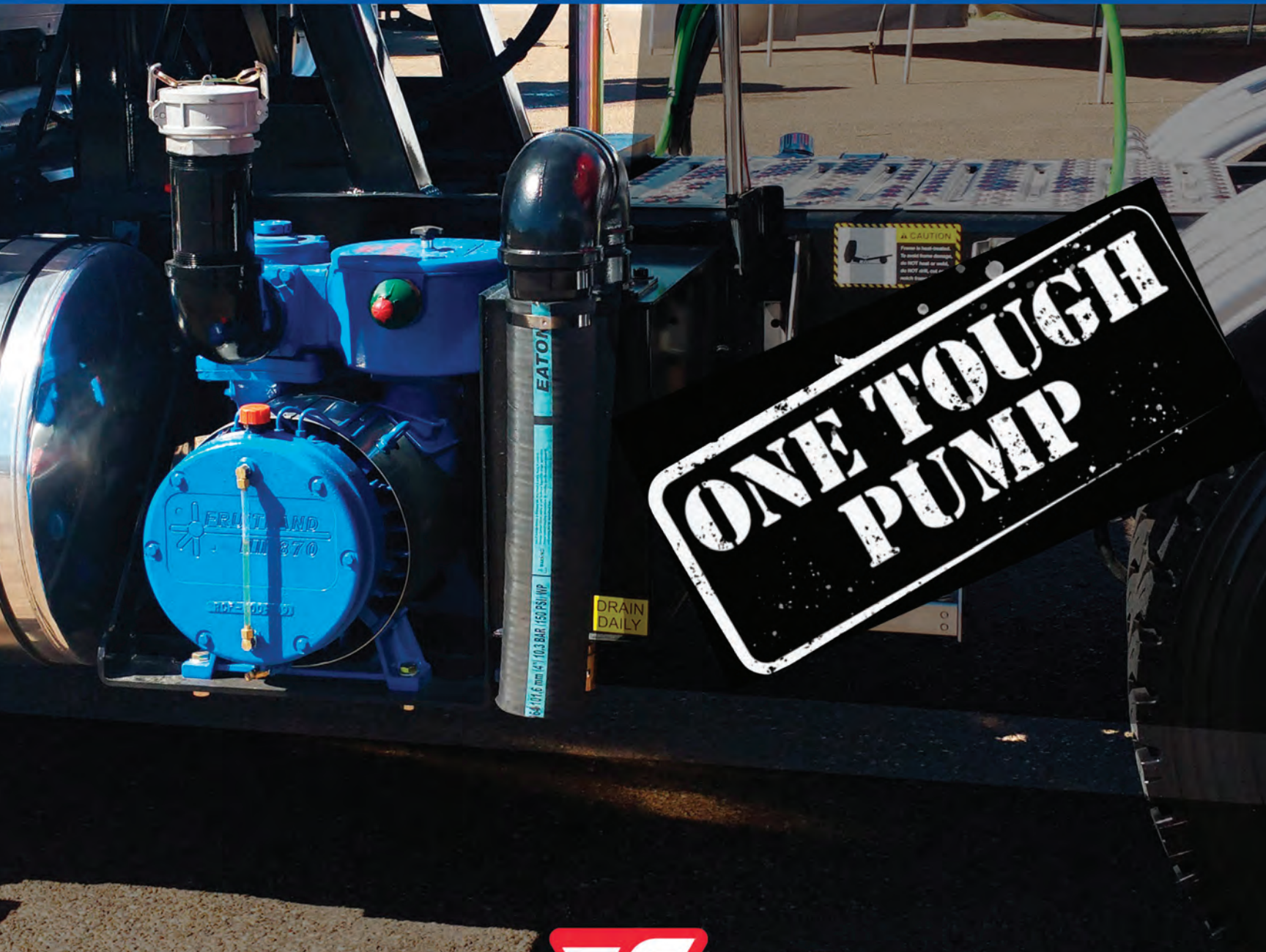

LET'S SHAPE THE UTURE TOGETHER

We are here with you! Join us in our goal to shape the future of the industry. With proven quality, outstanding products, and continuous innovation.

[www.fruitlandmanufacturing.com](http://www.fruitlandmanufacturing.com)





# ROBINSON VACUUM TANKS

Call (814) 933-0927, visit [www.RobinsonTanks.com](http://www.RobinsonTanks.com), or email [sales@robinsontanks.com](mailto:sales@robinsontanks.com)

— OFFERING SALES, PARTS & SERVICE —

VISIT OUR WEBSITE TO SEE ALL AVAILABLE INVENTORY

Like Us On Facebook



## PORTABLE RESTROOM TRUCKS

- Tank Sizes from 980 - 2000 Gallons
- Choose from Aluminum or Steel Tanks



## VACUUM TRUCKS

- Tank Sizes from 1200 - 5500 Gallons
- Aluminum Tanks



## SLIDE-IN TANKS

- Tank Sizes from 300 - 1500 Gallons
- Aluminum Tanks
- Flanged/Dished or "Soup Can" Styles

**NUCONCEPTS**  
VERY IMPRESSIVE PORTABLES

## WE CALL IT MAJESTIC

**These Are Royal Accommodations**

Since inventing the first VIP (Very Impressive Portable) over 26 years ago, NuConcepts continues to innovate with our MAJESTIC 2 or 4 unit luxury restroom trailer.

Visit Our Website and Video at [www.NuConcepts.com](http://www.NuConcepts.com)  
CALL FOR YOUR LUXURY OPTIONS AND CUSTOM QUOTE

**Self Contained-Solar Powered-Flushing Porcelain Toilet**  
Available as Stand Alone or Trailer Configurations

VIP Interior    Prestige    Diplomat    Deli Sink    Hand Wash Sinks

**NUCONCEPTS**  
VERY IMPRESSIVE PORTABLES

800-334-1065 | 909-930-6244  
45652 Division St., Lancaster, CA 93535 | [www.nuconcepts.com](http://www.nuconcepts.com) | [info@nuconcepts.com](mailto:info@nuconcepts.com)

PROUDLY MADE IN THE USA

## DEWATERING

Dewatering Unit • Polymer Injection • Sludge Pump  
Hoses • Working Platform • Polymer Sales and Testing

- » Pass the paint filter test in 24 hours
- » No waiting, Equipment is in stock
- » Visitors welcome at our dewatering facilities

**Debris Screener**

We do one thing to perfection — Dewater Liquid Waste!

**AQUA-Zyme Disposal Systems**

Call us at (979) 245-5656  
[zymme@aqua-zyme.com](mailto:zymme@aqua-zyme.com)  
[www.aqua-zyme.com](http://www.aqua-zyme.com)

FINANCING AVAILABLE



***Sonetics***<sup>®</sup>

**AVOID MISCOMMUNICATION  
& INCREASE SAFETY  
AROUND HEAVY EQUIPMENT**



**Tackle the Challenges of Unexpected Distractions  
and Frequent Noise**

Learn how your team can stay focused, connected and aware of danger at  
[sonetics.com/prevent-miscommunication](https://sonetics.com/prevent-miscommunication)



# Let's Teach How to Extend the Life of Onsite Systems

Tell homeowners about proper maintenance — and preach getting rid of garbage disposals



In Snapshot, we talk to a member of a state, provincial or national trade association in the decentralized wastewater industry. **This time we visit a member of the Maryland Onsite Wastewater Association.**

**Name and title or job description:** Mike Sample. I'm the owner and president of Sample Excavating. I'm also a service technician for Onsite Septic Inspection & Services.

**Location:** Glen Arm, Maryland

**Services we offer:** At Sample Excavating, I install systems and do design work for innovative and alternative systems, and I'm a stocking dealer for Hydro-Action. At OSIS we service, inspect and maintain best available technology systems and answer alarm calls. That also gives us a chance to educate homeowners, which I think is one of the most important things we do. I talk to people for as long as they want to listen about simple care and maintenance.

**Age:** 64

**Years in the industry:** I've been a licensed disposal contractor for 44 years, but I think I probably put my first septic system in when I was 16. My father was in the excavating business and I was the backhoe operator. I would get subbed out to do digging for plumbers and get left on jobs by myself, doing the whole project. One day the light bulb went on and I thought maybe I should go into business for myself.

**Association involvement:** I joined the Maryland Onsite Wastewater Professionals Association about 15 years ago, not long after it started. I've done some volunteering and been involved in panel discussions, and I usually have a vendor booth at the conferences.

**Benefits of belonging to the association:** Training and education are key benefits. It also brings together all the different branches of the wastewater industry — pumpers, installers, regulators — to share ideas and have a voice in the formation of policies and regulations. And what really sparks my interest is they're getting ready to build a training facility where they're going to have all the different treatment technologies and disposal systems (drips, mounds, pressure dose systems) on site and working. I'd like to see it opened up to the general public as well, to educate them because people don't want to get away from the old-time technology.

**Biggest issue facing your association right now:** Keeping the membership and getting more people interested and involved. I wish company owners would get their employees involved. I'd also like to see



Mike Sample with a Ford Transit service van.

the association put out public messages on how to take care of a system — simple things that can make it work properly and prolong its life, and alternatives to things that cause problems like quilted toilet tissue, wipes and detergent pods.

**Our crew includes:** At Sample Excavating, I'm basically a one-man operation. I still do some of the physical work but I sub out a lot of the excavating to other installers and mostly concentrate on designing. At OSIS I am part of a really good team — three other service technicians, a great office staff, and the owner, Nancy Minahan — one of hardest-working people I've ever worked with, but always fair and supportive. I've worked for them for about eight-and-a-half years. Going from being a one-man show to being part of a group is very rewarding. You've always got somebody watching your back. We help one another and take turns being on call.

**Typical day on the job:** Every day is different. I might be doing a layout on an innovative system, delivering a pretreatment system, working with an installer, operating equipment. A typical day with OSIS is doing service visits (checking the sludge levels, changing filters, making sure systems are working properly, fixing what needs to be fixed) and reviewing everything with the homeowners.

**The job I'll never forget:** I design a lot of drip disposal systems. A couple years ago, I put one in, it was working and everything seemed fine, but the filter would get clogged every week. It was driving me crazy.

(continued)



# POWER THRU™

Sewer & drain  
tools built  
to prevail.

Trust MyTana equipment to find and fix tough problems quickly. Our pro-grade cameras, hydro-jetters, cable machines and accessories prepare you for any challenge. And everything comes backed by our legendary service team.

MS11-NG2  
inspection system  
for 3"-6" lines



[www.MyTana.com](http://www.MyTana.com) ■ (866) 369-6353

# MyTana

**INSPECTION SYSTEMS CABLE MACHINES JETTERS LOCATORS**

**CABLE ATTACHMENTS NOZZLES HOSE PARTS TOOLS FACTORY DIRECT SUPPORT**



The woman and her adult son were very cooperative. They didn't have a garbage disposal, weren't flushing whatever. I scraped some of the crud off the disc filter and laid it on top of the manhole to take a picture of it, just to see if somebody else had an idea. When I blew it up it looked like grass seed. Then I saw it moving. The system had old terra cotta pipe and it was overwhelmed with drain flies. It was their larvae that were clogging the filter. The owner flushed all her drains with vinegar and baking soda to kill them off and then I strapped a couple bags of moth balls around the recirculation pipes and they haven't had a problem since.

**My favorite piece of equipment:** I love my mini-excavator, a Yanmar ViO35. I wish I'd had that 30 years ago. We'd get on tight sites and I'd end up digging pipe repairs with a shovel rather than listen to a homeowner gripe about lawn damage from a big backhoe. There are a lot of jobs we used to do with a big rubber-tired backhoe that can now be done with a mini-excavator. They can be used to set pre-treatment systems, which are fiberglass, not concrete. Tracked skid-steers are another thing that really made the world better.

**Most challenging site I've worked on:** A few years back, I designed a low-pressure dosing system on a lot where the septic reserve area was in a triangle shape. Pressure-dosed systems have to be balanced so there's even distribution over all the trenches — which was difficult because I had one trench 40 feet long, one 80 feet, and one 60 feet. It was one of the hardest challenges I've had, to work out all the calculations to get that water to dose the whole system evenly. But it was rewarding to turn the pump on and see that each trench had the same pressure.



▶ Sample and Ellie (white Boxer) load a Hydro-Action nitrogen-reduction system and AK Industries tank on a Lamar flat-deck trailer.

**Oops, I wish I could take this one back:** Any time I broke away from the onsite septic trade — doing construction management, using my equipment for something else — I ended up thinking, “What am I doing here? Why am I doing this?” The worst thing I've gotten into was digging graves. I had done a cemetery expansion where you put the crypts in. It was proposed to me that it was just like septic work because you're excavating the site and setting concrete vaults. So that wasn't bad, but afterwards I started doing the grave openings and that was something I was real sorry I got involved in. It's not something you can plan ahead of time so you might get pulled off of another job. They don't cancel funerals because of bad weather and I had some terrible situations — 5-inch rainstorms, frozen ground. And you have to set up the tent and the lowering device, and then coordinate with the funeral director who has to be present for the lid closing. You basically spend your whole day there.

**The craziest question I've been asked by a customer:** I've had everything from, “Can we flush stink bugs?” to people asking me to cheat on perc tests by digging the holes ahead of time and filling them with good material. What I get all the time is people asking if they can build decks over their systems — which is fine if they listen to me when I say no but nine times out of 10 they don't.

**If I could change one industry regulation, it would be:** Prohibiting garbage disposals in private residences, or, if permitted, that it be mandatory to have a grease interceptor on the kitchen waste drain.

**Best piece of small business advice I've heard:** Early on I'd complain about tough sites and things, and one of the old pumpers told me, “The only people who don't have any problems are the people who don't do anything.” I took that as, “You'll figure it out, just do it.” I also take inspiration from a quote in Proverbs: “Entrust your work to the Lord and your plans will succeed.” I try to live like that.

**If I wasn't working in the wastewater industry, I would:** When I retire, I may continue to do design consulting but I'd like to get involved in some kind of organic food-producing sustainable agriculture. It's basically working with the same principles — taking care of the soil, the water, what Mother Nature gave us, in a way that the next generation can use it. That's how I look at the septic business. I'm more of an environmentalist than a businessman.

**Crystal ball time — This is my outlook for the wastewater industry:** What I'd like to see is advanced treatment technologies, aerobic treatment technologies, drip dispersals, become the industry standard, not something considered “alternative.” For a few years in Maryland around 2014, they were requiring all new homes to have a BAT system, and then we had a political change and it got kicked back so now those systems only go into areas with poor soil conditions or where it's close to a body of water. But knowing what I know and seeing all the different systems, it's like, if you only knew how much of a difference it makes. **P**

- Compiled by Betty Dageforde



▶ Sample using a CASE 580 backhoe on a tank installation.



# BUILT TO WORK THE WAY YOU DO.



Made in the USA

[www.pikrite.com](http://www.pikrite.com)

800.326.9763

**pikrite**



Belt filter presses featuring innovative features that provide high performance in a compact high value package.



Bright Technologies offers complete Belt Filter Press dewatering systems that are skid or trailer mounted. We design and manufacture the skid equipment package for high throughput, low maintenance, superior cake solids and ease of operation.



**Contact Us Today!**  
**800-253-0532**

127 N. Water St., Hopkins, MI 49328

[www.brightbeltpress.com](http://www.brightbeltpress.com)

**ABBOTT RUBBER**  
COMPANY, INC.  
**THE HOSE &  
FITTINGS EXPERTS**



1311 MEACHAM RD., ITASCA, IL 60143  
(847) 952-1800 (800) 852-1855 FAX (847) 952-0156  
E-MAIL [sales@pumperhose.com](mailto:sales@pumperhose.com) WEBSITE [www.pumperhose.com](http://www.pumperhose.com)



# Marsh

Kalkaska, MI

**INDUSTRIAL**

p: 231.258.4870 • f: 231.258.2019 • sales@marshind.com

**800.952.1537 - WWW.MARSHIND.COM**

## VACUUM SEPTIC UNITS

*Thank You  
General Sanitation  
for the purchase  
of a new tank.  
It was a pleasure  
working with you!*



## PORTABLE TOILET UNITS



*Portable  
Toilet  
Restroom  
Service Units*

## DOT INDUSTRIAL VACUUM UNITS

*DOT Code &  
Non-Code  
Hoist &  
Rear Door  
Options*



## SLIDE-IN UNITS

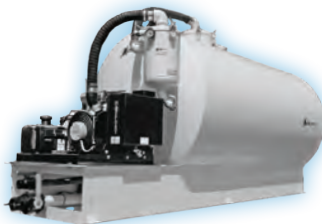

*Various Sizes Available*

## MINI VAC TRAILERS



*Industrial Units DOT Code & Non Code*

**Quality People Doing Quality Work**



Join us on Facebook See the progress of some of our units in the making.

Check out our website for more information: [www.marshind.com](http://www.marshind.com)



**BEST SOFTWARE FOR THE INDUSTRY**

**SAVE UP TO 97.5%!\***

- Save your precious resources with Summit!
- Best Industry routing available!
- Worry-free billing and accounting
- Mobile apps for Route Management and Inventory Management

\*Savings based on competitor's recent "initial" cost. ...Needless to say, customer now uses Summit!



**41 years dedicated to the industry**

Route Management | Dispatching | Mobility | Proof of Service  
Service Reminders | Billing/Receivables | Inventory Control

Portable Restrooms | Roll-Offs | Temporary Fencing  
Septic | Grease | Drains | Plumbing | Others

**Summit**  
array

Ritam Technologies, LLC  
USA/Canada 800-662-8471 Int'l 925-478-2732  
info@ritam.com www.ritam.com

Watch demos OR call  
for a live demo



**PASSION. FOCUS. EXECUTION.**



**OI Is DEDICATED To YOUR SUCCESS**

**OI OPTIMUS  
INDUSTRIES**

Elkhart, IN | 574.226.0691 | info@oirestrooms.com | oirestrooms.com



**NK SERIES ▼**



9.1 to 37.8 GPM  
up to 5075 PSI  
30mm Solid Keyed Shaft  
1450 & 1750 RPM Options

**NK-MI SERIES ▼**



12.5 to 37.8 GPM  
Up to 5075 PSI  
13T 16/32 DP Hollow Shaft  
SAE J744 B Flange  
1450 & 1750 RPM Options

**VX / VXX SERIES ▼**



15.9 to 52.8 GPM  
up to 5100 PSI  
35mm Solid Keyed Shaft - VX  
40mm Solid Keyed Shaft - VXX  
1000 RPM

**VX-MI / VXX-MI SERIES ▼**



15.9 to 52.8 GPM  
Up to 5100 PSI  
14T 12/24 DP Hollow Shaft  
SAE J744 B Flange  
1000 RPM

**HXR SERIES ▼**



32.9 to 104.4 GPM  
Up to 4350 PSI  
50mm Male Solid Shaft  
1500, 1800 & 2000 RPM Options

**HXR-MI SERIES ▼**



32.9 to 104.4 GPM  
Up to 4350 PSI  
14T 12/24 DP Hollow Shaft  
SAE J744 C Flange  
1500, 1800 & 2000 RPM Options

# UDOR USA Offers a Complete Line of Plunger Pump Models for the Sewer Cleaning & Water Jetting Industries



500 Apollo Drive  
Lino Lakes, MN 55014  
Ph: 651-785-0666  
Fax: 800-732-2670  
info@udorusa.com

Visit us online at [www.udorusa.com](http://www.udorusa.com)  
or SCAN the QR Code - ▶



## EASILY MOVE RESTROOMS

### Super Mongo Mover®



- Move ADA Restrooms
- Aluminum Frame
- Available with 4, 6 or 8 wheels
- Easily Rides on Your Truck
- Ships UPS

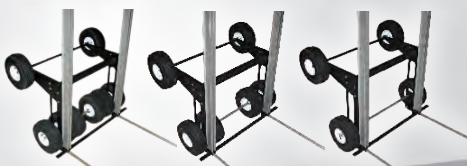

Patented

**DA**  
Deal Assoc. Inc.

Toll Free: **866.599.3325**  
**www.DealAssoc.com**

## THE SEPTIC TANK AGITATOR



### IS YOUR BACK TIRED OF BACKFLUSHING?

We believe agitation save aggravation. Try it and you'll see. The Crust Buster saves you Time and Money

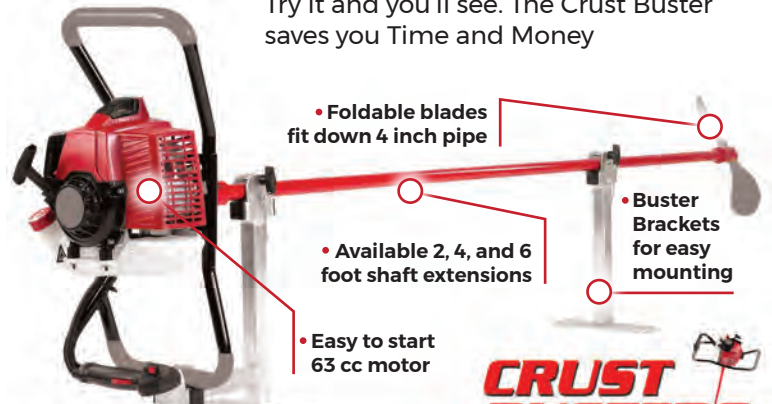

• Foldable blades fit down 4 inch pipe

• Available 2, 4, and 6 foot shaft extensions

• Easy to start 63 cc motor

• Buster Brackets for easy mounting

763-878-2296 | sales@crustbusters.com

**CRUST BUSTERS**

Enjoy **FREE SHIPPING** On All Orders! (To lower 48 states)

- Order Online -

**www.CrustBusters.com**





# ➤ T.E. Price Septic & Excavating

Wayne, Ohio



51 Stone Road, Lindenwold, NJ 08021

**Order Discounted Pumps Online**  
24 hours a day 7 days a week

[www.vacuumsalesinc.com](http://www.vacuumsalesinc.com)  
parts@vacuumsalesinc.com



*We Service  
What We Sell*

VISA Discover PayPal 800-547-7790 • fax: 856-627-3044

**B**evin and Nancy Aurand added this custom purple 2012 Kenworth W900 built out by Morocco Welding with a 4,600-gallon steel tank and Masport HXL 400 pump. The truck is powered by a Cummins ISX 550 hp engine tied to an Eaton Fuller 18-speed transmission. Features include dual 3-inch inlets (front and back) and a 4-inch dump valve, heated collars, a Garnet SeeLevel gauge, LED side and rear work lights and strobe safety lights all around. The interior includes leather air-ride seats, Sirius XM radio with Bluetooth, AC, minimizer floor mats and power windows. Graphics were provided by Image360. Zach Aurand is the driver and the rig is used for commercial and residential pumping. **P**

SHOW US **YOUR** CLASSY TRUCK!

**Got a truck with real WOW appeal?  
Show it off to Pumper readers!**

Send photos of your vacuum truck after it has been lettered with your company name. Please limit your submission to one truck only.

Your Classy Truck submission must include your name, company name, mailing address, phone number, and details about the truck, including tank size, cab/chassis information, pump information, the company that built the truck, and any other details you consider important. In particular, tell us what features of the truck help make your work life more efficient and more profitable. Email your materials to [editor@pumper.com](mailto:editor@pumper.com) or mail to Editor, *Pumper*, P.O. Box 220, Three Lakes, WI 54562.

**We look forward to hearing from you!**



# Innovative Portable Restroom Solutions™

## NEW TRAILER STYLE

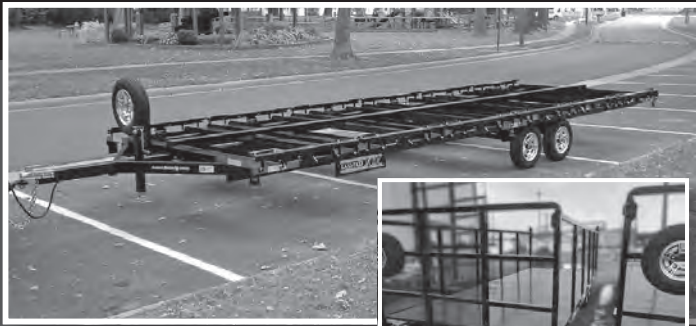

## NEW FLAT BED TRAILER

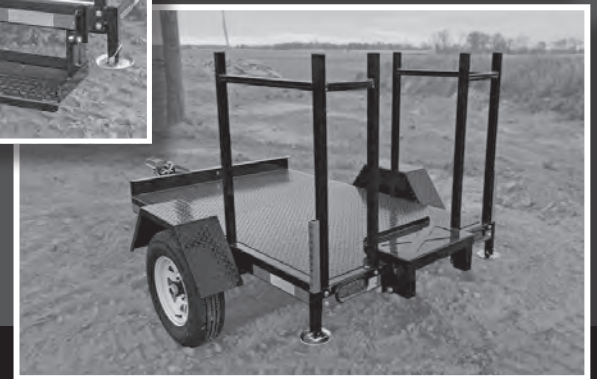

- All trailers will handle from 8 to 26 units
- LaxiTaxi with locking system, requires no straps
- Flat bed trailers have D-rings every 4 ft
- Heavy-duty header
- All axles have torsion bars
- Low profile tires are standard, but we can use any size tire
- 2700 to 3500 torsion bar axles
- LED lights on all units
- Flat bed trailers have diamond plate decks
- Many options available

- Hand rails
- Step can be flipped up when being transported
- Strong and durable diamond plated fenders
- LED lights
- Available in single and double trailers
- This trailer is built strong and built to last

## LOOK FOR THESE OTHER AVAILABLE PRODUCTS

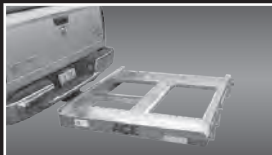

**F.M. Manufacturing, Inc.**  
p 877.889.2246 [www.fmmfg.com](http://www.fmmfg.com)

F.M. Manufacturing, Inc. specializes in Innovative Portable Restroom Solutions™ like trailers, carts and hitch haulers that are designed to help your business be more efficient and more profitable.

**Get new content right to your inbox!**



[www.Pumper.com/alerts](http://www.Pumper.com/alerts)



Wilson, North Carolina  
252-206-1641  
[www.integrity-tank.com](http://www.integrity-tank.com)

**Backed by more than 85 years of combined experience in custom tank building**



### Custom builds include:

- Septic/ Grease/ Industrial Waste
- 200 - 6000 Gallons
- Portable Restroom Service Trucks
- Aluminum/Steel/Stainless

### Additional Services:

- Vacuum pump repairs, conversions, and refurbis

*Integrity Tank where quality and service exceed expectations*

**CONTACT CHAD DAVIS for QUOTES at 252-450-9168**





**YOUR SOURCE  
FOR REAL LEARNING**  
**NAWT**  
National Association of Wastewater Technicians

## Upcoming Training & Events

### Septic System Design

#### NAWT Installer by CPOW

October 14, 2022

Location: Virtual Online Course  
Contact: Lisa Nicoll cpow@cpow.net

#### UA Introduction to Design of Onsite Wastewater Systems

November 7-8, 2022

Location: Maricopa, AZ  
Contact: Kitt Farrell-Poe, kittfp@email.arizona.edu

#### UA Advanced Design of Onsite Wastewater Systems

November 9, 2022

Location: Maricopa, AZ  
Contact: Kitt Farrell-Poe, kittfp@email.arizona.edu

### Inspector Training

#### NAWT Inspection Certification Course by OOWA

October 17, 2022

Location: Muskogee, OK  
Register: oowaok.org

Online NAWT DOT CDL Pre and Post Trip Inspection Course

Please visit  
[NAWT.ORG/TRAINING.HTML](http://NAWT.ORG/TRAINING.HTML)  
to register.

#### NAWT Inspection Certification Course by CPOW

November 17-18, 2022

Location: Virtual Online Course  
Register: www.cpow.net

#### NAWT Inspector by RETS

December 9-10, 2022

Location: San Marcos, TX  
Contact: Lauren Trujillo rets@rets-llc.com

### Operation and Maintenance Training

#### NAWT O&M 2 by CPOW

November 8-9, 2022

Location: Virtual Course  
Contact: Lisa Nicoll cpow@cpow.net

#### NAWT O&M 2 by CPOW

December 5-6, 2022

Location: Virtual Online Course  
Contact: Lisa Nicoll cpow@cpow.net

#### 2022 Mega-Conference

University Plaza Hotel, Springfield, MO  
Oct. 30 - Nov. 2, 2022

For more info: [www.nowra.org/conference/mega-conference](http://www.nowra.org/conference/mega-conference)

Online Vacuum Truck Training Available!

Please visit our website for more information.

**YOUR SOURCE  
FOR REAL  
LEARNING**

For more information call:

**800-236-6298**

**WWW.NAWT.ORG**

# PUMP DEEPER PUMP FASTER



Power Booster®

HydraBore™

**Pressure Lift Corporation Is Your Source for Strong and Reliable Vacuum & Hydro-Excavation Equipment and Accessories.**

We are proud developers of the **Power Booster** and **HydraBore**, pumps that provide vertical lift with virtually no limits. Our equipment serves professionals across many different industries by reducing loading times, getting on and off every job site much faster while cutting labor expenses and reducing potential back injuries with our Power Booster® and HydraBore™ booster pumps.

**Pump deeper - pump faster at any depth; 500' and greater.**



View our updated Coxreels page: [pressurelift.com/products/coxreels](http://pressurelift.com/products/coxreels)

View our video at [pressurelift.com](http://pressurelift.com) at the bottom of the home page



**MASPORT**  
Cobra Plug and Play  
532 CFM Rotary Vane

Power Booster PATENTED

Authorized Dealer for  
**MASPORT** **COXREELS**



**PressureLift.com**

972-355-0550 | 866-504-6596



## Odor Problems



Septic odors stop with  
**SWEET AIR™**  
FILTERING DEVICE

— THE ORIGINAL —

— TUF-TITE, Inc. —  
**800-382-7009** [www.tuf-tite.com](http://www.tuf-tite.com)





# NO BIG TRUCK/TANK ROLLOVERS

Keep a low profile with the patented water in the flatbed



**Built And Designed  
By PRO's Like You**

Smaller frame trucks allow PRO's to get closer to units for service

Why Buy 2 Trucks when  
**1 TRUCK Does It ALL**

Serves 50-70 units on a service route.  
Eliminates P&D routes. Reduces labor cost, fuel and wear & tear.



585-484-7009 | sales@portalogix.com  
PortaLogix.com



We have the **key** to **your** business

**100% FINANCING.  
NO DOWN PAYMENT.**

**NEW AND USED EQUIPMENT**

- ❖ Programs offer longer terms for older equipment
- ❖ We do start ups
- ❖ Seasonal Payment Programs Available

.....  
Conserve your working capital. Keep existing credit lines intact, and enjoy the security of knowing financing is there when you need it.

We offer loan and leasing plans tailored to individual needs.

.....  
If you are having difficulty getting the Credit you need call Jim Thomas.



**JIM THOMAS  
SINCE 1997**

**Toll-Free 877-333-4539  
JimThomas@KeyCommercial.com**

**KEY COMMERCIAL CORP.**  
Commercial Equipment Financing  
**www.keycommercial.com**

**DAVIDSON TANK**  
Bakersfield, California



- Septic/Grease/Industrial Waste
- 400-5,000 Gallon
- Aluminum/Steel/Stainless

Our Chassis Or Yours • Built To Specs



- Portable Restroom Service Trucks
- Aluminum/Steel/Stainless

661.325.2145 • [www.DavidsonTank.com](http://www.DavidsonTank.com)



# Serving the Industry

 Visit your state and provincial trade associations

## Alabama

Alabama Onsite Wastewater Association  
www.aowainfo.org; 334-396-3434

## Arizona

Arizona Onsite Wastewater Recycling Association  
www.azowra.org; 928-443-0333

## Arkansas

Arkansas Onsite Wastewater Association  
www.arkowa.com

## California

California Onsite Wastewater Association  
www.cowa.org; 530-513-6658

## Colorado

Colorado Professionals in Onsite Wastewater  
www.cpow.net; 720-626-8989

## Connecticut

Connecticut Onsite Wastewater Recycling Association  
www.cowra-online.org  
860-267-1057

## Delaware

Delaware On-Site Wastewater Recycling Association  
www.dowra.org

## Florida

Florida Onsite Wastewater Association  
www.fowaonsite.com  
321-363-1590

## Georgia

Georgia Onsite Wastewater Association  
www.georgiaonsitewastewater.com  
706-407-2552

Georgia F.O.G. Alliance  
www.georgiafog.com

## Idaho

Onsite Wastewater Association of Idaho  
www.owaidaho.org; 208-664-2133

## Illinois

Onsite Wastewater Professionals of Illinois  
www.owpi.org

## Indiana

Indiana Onsite Waste Water Professionals Association  
www.iowpa.org; 317-965-1859

## Iowa

Iowa Onsite Waste Water Association  
www.iowwa.com; 515-225-1051

## Kansas

Kansas Small Flows Association  
www.ksfa.org; 913-594-1472

## Kentucky

Kentucky Onsite Wastewater Association  
www.kentuckyonsite.org  
855-818-5692

## Maine

Maine Association of Site Evaluators  
www.maine.com

Maine Association of Professional Soil Scientists  
www.mapss.org

## Maryland

Maryland Onsite Wastewater Professionals Association  
www.mowpa.org; 443-570-2029

## Michigan

Michigan Onsite Wastewater Recycling Association  
www.mowra.org

Michigan Septic Tank Association  
www.msta.biz; 989-808-8648

## Minnesota

Minnesota Onsite Wastewater Association  
www.mowa-mn.com; 888-810-4178

## Mississippi

Mississippi Pumpers Association  
www.mspumpersassociation.com  
601-249-2066

## Missouri

Missouri Smallflows Organization  
www.mosmallflows.org  
417-631-4027

## Nebraska

Nebraska On-site Waste Water Association  
www.nowwa.org; 402-476-0162

## New England

Yankee Onsite Wastewater Association (Massachusetts, Connecticut, Maine, New Hampshire, Rhode Island and Vermont)  
www.yankeeonsite.org; 781-939-5710

## New Hampshire

New Hampshire Association of Septage Haulers  
www.nhash.com; 603-831-8670

Granite State Onsite Wastewater Association  
www.gsdia.org; 603-228-1231

## New Mexico

Professional Onsite Wastewater Reuse Association of New Mexico  
www.powranm.org; 505-989-7676

## New York

Long Island Liquid Waste Association, Inc.  
www.lilwa.org; 631-585-0448

## North Carolina

North Carolina Septic Tank Association  
www.ncsta.net; 336-416-3564

## North Dakota

North Dakota Onsite Wastewater Recycling Association  
701-650-8792

## Ohio

Ohio Onsite Wastewater Association  
www.ohioonsite.org; 740-828-3000

## Oklahoma

Oklahoma Onsite Wastewater Association  
918-727-7113

## Oregon

Oregon Onsite Wastewater Association  
www.o2wa.org; 541-389-6692

## Pennsylvania

Pennsylvania Association of Sewage Enforcement Officers  
www.pa-seo.org; 717-761-8648

Pennsylvania Onsite Wastewater Recycling Association  
www.powra.org

Pennsylvania Septage Management Association  
www.pasma.net; 717-763-7762

## Tennessee

Tennessee Onsite Wastewater Association  
www.tnonsite.org.

## Texas

Texas On-Site Wastewater Association  
www.txowa.org; 409-718-0645

Education 4 Onsite Wastewater Management  
www.e4owm.com; 713-774-6694

## Virginia

Virginia Onsite Wastewater Recycling Association  
www.vowra.org; 540-377-9830

## Washington

Washington On-Site Sewage Association  
www.wossa.org; 253-770-6594

## Wisconsin

Wisconsin Onsite Water Recycling Association  
www.wowra.com; 888-782-6815

Wisconsin Liquid Waste Carriers Association  
www.wlwa.com; 888-782-6815

## NATIONAL

Water Environment Federation  
www.wef.org; 800-666-0206

National Onsite Wastewater Recycling Association  
www.nowra.org; 978-496-1800

National Association of Wastewater Technicians  
www.nawt.org; 800-236-6298

## CANADA

### Alberta

Alberta Onsite Wastewater Management Association  
www.aowma.com; 877-489-7471

### British Columbia

WCOWMA Onsite Wastewater Management of B.C.  
www.wcowma-bc.com  
877-489-7471

British Columbia Onsite Sewage Association

www.bcossa.org; 778-432-2120

### Manitoba

Manitoba Onsite Wastewater Management Association  
www.mowma.org; 877-489-7471

Onsite Wastewater Systems Installers of Manitoba, Inc.  
www.owsim.com; 204-771-0455

### New Brunswick

New Brunswick Association of Onsite Wastewater Professionals  
www.nbaowp.ca; 506-455-5477

### Nova Scotia

Waste Water Nova Scotia  
www.wwns.ca; 902-246-2131

### Ontario

Ontario Onsite Wastewater Association  
www.oowa.org; 855-905-6692

Ontario Association of Sewage Industry Services  
www.oasisonario.on.ca  
877-202-0082

### Saskatchewan

Saskatchewan Onsite Wastewater Management Association  
www.sowma.ca; 877-489-7471

### Canadian Regional

Western Canada Onsite Wastewater Management Association  
www.wcowma.com; 877-489-7471



THE FUTURE OF INDUSTRIAL PUMPS BROUGHT TO YOU BY



**ANNOVI REVERBERI**  
The Power of Experience

**RTD**



**Industrial**

140° F - Max Water Temp  
1 1/2" - Inlet Thread  
1" - Discharge Thread  
110 oz - Oil Capacity

**RTD 1000 RPM N VERSION SOLID SHAFT 35MM**

MODEL	MAX GPM	MAX L/MIN	MAX PSI	MAX BAR	POWER EBHP	BORE DIA MM	STROKE MM	CRANKSHAFT ID STAMP	WEIGHT LBS.
RTD80-300	21.0	79.5	4350	300	65.0	32	42	4	128
RTD100-200	25.0	94.6	2900	200	49.8	32	42	3	128
RTD100-200SX	25.0	94.6	2900	200	49.8	32	42	3	128
RTD130-160	32.0	121.1	2300	160	50.5	36	42	3	128
RTD130-200H	34.5	115.0	2900	200	68.0	36	42	3	128
RTD160-130	40.0	151.4	1850	130	50.8	40	42	3	128

SX - 180° Rotated Shaft Configuration  
H - Nickel Plated

**RTX**



**Industrial**

140° F - Max Water Temp  
1" - Inlet Thread  
1 1/2" - Discharge Thread  
76 oz - Oil Capacity

**RTD 1450 RPM N VERSION 30 x 80MM SOLID SHAFT**

MODEL	MAX GPM	MAX L/MIN	MAX PSI	MAX BAR	POWER EBHP	BORE DIA MM	STROKE MM	CRANKSHAFT ID STAMP	WEIGHT LBS.
RTX30	8.0	30.3	4350	300	23.9	20	23	3	72
RTX50	12.0	45.4	4350	300	35.8	25	23	3	72
RTX60	14.0	53.0	4350	300	41.8	25	28	1	72
RTX70	17.0	64.4	3000	200	33.8	30	23	3	72
RTX85	21.0	85.0	2200	200	31.7	30	28	1	72
RTX-HW85.150N*	21.0	85.0	2200	200	31.7	36	23	1	72
RTX100	24.0	90.8	1800	124	29.8	36	23	3	72
RTX150	39.6	150	1450	100	36.2	40	28	1	72

\*HW - includes Hot Water Kit



**WORKING WELL UNDER PRESSURE**

Pressure Washers & Drain Jetting Equipment

**NEW**



**RCJ4008H**

»8 gpm @ 4000 psi  
»800 cc EFI  
Honda Engine

**Call for Quote**

**NEW**



**LJ4008H**

»8 gpm @ 4000 psi  
»800 cc EFI  
Honda Engine

(NARROW DESIGN)

**Call for Quote**

**NEW**



**4008H Power Unit**

»8 gpm @ 4000 psi  
»800 cc EFI  
Honda Engine

Just Add A Tank!

**Call for Quote**

**3012H Power Unit**

»12 gpm @ 3000 psi  
»800 cc EFI  
Honda Engine

**Call for Quote**

**3012H Compact Skid**

»12 gpm @ 3000 psi  
»800 cc EFI  
Honda Engine

(100 GALLON TANK)

**Call for Quote**

**4008H Compact Skid**

»8 gpm @ 4000 psi  
»800 cc EFI  
Honda Engine

(100 GALLON TANK)

**Call for Quote**

**NEW**



**VM4008H**

»8 gpm @ 4000 psi  
»690 cc  
Honda Engine  
»50' x 3/8" Washdown  
Hose on DC Reel

**Call for Quote**

**STB3012H**

»12 gpm @ 3000 psi  
»800 cc EFI  
Honda Engine  
»400' x 1/2" Jet Hose on  
DC Reel

**Call for Quote**

**TT4 SERIES**

»18 gpm @ 4000 psi  
»74 HP Turbo Intercooled  
HATZ Engine  
»500' x 1/2" Jet Hose/  
Hydraulic Reel

**Call for Quote**

\*\*\* All Jets Shown Come with Pulse Valve, 2 Jet Nozzles, Tool Box, Gloves, Safety Glasses, \*\*\*  
Tip Cleaner, Tiger Tail, Wash Down Trigger Gun with Nozzles.

**Building Drain and Sewer Equipment since 1981.**

We Build Electric, Gas and Diesel powered models up to 4000 psi, flows up to 40 gallons per minute. Don't see exactly what you want...

We will custom build exactly what you want!

800-648-5011 | [www.camspray.com](http://www.camspray.com) | [sales@camspray.com](mailto:sales@camspray.com)

**AR NORTH AMERICA**  
When Quality Matters  
[www.arnorthamerica.com](http://www.arnorthamerica.com)  
763-398-2008

For More Information Contact

Thom Calvin  
(763) 398-7564  
[thomasc@arnorthamerica.com](mailto:thomasc@arnorthamerica.com)

Randy Rowan  
(768) 999-5405  
[randyr@arnorthamerica.com](mailto:randyr@arnorthamerica.com)





Jim Anderson, Ph.D.  
Contributor

Jim Anderson, Ph.D., is an emeritus professor at the University of Minnesota Department of Soil, Water and Climate. He works with the National Association of Wastewater Technicians and is a recipient of the pumping industry's Ralph Macchio Lifetime Achievement Award. Send Anderson questions about septic system maintenance and operation by email to editor@pumper.com.

# Monitoring and Sampling Are Always Good Ideas

Assuming a septic system is working properly could put human health and the environment at risk

By Jim Anderson, Ph.D.

As our onsite systems have become complex with more treatment components, the need to regularly monitor performance has increased. Additional pretreatment components, ATUs and media filters all require increased maintenance to ensure performance.

Using more advanced treatment technologies than conventional septic tank-to-soil treatment has allowed systems to be installed in more sensitive environmental areas. Monitoring system performance in these areas is an integral part of protecting the environment and public health. Without systematic monitoring and sampling, the manufacturers, owners nor the environmental agencies know whether the system is performing to the required standard.

As service providers, you already know that many of the advanced treatment systems manufacturers require some type of training course or certification to install or work on their systems. These manufacturers have their own set of monitoring, maintenance and sampling programs. It is important these protocols are followed explicitly because not doing so usually voids any warranty of the system.

## WHAT TO TEST

What needs to be monitored and sampled and the frequency of those activities depends on manufacturers requirements, system location, the environmental or health risk involved, and permitting authority requirements. This applies to all systems where there is an interest in determining if the system is working the way it should.

A less complex example of a regular performance check is the requirement in lakeshore areas to have the septic tank drainfield system checked on a regular schedule. For my own system, the county requires an inspection every three years. The septic tank is accessed through the manhole, sludge and scum levels are measured, and if the total thickness of these layers exceeds one-third the operating depth, the tank is cleaned. The inspection also requires the service provider to inspect the drainfield area for any evidence of effluent at the surface. If surfacing is detected, the homeowner needs to work with an installer to repair or replace the system.

For other types of systems, sampling and monitoring frequency depends on what constituents need to be determined and what the reason for the requirement is. An example is restaurant systems where it is important when effluent to the soil treatment area is lower than 170 mg/L biochemical oxygen demand, 60 mg/L total suspended solids and 20 mg/L fats, oils and grease.

➤ I have often advocated for always measuring flows, even in residential systems. ... It can confirm whether a system is hydraulically overloaded and solutions identified as to whether flow can be reduced or the system has to be enlarged.

A sampling and observation schedule is put into place to determine whether these levels are accomplished by a series of septic tanks or additional pretreatment by an aerobic treatment unit or media filter. Following installation of the units, the sampling schedule should begin with frequent observations, then lengthening time in between until the long-term sampling and monitoring frequency are established.

## FIVE-PHASE SAMPING

An example five-phase sampling approach would be starting two weeks after system installation, or startup sampling would begin on a weekly basis. If the samples are meeting the required levels after two months, sampling would move to phase two — every other week for two months. After four passing samples, phase three would entail a sample once a month for three months. If the samples pass, a sample would be taken quarterly for a year as phase four. If every sample passes, then the long-term sampling period would go into effect as either annual or semiannual samples throughout the life of the system.

An approach like this provides data on how the system performs from startup through typical operation. It will detect operation differences during different seasons or time periods. System maintenance schedules can be adjusted depending on what the sample data show. With periods of high use or differences due to seasonal temperatures those can be identified and changes in operation can be made.

In environmentally sensitive areas or when an experimental system is installed, additional wastewater constituents such as nitrogen, phosphorus or bacteria may require monitoring. Examples are in areas where there are elevated nitrate levels in the groundwater or where freshwater estuaries on the coast need to be protected. Phosphorus would be sampled along lakeshores





- George, VP of Sales 954-558-0816
- Roger, Regional Sales Manager 305-409-8603
- RJ, Inside Sales & Parts Manager 786-328-9330

**72 Years In Business!**

**6 In Production**



2024 Mack MD7, 300 hp, Cummins, Allison auto, chrome bumper and grille, 2500 alum. tank, Fruitland RCF 500, diff locks, air ride rears. **Call For Price**

**Aluminum,  
Stainless Steel,  
Carbon Steel  
Tanks of  
All Sizes  
Available.**

**6 In Production**



2024 Mack MD7, 300 hp, Cummins, Allison auto, chrome bumper and grille, 2500 CS tank, Masport Titan 407 cfm, diff locks, air ride rear. **Call For Price**

**In Production**



2023 Mack Granite, MP8 455 HP. Auto Allison trans. 66K GVWR, 4200/200 alum tank, 36" box, NVE blower 530 cfm, hydraulic drive, toolbox, jetter 10 GPM @ 3000 PSI. **\$249K**

**Many Different  
Make & Model  
Chassis  
Available.**

**In Production**



2023 Peterbilt 389 extended cab, Cummins ISX 455 HP. Auto Allison trans. 66K GVWR, 4200 alum tank, 36" box, NVE blower 530 cfm. **\$277K**

**In Stock**



Steel and Alum Tanks, 2500 to 4200 available for immediate delivery. **Call For Price**

**In Production**



2023 Peterbilt 389, MX-13 510 hp, auto, tri axle, 79K GVWR, air ride, NVE blower, 5000 alum. tank. **\$292K**

**10 In Production**



2023 Mack Granite, MP8 455 HP. Auto Allison trans. 66K GVWR. 4000 CS tank. **\$209K**

or river shoreline to reduce potential for seasonal algal blooms. Fecal coliform bacteria as indicators of potential pathogens would be sampled in areas of rapidly permeable soils or reduced ability to provide adequate separation distance to groundwater.

**ADDED SAMPLING**

Dissolved oxygen, pH and wastewater flow are additional constituents or characteristics that can be monitored and sampled, which can provide information on whether a system component is operating as intended. An example where DO is important to monitor is for an ATU. To provide oxygen to break down the organic matter in waste, the DO should be higher than 1 mg/L. A reading of less than 1 mg/L indicates a problem that should be investigated.

I have often advocated for always measuring flows, even in residential systems. It is a key component to the performance of any system. Having flow data when troubleshooting a system is essential and relatively easy to obtain with a water meter. It can confirm whether a system is hydraulically overloaded and solutions identified as to whether flow can be reduced or the system has to be enlarged. Research has shown systems operating on average at 80% or more of their design flow are likely to experience problems, so having that information can avoid problems before they arise.

Monitoring and sampling should be a part of our regular system maintenance schedules to ensure systems are operating the way they should to protect the environment and human health. **P**





# Portable Sanitation

By Craig Mandli



## DECALS/MAGNETS/LABELS

### Allied Graphics decals

Decals from **Allied Graphics** are designed for the portable restroom industry to stick and stay on units and in tough environments. The long-life vinyl decals use ultraviolet inks

to look good for years, according to the maker. The decals can also be applied to sinks and trailers. **763-428-8365; www.allied-graphics.com**

### Roeda decals

**Roeda** decals utilize 4 mil permanent adhesive vinyl and UV fade-resistant inks for applications such as portable restrooms, restroom trailers, hand sanitizer stands and outdoor sinks. They come in a variety of stock UV inks, but can also be printed with any custom Pantone match. Decals can be cut to any size or shape. A UV clearcoat or lamination adds extra protection against the elements. Options and adhesives are available using existing logos or having new designs made. **800-829-3021; www.roeda.com**



## GRAFFITI REMOVAL

### Safe-T-Fresh by Satellite Industries Graffix

**Graffix** from **Safe-T-Fresh** by **Satellite Industries** is an environmentally safe liquid gel used to remove paint and chemical-resistant coatings and does not contain MEK or other harsh, flammable chemicals. It is designed to remove multiple layers of oil and latex paints from various substrates, including HDPE, wood, brick, stone or metal. The gel is formulated to adhere to vertical surfaces without running. It contains no water

and is intended to be used undiluted. Spray it on the surface to be treated, allowing a minute for the formula to activate. For best results, wipe it off with the provided sponge. A rough towel or rag is also acceptable. Deep penetrations of ink or paint may require a second application. In that case, apply it and allow the gel to soak an additional 2 to 4 minutes. Wipe it with a sponge and rinse if necessary. **800-883-1123; www.satelliteindustries.com**



## ODOR CONTROL

### Century Chemical Toi-De-Fresh

The **Toi-De-Fresh** line of portable sanitation products from **Century Chemical** is available in Super Concentrated and Premixed formulas in both formaldehyde and nonformaldehyde variations. A variety of in-stock fragrances are available, in addition to standard offerings such as grape, piña colada and vanilla. The recently reformulated 2-ounce baby powder fragrance toss-in packet provides strength, longevity and odor control. The items can be paired with Super Mask masking agent and the company's line of all-purpose cleaners and citrus degreasers. **800-348-3505; www.centurychemical.com**



### J&J Portable Sanitation Products Truex Power Packets

**Truex Power Packets** from **J&J Portable Sanitation Products** are a nonformaldehyde, water-soluble, portion-control deodorizer using multiple odor control components that engage when needed. The formula utilizes advanced fragrance and long-lasting, deep-blue, non-staining color. They work to continuously break

down paper and waste, reducing mounding for increased odor control in the holding tank to provide long-lasting protection in the most demanding environments. They are available in a variety of exclusive fragrances and sizes. **800-345-3303; www.jjchem.com**

### Surco Portable Sanitation Products Potty Fresh Summer Plus

**Potty Fresh Summer Plus** portable restroom deodorant from **Surco Portable Sanitation Products** is designed to replace formaldehyde deodorants used in heat and humidity. It has two biocides, neither of which is formaldehyde, so it is eco-friendly and safe to use. It has a strong fragrance and deep blue nonstaining dye. Metazene neutralizes odor molecules in portable restroom tanks and ambient air. A choice of powerful fragrances freshens the surrounding air, minimizing customer complaints and callbacks. The non-staining dye hides waste, paper and debris. **800-556-0111; www.surco.com**



### Walex Products Porta-Pak Max

**Porta-Pak Max** from **Walex Products** contains 50% more color, 50% more odor control, and double the fragrance of the original Porta-Pak. It is ideal for hot conditions, heavy traffic or any time a product is needed that's a step above the usual deodorizer. It is formaldehyde-free, biodegradable and contains nonstaining dye. Drop one packet into the bowl for weeklong odor control. **800-338-3155; www.walex.com**

(continued)



# Roots™ Vacuum Blowers

World leader in blower technology for mobile vacuum applications



Introducing the EasyAir™ Mobile Vacuum Package (MVP), capable of providing both vacuum for product loading and pressure for product offloading through an integrated 4-way valve.

- Compact size and noise reduction technology for mobile applications
- Widest and most complete range of blowers for the toughest challenges
- With models capable of pressure up to 6,515 CFM and vacuum up to 28" Hg
- Made in the USA

For more information contact:

t: 1-800-55-ROOTS (76687)  
 e: inquiries.USA@howden.com  
 w: www.howden.com



Trinado

RAM

MVP

RCS/RCS-J/RAS-J

RAM-J

Revolving Around You™

© Howden Group Ltd. All rights reserved. 2021



## DEWATERING - IT'S A PIECE OF CAKE!

Let ParkProcess supply you with the most economical solutions for dewatering septage and grease trap waste. Choose from a wide range of models and sizes for the right equipment to meet your needs.



BIG TIPPER



THE BIG ROLLING TIPPER



POLYCAT



SLUDGE KING

855.511.PARK  
 www.ParkProcess.com



PORTABLE RESTROOM TRUCKS  
 SLIDE IN UNITS  
 SEPTIC TRUCKS

Backed By a History of Reliable Service, Innovation & Care

TRUCKS  
 BUILT  
 FOR  
 DEMANDING  
 JOBS  
 JUST  
 LIKE  
 YOURS



Look to us for the toughest septic trucks, portable restroom trucks, hydrovac units and slide-in units. Crafting any truck to your needs.

- Specialized & Customized Septic Trucks
- Portable Restroom Trucks Built for Your Specific Needs
- Slide In Units: Affordable Back-up or Starter Tanks That Are Tough & Compact

CONTACT TIM COUNTS 254-721-5675 or BRUCE CURRY 254-760-1514  
 — www.atcvacuumtruck.com —





## PORTABLE RESTROOMS

### PolyJohn PJN3

The **PJN3** from **PolyJohn** has a spacious interior and a translucent roof. It features anti-slip floors, maximum ventilation, a two-roll paper dispenser and an occupancy signal latch. Options include a hand-washing sink or hand-sanitizing dispenser, convenience shelf with hook, locking kit and gender signs. It is available in the standard static tank model or with an optional recirculating flush tank. Its waste tank design makes cleaning and servicing easy, according to the maker. Each unit comes with a door-mounted mirror, handle and a nonsplash urinal. It is made from high-grade polyethylene. **800-292-1305; www.polyjohn.com**



### Sansom Industries Zenith

The **Zenith** portable restroom from **Sansom Industries** has an 80-gallon holding tank with deep sump, blow-molded construction, a roomy interior with ample headroom, smooth interior surfaces for easy cleaning, stainless steel fasteners, a three-roll paper holder and attractive aesthetics, according to the manufacturer. Many custom options are available. **844-972-6766; www.sansomindustries.com**

## PORTABLE RESTROOM MOVERS

### Armal transport dolly

The **Armal** transport dolly can be used to move any Wave standard portable restroom. It is made of lightweight aluminum and is compact, making it easy for one operator to maneuver a restroom quickly. It is designed for rigorous daily use and speeds the process of picking up and/or dropping off portable restrooms safely and efficiently. **770-491-6410; www.armal.biz**



### Deal Assoc. Super Mongo Mover

The **Super Mongo Mover** hand truck from **Deal Assoc.** easily tips back and moves portable restrooms, and can carry full-size ADA handicap restrooms. The tall frame provides leverage so even smaller service technicians can move restrooms safely and easily. The alloy aluminum and steel frame is lightweight and strong, and only anodized aluminum touches the restroom body to prevent rust-staining. It is available with four, six or eight wheels with either pneumatic or flat-free foam tires. **336-599-3325; www.dealassoc.com**

It is available with four, six or eight wheels with either pneumatic or flat-free foam tires. **336-599-3325; www.dealassoc.com**

## PORTABLE SINK

### T.S.F. Tuff-Jon 90-gallon free-standing sink

The **Tuff-Jon** 90-gallon free-standing sink with trash container from **T.S.F.** provides two wash stations; hands-free, foot-operated pumps; a towel dispenser; and a 10-cup-capacity soap dispenser. A lifting bracket allows for easy positioning in high-rise applications. The lifting bracket has a 1/4-inch wire cable, weighs 30 pounds and is safety orange. The unit is constructed from easy-to-clean polyethylene, with 45-gallon waste and freshwater capacities, a towel dispenser, trash container, protective skid plate and freshwater drain plug. It weighs 85 pounds. **800-843-9286; www.tuff-jon.com**



## RESTROOM/Shower TRAILERS



### A Restroom Trailer Co. (ART Co.) 1404-W

The **1404-W** restroom trailer from **ART Co.** is designed for fast and easy setup with a streamlined appearance. The 14-by-8-foot, four-station unit comes with foldout steps and stabilizer scissor jacks. Units are available in Embassy, Cellar, Estate and

Chalet interior finishes and in several exterior color combinations to match existing fleets. Standard features include a 535-gallon waste tank, 200-gallon freshwater tank, heavy-duty steel frame, integral trailer skirting, 2 5/16-inch adjustable trailer hitch, heavy-duty tongue jack, maple cabinetry, Corian countertops, LED lighting, and ducted heat and air conditioning. Options include flip-up steps, AM/FM/MP3 stereo and pipe-mount leveling jacks. **269-435-4278; www.arestroomtrailer.com**

### Ameri-Can Engineering shower trailers

Shower trailers from **Ameri-Can Engineering** are available in 15 models, including handicapped accessible and ADA compliant. Shower/restroom combination trailers and decontamination shower trailers are also available. Each trailer is designed for rugged long-term use and to accommodate large numbers of users with comfort and cleanliness. The trailers are easy to set up and service and are user-friendly, according to the maker. Shower trailers are available in many sizes, colors and floor plans. All trailers have an extra-large steel, epoxy-lined waste tank; Torflex axles; a lockable equipment room; onboard poly freshwater tank; and on-demand propane hot-water heater. **574-892-5151; www.ameri-can.com**



### Comforts of Home Services ADA line

The ADA-accessible line of restroom, shower and combination trailers from **Comforts of Home Services** is in full compliance with federal guidelines for the interior of the trailer.

(continued)



# software made **simple**

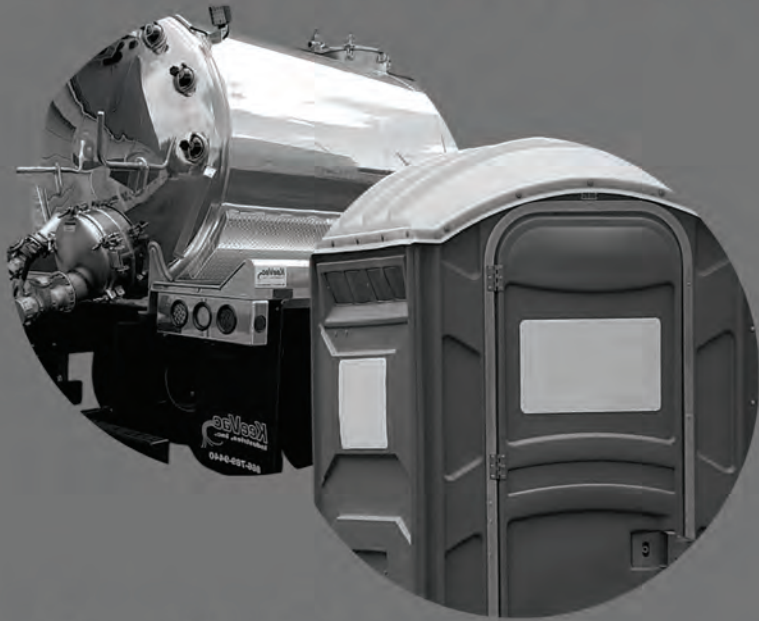

ServiceCore is built for your liquid waste and roll-off business to help you get your **jobs done, get paid, and provide better service to your customers.**

**SERVICECORE**

(855) 980-6669

[lp.servicecore.com/cole](http://lp.servicecore.com/cole)



## We Make Portable Sanitation Smell Good!

AVIATION • WASTEWATER • CHARTER BUS  
SEPTIC MAINTENANCE • RV • MARINE



Proudly making quality, safe sanitation possible since 1926.

[www.centurychemical.com](http://www.centurychemical.com)



**Bio-Tab**

**Toi-De Fresh**



- RESTROOM TRAILERS
- SHOWER TRAILERS
- LAUNDRY TRAILERS



[LangRestroomTrailers.com](http://LangRestroomTrailers.com)  
724.972.6590



Access options include a standalone, commercial aluminum ramp system. The trailer is lowered using electric, one-button execution for 20-foot and smaller models. Trailers longer than 20 feet have an ADA lowering module with attached aluminum ramp. The hydraulic lowering system is designed for customers renting the trailer or moving the trailer numerous times at the same venue. It takes less than 15 minutes to lower the ADA module and then lower the aluminum ramp. **630-906-8002; www.cohsi.com**

**DRE Custom Trailers four-station trailer**

**DRE Custom Trailers** offers a 12-foot, four-station restroom trailer with steel frame construction and a smooth-side aluminum exterior skin. It has a 7,000-pound suspension and aluminum wheels, with a one-piece fiberglass roof, adjustable-height hitch and a 110/12-volt converter system. Its control panel controls the power unit, radio, lights, water pumps and AC. It is designed for very low floor height, with one-step entry, LED lights throughout, power vents, a backup water pump and easy access to the mechanical room. It comes with a 275-gallon waste tank and 150-gallon freshwater tank. Options include a cold-weather package and interior murals. **704-633-6098; www.drecustomtrailers.com**



**JAG Mobile Solutions Smart Shower**

The **Smart Shower** from **JAG Mobile Solutions** is a compact eight-stall shower trailer. A 9,900-pound GVWR provides mobilization safety. A Class A commercial driver's license is often

not required to transport the unit, depending on local regulations. A compact profile compared to some traditional trailers allows more units to be placed in a tighter area when serving special events or responding to emergencies. **800-815-2557; www.jagmobilesolutions.com**

**Lang Specialty Trailers ADA trailers**

**ADA trailers** from **Lang Specialty Trailers** offer a balanced blend of ADA requirements and luxury features. Manufactured efficiently to meet the Americans with Disabilities Act, these trailers also check the boxes of comfort and pleasing aesthetics. They provide exceptional ramp utility that requires no tools for installation, allowing for ease of access to the trailer cabin. Each trailer offers first-rate metered faucets, waterless urinals and A/C units to ensure optimal comfort within the unit. The interior and exterior lighting is efficient and inviting, providing a stunning illumination to the cabin, according to the maker. **724-972-6590; www.langrestroomtrailers.com**



**NuConcepts-Very Impressive Portables Majestic**

The **Majestic** solar-powered and self-contained restroom trailer from **NuConcepts-Very Impressive Portables** is available in two- or four-

unit configurations. Common sealed roto-cast holding tanks help make servicing easy. Using high-grade, computer numerical control-cut fiberglass panels and wood-free-floor construction, the luxury restroom trailer is built for ease of maintenance and durability, according to the maker. It has arched doorways, curved countertops, flushing porcelain toilets, brushed aluminum ceilings, recessed LED ceiling lighting, beveled glass mirror and plank flooring in each spacious private restroom. **800-334-1065; www.nuconcepts.com**

**Optimus Industries OI-3**

The **OI-3** restroom trailer from **Optimus Industries** sets up quickly utilizing different stabilizer options, and has easy set-up steps stored inside wide entry doors with large grab handles. It has a durable, spacious and easy-to-clean interior with fiberglass walls, solid-surface countertops and composite trim and cabinets. The unit is outfitted with quality commercial fixtures for years of trouble-free operation, according to the maker. The interior features are finished with transit grade flooring for durability. The exterior features seamless fiberglass with a composite backer that will not rot, warp or degrade and is easy to repair. It also includes vacant/occupied indicators. It sits on a 7,000-pound torsion axle along with 16-inch aluminum wheels and radial tires for a smooth ride. **574-226-0691; www.oirestrooms.com**



**Rich Specialty Trailers Neptune Anti-Virus**

The **Neptune Anti-Virus** restroom trailer from **Rich Specialty Trailers** is built with permanent interior walls that kill microbes known to carry viruses. The material is imported from Europe, where it was tested and used in medical applications and proven to be effective at killing viruses, including COVID-19, according to the maker. The anti-microbial forms a colorless and odorless polymer that bonds to treated interior surfaces, forming a protective barrier. The trailer is built using composite materials on the walls, ceiling and floor, making the trailer water-resistant for easier maintenance and cleaning. Men's and women's restrooms come standard, along with three hand-wash sinks on the exterior rear of the trailer, allowing use without entering the restrooms. The sinks use self-closing faucets to save water, and dividers between sinks can also be ordered providing another barrier to reduce the risk of spreading infection. **260-593-2279; www.richrestrooms.com**

(continued)





In It To Win It



**Armal**  
Strong. Experienced. Worldwide.

770-491-7680  
www.armal.biz



**Get FIT** in the right pumper truck!



**2023 Freightliner M2, 4,000-Gallon Alum. Tank, 4310 and 4307 NVEs Available.**

Now taking orders for 2024 model year chassis!



Call **608-438-4816**

See our entire inventory at  
**truckcountry.com**



TRUCK SALES • EXPERT SERVICE • PARTS • FINANCING

**JDC DELIVERS**

JACK DOHENY COMPANY

**Portable Inspection Solutions**

**Vivax vCam 6HD**



**Vivax vCam MX-2 Mini Camera**



**Vivax vLoc3 Cam Locator**  
#12250100001



**enz eBomb 250**  
#40250iB



**MainLite® Portable Inspection Systems**



Offering the full range of portable inspection and locating equipment including push cameras/locators, portable mainline crawler systems and jetting cameras.

Full mainline inspection and cleaning truck mount units to service all your inspection needs.

Providing best in class service and support across 16 locations in the U.S. and Canada  
**800.336.4369 | dohenycompany.com**





## SERVICE VEHICLES

### Crescent Tank vacuum tank

The **Crescent Tank** vacuum tank is flat inside and out. It can carry up to 10 portable restrooms, and the weight capacity is the same as a flatbed truck. It has no baffles, allowing it to be emptied completely to avoid internal corrosion. With the included pump at specified cubic feet per minute, unnecessary structural fatigue is eliminated. It is fabricated from 1/4-inch steel for structural strength. Its workstation is designed for the portable restroom industry. The liftgate rail width allows units to fit, and multiple liftgate decks and rail options are available. Fresh water is held inside the external 1/2-inch-thick poly tank. It can be installed on any chassis within the specifications required for each model based on axle ratings and maximum load capacity. **585-657-4104; www.crescenttank.com**



can be mounted on a variety of chassis and with a variety of pumps. Each unit comes with an upgraded DC-10 washdown pump and hose reel from Hannay Reels. Exterior controls and dual cabinets are designed for operator safety and convenience. An arctic package and safety lighting are available. **866-789-9440; www.keevac.com**

### Pik Rite Flatbed Restroom Hauler

The **Flatbed Restroom Hauler** from **Pik Rite** has a 650-gallon tank, flatbed and liftgate. The tank has a 400-gallon waste compartment and internal 250-gallon freshwater compartment for even weight distribution. The truck includes a National Vacuum Equipment 304 vacuum pump, dual 2-inch fill hoses, 20 gpm washdown system, dual-spring return freshwater hose reels and dual 2-inch bucket fills. A 20-inch top manway, 5-inch sight eyes and clear-hose sight tube are included. The truck is equipped with a 98-by-102-inch aluminum flatbed and Thieman TVL liftgate. Two diamond plate toolboxes are mounted on the passenger side. The truck has an LED running light kit with a durable, fully molded wiring harness. **800-326-9763; www.pikrite.com**



### FMI Truck Sales & Service WorkMate

The **WorkMate** service truck from **FMI Truck Sales & Service** is designed with efficiency and operator comfort in mind, according to the maker. The ergonomically

designed workstation can be operated all from the driver's side of the vehicle and, with over 60 cubic feet of storage space, there's enough room for supplies. The unit can be modified to carry up to six toilets without a trailer. With its compact design, the unit pairs well with Isuzu's maneuverable and fuel efficient N-Series chassis as well as Hino, Ford, Ram, GM or International chassis. The modular design allows for easy replacement of components if repair is needed. **800-927-8750; www.fmitrucks.com**

### PortaLogix service truck



The mid-size **PortaLogix** service truck accommodates waste, water and the ability to carry up to six units. It utilizes a transverse waste tank and freshwater tank that doubles as the truck bed. It can carry 800 gallons of wastewater, 350 gallons of freshwater while transporting standard size restrooms. They feature dual-side service allowing operators to access water drop points on all four corners of the bed. Customers can also choose between two- or a four-wheel drive. Equipment can be permanently stored on the vehicle, making emergency requests quick and efficient to handle. The service trucks can also be driven without a CDL. **585-484-7009; www.portalogix.com**

### Imperial Industries Flatvac

The 1,000-gallon stainless steel **Flatvac** from Imperial Industries can carry up to six portable restrooms. The baffled, internally divided tank offers 700 gallons of waste capacity and 300 gallons of freshwater capacity. In addition, the unit offers dual-side bucket fill, dual Hannay hose reels with 50 feet of hose, a Pumptec X-5 washdown pump, Masport HXL4 plug-and-play vacuum pump system, Thieman liftgate, and a 3-inch stainless steel boom with 30 feet of 2-inch intake hose and a suction nozzle. **800-558-2945; www.imperialind.com**



## SLIDE-IN UNITS

### TankTec slide-in tank

Slide-in tanks from **TankTec** range from 100 to 995 gallons. The tanks are available in single-compartment for grease trap and septic service or two-compartment for portable restroom service. **888-428-6422; www.tanktec.biz**



## TRANSPORT TRAILERS

### KeeVac Industries KV999

The **KV999** from **KeeVac Industries** carries a 999-gallon portable restroom vacuum tank for operators who want to stay under the U.S. Department of Transportation tanker endorsement requirement. It

is available in steel, stainless steel and aluminum, with single- or dual-side service, holds 699 gallons of waste and 300 gallons of freshwater, and includes a two-unit fold-down restroom carrier with trailer hitch. The tank



### F.M. Manufacturing 30-foot trailer

The 30-foot flatbed trailer from **F.M. Manufacturing** has three 3,700-pound torsion bar axles, side roller for easy loading, low-profile tires, solid front header and tie-downs on both sides. The customizable trailer has electric brakes on all axles and LED lights. **877-889-2246; www.fmmfg.com**



**Johnny Mover Trailer Sales trailer**

Portable restroom transport trailers from **Johnny Mover Trailer Sales** have skid-locking, using an iron bar with a chain-binding system to secure multiple units. Models are available to handle six to 20 restrooms, and all feature brakes, paint options, lighting, leaf-spring suspension, front deflectors to protect units from road spray and debris, and optional powder-coating and chrome wheels. **800-498-3000; www.cesspoolcleaners.com**



**Pumper**

Check out more manufacturers and dealers at: **pumper.com**

**SIGN UP**  
for e-newsletters  
**pumper.com**



**Liquid Waste Industries trailer**

Custom-built portable restroom delivery trailers from **Liquid Waste Industries** carry six to 24 restrooms and come with or without sides. They are built with heavy-duty steel and come standard with torsion axles, electric brakes, flush-mounted lights, and 10- or 13-inch wheels and tires. Custom upgrades include gates, leaf-spring axles, fold-down ramps, LED lights and choice of hitch. **877-445-5511; www.lwiinc.com**



**McKee Technologies-Explorer Trailers Transporter**

The **Transporter** from **McKee Technologies - Explorer Trailers** has easy-to-adjust carrier slats that box in any size restroom skid. Multiple-size skids can be configured securely in the same load, providing safe, flexible transportation for many styles of portable restrooms. Models range from 8 to 48 feet, accommodating up to 24 units. All include fully independent suspension axles designed to eliminate side-to-side shock transfer. An optional front wind deflector protects units from road spray, stones and wind loading. Hot-dip galvanizing is available for corrosion protection. **866-457-5425; www.explorertrailers.com P**

**WIRING JUST GOT EASIER**  
SIMPLE. INTUITIVE. SMART.

**ClickTight™**

Choose ClickTight™ from Orenco to connect a control panel, up to four floats, **and a pump.**

With ClickTight, you can ...

- Eliminate splice boxes
- Connect to a broad range of control panels with 60 feet of direct-bury wiring cable
- Attach a wide variety of pumps using a pump adapter
- Save time and money

**Try ClickTight™ Today!**

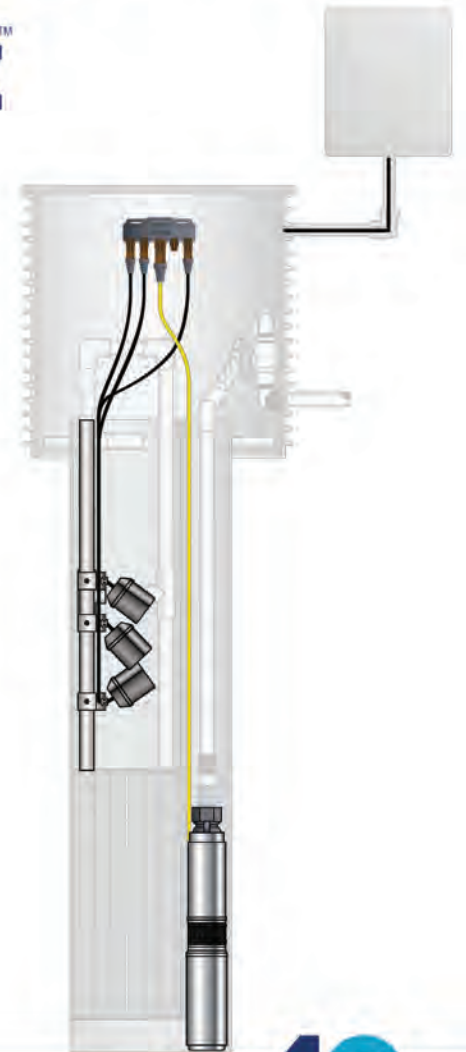

To learn more, contact Orenco at (800) 348-9843, +1 (541) 459-4449, or visit **www.orencosystems.com**.







# TRANSPORT TRUCK SALES, INC.

Ask for Scott – 888-395-7551 After hours call Scott at 816-590-4076

Delivery Available Anywhere in the Lower 48!! [www.TransportTruck.com](http://www.TransportTruck.com)



**2013 Peterbilt 388**, Cummins 500 HP, jake, 18 spd, 20# fronts, quad axle, 4200 gallon steel vac tank, Fruitland 500 vac pump.  
**Call For Pricing!**



**2014 Western Star**, Detroit DD13 450 HP, 13 spd, jake, 264K miles, **NEW** 3500 gallon steel vac tank, **NEW** Masport Hydra vac pump.

**Call For Pricing!**  
**6-MONTH NATIONWIDE DRIVE TRAIN AND EMISSIONS WARRANTY**



**2010 Hino 268**, 220 HP, Allison Auto, NON CDL, **NEW** 1800 gallon steel vac tank, **NEW** Masport Viper fan cooled pump.

**Call For Pricing!**  
**1-YEAR NATIONWIDE DRIVE TRAIN WARRANTY**



**2005 Peterbilt 335**, Cummins 315 HP, 10 spd, 33# GVW, Low miles, **NEW** 2500 gallon steel vac tank, **NEW** Masport Viper fan cooled pump.

**Call For Pricing!**  
**1-YEAR NATIONWIDE DRIVE TRAIN WARRANTY**



**2012 Mack GU713**, Mack MP8 500 HP, jake, ONLY 155K miles, 13 spd, 18# fronts, **NEW** 3500 gallon steel vac tank, **NEW** Masport Hydra plug and play vac pump.

**Call For Pricing!**  
**6-MONTH NATIONWIDE DRIVE TRAIN AND EMISSIONS WARRANTY**



**2013 Peterbilt 365**, Cummins 425 HP, 8LL, jake, 13,200 fronts, ONLY 83K miles!, **NEW** 3500 gallon steel vac tank, **NEW** Masport Hydra vac pump.

**Call For Pricing!**  
**6-MONTH NATIONWIDE DRIVE TRAIN AND EMISSIONS WARRANTY**



## DISPATCHERS

Static/dynamic dispatching in real-time



## CLIENTS

Customer portal, 24/7 service scheduling



## SALES TEAM

Fully integrated CRM



## DRIVERS

Android / iOS user friendly app



## MANAGERS

Transparent detailed reporting



## ACCOUNTANTS

Activity based real-time invoicing & Credit Card processing



## ASSETS

Location & Inventory management

Phone: 1-844-276-2467

Email: [sales@crosoftware.net](mailto:sales@crosoftware.net)

Website: [crosoftwaresolutions.com](http://crosoftwaresolutions.com)

No Contracts

No Upfront Fees

Unlimited Updates

Unlimited Users / Drivers

Unlimited Support & Training





# SINGULAIR HK<sup>®</sup> GREEN

UNMATCHED NITROGEN REMOVAL



No Service For 18 Months!

- ◆ 84% Reduction of Total Nitrogen
- ◆ Exceptional Certified Effluent Results
- ◆ Simple to Install, Operate and Maintain
- ◆ No Complicated Recirculation Equipment
- ◆ Service Intervals Only Once Every 18 Months
- ◆ Rugged, Heavy Duty, UV Protected HDPE Tank



## GO GREEN! EXPAND YOUR BUSINESS



**SINGULAIR GREEN<sup>®</sup>**



**SINGULAIR R3<sup>®</sup> GREEN**



**HYDRO-KINETIC<sup>®</sup> GREEN**

PROGRESS THROUGH SERVICE SINCE 1906

1-800-NORWECO [www.norweco.com](http://www.norweco.com) [email@norweco.com](mailto:email@norweco.com)



# Office Technology

By Craig Mandli

**BUSINESS SOFTWARE**



**AllyPro**

Small companies shouldn't have to pay for enterprise-type software and mid-sized companies typically find themselves too big to be small, but not big enough to warrant a full-featured system. The result is **AllyPro**.

A version is available with tailored flexible features. Developed specifically for the portable sanitation industry, it allows companies to pass through stages without having to change systems, adding features to meet their requirements as they grow. Flexible settings coupled with dynamic and prompt customer service makes it adaptable to most service applications. Add managing almost any ancillary service and it becomes a complete system. Billing, CRM, dispatch, inventory, scheduling and field operations all combine to make the Essentials, Elite and Enterprise offerings. **888-974-8488; www.allypro.com**

**CRO Software Solutions**

**CRO Software Solutions** is a cloud-based, interactive asset management software solution designed for the solid and liquid waste industries. It is designed to solve real-world challenges of asset management by linking customers, drivers, dispatchers and managers on a simple interface. It offers ease of implementation and a simple initial setup. **844-276-2467; www.crosoftwaresolutions.com**



**Ritam Technologies Summit Rental System**

Besides single-click route optimizing, new features in the **Summit Rental System** from **Ritam Technologies** make route management easier and billing efficient. It includes mass email of notifications, such

as price changes, holiday hours and weather issues; projections of inventory available on any future date (especially useful for special events); Visual Dispatch route assignment by viewing nearby jobs on Google map view, color coded to route and day of week; route progress maps that show status of all jobs, color coded by route and status; photo capture of issues at the job and linked to the job history; a bread-crum map trail for comparison to the planned route (management by exception); disposal tickets, tracked and emailed as attachments with the next invoice; the ability to convert online customer requests to scheduled items; and auto-pay retry for any customers whose cards were previously declined. **800-662-8471; www.ritam.com**



**ServiceCore Software**

**ServiceCore Software** offers waste or roll-off business with a tool designed to cut wasted time, manages jobs, optimizes routes, tracks inventory and automates billing. **888-691-1333; www.servicecore.com**



**FLEET MANAGEMENT**



**DPL Telematics AssetCommand Base**

**AssetCommand Base** from **DPL Telematics** is designed to increase driver safety and productivity, while decreasing the costs and risk of vehicle accidents and theft. Managers

can remotely shut down their machines, wirelessly locate them anytime via GPS, collect odometer/run-time readings, track service intervals and receive real-time alerts for speeding or potentially dangerous driving. Driver ID options include iButton or RFID badges to restrict access to authorized drivers and correctly log each driver's activity. Users can also receive alerts for loss of power, boundary or curfew violations to curb unauthorized use. It is palm sized, has no external antenna and contains an internal backup battery to continue operating the unit if disconnected. Customers are allowed to deactivate and reactivate anytime without penalty. **800-897-8093; www.dpltel.com**

**Slate Pages app for portable restrooms**

The **Slate Pages** aluminum tag can help make managing portable toilets easier by automating information. The 2- by 3-inch aluminum tag is laser-etched with a QR code. The app (available on iPhone and Android) is used to scan the QR code and record important information related to the portable restrooms, including GPS coordinates, service dates and service history, delivery/pickup dates and customer information. Data gathered can be customized to specific company needs. Information gathered is sent to the Slates online dashboard where data can be viewed and tracked. Different data and map views can be created to show unit location, units in stock, unit condition, toilet servicing dates and more. **515-758-5463; www.slatepages.com**



**LEASING/FINANCING SERVICES**

**AP Equipment Financing application-only finance programs**

Application-only finance programs from **AP Equipment Financing** are available for businesses to purchase new or used revenue-producing equipment with costs up to \$200,000. Applications have become simplified with no need for paper. Businesses can apply through a smartphone or computer, with fixed payments so owners can keep peace of mind with monthly payments that match cash flow. **888-996-0305; www.apfinancing.com**



**tele radio**<sup>®</sup>  
 wireless solutions  
 SAFE • SMART • STRONG

**INDUSTRIAL  
 REMOTES FOR  
 JETTERS AND  
 VAC TRUCKS**



+1 305 459 0763    www.teleradio.com    sales@teleradio.com

AN **ALLGON**™ COMPANY

Tele Radio America, LLC

**ALL STAINLESS STEEL**

**12V DC Washdown Pump**

- 100% Solid Stainless Steel Pump Components  
 Corrosion Resistant Pump • No Plastic • Freeze Tolerant
- Open Face Impeller Design  
 Allows Debris to Pass
- 1 HP Totally Enclosed Motor  
 No Fan to Cause Problems
- Long Lasting, Dry-Run Seal
- Flow Rates to 25 GPM
- Pressure to 40 PSI
- End Suction with Top, Bottom,  
 or Side Discharge
- Quick Factory Shipment Available
- Other Pump Sizes and Materials Available

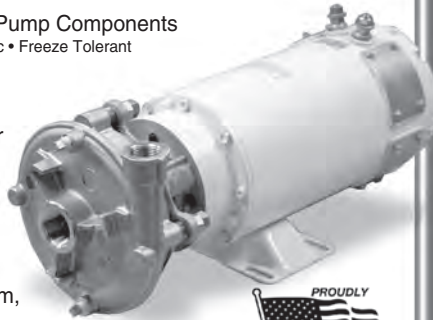

For More Information, Call **630-552-4115 ext. 2**,  
 Email **Pumper@MTHPumps.com**, or  
 Visit Us Online **www.MTHPumps.com**

**MTH PUMPS**  
 Manufacturing Pumps Since 1965



**MID-STATE**  
 TRUCK SERVICE, INC.



**WE OFFER ALUMINUM,  
 STEEL & STAINLESS TANKS,  
 AS WELL AS BLOWER &  
 VANE PUMP OPTIONS**

Contact: Cody  
 (715) 845-2244 ext. 4105 or  
 codyc@midstatetruck.com  
 www.MidStateTruck.com



**FULL PACKAGE FINANCING & LEASE OFFERS AVAILABLE**  
 PRICES DO NOT INCLUDE TAX, TITLE & LICENSING FEES – SEE DEALER FOR DETAILS





## CASE STUDY

### Restroom trailer operator uses QR codes to manage services by remote teams

**Problem:** Stahla Services offers luxury restroom and shower trailers to customers throughout the Midwest. Steve Mintie, Stahla's service manager, needed a consistent way to tell when the units are serviced, what was done, and if there were any issues with the unit or service. The process had to

be simple without adding the overhead to the service teams.

**Solution:** Stahla Services installed **AirVote QR Service Logs** on their trailers' A-frame by the waste valve. A single scan with a smartphone displays a service screen with six large buttons: Pumped/Cleaned/Filled Water/Repaired/Installed/Unable to Service. A tap on a button logs service activity, along with the current time and geolocation. A person can type comments, take a picture or record audio.

**Result:** Mintie now has a bird's-eye view of all service activities from different service teams and can follow up on issues in real-time. The system is being tested locally, with the plan to roll out to all remote sites in the next quarter. **425-314-3334; www.air-vote.com P**

## Screenco Systems LLC

Dual Screen Design

208-790-8770  
www.screenosystems.com  
sales@screenosystems.com



**PATENTED DUAL SCREEN DESIGN**  
US Patent No. D757,889S & US Patent Pending No. 29/680,577  
Your leader for simple innovative technology. Products built and field tested by industry professionals. Equipment that really works!

### MEGA SCREEN 600 & 800 RECEIVING STATIONS



- Largest Receiving Stations On The Market Mega 800 51 Sq Ft, Mega 600 40.5 Sq Ft
- Offload At 1000-800 GPM Through Dual Fan Spreaders 4", 6" or 8" Inlet
- 3/8" Gap SS Bars Meet Ecology 503 Regs
- Use For Industrial Truck Clean-out
- Offload 2 Trucks At Once
- 7' Trash Chute Bolts On Either Side
- Septic & Grease Receiving And Lift Station Trash

### NEW TRASH MASTER 400 RECEIVING STATION



#### Simplest Auto Screen In The Industry

- Uses Gravity To Separate Trash From Flow Screen
- 4" Power Offload From Truck 500 GPM Patent Pending
- 3/8" Gap SS Bars Meet Ecology 503 Regs
- Dewateres Trash - VFD 5-30 RPM
- Heavy Duty Shaftless Screw Moves Trash To Receptacle

### MAXI SCREEN 400 PORTABLE SEPTIC RECEIVING STATIONS



#### Aluminum & Stainless Construction

- 3/8" Gap SS Bars Meet Ecology 503 Regs
- Screens That Really Work
- No Moving Parts
- Gravity Off-Load At 500 GPM
- NEW 4' Trash Extension Puts Trash Directly Into Dumpster

Patented Dual Screen Design

### NEW MICRO SCREEN 400 PORTABLE RECEIVING STATION



- Place Over Frac Tank Or In Ground Storage Tank
- Bolts Securely To Manhole Ring
- 3/8" Gap Bars, 8 Sq Ft Screen Area
- Sealed Lockable Hinged Cover • Fast 4" Offload
- Lightweight - Portable • Small Footprint

**OUR SYSTEMS MEET ECOLOGY 503S**

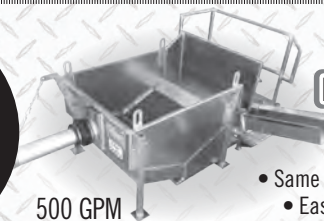

### MINI SCREEN 400 PORTABLE RECEIVING STATION

- Same Great Design, Ships Truck Freight
- Easily Fits In Pickup for Transport
- Small Footprint, Big Results

### TRIPOD LID & PUMP LIFTER



- Folds To Fit On Hose Deck
- Max Load 600 lbs
- Saves Back Injuries
- Auto Brake Winch
- Only Weighs 28 lbs
- Heavy-duty Aluminum Construction
- Available In 4-5-6 Ft Models
- Lifts Stubborn Tapered Lids

### GRIT ELIMINATOR



- Removes Grit From Flow Stream
- Keeps Onsite Storage Grit Free
- Available in 18, 32, 64, 96 Cu Ft Grit Capacity

### SHAFT DRIVE PUMPS & AGITATORS



- Move Septic And Grease Interceptor Waste With Ease From Underground Storage Tanks
- Great For Transferring To Land Application Site
- Mix While Dewatering
- Handles Sand Grit And Slurry Type Materials
- Pit Depths Of 3-12 Ft, 3333 Up To 500 GPM, 4444 Up To 1580 GPM

**Patz DISTRIBUTOR**

### TRUCK TOW BEHIND PORTASCREEN SPREADER

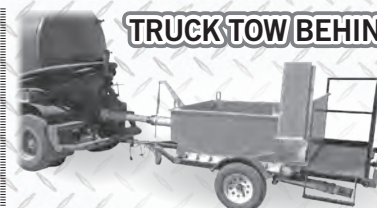

- Portable Event Screening
- Doubles As Screener Spreader & Mobile Septic Receiving Station
- Clean Up Your Land Application Site
- Never Hand Pick Trash Again



# ILLUMI-JET UV DISINFECTION UNIT®

## MODEL 952

- UL listed as a NEMA 6p enclosure (watertight submergence test)
- Install directly in ground or in pump tank on the effluent line
- Complete disinfection without the use of chemicals
- Hermetically sealed electrical components
- High capacity disinfection reservoir
- Kapton® seals improve serviceability
- Rated treatment of 10 gallons/min



Easy to service

Rugged construction

Dependable electrical design

Innovative disinfection design

*\*Replacement parts to fit most UV disinfection units*



www.jetincorp.com

**Jet**  
Wastewater Treatment Solutions  
*Founded on Innovation. Anchored by Service.®*

# Septic-Scrub™

**Used by More Professional Pumpers to Increase Their Business**

Backed By Science ■ Proven with Experience ■ Many Satisfied Homeowners

Septic-Scrub™ is a superior product for the maintenance and restoration of septic system drainfields. Customers appreciate that it is environmentally safe, contains no organic chemicals and does not produce any toxic by-products. Most importantly, **Septic-Scrub works.** It breaks down sulfide buildup in the biomat and soil to allow for better water absorption.

Learn more about Septic-Scrub at [www.arcan.com](http://www.arcan.com).

**arcan**

P.O. Box 31057  
Clarksville, TN 37040

For information on increasing sales and providing a valuable service to your customers, call Arcan Enterprises at **888-35ARCAN (352-7226)**



# Custom Trailer Solutions



Three Decades of Innovation

**Complete customization of restroom, shower, decontamination, & specialty trailers**



**AMERI-CAN**  
ENGINEERING

[www.ameri-can.com](http://www.ameri-can.com)  
**574.892.5151**  
Argos, Indiana



# ALLIED GRAPHICS

Your SOURCE for **DECALS** and MORE!

Our promise to you as our Customer

Responsive  
Customer Service

Competitive Pricing

Highest Quality

Free Artwork  
& Design

ISO  
9001:2015  
CERTIFIED

763.428.8365  
800.490.9931

www.allied-graphics.com  
sales@allied-graphics.com



## PRODUCT NEWS



in the **SPOTLIGHT**  
By Tim Dobbins

### HYDROEXCAVATOR PROMISES FULL-SIZE POWER IN A MID-SIZE PACKAGE

Hydrovac's designed for tight quarters are a must-have for operators servicing populated areas. For that reason, Tornado Global Hydrovac's engineered the F3 ECO-LITE to have big functionality in a mid-sized platform.

"We spent years of product development and leveraged our supply partners to design a unit that customers have been asking us to produce," says Rich Konkler, national manager of dealer development for Tornado Global.

"The F3 has been a popular choice in Ontario and the Toronto market since it was released," he says. "We are now beginning to see its effectiveness in the U.S. market."

The F3 Eco-Lite was made specifically to legally haul large payloads in urban environments, and does so with a debris capacity of 10 cubic yards and a water capacity of 1,250 gallons. A float-style indicator is positioned on the outside of the debris tank, so monitoring volume is quick and easy.

Outside of storage, Tornado Global equipped the F3 with a boom capable of reaching to 26 feet with 342 degrees of rotation and an 8-inch boom hose. The truck uses a 3,800 cfm Robuschi 125 blower, a Pratisoli KT28 water pump and a Dynablast 740,000 Btu burner.

A hydraulic dump door measuring 48 by 52 inches is mounted on the back of the tank and sits 42 inches high for easy use over bins. Operator comfort and efficiency was also top of mind for the build team. Customers can choose a 42-, 60- or 70-inch van body, and all van bodies are available with a toolbox, inverter, tooling package and wand holders.

Every unit has manual controls as well as a wireless remote system. The F3 also features a rear-view camera and premium work light package. "This is a mid-sized truck with full-size performance," Konkler says. "Its simplicity of operation is a favorite of operators."

According to Konkler, the F3 Eco-Lite can be used for a variety of applications. "This is a great support unit for the wastewater industry for excavating water lines and cleaning out retention ponds, exposing trenches, line repairs and locating services," he says. **877-340-8141; www.tornadotrucks.com P**

**Roth**  
MULTITANK

Septic Tanks • Water Cisterns  
Pump Tanks • Holding Tanks  
Rain Water Harvesting

Multi Usage      Multi Layer      Multi Coverage

- Inner layer of FDA approved virgin HDPE, two inside layers of PE for improved stability, plus one outer layer of black and UV-stabilized PE.
- Lifetime\* corrosion protection and 5 years of labor insurance
- Strongest & heaviest poly tank on the market
- No water for backfilling required
- Low profile
- 100% watertight

Our multi-layered tank construction, consisting of virgin material surrounded by 3 layers of protection.



**BEST TANK. BEST WARRANTY. BEST SYSTEM.**

Roth Global Plastics  
www.roth-america.com 866-943-7256

\*see warranty for details





### Kenworth releases medium duty Driver Academy video series

Kenworth released a Driver Academy video series for customers operating Kenworth's new line of medium-duty trucks. The videos include a walkaround of exterior features and their functions, an examination of interior features, and the proper procedures for pre-trip inspection. The video series is available on the Kenworth Truck YouTube channel and is also available on the Kenworth Essentials App, which can be downloaded to smartphones and tablets from the Apple or Google Play stores. **P**

### It's Your Magazine. Tell Your Story.

Pumper welcomes news about your company or services.

Send your ideas to [editor@pumper.com](mailto:editor@pumper.com).



#### Join Us Online



[Facebook.com/PumperMag](https://Facebook.com/PumperMag)



[Twitter.com/PumperMag](https://Twitter.com/PumperMag)

[LinkedIn.com/company/pumper-magazine](https://LinkedIn.com/company/pumper-magazine)



**Custom Manufacturers of**  
>Restroom Trailers >Shower Trailers  
>Transport Trailers



**269-435-4ART** (4278)  
[www.aRestroomTrailer.com](http://www.aRestroomTrailer.com)  
[info@arestroomtrailer.com](mailto:info@arestroomtrailer.com)  
Constantine, MI



**KILL THE ROOTS.  
GROW YOUR  
BUSINESS.**

When root intrusion occurs, you know who to call. Thanks to our customer registration program, so will your customers.

**Call us today to learn more about the RootX® Customer Registration program and current pricing and specials.**

**New customers receive 10% off your first order by mentioning this ad! \***

**1-800-844-4974**  
**rootx@rootx.com**

*\*Restrictions apply. Call for details.*



OUR BEST SELLING DRAIN LINE JETTER!

# HOTJET II

10GPM @ 4000 PSI • 35HP VANGUARD  
Cleans 2-12" Drains with Hot OR Cold Water



TRAINING AND FREE WARTHOG NOZZLE INCLUDED!

OVER 30 YEARS BUILDING QUALITY EQUIPMENT

## HotJetUSA

1-800-624-8186  
WWW.HOTJETUSA.COM

PRICES SUBJECT TO CHANGE - CALL FOR CURRENT PRICING



# SURCO

PORTABLE SANITATION PRODUCTS

## XTREME

### BEST Water Soluble Packets



PORTABLE SANITATION PRODUCTS  
800.556.0111  
surco.com

## EASY-KLEEN

PRESSURE SYSTEMS LTD.  
MANUFACTURER OF HIGH PRESSURE CLEANING EQUIPMENT

### VAN PACK JETTERS

12 GPM @ 3500 PSI



## SIM/TECH FILTER

Toll Free 888-999-3290

### STF-100 series pressure filter

- » Lower total suspended solids (TSS)
- » Protect with low head-loss (.5002 ft)
- » Extend the life of the distribution field
- » Filter to .062", .024", .007", or .004"
- » Pass up to 83.8 gallons per minute @ 1PSI
- » Allow for easy installation and service
- » Protect from improper system maintenance
- » Protect from system abuse
- » Satisfy your customers

US Patent# 5,885,452  
CAN Patent# 2,237,751

[www.simtechfilter.com](http://www.simtechfilter.com)

# AMT

A Gorman-Rupp Company

*The Pump People*

Please visit us at [www.amtpump.com](http://www.amtpump.com)

## What's That?



# RNV

A Division of Truebrite Inc.

## HYDROVAC

[www.RNVac.com](http://www.RNVac.com)  
[sales@RNVac.com](mailto:sales@RNVac.com)  
Apalachin, NY  
(607) 786-2139

## OPEN JETTER TRAILERS

### GROUNDHOG JETTER



20 GPM @ 4000 PSI

### ENCLOSED JETTER TRAILERS (Hot Water)



## EASY-KLEEN

PRESSURE SYSTEMS LTD.  
MANUFACTURER OF HIGH PRESSURE CLEANING EQUIPMENT



R. Nesbit Portable Toilets introduces:

## The Sani-Klip

A COST EFFECTIVE SOLUTION FOR PROVIDING ALL OF YOUR CUSTOMER'S HAND SANITIZER



CONTACT: KATIE/AMY  
R. NESBIT PORTABLE TOILETS  
**724-652-8232**  
[www.best-portable-toilets.com](http://www.best-portable-toilets.com)



## 2023 TREMCAR

### Vacuum Units In Production

Reserve yours now!

- Aluminum Barrel
- Aluminum Subframe
- 12000 Gal. Capacity
- 1 Compartment
- Air Ride Suspension
- Disc Brakes
- Aluminum Rims
- Rear Discharge
- (Optional) Hydraulic Vac Pump/ Hydraulic Vac Blower

**CALL CHAD FOR PRICING**  
734-552-2805  
[www.UnitedTankTrailer.com](http://www.UnitedTankTrailer.com)

## CONFINED SPACE ENTRY PACKAGE

ONLY \$3,195

### The Best Package On The Market Includes:

- 4-Gas Air Monitor (3 Year Sensor Warranty)
- 7' Tripod
- 3-Way Fall Protection
- Work Winch
- Full Body Harness



Add a Blower with 15' of duct for only \$400!  
Add a 5 Minute Escape Respirator for only \$500!

**MTECH** 800.362.0240  
[www.mtechcompany.com](http://www.mtechcompany.com)

## VACUUM TRUCK HEATERS

440,000 BTU to 4,000,000 BTU



YouTube  
[www.youtube.com/easykleen](http://www.youtube.com/easykleen)

**1-800-315-5533**  
[www.easykleen.com](http://www.easykleen.com)  
[sales@easykleen.com](mailto:sales@easykleen.com)

## T&T Tools, Inc.

**800.521.6893**

CALL FOR A FREE Catalog

Many styles Available



Insulated Soil Probes (for locating)      Heat-Treated Hooks (for covers, lids, etc)

[www.mightyprobe.com](http://www.mightyprobe.com)





**Wolverine Filters, now with a built-in end-of-service-life indicator.**

Simple Solutions  
DISTRIBUTING LLC 973-846-7817 in NJ  
sales@industrialodorcontrol.com  
IndustrialOdorControl.com

866-NO-STINK  
(866-667-8465)

**Superior<sup>®</sup>**

**SMOKE**

**Find Leaks and Sources and Odor**  
Fast • Inexpensive • Easy

MADE IN USA



**Superior 5E Electric Smoker**  
SuperiorSignal.com/Pumper

Surco  
**Potty Fresh Plus**  
Portable Toilet Deodorant



**Powerfully-effective odor control liquid portable toilet deodorant!**  
Non-Formaldehyde • Deep Blue Non-Staining Dye

**SURCO**  
PORTABLE SANITATION PRODUCTS  
800.556.0111  
surco.com

**EASY-KLEEN**  
PRESSURE SYSTEMS LTD.  
MANUFACTURER OF HIGH PRESSURE CLEANING EQUIPMENT

SINCE 1982  
FAMILY OWNED & OPERATED  
BUILT TO LAST  
WOLVERINE  
DRY STEAM GENERATORS

**DRY STEAM GENERATORS**



20/30/40/50 BHP  
Up To 2,000,000 BTU

- Curing
- Thawing
- Degreasing
- Degassing
- Melting
- Cleaning & Restoring
- Prepping Surfaces for Paint
- Purifying
- Weed Control

YouTube  
www.youtube.com/easykleen  
**1-800-315-5533**  
www.easykleen.com • sales@easykleen.com

**AMERICAN JETTER.COM**



51T Trailer Jetter Hot or Cold  
20 GPM @ 4000 PSI  
76 HP Kohler EFI  
FREE Shipping/Delivery



58 Trailer Jetter Hot or Cold  
10 GPM @ 4000 PSI  
38 HP Kohler EFI  
FREE Shipping/Delivery

**866-944-3569**

**ARCTIC BLASTER**



- > Perfect for all your thawing needs
- > Thaws pipes above & below ground
- > Use on plastic, copper or ABS
- > Perfect for roof drains

**Valve Heaters for your Septic Truck Arctic Valve Heaters**

- > No piping changes or welding needed on your truck.
- > For: 3", 4" or 6" MZ Lever Valves
- And: 4" or 6" Betts Valves
- > Developed by the inventor of the Arctic Blaster

Heat the Valve,  
Not the Sewage

And They Work!

ARCTIC BLASTERS INC.  
SUNDRE, ALBERTA  
403.638.3934 • ArcticBlaster.com

**Irwin Septic**  
Pumping - Plumbing - Repairs  
(920) 888-8712

**FREE PRIVATE LABELING**  
Drainfield Solutions  
Root Control - Septic Solutions  
Grease Solutions

**www.lenzyme.com**  
**800-223-3083**

*The Shaddix Company*

**Custom Made To Your Specs Truck Beds & Forms**



1500 & 1000 Gal.  
2 Compt. Septic Tank Forms



Septic Tank Delivery Beds

Call Dewayne for a quote!

**256-737-0051**  
www.shaddix.us

*Fresh Content*

IS KEY TO YOUR COMPANY'S MARKETING STRATEGY...

LOTS OF IT.

COLE Media's content generation team specializes in custom-built, affordable solutions exclusively tailored to fit your needs.

**COLEmedia**  
800.257.7222 | cole-media.com

**DREDGING & DEWATERING SERVICE**

- Municipal and Industrial • Digester and Lagoon Cleaning
- Double Belt Filter Presses • Liner Repair & Replacement

**Fluid Technology, Inc.** (513) 241-1600  
Fax (513) 756-1995  
www.fluidtechnologyinc.com

We own the name.  
You've earned the name.

**Pumper** Since 1979





# CLASSIFIEDS

See photos in color at [www.pumper.com](http://www.pumper.com)

## BUSINESSES

Highly reputable & thriving septic tank & cesspool cleaning company for sale in Nassau County, NY. Our excellent reputation promises tremendous opportunities for growth & expansion. Servicing prominent areas of Nassau & Suffolk Counties since 1972. Owner is now looking to retire. Owner is willing to stay on & train new owners temporarily. If interested, please contact us for more information: 516-922-1242 / EastNor14@yahoo.com (P12)

For sale: Portable toilet company servicing Central and North New Jersey. Current 12 months sales at \$2,500,000.00. Company and all equipment minus the licensing included in the sale. Please email toilet-sales101@gmail.com if you're interested. For additional information we ask that a non disclosure agreement be signed. Thank you very much. (P11)

35+ Years Septic and Portable Toilet Business for sale in beautiful Upstate NY, Otsego (Tioga County). 150+ regular portable units, 20 ADA handicap units, 20 sinks and 5 holding tanks. 2007 F550 4x4 toilet truck, 2013 550 4x4 Ram toilet truck, 2013 3400/250 International tanker, 2020 3400/300 Peterbilt tanker. Over \$500,000 in sales annually. Willing to train new owner. Serious inquires only 607-725-3963 or email contact@tiogasanitary.com. (P10)

Join a Growing Organization. If you thought about selling your pumping business now is the time to contact us for a serious discussion about a potential acquisition. We are a growing company covering Rhode Island, Massachusetts, Southern New Hampshire and Connecticut via our Massachusetts and Rhode Island locations. We would like to speak with you about your business, employees, and equipment today. Please contact us, leave your company name, your name, contact number and e-mail and we will be in touch (all calls go to answering service and you will receive a call back quickly). Looking forward to speaking with you. Thank you Consultant Services, Inc. (401) 339-9992 (PBM)

Well-established, full-service septic system contracting company operating in South Florida for over 70 years, specializing in inspections, pump outs, repairs, new installation of tanks & drainfields, and certifications. Currently pumping 200,000 to 300,00 gallons of residential/commercial tanks per month and installing over 150

tanks and drain fields per year. Well-maintained and working vacuum trucks, dump trucks, backhoes, track machines, and trailers. Serious buyers may inquire by email to dean@ddlawoffices.com (P10)

Sunny Florida septic business for sale with two trucks and all equipment. Established 38 years. Specializing in drainfields, tank installations and repairs. \$789,000 negotiable. Commercially-zoned house & office available for an additional \$250,000. Serious inquiries only. Call for more info. 727-848-3401. (P10)

[www.RooterMan.com](http://www.RooterMan.com). Franchises available with low flat fee. New concept. Visit web site or call 1-800-700-8062. (PBM)

## DRAINFIELD RESTORATION



**New & Used TERRALIFT machines**  
Terralift parts and beads. Aeratech Solutions LLC, 413-394-4567 or cell- 413-441-1140. Call and learn how the TERRALIFT machine can earn your business an **extra \$250,000 in revenue a year.** (PBM)

## HAZARDOUS WASTE UNITS

2006 IH 9200i with sleeper and Progress 2,850 U.S. gallon, Aluminum, D.O.T. 412 certified, vacuum tank with Wittig RFL100 vacuum pump and 3" transfer pump. Stock# 2897C [www.vacuumsalesinc.com](http://www.vacuumsalesinc.com) (888)VAC-UNIT (822-8648). (PBM)

1997 Ford with Cosco 3,200-gallon DOT certified dump and door liquid vacuum truck. Cat engine with Moro M9 vacuum pump. Runs and pumps excellent. \$37,500. KLM Companies 617-909-9044 (PBM)

2000 International with Cosco High Dump 27", DOT Certified, 412 with vacuum pump, pressure offload as well. Cummins Power with low miles and hours. KLM Companies 617-909-9044. (PBM)

**Pumper Classifieds Work!**

## JETTERS - TRAILER



**2001 U.S. Jetting**, Model 4025, 25 GPM @ 4000psi, upgraded remote performed by U.S. Jetting, solid machine, everything works. **\$35,000, Scott 706-832-5224 I can send more pictures if he needed.** (P10)

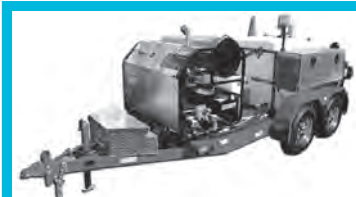

**The HotJet II®** is a best-selling hot and cold-water drainline cleaner featuring a 35hp Vanguard engine by Toyota and delivering 10gpm @ 4,000psi that cleans drains up to 300' and 12" in diameter. The HotJet II® is American made using nonproprietary parts for affordability and ease in serviceability making its return on investment truly impressive. Prices subject to change. Financing available. Contact us for current pricing and availability **800-624-8186; sales@hotjetusa.com; www.hotjetusa.com** (PBM)

2001 Harben DTH-300 jet trailer with a Harben radial piston diaphragm pump 16 GPM @ 4,000 PSI driven by a Hatz diesel engine. Stock #1386V [www.vacuumsalesinc.com](http://www.vacuumsalesinc.com) (888)VAC-UNIT (822-8648) (PBM)

1999 Harben 4016-300 Jet Trailer (Stock #200SC) (888)VAC-UNIT (822-8648) [www.vrentalsllc.com](http://www.vrentalsllc.com). (PBM)

## JETTERS - TRUCK

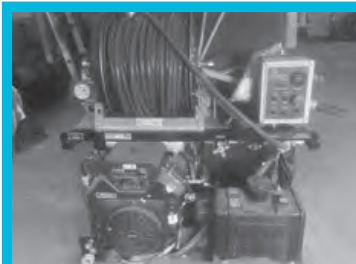

**Mongoose slide in van jetter** on skid. Only used twice. Please contact Rachel **508-429-9016. rachele@rodenhiser.biz** (P10)

2000 F650 Jetter Truck. Cat 190HP 215,000 miles non CDL. 1000 gal water tank. Myers pump 65 gpm / 2000 psi driven by Ford 240 series 6 cylinder. 400' of 1" hose included. Hydraulic reel holds up to 600'. Work ready. \$15,000 obo. Email [jmack884@gmail.com](mailto:jmack884@gmail.com) for more info (P10)

## JET VACS



**Your Environment's Solution - 2002** Aquatech Jet Vac 289,000 Miles- Good solid working truck. **Asking \$37,500.00 (obo) Dalton Seagraves 407-426-8803** (P10)

Pre-owned Vactor 2100 combination jet/vac unit with PD blower And 10 cubic yard debris tank. Mounted on a 2002 International 7400 cab & chassis. Stock # 1138C (888)VAC-UNIT (822-8648) [www.vrentalsllc.com](http://www.vrentalsllc.com). (PBM)

2021 Freightliner 114SD cab & chassis with VACALL AJV1215 combination j/vac with 12 cubic yard debris and 1,500 gallons of water with a Roots 824 blower & general MWSR50 water pump. Stock# 057R (888)VAC-UNIT (822-8648) [www.vrentalsllc.com](http://www.vrentalsllc.com). (PBM)

## LEASE/FINANCING

Western Equipment Finance, a bank-owned direct lender, is committed to continuing to help you prosper. All Equipment Types, New or Used; we have the best rates and terms you deserve. App-Only Financing and credit decisions within an hour. Call the team you can TRUST, Jim Stekl at Western Equipment Finance 701-665-1647. [jim.stekl@westernequipmentfinance.com](mailto:jim.stekl@westernequipmentfinance.com) (PBM)

If you are using an  
**800 NUMBER**  
in your ad, be sure it can be used in all areas nationwide.

**LIST YOUR EQUIPMENT IN PUMPER CLASSIFIEDS!**  
[www.pumper.com/classifieds/place\\_ad](http://www.pumper.com/classifieds/place_ad)

PLACE YOUR AD ONLINE AT [WWW.PUMPER.COM](http://WWW.PUMPER.COM) - IT'S ALWAYS THERE TO MEET YOUR BUSY SCHEDULE



## PARTS & COMPONENTS



**Clear the Main Line with ease,** JnA Main Line Vac. Just hook the line vac to your hose, insert the incoming mainline pipe and watch the line come clean. Works on 3" & 4" pipe. Free shipping in the US. \$139.99. **Order at [jnamainlinevac.com](http://jnamainlinevac.com). 919-559-9344. (PBM)**

## PORTABLE RESTROOM



**200 Gray & Orange Satellite** High Tech Units for sale. All in rentable condition. Customer is responsible for pick up or shipping from NY. \$315.00 each. **Call 1-800-634-2085 (P11)**

40 Brand New, Unused, portable toilets. \$500 each. TBlueStar - RapidLoo Pro. Contact for more info/photos. 757-618-5467 (P10)

Used Portable Toilets for Sale, All in Rentable Condition. 50 Orange/Grey Satellite High-tech, 50 Grey PolyPortable Integra, 50 Tan PolyPortable Integra. \$250 each. Customer is Responsible for Pick-up/Shipping in NY. Please contact (800) 634-2085 (P10)

## PORTABLE RESTROOM TRAILERS



**50 new portable restroom units** (1 ADA). 6 hand washing stations, 16-unit restroom hauler. 2-unit hauler. Multiple water tanks and gray water holding tank. Wide range of parts and supplies. Package deal for everything. **\$70,000 OBO. 719-666-2553. (P10)**

2001 Keith Huber International pump truck. 2 Decons, 28' Tonto, 18' Royal, 2001 ASCI, 16' Presidential, 26' Presidential, portable toilet hauler trailers. 315-437-1291, NY (PBM)



**6 units available for 2003, 24-foot** Olympic Fiberglass Restroom Trailer - In Rentable condition as is. Women's side has three stalls; Men's side has two stalls and three urinals. Buyer is responsible for Transport from New York. **\$6500.00 - Call 800-634-2085 (P11)**

## PORTABLE RESTROOM TRUCKS



**2007 Ford F750** fully refurbished by Stephenson Specialty Trucks. New Cat C-7 engine with Blackwater warranty still valid - engine has less than 10,000 miles on it. Full paint job on the cab, frame and engine. Refurbished the grill, headlamps, seats and headliner. New: 4 outside aluminum wheels and 6 new tires. The tank is 1500 waste / 500 freshwater. Aluminum tank has been completely rewired, new valves, hatches and turnbuckles. Hose tray was refurbished. New Toilet Rack/Bumper assembly. New 12v wash-down pump and hose reel. Masport pump HXL4. **Priced to sell \$70,000. Call 785-564-2723 or email [catcansofmanhattan@gmail.com](mailto:catcansofmanhattan@gmail.com). Local pick up only in Parsons KS. (P10)**



**2009 Best Enterprises** Built Stainless Steel Tank with Skirting and Conde SDS series pump. Tank in brand new condition and ready to mount. 1050 total gallons, 750 waste and 300 water. This set up brand new costs \$36,000. **We have SIX of them for sale for \$19,900. Contact us at 1 800 634 2085 in New York. (P11)**



**2006 Ford, LCF, Porta Pot** truck, 4.5 liter Powerstroke, Allison Auto, 98k miles, AC, cruise, under cdl, Crescent 650 gal waste tank, 350 fresh water tank, 6 pot bed with lift gate, Masport vac pump, freshwater pump and reel. Very clean, great running truck. Financing and delivery available, **\$35,000.00. Hull's Truck Bodies, LLC 740-820-5338 (P10)**



**Combo restroom/septic pumper** 2007 Pete 335 240,000 miles 2014 aluminum tank 2000 waste 200 chemical 100 fresh water to hose reel. Two unit hauler on back. Call Derek. **785-477-2254 (P10)**



**2019 Ford 550 Gas V10** with Flowmark Aluminum Tank (900 Waste/400 Fresh). NVE 304 Vacuum pump and DC10 Wash Pump. Outside pump controls and 2 unit toilet hauler. 110,000 miles, still on daily routes, and works great. **Asking \$69,500. For more info and pictures email [info@dakotaportabletoilets.com](mailto:info@dakotaportabletoilets.com) (P10)**

2013 F550 4x4 diesel 600-300 176,xxx miles Red \$31,500 runs good pumps good No hoses call 507-210-1722. (P10)

Pre Owned 1993 Mack RD688S cab and chassis with a 3,200 U.S. Gallon, carbon steel, dump type, vacuum tank unit. Stock# 4296C **[www.VacuumSalesInc.com](http://www.VacuumSalesInc.com), (888) VAC-UNIT (822-8648). (PBM)**

2017 Hino 195 with Crescent Tank750/350 with Lift Gate. Haul up to 8 Units. Automatic with 118,669 miles. Runs great. Bought new fleet in 2021/2022. \$55,000 Mike. 216-990-6658 (P10)

## Pumper Classifieds Work!



**2015 Ford F750** portable restroom truck with Arthur custom built aluminum tank 1500 waste / 500 fresh. Tank was built by FlowMark in 2014. Truck has a Cummins engine 1SX15 with 146,105 miles on it. We have added a new unit hauler, hose reel, DC-10 wash down pump, new wiring and control box for the pto, lights and water. Vac pump is a Masport HXL4. 26000 gvw truck. Truck is local pick up only in Manhattan Kansas. **Priced to sell at \$70,000. Call 785-564-2723 or email [catcansofmanhattan@gmail.com](mailto:catcansofmanhattan@gmail.com) (P10)**

New Imperial 1300 U.S. gallon, portable toilet service unit mounted on a 2022 Ford F550 cab and chassis with a Masport HXL4 pump package. Stock # 14029. **[www.VacuumSalesInc.com](http://www.VacuumSalesInc.com) (888) VAC-UNIT (822-8648). (PBM)**

## PUMPS

Buy & Sell all makes and models, new & used vacuum pumps, blowers, high-pressure water pumps, new and good used replacement parts. Buy discounted pumps online 24/7. Call us for a current inventory list. **[www.VacuumSalesInc.com](http://www.VacuumSalesInc.com), (888) VAC-UNIT (822-8648). (PBM)**

## RENTAL EQUIPMENT

2023 Polar Vacuum Trailer: Stainless steel 6,000 gallon, DOT certified double conical with air-ride suspension. Aluminum wheels all positions, full hose trays, OSHA walkways and railings. Vacuum pump option either hydraulic or self-contained. KLM Rentals Inc. 617-909-9044. (PBM)

Liquid vacs, wet/dry industrial vacs, combination jetter/vacs, vacuum street sweeper & catch basin cleaner, truck & trailer mounted jettors. All available for daily, weekly, monthly, and yearly rentals. VSI Rentals, LLC, **(888)VAC-UNIT (822-8648) [www.vsirentalsllc.com](http://www.vsirentalsllc.com). (PBM)**

## SEPTIC TANKS

Pre-owned 1,500 U.S. gallon (500 water-1,000 waste) carbon steel, portable toilet service unit tank with rear toilet carrier. Stock# 1500V **[www.VacuumSalesInc.com](http://www.VacuumSalesInc.com), (888) VAC-UNIT (822-8648). (PBM)**

**Submit your classified ad online!** [www.pumper.com/classifieds/place\\_ad](http://www.pumper.com/classifieds/place_ad)



## SEPTIC TRUCKS



**2000 Pete, C12 Cat 425h.p.**, 231k, 8LL trans, Jake, AC, cruise, 46 rears, 18 front, 20k lift, Newer 5000 gal tank and Wittig vac pump, new paint and tires. Very nice clean truck. Financing and delivery available. **\$75,000.00. Hulls Truck Bodies LLC 740-820-5338 (P10)**



**2008 Mack 700 8 speed** standard Mack motor, 5200 gallon aluminum Progress tank, 498K miles, runs and drives great, company went out of business. \$38000. Located in NH. Contact info: **David Iverson 603-494-6381 DKIverson@metrocast.net (P10)**



**2012 freightliner Coronado ISX 15** Cummins motor complete rebuild with receipts. 429,731 miles good AC everything works 18 speed fuller transmission with new clutch 30k miles ago. Fruitland 500 LUF vacuum pump. Good vacuum. Have new rebuild kit, will come with purchase a truck. Cleaned the tank completely out. 5000 gallon Pike-rite tank **209-968-8095 Mike. Text me for additional photos. (P10)**



**International 4700 466dt** lots of new parts. Very good truck, runs great. **\$34,000 OBO Ryan 1-307-640-1593 2001. (P10)**



**2015 Peterbilt Model 348** 10 wheeler septic truck - 4000 gallon Transway tank with RFL 1200 vacuum pump - Aluminum Dura bright wheels with 75 percent rubber - 207,627 miles on original Paccar 350 horse engine - Immaculately taken care of by driver since new - 50 pictures can be emailed. **Contact Jim @ 610-716-4031 \$125,000. (P10)**



**2005 International, ISX Cummins** 435h.p, 371k miles, 10-spd, Jake, AC, cruise, New 3600 gal tank, stainless hose trays, Fruitland 500 vac pump, tires, alum wheels, paint. Extremely clean southern truck with all new equipment. Financing and delivery available, **\$85,000.00. Hull's Truck Bodies LLC 740-820-5338 (P10)**



**2013 International. 10 Speed** Eaton Fuller Transmission. 3000 Gallon Tank. Replaced full fuel rail and high pressure fuel pump less than 100 miles ago. Runs great, pumps great! Ready to go to work today! **Call Clay at 903-821-7752 for more details. \$75,000. (P10)**



**2008 Freightliner Day cab** with rarely used PTO powered vacuum pump. Extremely well-maintained tractor with zero issues or leaks. Like new 4,200-gallon tanker trailer inside and out. Only ever used for non-potable water. New rubber all around, huge bonus in itself! DOT Certified. **\$71,500. 719-666-2553. (P10)**



**1992 International dt 466** pump truck. **Call 631-662-9910 Please leave a message. (P11)**



**2023 HV607 International SBA, L9** Cummins/3500 Allison Auto, 3600-4200 gallon steel or aluminum tank, NVE 4310 OR Masport 1000 blower. **Call RAY Today @ 501-388-9565 (P10)**



**99 Mack, 400 h.p Mack engine,** 265k, 8LL trans, Jake, AC, cruise, camelback suspension, Newer 3500 gal tank and Masport 400 vac pump, 100 gal wash-down tank and pump, very nice running clean truck, ready to work. Financing and delivery available, **\$35,000.00. Hulls Truck Bodies LLC 740-820-5338 (P10)**



**2001 Kenworth T800,** 4800 Gallon Tank, NVE 866 Vacuum Pump, C12 Cat Engine, Heated Valves, 20,000 Front Axle, Pusher Axle, Fresh DOT, Fresh Maintenance, Ready To Work! **\$52,000 612-816-8013 (P10)**

1994 Mack DMM 690 (6x6), 275 HP, 6 speed, 3600 gallon Lely-Steel Tank, Masport 400 Pump-Hydraulic Driven, Air Operated Dump Valve-Rear 6", A/B, P/S, 20000 Front, 44000 Rear, Floatation front tires, 12R x 22.5 Rear. \$29,500 Call Bob @ 352-796-4540 (P10)

**Submit your classified ad online!**  
www.pumper.com/classifieds/place\_ad



**2019 F 750 Vacuum truck,** 2500 gallon capacity, very low miles ( 30,000). 300ft of vacuum hose, dump hose, leader hose, 2 large jockey boxes. Power steering, power brakes, tilt wheel, cruise control, power mirror's, power door locks. Only driven by owner, truck is in pristine condition and original owner. Ready to go to work. **\$150,000.00 OBO. Call John 661-802-9656 (P10)**



**2002 International. Cummins turbo** 330 . Fuller 10 speed trans. NVE challenger defender pump 363 CFM (new in 2018) 3,600 gal tank, 315 k miles, truck is very reliable, ready to go to work. **\$39,500. OBO 740-819-6848 (P10)**



**TRACTOR 2019 Peterbilt 567** 125,000 miles Paccar MX13 Engine 515 HP High Fuel Efficiency Engine Eaton - Fuller 10 Speed Transmission New Turbo Just Installed DPF Filter Cleaned and Exhaust Sensors Replaced PM Performed 5,000 Miles Ago PM Performed Every 10,000 Miles Have All Receipts For Service Work CHASSIS Heavy Spec Factory Double Framed 20K Steer Axle W/ Front Disc Brakes 20K Steerable Tag Axle 44K Rear W/ Air Ride Rear Differential Full Locker on Both Drive Axels 22.5" Polished Aluminum Wheels 425 Series Full Floater Front Tires @ 40% 5 Brand New Rear Tires on Rear Drive Axels Brakes @ Steer Axle 100% Brakes @ Drive Axels @ 90% Brakes @ Tag Axels 70 % TANK Amthor 5,000 Gallon Polished Aluminum Tank 6" Dump Valve 4" Bottom & Top Loader Valve 4" Side Loader Valves Driver's & Passenger's Side Garnet See Level Annihilator Digital Gallon Meter NVE 4310 Blower and Gear Box Replaced August 2021 Asking Price: \$225,000 or Any Reasonable Offer Will Be Considered **Please Call, Text or Email James Mobile: 512-426-1288 Email: ajlwhlhc@gmail.com (P10)**

**Pumper Classifieds Work!**

PLACE YOUR AD ONLINE AT [WWW.PUMPER.COM](http://WWW.PUMPER.COM) - IT'S ALWAYS THERE TO MEET YOUR BUSY SCHEDULE





**2006 International Cummins ISM** 370hp with 209k miles on overhaul with paperwork, 10 speed, new 3600 gal tank and new Juroop R260 vac pump, new paint, new tires and aluminum wheels. Very nice clean truck. Financing and delivery available, **\$75,000.00 Hulls Truck Bodies LLC 740-820-5338. (P10)**



**1997 Ford pump truck with jetter** 3500 gallon waste tank Cat 4 engine runs good. **Price \$29,000. 561-302-7195. (P11)**



**2011 Peterbilt C13 Cat, Allison Auto,** Jake, AC, cruise, 4200 gal Pik Rite tank and Masport 400 vac pump, very clean great running truck. Financing and delivery available, **\$79,000.00. Hull's Truck Bodies, LLC 740-820-5338 (P10)**



**Truck is a 2008 Hino 268,** tank size is 1500 gallons. It has 91k miles, The truck is in great condition. Has an Allison automatic transmission. **Mike Dovlatyan, 818-373-9282 is my phone number. (P10)**

1989 Mack "R" 690T, 2500 Gal "Lely" steel tank. Moro Pump, 300 HP 4 Valve Engine, 5 Spd Trans, P/S, A/B, S/A, A/C, Tinted glass, 12000 front, 21000 Rear, Tool boxes, Dual Fuel Tanks, Side Vacuum 4" left side, Air Operated Rear Pump Valve, \$24,500. Call Bob @ 352-796-4540 (P10)



**2012 Volvo VHD, D13 Engine 405 HP,** Eaton 8LL Trans., Full Locking Rears, 218k Miles, Heated Mirrors, Air Ride Seats and Cab, Hoist bed, 3,850 Gal Alu Tank, Rear Camera, Sea Level Gauge, 3" Load and 6" Dump Valve, Newer Tires, Wittig RFW150 Pump 500 CFM, 2 spare pumps, Mechanical maintained with an open checkbook. Indianapolis, Indiana **\$97,500 obo 317-539-7304 (P10)**



**2012 custom Peterbilt 386** deleted pacar 500+hp. 770k. Eaton 10 speed manual. Longhaul truck conversions are typically more well maintained. This one is 3 plus years since build and still rolling everyday. Masport 400HXL liquid cooled, 2, 3" intakes 1 heated 1 over baffles not. 1, 6" auto discharge stainless heated. Dual rear led work lights. 1 pump led side work light. Partial split locking dif. Rear air ride dump. All controls integrated into existing dash less pto. All tires are 90% and has super single fronts. Needs new steering box and tag brakes. Can work into price or replace prior to sale. New oil cooler. Truck serviced annually. Won't find another one like it. Imperial 4,600 gallon tank with new mounts, frame bolts and springs. New pump suction hoses and 240' tiger suction hoses. 40' sections. Crustbuster not included. 69 gallon fuel and toolbox. Much more. **\$100,000 obo. Ben 651-888-0559. (P10)**



**2006 Sterling Septic Truck For Sale.** 3600 gallon tank, comes with hoses. NVE Vacuum Pump. New tires. Mileage 370,000. New motor with 55,000 miles. **\$40,000/obo. Call Ray at 315-796-7150 or kirleyseptic@frontiernet.net (P10)**

New 4,000 U.S. gallon, aluminum, vacuum-pressure tank mounted on a 2023 Peterbilt 548 cab & chassis with NVE Challenger 887 fan cooled vacuum pump Stock #14056 **www.VacuumSalesInc.com, (888) VAC-UNIT (822-8648). (PBM)**

Pre-owned 3,600 U.S. gallon, Aluminum vacuum tank; with a Presvac PV750 vacuum-pressure pump installed on a 2004 Peterbilt 330 cab and chassis. Stock# 1693 **www.VacuumSalesInc.com, (888) VAC-UNIT (822-8648). (PBM)**

New 4,000 U.S. gallon, aluminum, vacuum tank. Mounted on a 2023 Freightliner M2-106 cab and chassis w/ a NVE Challenger 887 vacuum pressure pump package. Stock# 14056 **(888)VAC-UNIT (822-8648) www.vsrentalsllc.com. (PBM)**

Pre-owned 2000 Mack RD686S cab & chassis with a 4,000 U.S. gallon, carbon steel, vacuum tank unit. (Stock #0514CV) **www.vacuumsalesinc.com (888)VAC-UNIT (822-8648) (PBM)**



**2023 Freightliner 108 SD** with 4000 gallon all waste steel tank GVW 58,000 40,000 Rear axle 18,000 Front axle 20,000 lb axle 3rd Air Cooled Fruitland 500 Vacuum Pump 6" dump 2 - 4" suction pipe **\$202,000.00 Plus 12% FET Tax Rodney Lane 270-832-3793 (PBM)**



**2011 Ram 5500.** Aluminum tank 400 fresh/1,000 waste. Masport pump. Cummins engine. **720-436-3910. (PBM)**

Pre-owned 2,800 Gallon, Aluminum Vacuum Tank. pump. **www.vacuumsalesinc.com Stock #1852V (888)VAC-UNIT (822-8648) www.vsrentalsllc.com. (PBM)**

2014 Freightliner Cascadia Vacuum Tank truck (white). 3,300-gallon New Tank (red). New NVE 360 cfm pump. Clean Interior. Good Cold A/C. Air Ride/ Air Brakes (jake brake). DD15 Engine. 60% Rubber on tires. Mileage: 457,286. Price: \$70,000. 1-800-721-2774 (PBM)

New 4,000 U.S. gallon, aluminum, vacuum-pressure tank mounted on a 2023 Peterbilt 548 cab & chassis with NVE 4307 Blower Package. Stock #14006 **(888)VAC-UNIT (822-8648) www.vsrentalsllc.com. (PBM)**

Stainless steel 2010 Polar 3,600-gallon tank ready to mount on your chassis or sell outright. 20" rear manway, two 4" inch rear valves with full stainless hose trays. KLM Companies 617-909-9044 (PBM)

2001 Freightliner C-120 cab & chassis with a 2006 Presvac 3,200 U.S. gallon, C/S, dump type unit with a Presvac PV750 pump. (Stock #0480C). **www.vacuumsalesinc.com (888)VAC-UNIT (822-8648). (PBM)**

Pre-owned 1984 Mack R686ST cab and chassis with a 3,000 U.S. gallon, carbon steel, vacuum tank unit. (Stock # 6115C). **www.vacuumsalesinc.com (888)VAC-UNIT (822-8648) (PBM)**



**2007 international 2,500-gallon truck.** 250,000 miles. New rebuilt engine dt466. Automatic 6-speed. New liquid cooled how 400 masport. Tool boxes. **Excellent condition. New tires. 423-421-4347. (P10)**

1997 Peterbilt 378 cab & chassis with a Presvac 3,000 U.S. gallon, C/S, vacuum tank & Masport HXL15WV water cooled pump. (Stock #6625C). **www.vacuumsalesinc.com (888)VAC-UNIT (822-8648). (PBM)**

## SERVICE AND REPAIR

Dynamic Repairs - Inspection Camera Repairs: 48-hr. turn-around time. General Wire, Ratech, Ridgid, Hathorn, Electric Eel, Gator Cams, Insight Vision, Vision Intruders. Quality service on all brands. Rental equipment available. For more info. call Jack at 973-478-0893. Lodi, New Jersey. **www.dynamicrepairs.biz (PBM)**

**LIST YOUR EQUIPMENT**  
IN THE PAGES OF PUMPER!

**www.pumper.com/  
classifieds/place\_ad**



## SLIDE IN UNITS

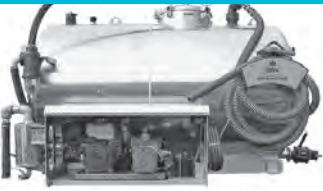

**Slide In Warehouse** has units available and ready to ship. Contact us today at 833-4-SLIDEIN (475-4334). 300-1500 gallon units. Complete, ready to work, units for your portable restroom, septic, or grease business. **Contact us today for pricing and availability. (P11)**

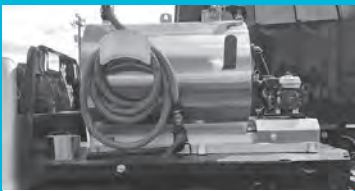

**NEW aluminum slide-in tanks.** 2 available. 450-gallon (300/150), Honda motors, Masport pumps. **Call JR @ 720-253-8014 or Mike @ 303-478-4796, CO. (PBM)**



**550-gallon steel slide in,** 100-gallon poly water tank. Masport HXL-3V vacuum pump w/9-HP Honda engine. 30' of 2" waste hose, 50' garden hose on hose reel. Toico water pump, 3" discharge. 7,000-lb GVWR tandem axle trailer. **\$16,029. Call Jamie 800-558-2945, salesinfo@imperialind.com. (PBM)**

## TANKS



**Xerxes 20,000 gallon fiberglass tank.** Approximately 15-18 years old. 10" diameter, 30' long. Has (3) 30" manways. Would be great for a Large Storage tank, under ground or above. Asking **\$10,000. Contact Brian 218-428-0391. Call or text. Delivery available. (P10)**



**Frac Tanks** from Geneva Equipment. Financing available! Delivered to your door! Perfect for: Portable sanitation storage; Dewatering; Wastewater storage and treatment; Hydroexcavation; Storm-water runoff. Geneva has over 1,000+ frac tanks available, epoxy lined and EPA compliant. **Call 855-202-7872 or sales@genevaequipment.com www.genevaequipment.com (PBM)**



**Any size tank can be custom built.** Slide-in tanks in all sizes. Plug and Play vacuum pumps are also available. **Call Rodney Lane 270-832-3793 for pricing. (PBM)**



**Complete Steel Vacuum Tanks** available 800-5,000-gallon. All prices are not the same. We deliver anywhere. **J Eagle Tanks 800-721-2774 www.jeagletanks.com (PBM)**



**One used steel vac tank 1,500/500** w/ Moro hydraulic AC4 vac pump. **Call JR @ 720-436-3910. CO (PBM)**



**Tanks in stock,** ready to ship out or let us install it for you. Restroom, septic, grease in stock with mounting kits. **Call 888-6VACTANK today! (PBM)**



**Used VAC Tanks.** 2500 to 4700-gallon - Starting at \$7,900. Gasco Triplex 3364-AL **269-751-5167. (PBM)**

## TOOLS

T&T Tools: Probes, Hooks. Probes feature steel shafts with threaded and hardened tips. The insulated Mighty Probe™ tested to 50,000 volts. Top Poppers™ open manhole covers easily. Free catalog. [www.tandt-tools.com](http://www.tandt-tools.com). Phone 800-521-6893. (PBM)

Crust Busters - Portable, lightweight machine guaranteed to mix up septic tanks and grease traps! Save time and money! [www.crustbusters.com](http://www.crustbusters.com), 1-888-878-2296. (PBM)

## TOYS

Septic pumper and vacuum die-cast toy trucks in your choice of colors and logos. Several cabs available. Call 877-450-2100, write to Granite State Collectibles, PO Box 440, New Ipswich, NH 03071; or [www.granitestatecollectibles.com](http://www.granitestatecollectibles.com). (PBM)

## TRAILERS



**6 units available for 2003, 12-foot Olympic Fiberglass Restroom Trailer.** In rentable condition as-is. Women's side is one open bathroom, a sink, & a mirror. Men's side has a toilet, a urinal, & a sink. Buyer is responsible for transport from New York. **\$5,000.00 - Call 800 634 2085 (P11)**

## TRAILERS-VACUUM/TANKER

Pre Owned 2006 Dragon 6,300 U.S. gallon, aluminum, vacuum tank trailer. Stock# 7980C [www.vacuumsalesinc.com](http://www.vacuumsalesinc.com) **(888)VAC-UNIT (822-8648) (PBM)**

Pre Owned 1999 Polar 6,400 U.S. gallon, aluminum, double conical, vacuum tank trailer. Stock# 2038C [www.vacuumsalesinc.com](http://www.vacuumsalesinc.com) **(888)VAC-UNIT (822-8648) (PBM)**

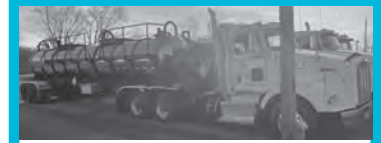

**2011 Kenworth T800 (\$70,000)** and a 1992 Presvac Tanker (\$40,000) (\$110,000 for COMBO) 12.9L L6 Diesel 455hp, 460k miles and 14k hours, 13 speed tran -- 5000 gallon DOT tanker with Liston Motor Vac Pump. **740-681-9902 (P10)**



**In stock, 6000- and 6300-gallon aluminum single-compartment Imperial vacuum trailers. Call Cory 800-558-2945 Ext. 426 (PBM)**

## TRUCKS (DUMP, SEPTIC, MISC.)



**2006 Peterbilt CAT C15 475HP,** 18-speed, 450,000 miles, 4,000-gallon aluminum tank, NVE 367 pump package, ready to work. **Call for pricing. (866) 720-4999. (PBM)**



**2011 international,** 2500 gallon vacuum truck, new jurop pump, and eagle tank, only 51,000 original miles, 466 with a 10 speed transmission, aluminum wheels, fresh build, available now, **\$89,500. Ernie- 619-454-9748 (P11)**

**Submit your classified ad online!**

[www.pumper.com/classifieds/place\\_ad](http://www.pumper.com/classifieds/place_ad)





**Brand New 2022 Grey 5500 Ram** with Black Interior. 300 miles on truck with a brand new Aluminum Tank with hose trays, low work station, dual inlets, dual cabinets. Power washer also included on tank. PTO driven vacuum pump with auto RPM, single vacuum hose, 3" discharge, 2 unit toilet hauler. \$119,500.00 Brand New Flowmark tank 1275 total capacity 900 gallon waste 375 freshwater. **TruWaste LLC: 573-745-7291 email: tru wastellc@gmail.com (P10)**



**2013 MACK Pinnacle Day Cab** Tractor MP8-505c, Jake brake, Eaton 13 sp transmission, A/R cab and suspension 14320 lbs frt, 38,000 lbs Rear, 220IN wheel base, wet kit excellent condition all around, 217,xxx miles, 8700 hours vin: 1M1AN07YXDM013662 2008 Dragon Vac Tanker, 150 Barrel (6300 gallons) Tandem axel Aluminum trailer NVE 600 cfm blower, runs off wet kit vin: 1UNST42239L068650 Selling as a combo, everything is in great condition and ready to work. **\$120,000 (Brian 218-428-0391) call or text - 30 more photos on request (P10)**

**Submit your classified ad online!**  
[www.pumper.com/classifieds/place\\_ad](http://www.pumper.com/classifieds/place_ad)



**2008 Freightliner M2112** Laurie Juggler truck tri-axle. Mercedes-Benz MBE 4000 410hp 4067 MT7E. Asking \$100,000. Mileage-107733.7 and Hours-9821.1. 3,000 gallon aluminum front tank and a 1,200 gallon rear tank. NVE957 blower package. Functioning recycle system. You can search YouTube using keywords Down's Septic to see a video. **You can contact Jay by email at [jwilhelm@thewilsoncomp.com](mailto:jwilhelm@thewilsoncomp.com). (P10)**



**Two Pump Trucks For Sale.** Both are International 550 HP Paystar Model 5600i with 5,000-gal capacity, Wittig RFL100 Pumps, 18-Speed Eaton Transmission, Axles: 20,000 Steerable, 22,000 Front, 46,000 Rear, Rearend ratio 4.3, Pre-emissions. -2003-328,887 miles \$52,500 -2004-149,552 miles **\$62,500. Contact Frank King 978 452-7750 (PBM)**



**2013 International**, 52,000 GVW, 270 HP, only 77,000 miles, equipped with NEW hydraulic set bed, 12,000 lb capacity. **\$64,000. Call Dewayne 256-338-4985. (PBM)**

## VACUUM EQUIPMENT



**2015 Kenworth T800** (\$280,000) ISX15 Cummins w/ 10 Speed trans, 61k miles, 4.3k hours, 3500 Gal DOT Tank, 700 Series Dresser Blower - 3627 CFM, PM80 Wet Pump. **Call 740-681-9901 for inquiries (P10)**

## VACUUM LOADERS

Pre Owned 1996 Kenworth T800 cab and chassis with a Super Products Supersucker, industrial vacuum loader. Stock# 2019C **[www.vacuumsalesinc.com](http://www.vacuumsalesinc.com) (888)VAC-UNIT (822-8648) (PBM)**

Pre Owned 2005 Kenworth T800 cab and chassis with a Super Products Supersucker, industrial vacuum loader. Stock# 5064C **[www.vacuumsalesinc.com](http://www.vacuumsalesinc.com) (888)VAC-UNIT (822-8648) (PBM)**

2022 Freightliner 114SD cab & chassis with a VACALL AV18 wet/dry Industrial, vacuum loader with 8" top load boom assembly. **[www.vacuumsalesinc.com](http://www.vacuumsalesinc.com) (888)VAC-UNIT (822-8648) (PBM)**

2000 Guzzler Ace International chassis with CAT engine. Great running truck and blower. Tank body was recently replaced brand new from Guzzler. KLM Companies 617-909-9044. (PBM)

## WANTED



## HIRING Portable Toilet Drivers

**Job description Pay \$21-\$23** Please email a clear picture of the front of your drivers license Work Base located at: Williston ND \*Job Type: Full-time \*Benefits: Dental insurance, Health insurance, Vision insurance. **Schedule: Monday to Friday Email [brianchilcott@hotmail.com](mailto:brianchilcott@hotmail.com) (P11)**



**GET  
EMAIL NEWS  
ALERTS FOR  
Pumper**

Go to  
[pumper.com/alerts](http://pumper.com/alerts)  
and get started today!



**FILL** *a job opening*  
**BID OUT** *an upcoming job*  
**ANNOUNCE** *contracted services offered*  
**SELL** *used equipment*  
**OBTAIN** *a position wanted*  
**FIND IT  
IN THE CLASSIFIEDS!**  
*In Pumper magazine and on the web. Pumper.com*



**DEDICATED  
TO THE LIQUID  
WASTE INDUSTRY.**

**Pumper**



# WHERE RELATIONSHIPS FLOW

It's been said that a little knowledge is dangerous. But what about a lot of knowledge? Like the chance to learn from the best in the business at nearly 100 live and online educational sessions. When applied to your business these ideas will help you kill it.

But there's more. A lot more. The WWETT Show is the world's largest annual trade show for wastewater and environmental service professionals offering live demos, multiple networking opportunities and an expo floor brimming with the latest technology and innovations in the industry.

**Be smart. Join us and thousands of your colleagues in Indianapolis for THE business event of the year.**

## SAVE THE DATE

### WWETT2023

CONFERENCE: FEBRUARY 20-23

EXPO HALL: FEBRUARY 21-23

INDIANA CONVENTION CENTER

WWETTSHOW.COM    



Proud member of:





# A WHOLE NEW BUYING EXPERIENCE

Imperial has expanded! We are proud to announce our new Truck Center! We have a new parking lot that can hold 200 trucks and a customer lounge, all conveniently contained in one place. When you come to pick up your truck, you will be directed to visit this new building!

Don't have an Imperial truck to pick up? Call our sales team, we have new truck chassis coming in that are ready to get outfitted with a tank and get to work!



[salesinfo@imperialind.com](mailto:salesinfo@imperialind.com)

1-800-558-2945  
[septictruckcenter.com](http://septictruckcenter.com) | [imperialind.com](http://imperialind.com)



**IMPERIAL  
INDUSTRIES INC**





# PRESVAC SYSTEMS

YOUR SINGLE SOURCE FOR MOBILE VACUUM SYSTEMS



## POWERVAC

- > 3250 US Gal. Carbon Steel Tank
- > 5300 CFM Blower
- > 8" Loading Boom
- > 10 GPM @ 4000 PSI Pressure Pump
- > PV750 Pressure Off Load Pump



## POWERVAC MINI

- > Two Compartment Aluminum Tank
- > 860 CFM Blower
- > 4" Loading Boom
- > 4200 USG Waste / 300 USG Water
- > 10 GPM @ 3000 Pressure Pump

**Established 1972**



4131 Morris Drive  
Burlington, Ontario, Canada L7L 5L5  
Fax: 905-681-0411

Nationwide Sales & Service

**800-387-7763 | 905-637-2353 | [www.presvac.com](http://www.presvac.com)**

**Quality...** is our Trademark