

DEDICATED TO THE LIQUID WASTE INDUSTRY

# Pumper

October 2010 www.pumper.com \$5.00 U.S.

The

## ROLLING STONES

Indiana family embraces industry innovation

PAGE 20

## A Youthful Outlook

Miller's Septic enjoys renewed enthusiasm

PAGE 30

PRSTD STD  
U.S. POSTAGE  
PAID  
COLE  
PUBLISHING



# "The New MD950 Breaks New Ground In Service Performance."

John Olson

*Original Designer of MD950*

## The MD950 Is Totally Redesigned With You In Mind

John should know, he designed the first MD950 in 1997 and it has become our best selling model. With reinforced skirting, greater visibility, more catwalk space, stronger cabinets and added strength and stability on the unit hauler, this truck will provide years of excellent service.

Take a moment and call your Area Manager or our Truck Specialists at **800-328-3332** to find out more about the incredible new MD950.

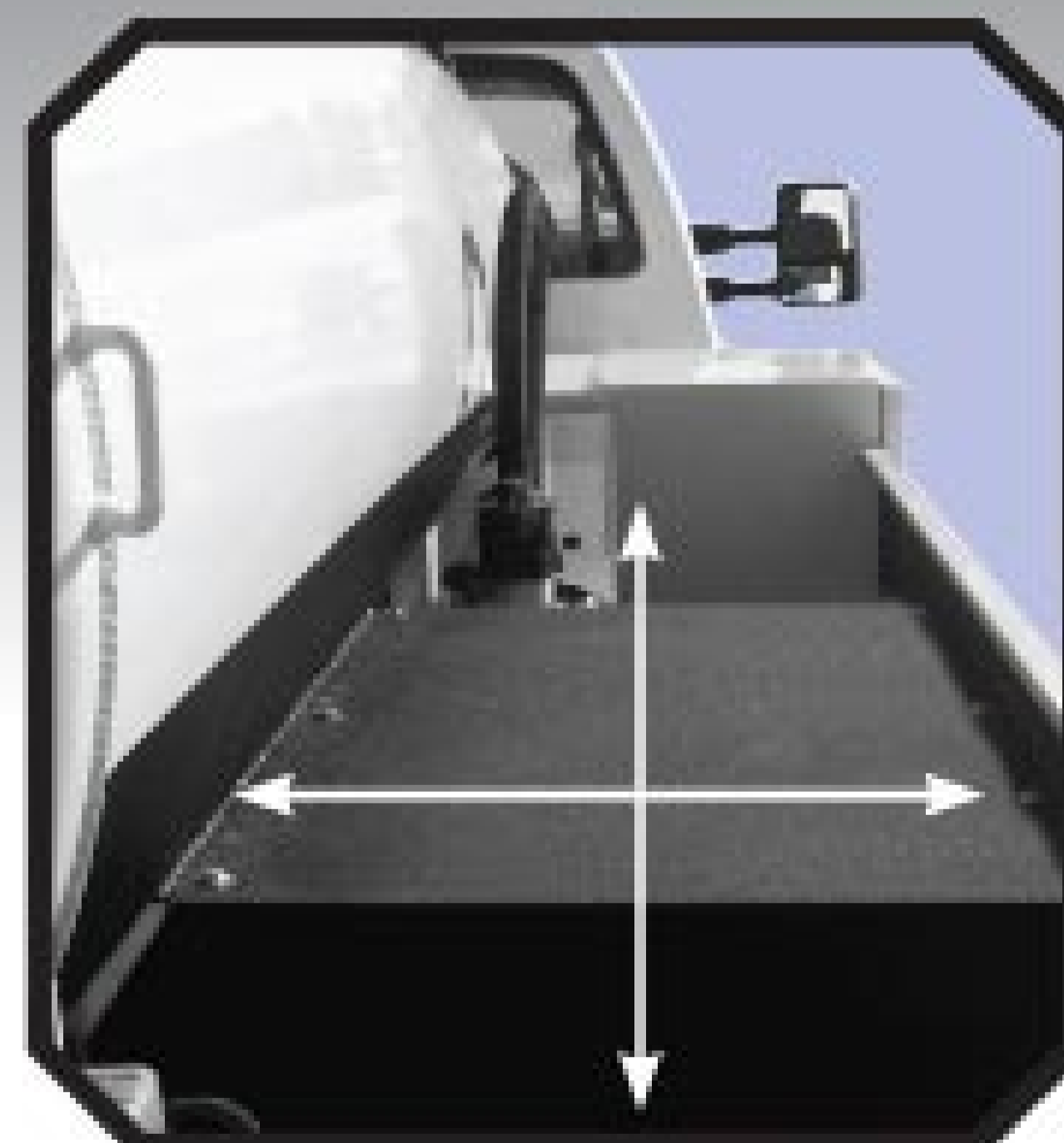

*Improvements include wider and longer hose trays, lower cabinets for increased visibility, a reinforced lift with added surface area and a stronger, reinforced frame.*

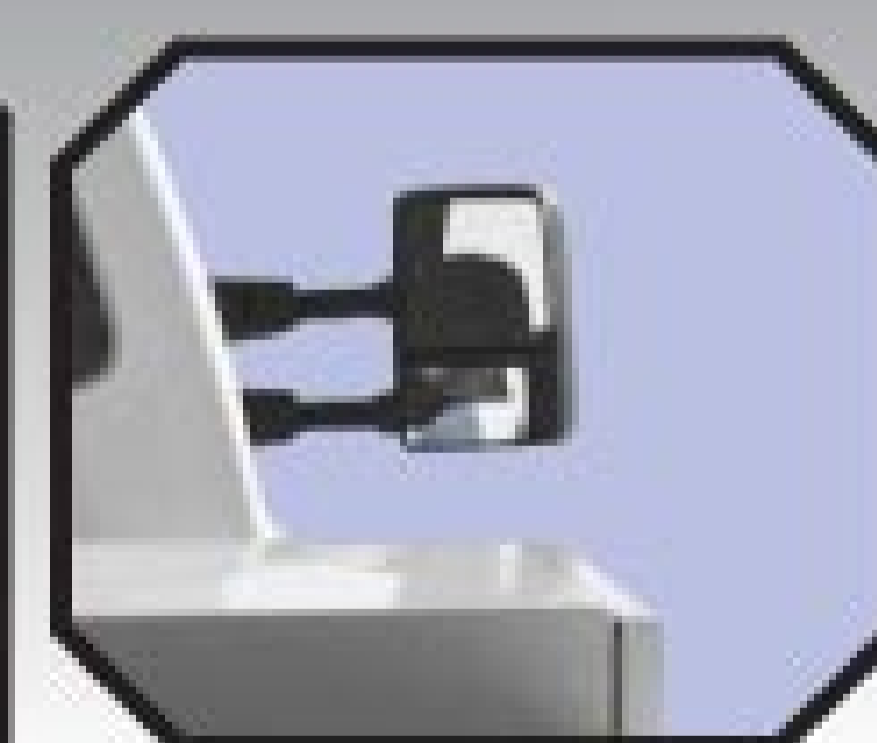

*Lower cabinets for increased visibility.*



**800-328-3332**

[www.satelliteindustries.com](http://www.satelliteindustries.com)

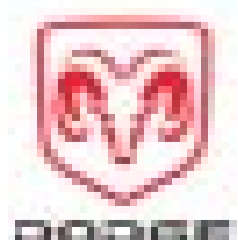

HXL400WV  
400 CFM



## Durable. Reliable. Powerful.

- Engineered for Fast Load Times & Optimum Recovery
- Liquid Cooled for Higher Continuous Vacuum
- Eliminate Freeze-ups in winter months

## Fast and Convenient

- Quick and Easy to Install
- Fully Assembled
- Includes: Scrubber, Gearbox, Inlet Filter, Base, Pump, Relief Valves, and Gauge

HXL400WV  
Plug & Play System



Clockwise & counter-clockwise rotations available. Please specify on your order.

**For more information  
call 1(800)228-4510**

**Visit us online  
[www.masportpump.com](http://www.masportpump.com)**

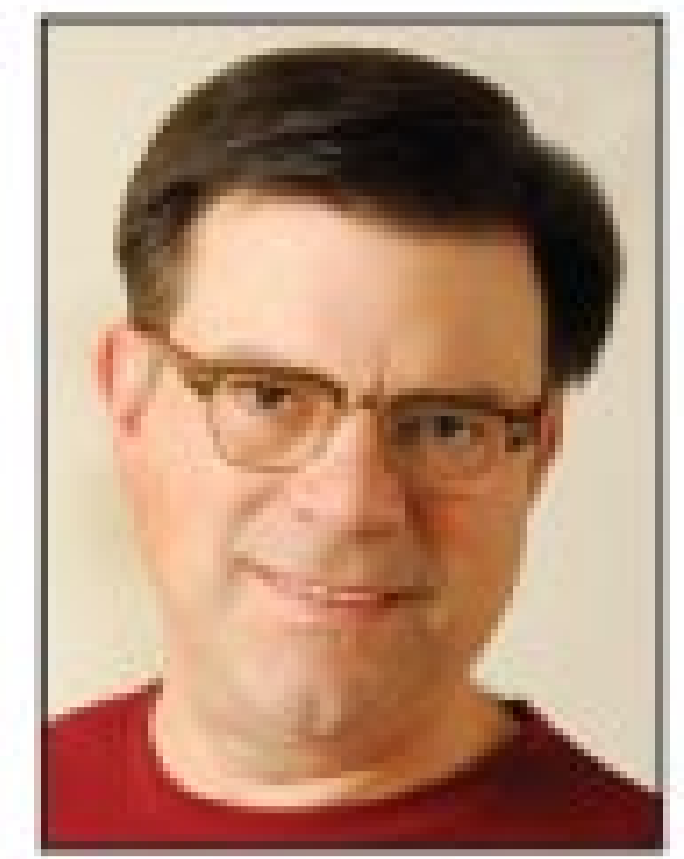

## For These Pumpers, Family Matters

By Jim Kneiszel, Editor

The contractor profiles this month remind me about the importance of family in keeping many pumping businesses chugging along. These contractors exemplify what a family business is all about ... teaching the next generation the trade, the boundless enthusiasm and new ideas of the younger people coming up, and continuing the thread of responsible business practices through the generations.

It's that cohesive bond of a multi-generational family business that leads to the dedicated workforce and loyal customer base that big corporations can only dream about. You'll not have any trouble finding someone to pitch in and help during a crisis when the next worker down the line is your son or daughter. They might complain a bit, but you can count on your flesh and blood coming in over the weekend when there's a backlog of work to be done.

So we celebrate those contractors lucky enough to have the support of mothers and fathers, sisters or brothers, sons or daughters. I enjoyed reading about the two families featured in this issue, and I hope they inspire you as well.

### THE ROLLING STONES

James Stone, the eldest son of Jay Stone of Stone Excavating in Plymouth, Ind., is grateful that he grew up taking lessons from Dad.

"My father did an excellent job teaching us that your word is your bond," James told writer **Scottie Dayton** in our cover story. "Even if you have to take a loss on something, it's better than tarnishing your honor. That philosophy has been very important to the success of our business and will remain so."

Jay Stone started the business in 1977, following in his father, **Harold's**, footsteps. Both men were an inspiration to the younger generation, which is taking on a stronger role in the business today.

"They worked hard for everything, and raised us with the same work ethic and to do our best," James says. "That kind of training makes a big difference in how we do business. It's not just about doing the job correctly and making a profit. It's about caring for people. If you're too busy to help them, then you've grown too big."

### IT'S MILLER TIME

The story is a little different for **Dave Miller** of **Miller's Septic Service** in Mauston, Wis. In business for 25 years, Miller was thinking about hanging up his hose when he became re-energized working with **Jason Graves**, the boyfriend of his 22-year-old daughter, **Kristin**. This past summer, the enthusiastic Graves took the wheel of one of Miller's septic rigs.

Just when Miller thought he wouldn't have a chance to pass along his industry knowledge to a family member, it looks like Graves might take over one day.

"Jason always says he's pumped, which gets me excited, too," Miller tells writer **Ken Wysocky** in our second profile ("A Youthful Outlook"). "It gives you a blast of energy again when someone's interested in what you're doing.

"As for down the road, who knows?" Miller says. "I don't want to put any pressure on him. Ideally, he'll take over the business. He really wants to run his own business. This business has provided a wonderful living for my family, and it just might do the same for him, too." ■

**Ask us** how the Sanitation Station can make you **money.**

~~Capital Outlay~~ =

**Sanitation Station** is a Commercial Quality Running Water Restroom great for construction projects that can:

- Boost your cash flow immediately
- Allow you to have no out-of-pocket expense
- Be moved throughout the jobsite to meet the manpower requirements
- We provide the Marketing Material & Sales Assistance

*Once these units are on the jobsite the revenue stream starts flowing...*

**DROP BOX** Custom Modification Specialist 888-388-7768 • 740-532-7822  
www.dropboxinc.com

**Lenzyme** Solutions for All Waste & Grease Problems

**NEW!** PRIVATE LABELED FREE! **ORDER NOW!**

Discover a **SWEET** idea

**GGW** Candy Marketing

**YOUR MARKETING PARTNER**

**BEST PACKAGING - BEST PRODUCTS - BEST PRICE**

Discover Marketing Secrets to More Pump-Outs

**1-800-223-3083**  
Call Today for Your **FREE** Sample

**ROOTX**

**Trap-Cleer** **Lenzyme**

# GET THE LAST OF THE PRE-EMISSION PETES AND INTERNATIONALS WHILE YOU CAN!



## 2011 PETERBILT 367

**\$137,900.00**

US Funds – FOB Buffalo, NY

*Many options available. Detailed specifications on request.*

- Caterpillar C13 (430 Hp) Pre-emission
- Fuller 8LL 10-speed
- 20,000 fronts 46,000 rears on air-ride
- Jake Brake - AM/FM/CD stereo
- Polished Everything! Power windows, locks & mirrors
- 4200 US gallon capacity
- TSI 500 pump (396 cfm) gearbox drive
- Two (2) 3/8" thick anti-surge baffles
- 20" top & rear man-way
- Heavy-duty stainless steel primary
- Polished aluminum toolbox
- 6" Discharge & 4" intake
- Five (5) 5" sight glasses
- Full-length hose trays.
- \* Lift axle Extra



**AUTOMATIC**

## 2011 INTERNATIONAL 7500

**\$116,900.00**

US Funds – FOB Buffalo, NY

*Many options available. Detailed specifications on request.*

- Automatic
- Maxxforce 10 (350 Hp & 1150 lb-ft)
- Allison 3000 RDS 6-speed automatic
- 18,000 lb front & 40,000 lb rears
- Air ride susp., factory air conditioning
- Polished Aluminum rims
- Full-locking differential
- 3600 US Gallon capacity
- TSI 500 pump (396 cfm)
- Two (2) 3/8" thick anti-surge baffles
- 20" top & rear man-way
- Heavy-duty stainless steel primary shut-off
- Polished aluminum toolbox
- 6" discharge & 4" intake
- Three (3) sight glasses or Sight tube
- Full-length hose trays



## 2011 INTERNATIONAL NAVISTAR 7500 AUTOMATIC

- Maxxforce 10 engine (350 Hp & 1150 lb-ft)
- 2010 Pre-emission engine
- Allison 3000 RDS 6-speed automatic
- 18,000 lb front 40,000 lb rears
- Air-ride suspension, factory air-conditioning
- Polished rims all around
- Full-locking differential
- 4000 US gallon capacity
- TSI 500 pump (396 cfm)
- 36" rear sideswing man-way
- 25 ton telescopic hydraulic hoist
- Garnett digital indicator
- 7" color LCD back up camera
- 20" top man-way
- Full diamond plate treatment all around
- Four sight glasses
- Polished aluminum toolbox- full length hose trays

**\$129,900 US FUNDS**

*AVAILABLE IMMEDIATELY*

**CUT OUT THE MIDDLE MAN – BUY DIRECT FROM THE MANUFACTURER**

**TRANSWAY**  
SYSTEMS INC.  
**PROFESSIONAL VACUUM EQUIPMENT**

**progress tank**  
DISTRIBUTOR

[www.transwaysystems.com](http://www.transwaysystems.com)

**Toll-Free 800-263-4508**

**Tel. (905) 578-1000**

**Fax (905) 561-9176**

DELIVERY SERVICE  
AVAILABLE

314 Lake Ave. North  
Hamilton, Ontario L8E 3A2

## ARTICLES

20

### Profile: The Rolling Stones

- Scottie Dayton

The busy Indiana father and sons team at Stone Excavating keeps moving forward to educate customers and keep pace with industry advances. **On the cover**, James Stone pumps a septic tank with his family's new International rig — featured at the 2010 Pumper & Cleaner Environmental Expo International — in the background. (Photo by Rusty Nixon)

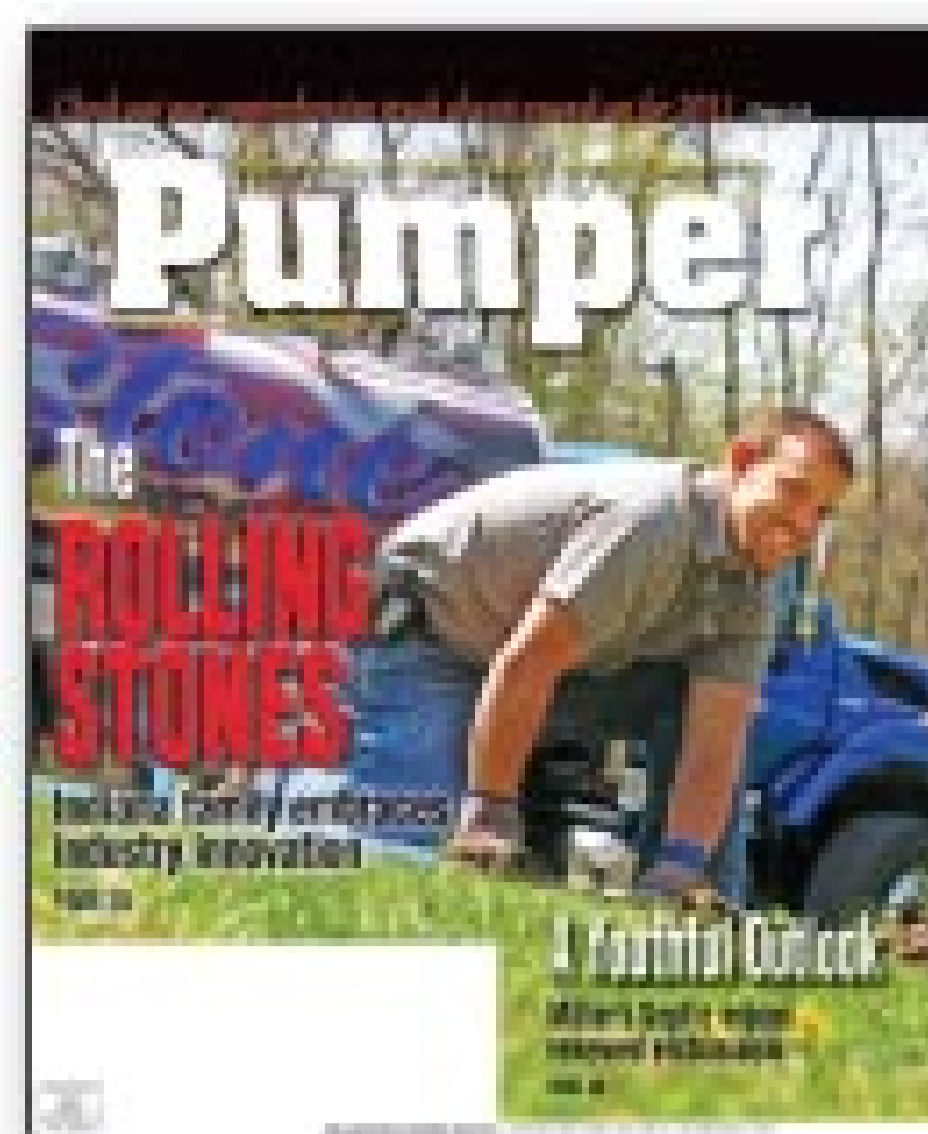

4

### Reading Between the Lines: For These Pumpers, Family Matters

- Jim Kneiszel

10

### Building the Business: Don't Stray From Path to Success

If you want to succeed in the small business game, you need to set specific targets and give workers incentives to hit them.

- George Hedley

14

### Rules and Regs: Tighter Restrictions, Looming Spreading Ban, Worry Florida Officials

- Scottie Dayton

30

### Profile: A Youthful Outlook

After 25 years in the industry, Wisconsin pumper David Miller figured he was moving toward retirement until an energetic assistant came along and ramped up his enthusiasm for the business.

- Ken Wysocky

38

### Pumper Interview: Promoting Portable Sanitation in India

Rajeev Kher utilizes American cleanliness standards and top industry technology to encourage portable restroom usage in a new frontier.

- Mary Shafer

46

### Overheard Online: Meter Reader

Faced with a problem customer, a pumper looks for an efficient way to track usage of a failing septic system.

54

### Truck Chassis Round-Up: Ready For Duty

When it comes time to update your pumping or other work truck fleet, cab and chassis manufacturers offer a variety of rigs to keep you rolling down the road.

- Ed Wodalski

## REGULAR FEATURES

60

### Money Manager: The 'S' Has It

When it's time to incorporate, the S corporation offers a number of advantages — and raises a few caution flags, too.

- Erik Gunn

66

### Reader Pipelines: Blocking Your Path to Profitability

Land application restrictions, low-ball competition and lax inspection and pumping regulations are among threats to business building.

- Mary Shafer

70

### Septic System Answer Man: Tank Troubles

Concrete septic tank construction practices are key to avoiding hydrogen sulfide deterioration.

- Roger E. Machmeier

76

### Classy Truck of the Month

We feature Mumford Services, North Kingstown, R.I.

80

### NAWT News: Join NAWT Training at 2011 Pumper & Cleaner Expo

- Tom Ferrero

86

### Industry News

92

### Product News In the Spotlight: Conde ProVac

96

### Association News; Training and Education; Calendar

## Coming in NOVEMBER

### SPECIAL ISSUE: Septic System Maintenance and Rejuvenation

- **Contractor Profile:** Washington State pumper keys on drainfield makeovers
- **Reader Pipelines:** Tougher system regulations mean business

# Pumper.

DEDICATED TO THE LIQUID WASTE INDUSTRY

[www.pumper.com](http://www.pumper.com)

Published monthly by

 COLE Publishing

COLE Publishing Inc.  
1720 Maple Lake Dam Rd.  
PO Box 220  
Three Lakes WI 54562

© Copyright 2010 COLE Publishing Inc.  
No part may be reproduced without permission of the publisher

In U.S. or Canada call toll-free 800-257-7222

Elsewhere call 715-546-3346

E-mail: [info@pumper.com](mailto:info@pumper.com)

Web site: <http://www.pumper.com>

Fax: 715-546-3786

Office hours 7:30 a.m. - 5:00 p.m. Central Time, Monday - Friday

**SUBSCRIPTION INFORMATION:** A one year (12 issue) subscription to *Pumper* in the contiguous 48 U.S. states costs \$16 (24 issues for \$26; 36 issues for \$36). Subscriptions to Canada or Mexico cost \$28 per year (24 issues for \$54). Subscriptions to all other foreign countries cost \$82 per year. Subscribers are guaranteed monthly delivery of the magazine. To subscribe, send company name, mailing address, phone number and check or money order (U.S. funds payable to COLE Publishing Inc.) to the address above. MasterCard, VISA and Discover are also accepted. Supply credit card information with your subscription order.

Our subscriber list is occasionally made available to carefully selected companies whose products or services may be of interest to you. Your privacy is important to us. If you prefer not to be a part of these lists, please contact Nicole at [nicole@colepublishing.com](mailto:nicole@colepublishing.com).

**CLASSIFIED ADVERTISING:** Rate: \$1 per word, per month. Minimum of 20 words or \$20. All classified advertising must be paid in advance. **DEADLINE:** Classified ads must be received by the first of the month for insertion in the next month's edition. **PHONE-IN ADS ARE NOT ACCEPTED.** Fax to 715-546-3786 only if charging to MasterCard, VISA, Discover or Amex. Include all credit card information and your phone number (with area code). Mail with check payable to COLE Publishing Inc. to the address above. **CLASSIFIED ADVERTISING APPEARS NATIONWIDE AND ON THE INTERNET.** Not responsible for errors beyond first insertion.

**DISPLAY ADVERTISING:** Call 800-994-7990 and ask for one of our sales staff listed below. Publisher reserves the right to reject advertising, which in its opinion is misleading, unfair or incompatible with the character of the publication.

#### OUR SALES STAFF:



Kim McGee



Jim Flory



Winnie May



Jim Koshuta



Kayla Wilkowi

**CIRCULATION:** Circulation averages 25,750 copies per month. This figure includes all circulation regions (nationwide) and international distribution.

## PUMPER & CLEANER ENVIRONMENTAL EXPO INTERNATIONAL



**Education Day:** March 2, 2011

**Exhibits Open:** March 3-5, 2011

Kentucky Exposition Center  
Louisville, Kentucky

[www.pumpershow.com](http://www.pumpershow.com)



# moro

# PUMPS

"Over 50 years of service and here to stay!"

412-253-6272 . fax 412-269-4172 . www.morousa.com . sales@morousa.com • 877-393-MORO (6676)

## MORO

## The Next Generation is Here!

+

- New Product Design
- Competitive Pricing
- Exceptional Service

## YOU

- Require Quality
- Require Service
- Can't Afford Down Time

=

- Less Pump Maintenance
- Fast Recovery Time = More Stops In A Year

## \$ YOUR BOTTOM LINE!

**BUY A BUNDLE PACKAGE AND SAVE EVEN MORE!**

**PM-A**  
Air-Cooled Pumps

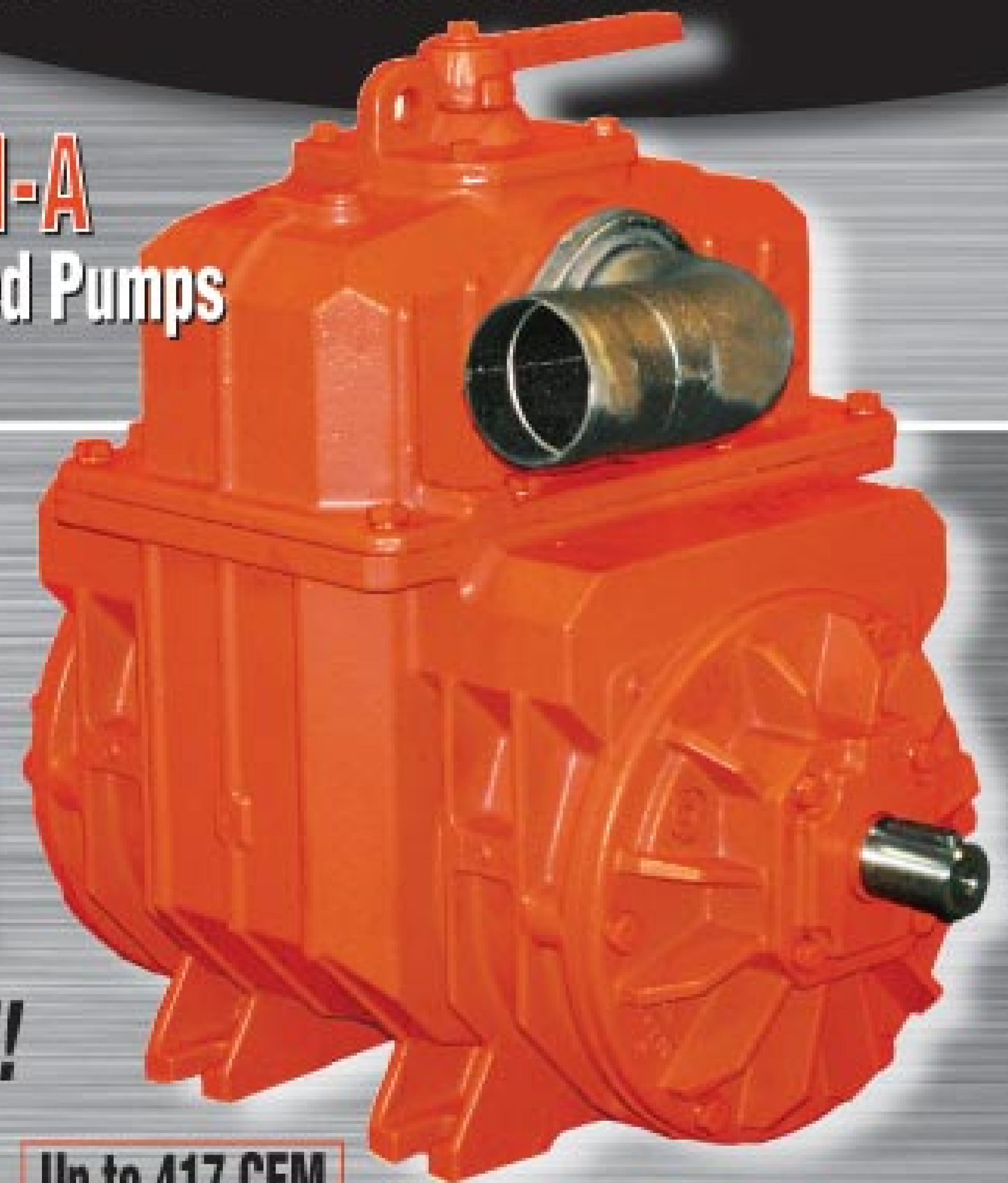

Up to 630 CFM  
Free Air Flow

**PM-W**  
Liquid-Cooled Pumps

Up to 417 CFM  
Free Air Flow



## BOUNTY PROGRAM

### WE'LL GIVE YOU UP TO \$500

### FOR ANY OTHER BRAND VACUUM PUMP!\*

### GIVE US A TRY — YOU WON'T BE DISAPPOINTED!

\* Limited time program. Offer good on PM-A and PM-W series only.



# ADVERTISER index .....

October 2010

## A

### ABBOTT RUBBER

Abbott Rubber Co. Inc. ....94

### ABERNETHY

Abernethy Welding & Repair .....16  
Accent Manufacturing .....40

### ACRO

Acro Trailer Company .....44  
Aero Tec Laboratories Inc. ....93  
Agribusiness .....108  
AlturMats Inc. ....18

### AMAZING MACHINERY

Amazing Machinery Inc. ....12

### AMT

American Machine & Tool Co. ....98  
Amthor International .....49  
Aqua Ben Corporation .....42



Aqua-Zyme Disposal Sys. ....74

### arcan

Arcan Enterprises Inc. ....106  
Arctic Blasters .....107

### ARMAL

ARMAL Inc. ....25

### ARMSTRONG EQUIPMENT INC.

Armstrong Equipment .....11  
Art's Truck & Equipment .....95

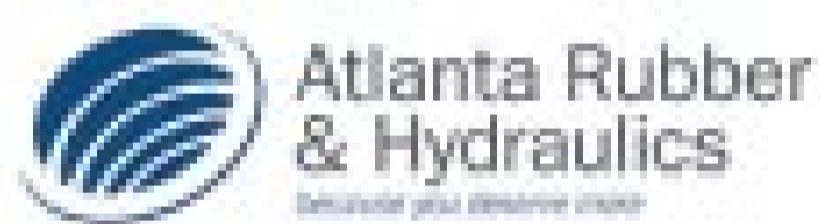

Atlanta Rubber & Hydraulics ....74  
Atlantic Dewatering Services ....98

## B

### Badger

Badger Vacuum Trucks .....18  
Balzer Inc. ....94  
Bandlock Corp. ....84  
BDP Industries Inc. ....83

### BEST ENTERPRISES

Best Enterprises Inc. ....27

### Seal-R

Brenlin Company Inc. ....95

## C

Cam Spray .....16  
Cape Cod Biochemical .....97



Capital Rubber Corp. ....42  
CC Roy Insurance Brokers Inc. ....42



Chandler Equipment Inc. ....9

### chempace

Chempace Corporation .....24, 78  
Clarus Environmental .....45

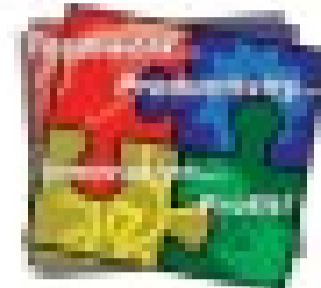

Clear Computing Inc. ....105

### Comforts of Home

Comforts of Home Services .....36  
Consolidated Pipe & Tube Co. 106



Crust Busters/Schmitz Bros. ....88  
Crystal Environmental .....106  
Custom Biologicals .....105  
Cyclops Electronics Inc. ....89

## D

D&W Diesel Inc. ....18  
Del Vel Chemical Co. ....88

### DROP BOX

DropBox Inc. ....4  
Dultmeier Sales .....88

## E



Ecological Laboratories Inc. ....68

### ELASTEK

AmericanMarine  
Elastec/American Marine .....58  
Elmira Machine Industries .....87  
EnviroTub .....78  
Erickson Tank & Pump .....90

## F

Fergus Power Pump Inc. ....56  
Five Peaks Technology .....77



Flo Trend Inc. ....12

### FRUITLAND

Tool & Manufacturing  
Fruitland Tool & Mfg. ....78

## G

GapVax Inc. ....61  
Garafano Tank Service .....107  
Giant Industries Inc. ....57  
Glendale Welding .....105  
GO FOR DIGGER .....90  
Granite Leasing Co. ....89  
Green Leaf Inc. ....91  
Green Way by PolyPortables .....67  
Guzzler Manufacturing Inc. ....75

## H



Hannay Reels .....56  
House of Imports .....72  
Hydra-Tech Pumps .....105  
Hydro-Action Manufacturing .....76

## I

Imperial Industries Inc. ....69  
Independent Truck Tank Inc. ....93

## J



J&J Chemical Company .....71  
Jack Doheny Supplies Inc. ....91



JAG Mobile Solutions Inc. ....68

## K

KeeVac Industries Inc. ....59



Kentucky Tank Inc. ....44  
KMH Equipment Co. ....86  
Kroy Industries .....48

## L

L.C. Tanks .....82  
L.M.T. Inc. ....40  
Lane's Vacuum Tank Inc. ....95  
Ledwell & Son .....52



Lely Manufacturing Inc. ....84

### Lenzyme

Lenzyme Inc./Trap-Clear .....4  
Liberty Pumps .....43  
Liquid Waste Industries Inc. ....98  
Longhorn Tank & Trailer Inc. ....28

## M



Marsh Industrial .....50

### Masport

Masport Inc. ....3  
McKee Technologies Inc./  
Explorer Trailers .....87  
Mid-Continent Truck Sales Inc. 108



Mid-State Tank Co. Inc. ....36

### Milwaukee Rubber Products, Inc.

Milwaukee Rubber Products .....26



Moro USA East Inc. ....7

## N

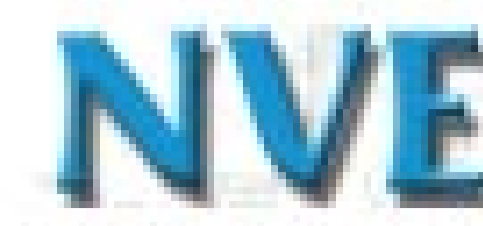

National Vacuum Equip. Inc. ....68  
NuConcepts .....16

### NUHN

Nuhn Industries LTD .....14

## P

Petersen Products Co. ....91  
Phoenix Industries & Apparatus .36



Pik Rite Inc. ....24  
PolyJohn Enterprises .....115  
Polylok Inc. ....114  
PolyPortables Inc. ....53  
Power Line Industries/  
Hot Jet USA .....24



Power Vac Inc. ....94, 95  
PowerFlo Products Inc. ....107  
Presby Environmental Inc. ....81

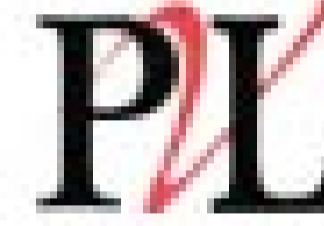

Pressure Lift Corp. ....90  
Presvac Systems Ltd. ....116  
Prototek Corporation .....40

## R

Reelcraft Industries Inc. ....26  
Ritam Technologies LP .....86  
Ritchie Bros. Auctioneers .....108  
Robinson Septic Service .....42  
RouteOptix Inc. ....82



Rush Refuse Systems .....65

## S

Safe-T-Fresh .....41  
Satellite Industries Inc. ....2, 63



Septic Services Inc. ....50  
Slide-In Warehouse .....59  
Smithco Mfg. Inc. ....64  
Spartan Tool LLC .....29  
Specialty B Sales .....89  
Stahly Applicators .....82  
Surco Products .....85

## T



T&T Tools Inc. ....62

### TankTec

Tank Technologies & Supply Co LLC  
TankTec .....47



Toico Industries Inc. ....64



Transport Truck Sales .....79



Transway Systems Inc. ....5  
Tri-State Tank .....62  
TSF Company Inc. ....73

### TUF-TITE

Tuf-Tite Inc. ....19

## V

Vac-Con Inc. ....17  
Vacutrux Limited .....87



VAR Co. ....15  
V.E. Enterprises Inc. ....72

### VIVAX METROTECH

Vivax-Metrotech Corp. ....58

## W



Walex Products Co. Inc. ....51  
Water Cannon Inc. ....37  
Webster Capital Finance Inc. ....48



Wee Engineer Inc. ....28  
Wells Cargo COG .....84



Westmoor Ltd/Conde .....13

Classifieds .....109  
Marketplace .....99  
Truck Stop .....102

### Midwest Supplement

(after page 82)

Advance Pump & Equip. ....3  
B<sup>2</sup> Business Brokers .....1  
Centrisys Centrifuge Sys. ....4  
Dave Syverson Truck Center .....2  
Heritage Truck Equipment .....6  
Liberty Financial Group .....2  
Marengo Fabricated Steel .....7  
Pat's Pump & Blower LLC .....4  
R.A. Ross N.E. ....6  
Rider Vacuum Sales .....8  
Sanitation Insurance Services .....8  
T-Line Equipment Inc. ....5  
V&H Inc. ....4

### Eastern Supplement

(after page 82)

Advance Pump & Equip. ....3  
Andert Inc. ....6  
B<sup>2</sup> Business Brokers .....1  
Centrisys Centrifuge Sys. ....4  
Crescent Tank Manufacturing ....2  
Heritage Truck Equipment .....6  
Liberty Financial Group .....2  
Manchester Hose & Coupling .....2  
Marengo Fabricated Steel .....7  
Pat's Pump & Blower LLC .....4  
R.A. Ross N.E. ....6  
Sanitation Insurance Services .....8  
TSI Tank Services Inc. ....8  
V&H Inc. ....4  
Vacuum Sales Inc. ....5





**Chandler  
Equipment, Inc.**

**1-800-342-0887**

[www.chandlerequipment.com](http://www.chandlerequipment.com)

MZ Valves are made from only the highest quality materials, and are available in the US exclusively from Chandler Equipment, Inc. Call Today for more information.



**With quality like this,  
you don't have to worry about a thing.**

**...except maybe your backswing.**



**METALTECNICA** s.r.l.

[www.metaltecnicazanolo.com](http://www.metaltecnicazanolo.com)



Ph **1-800-342-0887** | Fax **1-888-645-9700**

Visit our **NEW** website at [www.chandlerequipment.com](http://www.chandlerequipment.com)

**JUROP  
RV SERIES  
PUMPS**



available exclusively from **Chandler Equipment**



**Hi-efficiency dual fan air cooled  
24" Continuous Duty  
360 CFM & 520 CFM  
1200-1300 RPM Range  
Integrated 4-way Valve Manifold**

**RV520**

**RV360**

# Don't Stray From Path to Success

If you want to succeed in the small business game, you need to set specific targets and give workers incentives to hit them

By George Hedley

Leadership is simple. First, you've got to know exactly what you want — for your company. I speak to business owners and ask, "What do you want?" They respond, "I want to make a profit." I ask, "How much?" They answer, "As much as I can get." What if you can't get very much? "That's not enough." Then how much do you want? "More." More than what? "More than I'm getting now."

It becomes obvious they really don't know what they want or have a clear target to shoot for.

Examples of clear targets include: \$500,000 net profit per year; sales of \$1,000,000 per year. Leaders know what they want and communicate specific, clear targets and deadlines for their staff. And only then can you develop a plan to get what you want. More is never a target. More than what?

There are three steps to get what you want: 1. Know what you want. 2. Have a written plan. 3. Always track and make progress toward what you want.

You get pulled off track by day-to-day business activities. Things go wrong. Customers call with immediate needs. Equipment breaks. People don't show up. These daily inconveniences take you away from your No. 1 priority, which may be bottom-line profit, sales or customer service. You need a written plan to keep on track and measure your progress. I recommend written charts and graphs posted for all to see, clearly showing progress toward results.

### Keep targets clear and simple.

According to *Fortune* magazine, a top quality of America's most admired companies is laser-like focus. They have a clear, single business focus for what they're trying to accomplish. For example: Walmart — low prices, Nordstrom — customer service, General Electric — be No. 1 or 2 in every business they undertake. To me, that's not a path most small and medium business owners take. They try to do too much and be everything to everyone, instead of staying focused, doing what they do best, and only setting a few simple and attainable goals.

People and companies without clear written targets and goals are used by those who have established those targets and goals. It's very interesting. Those who have written goals achieve them. Those who don't get the leftovers. I always ask, "Have you got a measurable target? Do you have three clearly defined goals? What do you want to achieve this year?" In my survey of over 2,000 business owners, only 30 percent had written goals for sales, overhead and profit. No wonder companies struggle.

### Do you use scorecards?

Can you imagine playing a golf course without greens? Score doesn't matter. After four hours, you stop and go to the bar and start drink-

George Hedley, owner of Hardhat Presentations, is a business coach, speaker on business-building topics and author of *Everything Contractors Know About Making A Profit!* To reach him, call 800/851-8553 or visit [www.hardhatpresentations.com](http://www.hardhatpresentations.com).



People and companies without clear written targets and goals are used by those who have established those targets and goals ... Those who have written goals achieve them. Those who don't get the leftovers.

ing. There'd be no excitement. There's nothing to shoot for. No targets or scorecard. Sound bad? Sounds like most companies to me.

When you hit a bad golf shot, you can make the necessary adjustments to get back on course. In business, you've got different terrain and obstacles along the way to overcome as well. So you need information and feedback to make adjustments as you go, and targets to shoot for and a scorecard to keep track of progress. Get everyone involved by giving them clearly visible targets, written goals and a scorecard.

### Use challenges and incentives.

As a construction company owner, I am often amazed when I go out to a jobsite and ask the field superintendent, "When are you going to get this part of the project completed?" He says, "Well, I think we'll get it done in a couple of months." I then ask, "How did you come up with that completion date?" He then says, "Well, I talked to the subcontractor's job foremen and we sort of agreed we could all get it done by then."

Do you think you can finish it a week or two early? "Well, yeah, we probably could." Why don't you? "Well, there's no real need to. We're OK, we'll finish it on schedule." Wouldn't it be better to finish early? "Yeah, but it doesn't really matter that much, does it?"

As a leader, start challenging basic assumptions. Give people something to shoot for and a scorecard to track the progress. Offer competitive targets, challenges, and encouragements like: "If I give you \$100 for every day you finish early, do you think that might make a difference?" Then the response is: "Oh yeah, I know we can finish at least a week early, maybe even more."

### IN CLOSING

Leaders clearly lay out what is wanted, draft a blueprint to achieve it, and then watch the progress toward the goal. They also use incentives and challenges to get people focused to achieve the desired end results. When it's just the same old, same old — people give the minimum instead of their maximum effort. Everyone wants to be a part of a winning team. Lay out a path to victory and watch them hit a hole-in-one. ■

# NO COMPROMISE



**Masport**  
HXL400WV

**At Armstrong Equipment,** we believe life and business require certain compromises, but not on those things on which your business and family depend. A beautiful, new and shiny vacuum truck with a burned out pump is nothing more than uncomfortable transportation at four miles per gallon.

Your customers depend on you! Your employees depend on you! Your family depends on you!

We think you should be able to depend on **us!** That is why we sell the most dependable vacuum pumps, parts, valves and tank components available. When it comes to quality and reliability in the tools that make your business successful, there should be:

**"No Compromise."**

We proudly stock Masport, Jurop, NVE, Fruitland and G-D Wittig vacuum pumps, Sutorbilt blowers, Garnet Instruments SeeLevel gauges, Clearflow Heavy Duty valves and most other vacuum truck components and accessories. We can also provide replacement pumps and repair kits for most major brands. For more information call us toll free at **800-699-7557**.

## ARMSTRONG EQUIPMENT INC.

**800-699-7557**

11200 Greenstone Ave. • Santa Fe Springs, CA 90670

562-944-0404 • Fax: 562-944-3636

[www.vacpump.com](http://www.vacpump.com)

Hablamos Español



**FRUITLAND**  
RCF500F



**GD Wittig**  
RFL100



**GD Sutorbilt**  
4M



**NVE**  
506

**Juop**  
R260



# Dewatering Made Simple.



**Roll-Off**



**Poly-Mate®**



**Tipping Stand**



**Trailer Mounted**



Flo Trend® Systems  
707 Lehman St.  
Houston, TX 77018

800.762.9893

713.699.0152

Fax: 713.699.8054

sales@flotrend.com

From coast to coast the most economical and simple way to dewater municipal sludge. Do away with aging drying beds. Quit hauling water for disposal just because 1-2% are solids. Don't even consider complicated expensive and hard to maintain mechanical dewatering devices.

The Sludge Mate® together with the Poly-Mate® form a dynamic duo of dewatering. The Poly-Mate® conditions sludge through addition of polymer and the Sludge Mate® dewateres the flocculated sludge.



## Locators

512 Hz

Only

**\$895**

Plus

Leak Detectors  
Split Box Locators  
Transmitters

## Cameras

As Low As

**\$399**

36 Models To  
Choose From



Video  
Online

## Conversion Kits

**\$279**

Convert A  
Pressure  
Washer  
To A Jetter



No Compromise  
Best Service/Best Price

**AMAZING  
MACHINERY**

Your Equipment SUPERSTORE Since 1995

Celebrating 15 years

**1-800-504-7435**

Complete Details At

[www.AmazingMachinery.com](http://www.AmazingMachinery.com)

2288 Gunbarrel Rd, Ste. 111-151 • Chattanooga, TN 37421

## Jetters

Starting At

**\$8695**

Up To 4000 psi  
& 22 gpm



Starting At

**\$1499**

Up to 4000 psi  
& 12 gpm



## Jetter Hose Sale

1/8" Hose: 50' \$39.95 / 100' \$64.95

1/4" Hose: 100' \$89.95 / 200' \$169.95

3/8" Hose: 150' \$199.95 / 250' \$329.95

1/2" Hose: 200' \$409.95 / 400' \$689.95

## Cable Machines

**\$419**

1/3 hp



**\$1499**

3/4 hp

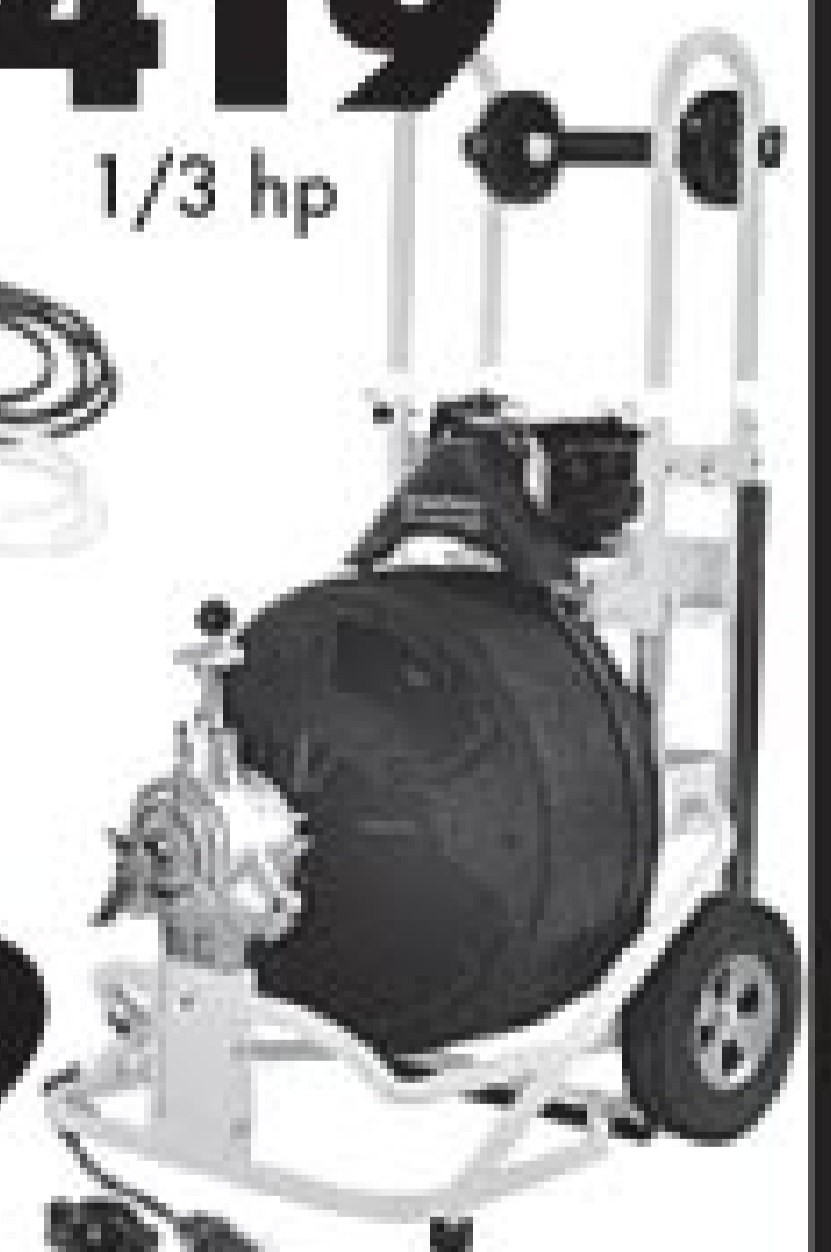

## Jetter Nozzles

From

**\$16.95**

Custom Drilled 2-25 Orifices



**Generators / Air Compressors / Pressure Washers / Trash Pumps**





**DURABLE Equipment DESIGNED  
Specifically for your NEEDS!**

**2.95%  
Financing  
36 Months  
OAC to USA  
Customers**



**MAGNUM  
600 Vacuum Pump**

For Pump Dealer Inquiries

**519-393-6284**



**For Closest Dealer: (877) 837-7323**  
For Demonstration go to: [www.nuhn.ca](http://www.nuhn.ca)

**Come In We're**  
**OPEN**  
[www.pumper.com](http://www.pumper.com)

## Rules and Regs

By **Scottie Dayton**

*Rules and Regs is a monthly feature in Pumper. We welcome information about state or local regulations of potential broad interest to onsite contractors. Send ideas to [editor@pumper.com](mailto:editor@pumper.com).*

# Tighter Restrictions, Looming Spreading Ban Worry Florida Officials

**A**s of July, the state septic code required all 2.6 million onsite systems to be inspected and pumped every five years. The state has estimated that one in 10 septic tanks are failing and expected about 260,000 to be replaced by 2020.

Health officials, however, are concerned about what to do with septage pumped from those systems, since the state's new water supply legislation bans land application of septage in 2016.

Because of the legislation, Marion County commissioners repealed sections of the Springs Protection Ordinance. They rescinded provisions requiring tanks to be inspected every five years and failing systems to be replaced with low-dosing systems.

Replacement systems must now have a 24-inch separation between the drainfield trenches and the water table. Since the county land-applies septage, health department officials must submit a septage management report to the legislature by February. They are considering a mandate providing incentives for private waste-processing plants to increase their disposal capacity.

Replacement systems must now have a 24-inch separation between the drainfield trenches and the water table.

### NEW MEXICO

Socorro County is utilizing the American Recovery and Reinvestment Act and USDA Rural Development funds to replace onsite systems with sewer service for homes in the Middle Rio Grande watershed.

The state Department of Environmental Quality categorized the area as impaired based on levels of E. coli bacteria traced to onsite systems. The agency also requires systems to pass an inspection before property transfers.

### CALIFORNIA

The state Assembly amended a bill that would prevent non-dispersible or poorly dispersible products from entering sewer or onsite systems and potentially causing overflows. The rule would enable consumers to identify which products are safe to dispose of via the plumbing system, and update the guidance criteria for flushability published by the Association of the Nonwoven Fabrics Industry to reflect new plumbing, onsite, and sewage technologies. If passed, the law would take effect Jan. 1, 2012. ■



# SPOOKY DEALS!

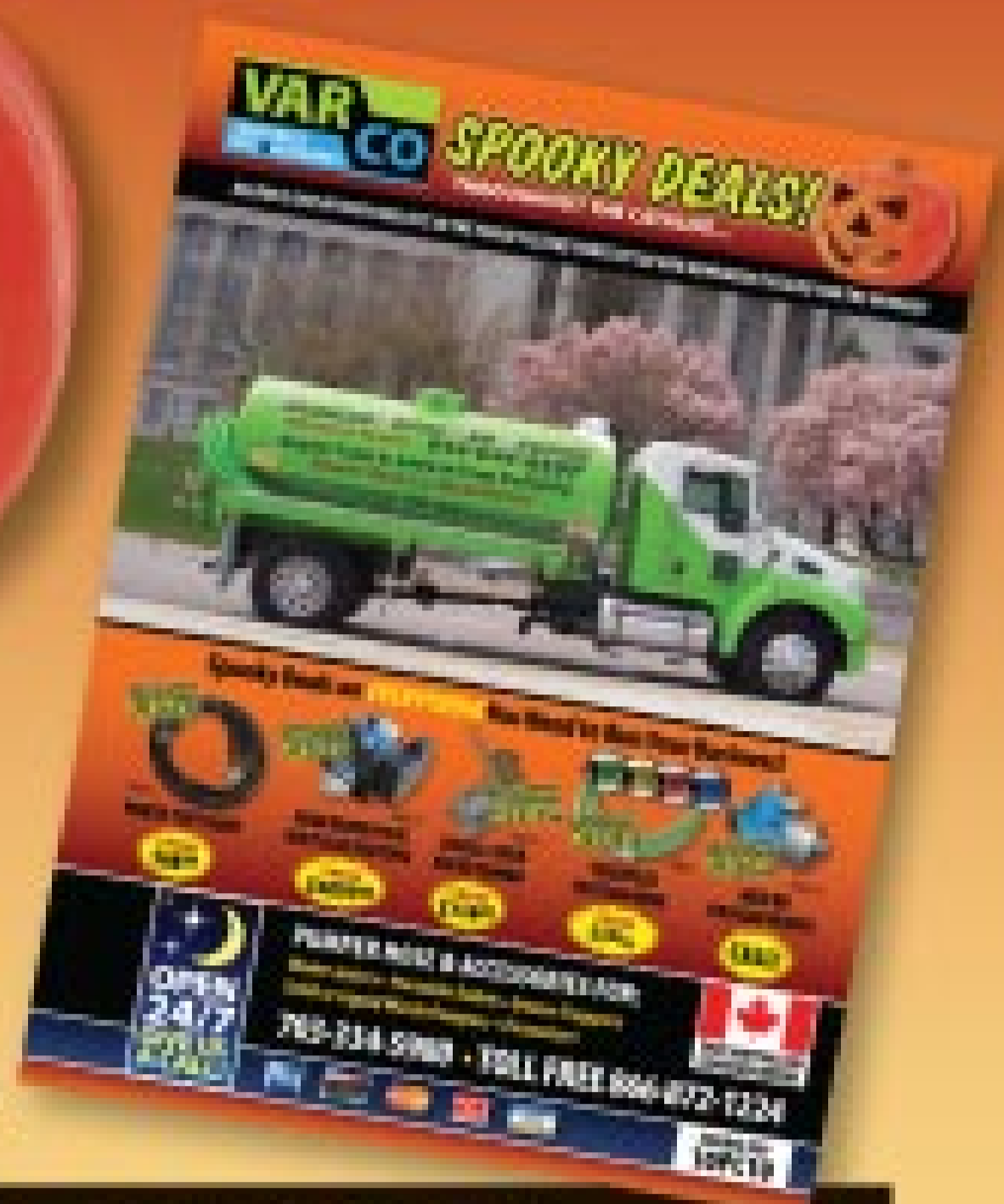

## HOSE HEADQUARTERS

HOSE COLORS THAT MATCH YOUR TRUCK!

BLUE AND BLACK

RED AND BLACK



CALL FOR A FREE CATALOG!



WE DON'T CHARGE EXTRA FOR COLORS LIKE SOME DO!

BUY IN BULK AND SAVE MONEY!

SPOOKY DEAL!



SPOOKY DEAL!

INCLUDES FITTINGS!

### EPDM SUCTION BULK 100 FT ROLLS

2"	3"	4"	6"
<del>\$2.19</del>	<del>\$3.69</del>	<del>\$6.59</del>	<del>\$11.35</del>
\$1.69 ft	\$2.85 ft	\$5.35 ft	\$10.25 ft

### EPDM SUCTION COUPLED MXF QUICK CONNECT

3" X 20'	3" X 25'	3" X 30'	3" X 33'
<del>\$84.00</del>	<del>\$99.00</del>	<del>\$114.00</del>	<del>\$123.00</del>
\$83.28	\$96.76	\$113.49	\$125.93

## PORTABLE TOILET HOSE



SPOOKY DEAL!

INCLUDES FITTINGS!

### TIGER TAIL COUPLED MXF QUICK CONNECT

2" X 25'	2" X 30'	2" X 35'	2" X 40'
<del>\$99.75</del>	<del>\$113.00</del>	<del>\$129.75</del>	<del>\$145.50</del>
\$84.95	\$99.95	\$117.95	\$131.95



SPOOKY DEAL!

A VARCO EXCLUSIVE!

NO CUFFS! LIGHTWEIGHT! OUR MOST FLEXIBLE HOSE!

### PORTA-TUFF HOSE COUPLED MXF QUICK CONNECT

2" X 25'	2" X 30'	2" X 35'	2" X 40'
<del>\$91.70</del>	<del>\$108.70</del>	<del>\$125.45</del>	<del>\$142.40</del>
\$84.95	\$99.95	\$117.95	\$131.95

## PRICES SO LOW ON VACUUM PUMPS WE'VE SPOOKED THE COMPETITION!

### Jurop VACUUM PUMPS- WE GOT 'EM!



### A COMPLETE BOLT & GO SYSTEM FOR ONE LOWPRICE!



FREE SHIPPING!

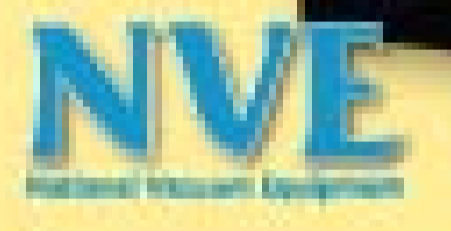

**MEC 11000 MAX PACK**  
394 cfm pump, oil catch muffler, secondary, final filter, gauge, vacuum relief and pressure relief valves- right angle gearbox and auto align bracket all mounted in a powder coated pump stand- just bolt it on your truck & go!  
**ONLY \$4,895<sup>00</sup>**  
INCLUDES FREE SHIPPING



WE GOT 'EM!  
Price So Low We Can't Print It!  
CALL FOR PRICE

### COUPLE-IT-YOURSELF STARTER PACKAGE

- CENTER PUNCH TOOL
- 50 CLAMPS TO FIT 3" - 4" HOSE



SPOOKY DEAL!

LOW PRICE \$69<sup>95</sup> pkg.

TOOL ONLY \$44.95

### BATTIONI VACUUM PUMPS WE GOT 'EM!



BATTIONI PUMPS STARTING AT

DRIP LUBE \$1,381.94 **\$1,224<sup>00</sup>**  
AUTO LUBE \$1,581.69 **\$1,400<sup>55</sup>**

### FOR 2,500-6,000+ GAL. TANK 320 CFM



**MEC9000**  
Continuous Duty - Ballast Port Cooled  
~~\$2590.00~~ **\$2,395<sup>00</sup>**

### FOR 2,500-6,000+ GAL. TANK 394 CFM



**MEC11000**  
Continuous Duty - Ballast Port Cooled  
~~\$2910.00~~ **\$2,675<sup>00</sup>**

## WE HAVE REBUILD KITS AND PARTS FOR CHALLENGER, MORO, JUROP & BATTIONI PUMPS



SPOOKY DEAL!

BRASS LEVER VALVES  
3" \$95.00  
4" \$132.00  
6" \$245.00



SPOOKY DEAL!

BRASS LEVER VALVE COMBOS  
Includes Lever Valve, Type "F" Male Adapter by Male Thread and Dust Cap.  
3" \$104.00  
4" \$145.00  
6" \$285.00



RV PUMP OUT KIT  
WITHOUT HANDLE \$99.95  
WITH HANDLE \$119.95

CALL TO ORDER TOLL FREE 866-872-1224 • www.varcopumper.com

SOURCE KEY 10P10

# ABERNETHY

WELDING & REPAIR INC.

1.800.545.0324

abernethyinc@charterinternet.com

Financing Available  
authorized distributor for:

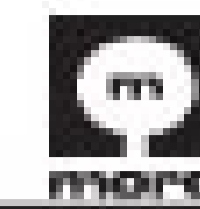

NVE

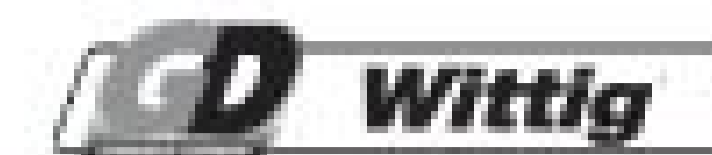

Masport



2010 Peterbilt, auto trans, 26000 GVW, AC, 1500 gallon portable service unit, HXL75V Masport pump.



2010 International 4400E Series, 260 hp diesel DT 466 engine, 6-spd. trans. and world class auto, air brakes, 33,000 GVW, A/C, 2500 gal. tank, Masport HXL400 pump Also, 2500 and 3500 gal. tanks

## Ford • KW • International

### 2-2010 INTERNATIONAL

2500 gal. tank

### 2010 PETERBILT

2500 gal. tank

### NEW PORTABLE

### TOILET UNITS:

### 2-2009 INTERNATIONAL 4300

1500 gal. portable toilet service units, auto trans.

### WE WILL CUSTOM BUILD YOUR TANK UP TO 5000 GALLONS!

600-1500 Gallon Portable Toilet Trucks: Our Truck or Yours

### PORTABLE TOILET UNITS:

- 2004 Chevrolet 3500 - Flat bed, lift gate, Portable Restroom Hauler
- 1999 Internat'l 4700 - 1100/400 gal. tank, good condition
- 1999 Sterling - 1500 gal.
- 1995 UD - 1000 gal. tank

### SEVERAL GOOD, OLDER TRUCKS TO CHOOSE FROM:

- 1999 Volvo - 5000 gal. tank, 350 cfm pump
- 1995 Chevrolet - 1 800 gal. tank, gas, under CDL
- 1995 International - 2200 gal. tank
- 1990 Chevrolet - 2000 gal. tank

MANY OTHER UNITS IN STOCK!  
CALL FOR UPDATE

TRUCK  
REFURBISHING  
AVAILABLE

### COMPLETE PARTS AND IN-HOUSE SERVICE

Cook Compression Vanes • Moro • Battioni • Jurop • Masport  
Fruitland • NVE • Powerflo • Plus many other brands

[www.abernethywelding.com](http://www.abernethywelding.com)



## The New Model SK4018DT

4000 psi,  
18 gpm  
Hydraulic Reel  
66 h.p. Diesel



See our complete lineup including Hot Water models, van mounts, portables and more on the web at:

[www.camspray.com](http://www.camspray.com) 800-648-5011

## NUCONCEPTS

MANUFACTURER OF QUALITY PORTABLE RESTROOMS AND SINKS



### Dual VIP Restroom Trailer

From \$9,841

#### Ideal for:

- Weddings / Parties
- Sporting Events
- Food Festivals
- Community Events
- Restroom Remodeling
- Movie Production

#### Features:

- Solar Powered
- Self-contained
- Flushing, china toilet
- Enclosed sink
- Power Converter (option)
- Air-conditioning (option)
- Interior Heater (option)
- Sink Water Heater (option)



1737 S. VINEYARD AVENUE • ONTARIO, CA 91761  
PHONE 909-930-6244 • TOLL FREE 800-334-1065 • FAX 909-930-6237  
[www.NUCONCEPTS.COM](http://www.NUCONCEPTS.COM)





# VAC-CON

## PRE-OWNED EQUIPMENT

### MORE POWER TO YOU



**2005 VAC-CON V321LHAD**

- 2005 IH 7600
- CAT C-13 380 HP / 10-SPD
- 50 @ 3000 / DEUTZ 138 HP
- Mileage: 31,000

**\$195,500**



**2000 VAC-CON V312LHA/1300**

- 2000 STERLING LT7501
- 275HP / Allison MD3060
- 60 @ 2000 / Cummins B3.9
- Mileage: 45,950

**SOLD**



**2004 VAC-CON V312SHA**

- 2004 Sterling LT7501
- CAT 275 HP / Allison MD3060
- 80 @ 2000 / DEUTZ 138 HP
- Mileage: 41,000

**RECONDITIONED \$185,000**



**2006 VAC-CON VPD4212LHAE**

- 2006 IH 7400
- IH 285 HP / Allison 3000RDS
- 80 @ 2000 / DEUTZ 138 HP
- Mileage: 82,000km

**RECONDITIONED \$205,000**



**2006 VAC-CON V312LHAD**

- 2007 STERLING LT7501
- CAT 275 HP / Allison 3000RDS
- 50 @ 3000 / DEUTZ 138 HP
- Mileage: 23,000

**\$209,500**



**2000 VAC-CON VPD3609SHA**

- 2001 IH 2654
- 275 HP / Allison MD3060
- 60 @ 2000 / John Deere 4045T
- Mileage: Approx 45,000

**\$145,000**



**2001 VAC-CON V312LHAD/1300**

- 2001 Sterling LT9501
- CAT 380 HP / 10-Speed
- 80 @ 2000 / Cummins 110 HP
- Mileage: 73,000

**RECONDITIONED \$185,000**



**2004 VAC-CON V311LHAD**

- 2004 Sterling LT7501
- CAT 275 HP / Allison MD3060
- 65 @ 3000 / DEUTZ 138 HP
- Mileage: 88,200

**RECONDITIONED \$195,000**



**2001 VAC-CON VPD3611SHA/1300**

- 2002 INTERNATIONAL 2654
- 275 HP / ALLISON MD3060
- 60 @ 2000 / CUMMINS B3.9
- Mileage: 33,000

**RECONDITIONED \$165,000**



Ultimate Lease Hotline:  
**888-817-1757**

969 Hall Park Drive • Green Cove Springs, FL 32043 U.S.A.

Tel: 904-284-4200 • Fax: 904-284-3305

www.vac-con.com • vns@vac-con.com



Remanufactured  
Vacuum Pumps  
and Blowers -  
Save Up To \$2,000



—We rebuild all makes—

## QAA:

- § **Quality** – D&W offers quality products, adheres to strict quality procedures and stands behind those products with an industry leading warranty.
- § **Affordability** – Remanufactured and repaired units offer significant savings compared to new – up to 60%!
- § **Availability** – On the shelf exchange inventory of remanufactured vacuum pumps available for same day shipping.

Contact D&W to  
arrange for FREE pick up of your  
vacuum pump or blower

**888-858-1188**

[dwdiesel.com](http://dwdiesel.com)

[marketing@dwdiesel.com](mailto:marketing@dwdiesel.com)

§ Auburn, NY § Albany, NY § Rochester, NY § Buffalo, NY § Worcester, MA § Cleveland, OH

# Built Tough. Guaranteed.

**6  
YEAR  
Guarantee**

## AlturMATs Turf Protection Mats

- Saves turf repair costs due to vehicle damage
- 1/2" thick polyethylene
- Bold tread design
- Sizes to 4' x 8'
- Leaves turf smooth...no ruts or torn up lawns
- Withstand 60 tons
- Reuse hundreds of times

**AlturMAT.**

701 East Spring St., Mailbox 9 • Trusville, PA 16354  
[sales@alturmats.com](mailto:sales@alturmats.com)

[www.alturmats.com](http://www.alturmats.com)

Plywood's out...AlturMATs are in!  
Call for the name of your nearby dealer:

**888-544-6287**



**KNOW-HOW  
TO GET YOU  
MOVING**

Now In **STOCK!**

**VACUUM TRUCKS**  
Stainless Steel Tank

2010 International 7500, 3600 Stainless Steel, 500 CFM pump, 350 HP,  
Automatic trans., 18K front, 40K rear air ride.

**\$127,000 Plus FET**

**3600 GALLON  
STAINLESS  
STEEL**

We Have Financing  
Available!

Call Us Today Toll-Free:  
**888-201-9166**

[www.badgertruck.com](http://www.badgertruck.com)

Septic - Portable Toilet -  
Hoisted Vacuum - Slide-Ins  
New Units Available / Trade-ins Accepted!  
Financing & Lease Plans



# 24" HEAVY DUTY MULTI-PURPOSE FLAT RISER LID

**FREE FREIGHT  
 on Full Cartons!**

**Fits most commercially  
 available:**

- Risers
- IPEX PVC Ribbed Pipe
- Corrugated Pipe

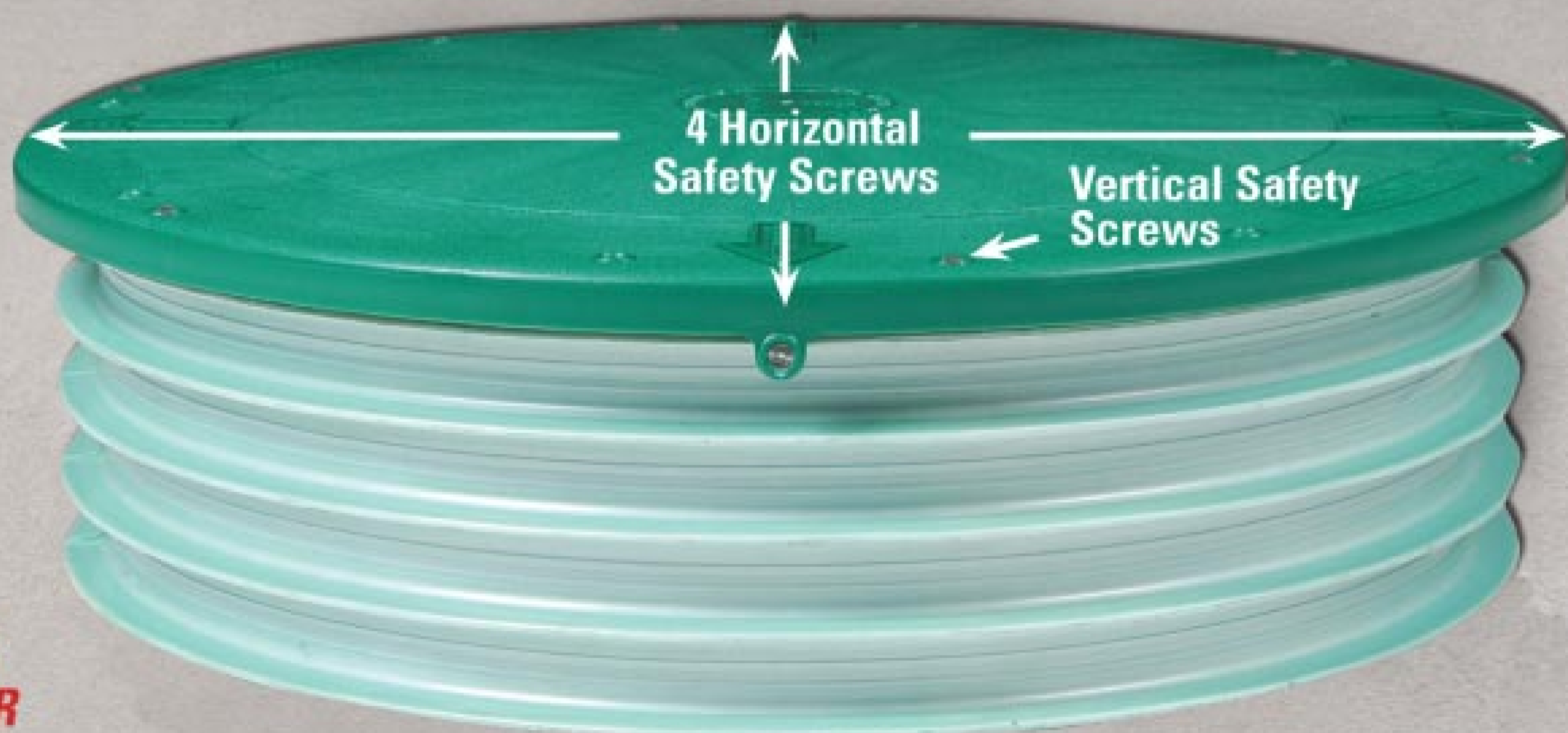

**LID MAY BE USED WITH OR  
 WITHOUT CONCRETE CENTER**



Secured by 6 Vertical and 4 Horizontal Safety Screws. Screws Included.

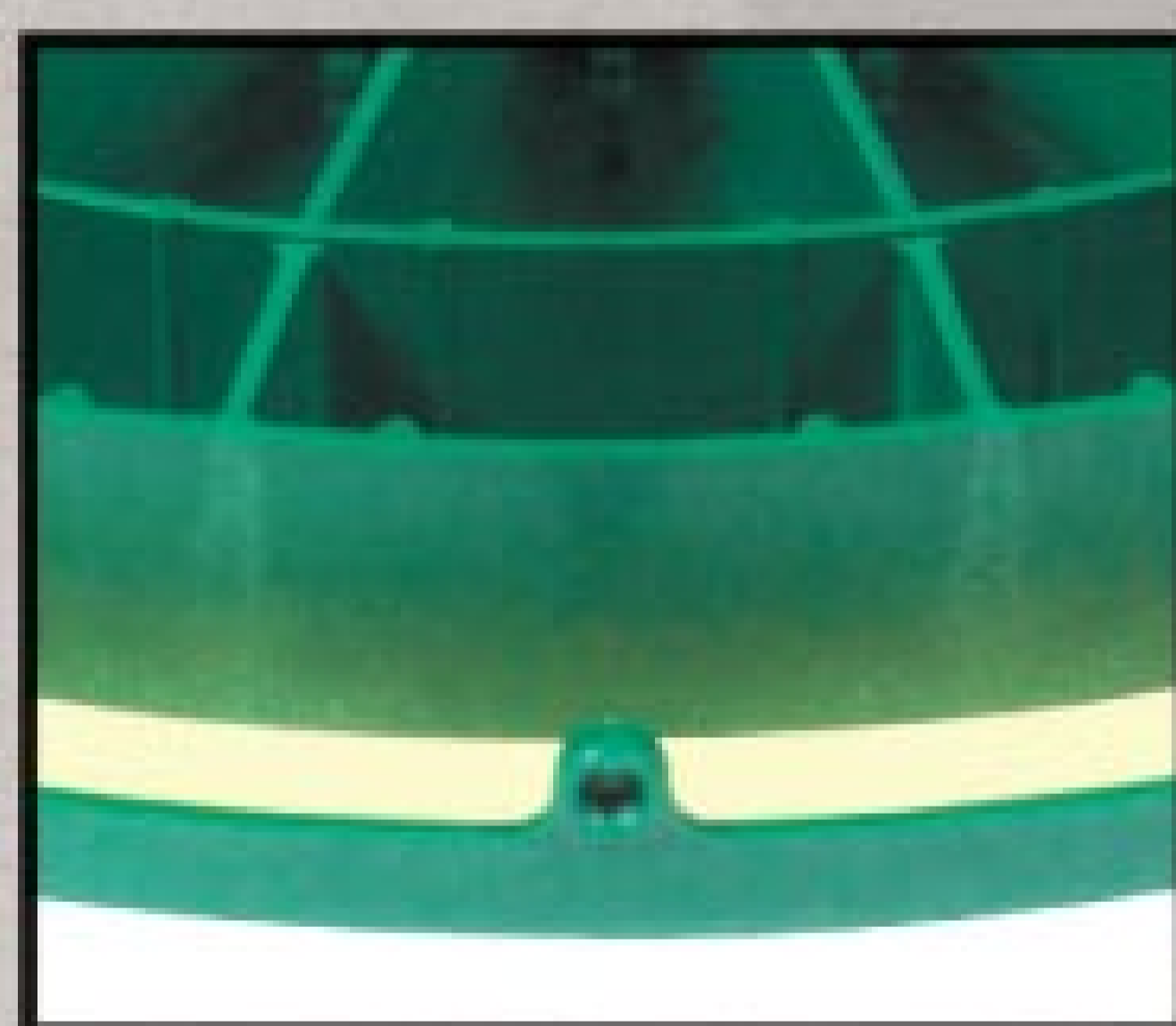

Foamed-in Permanent Polyurethane Gasket.

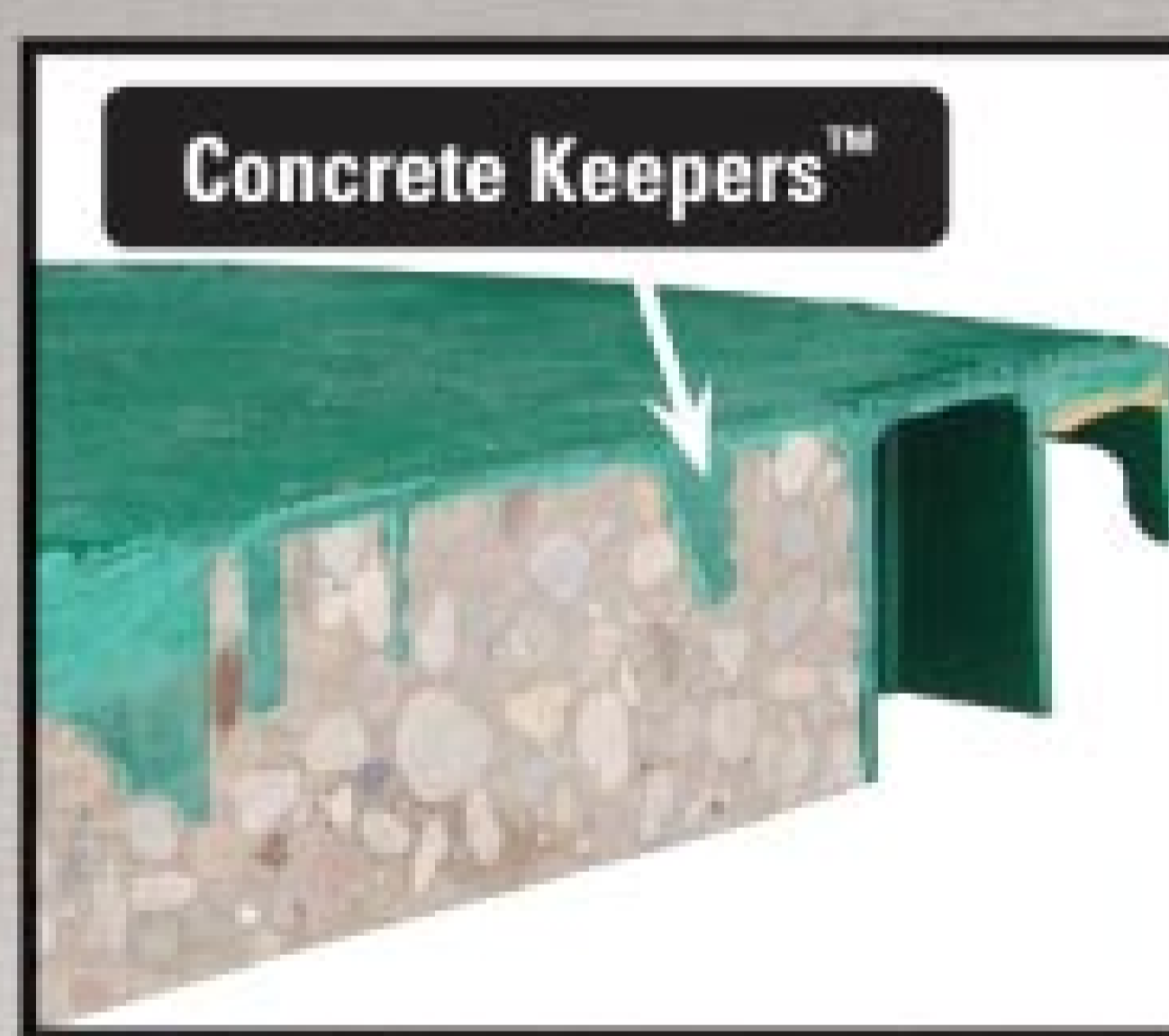

**Concrete Keepers™**

Holds up to 70 lbs of Concrete for Added Safety.

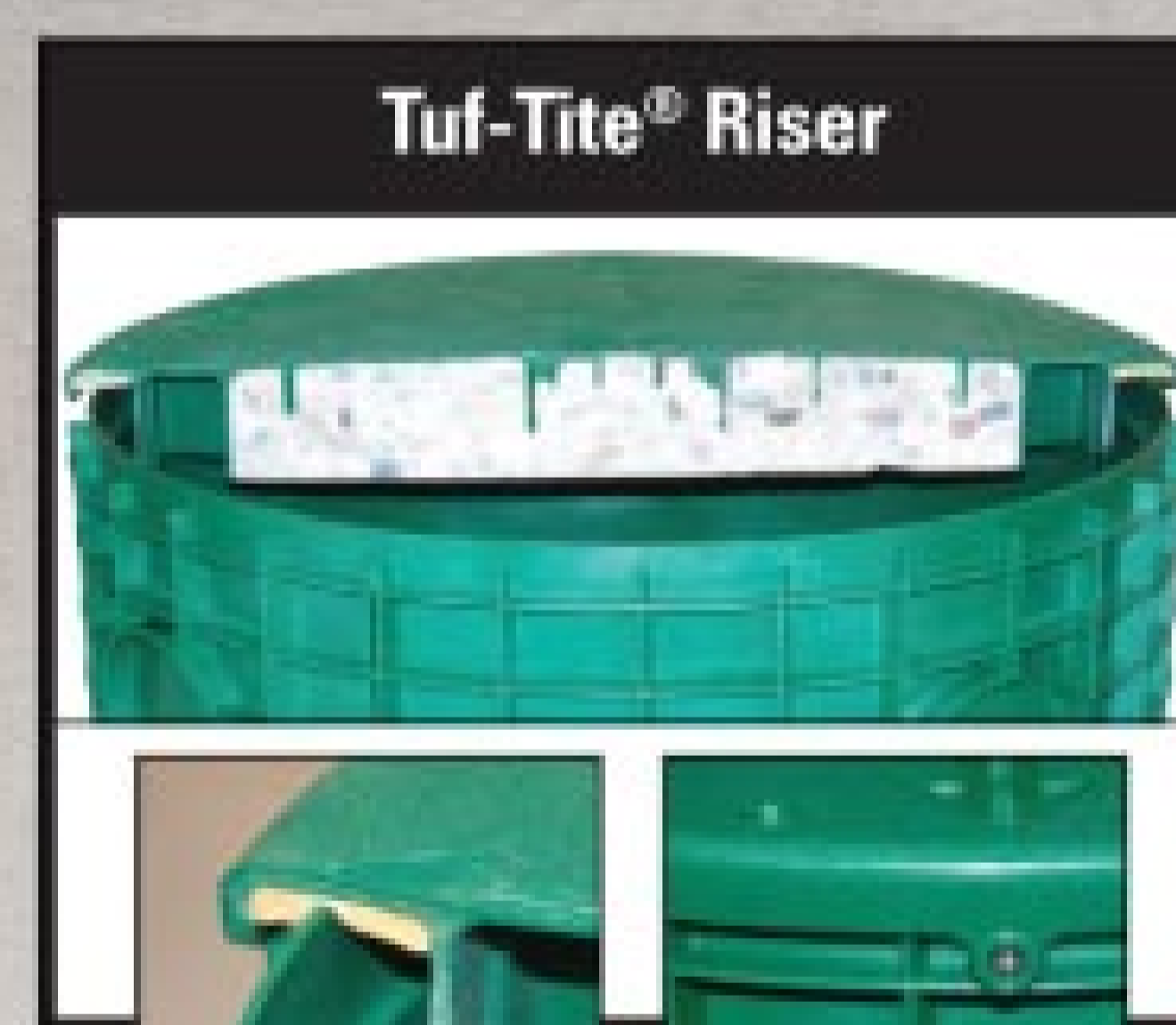

**Tuf-Tite® Riser**

Water-TITE Joint Vertical and Horizontal Safety Screws



**Corrugated HDPE Pipe**

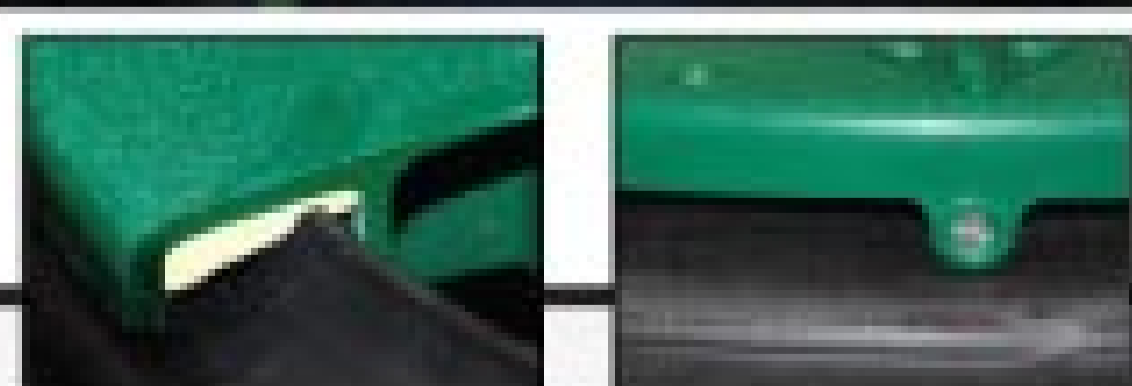

Water-TITE Joint Horizontal Safety Screws



**Corrugated PVC Pipe**

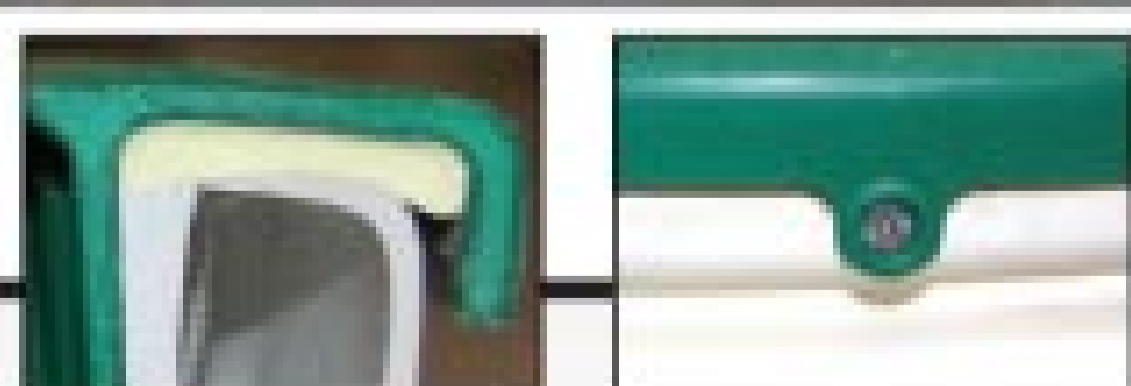

Water-TITE Joint Horizontal Safety Screws

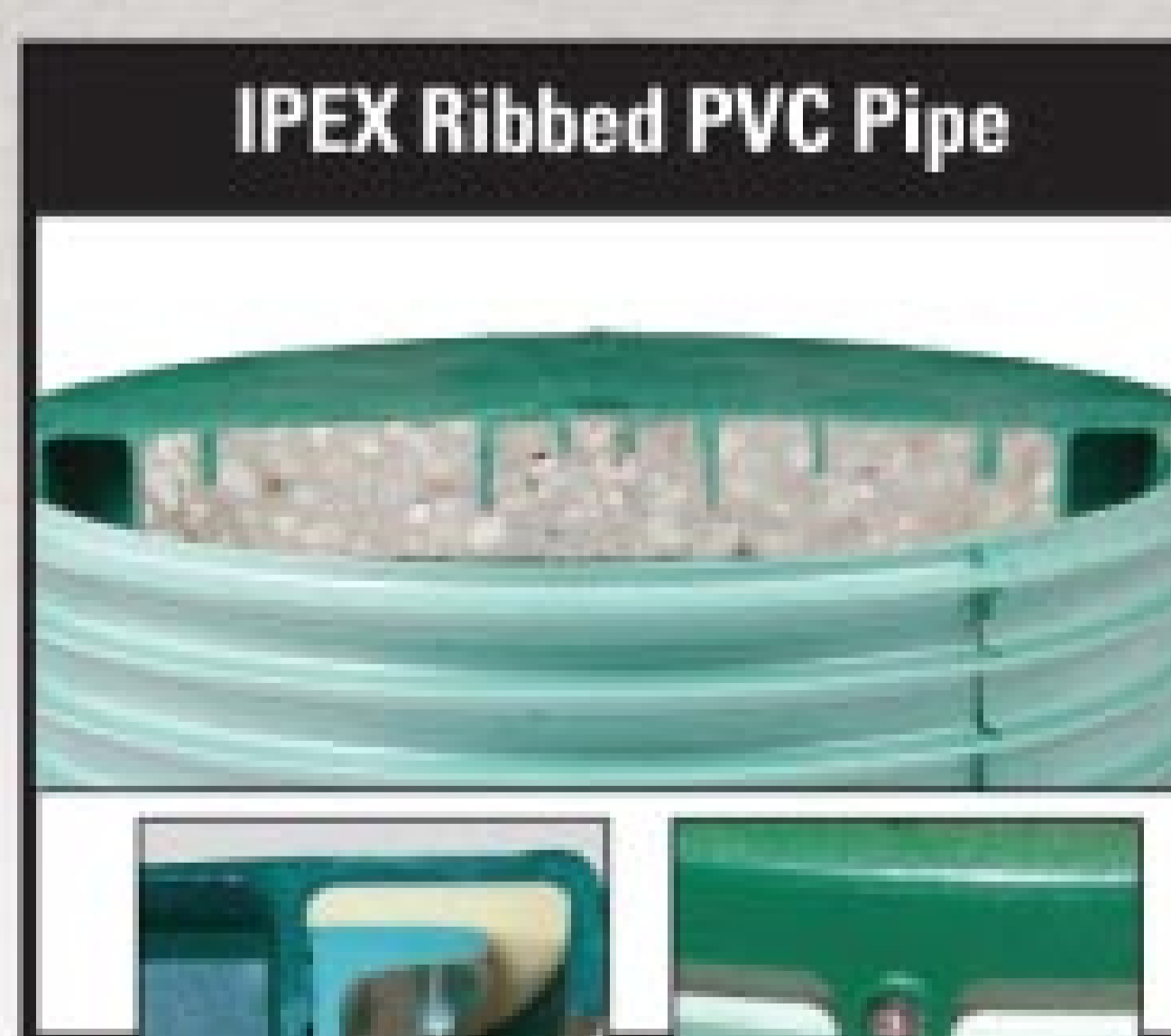

**IPEX Ribbed PVC Pipe**

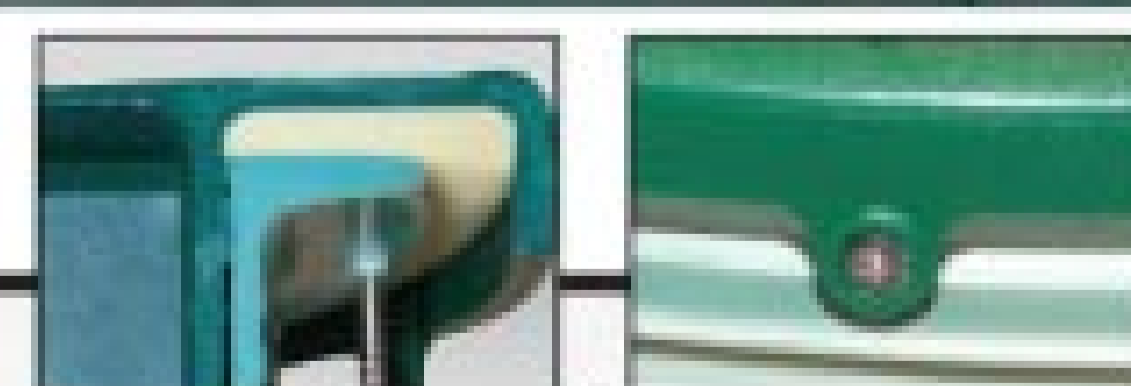

Water-TITE Joint Horizontal Safety Screws



**Plastic Riser**

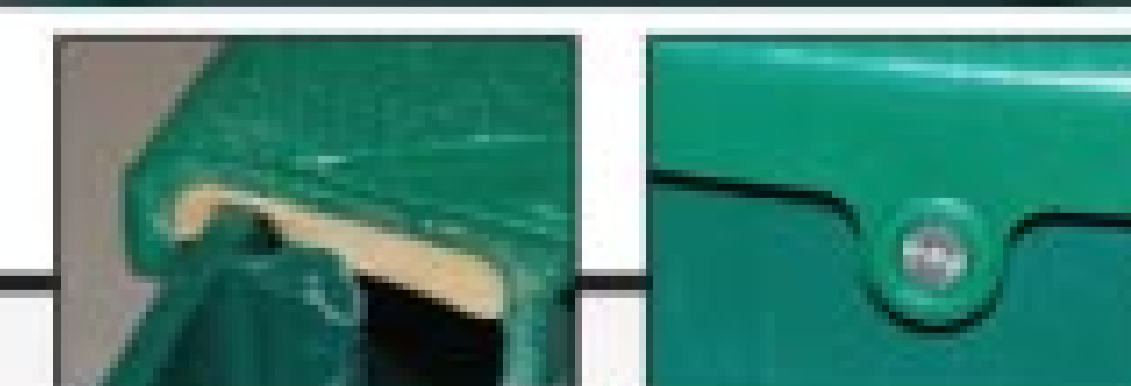

Water-TITE Joint Horizontal Safety Screws

Joe Stone agitates a septic tank using a Schmitz Brothers Crust Buster while James Stone readies the hose for pumping. (Photos by Rusty Nixon)



By *Scottie Dayton*

# The ROLLING STONES

**Busy Indiana father and sons team at Stone Excavating keeps moving forward to educate customers and keep pace with industry advances**

Customer education begins in the homeowners' back yard, asserts Jay Stone of Stone Excavating in Plymouth, Ind. And that special concern for keeping customers in-the-know about how their onsite systems work builds a reputation of integrity for this small, family-owned company.

In 2006, a desire to install onsite systems that lasted the lifetime of the components motivated Stone, 58, to learn about advanced treatment technologies. He became a pacesetter in Marshall County at a time when pump and haul and using less water were the only

solutions to system failures.

In response to customers requesting pump-outs and system maintenance, son James, 31, developed the company's pumping division. Today, he hauls 500,000 gallons of septage per year and, along with his father, conducts onsite inspections for real estate transfers. Son Joe, 26, heads up drain cleaning, while brother Josh, 21, helps evenings and weekends. Jay's wife, Charlotte, helps in the office. The only non-family employee, Lee Ulmer, handles the portable restroom service.

To increase efficiency and meet residential

pumping demand, the company ordered a 2010 International with 3,600-gallon stainless steel tank (200 gallons fresh) and a 400-cfm Masport pump from Best Enterprises Inc. The graphic-wrapped vehicle, on display at this year's Pumper & Cleaner Environmental Expo International, drew accolades from attendees. The flashy vehicle now attracts potential customers wherever it goes.

## GETTING STARTED

Growing up in his father's excavating business was all the help Jay Stone needed to start his own company in 1977. "Dad had stopped installing onsite systems, but customers still asked him to do it," Stone says. "I saw an opportunity to fill the void and opened J & J Excavating when I was 25."



## Profile

### Stone Excavating, Plymouth, Ind.

Owner: **Jay Stone**

Founded: **1977**

Employees: **4**

Service area: **20-mile radius of Plymouth**

Services: **Onsite installation, repair, location, and inspection, excavation, pumping, drain cleaning, and portable sanitation**

Associations: **Indiana Onsite Wastewater Professional Association, National Association of Wastewater Transporters Inc., North Central Indiana Association of Realtors**

Web site: **www.stoneexcavating.com**



Plymouth. The company, which manufactures plastic septic tanks, had just purchased Hydro-Action Industries aerobic treatment systems with aeration and clarification compartments. Stone also visited Aero-Tech, another Plymouth-based company manufacturing aerobic treatment units (ATUs) that use the extended aeration-activated sludge process. He became certified to install both products.

Today, repairs of failed systems are so numerous that the state Department of Health has told county health departments to use their best judgment. "The local regulators are well informed and interested in new technologies because of our lakes," Stone says. "Home sites are at a premium, but all lots have limited space. If contractors can install working systems, it's a real plus. Regulators recognize that."

Stone has always included the Department of Health in solving installation issues. He challenges officials to come up with

ideas before presenting his. If they disagree with his solutions, he asks for theirs. "When they find themselves at a loss, they become more receptive to our suggestions," he says.

Stone Excavating installs about 30 onsite systems per year, but most are repairs. "They often fail because contractors use installations as learning experiences," Stone says. "They don't compact the soil sufficiently, causing laterals to settle and thin-walled pipes to crack. We prevent that by backfilling with No. 8 stone. We also install effluent filters, although the code doesn't require them."

#### WE CAN DO THIS

System repairs included pumping tanks to evaluate their condition. "Whenever we hired a pumper, we ended up helping him do the work," James Stone says. "I felt silly having other people pump and do maintenance when we knew how. Furthermore, our customers were asking for those services. I urged Dad to get into these fields, and he put the

**"IF YOU TAKE CARE OF PEOPLE AND DO A GOOD JOB, THEY WILL USE YOUR SERVICES. OUR STRONGEST ADVERTISEMENT IS HAPPY CUSTOMERS TELLING FRIENDS ABOUT US OVER CLAM DIP AND CHIPS."**

Jay Stone

Below, James Stone pumps and sprays down a grease trap while providing service to a restaurant. At right, Joe Stone replaces a man-hole cover while James pumps.



Inspecting baffles, homogenizing solids and checking the entire system is why the company charges more than the competition for pump-outs. Since most are done through the riser, Stone uses a cheap underwater, battery-operated fish-finder camera with monitor to inspect the baffles and structural integrity of the tank. "Dad bought it on eBay because our MyTana drain-cleaning camera is too bulky to haul around on the truck," Stone says.

With no regulations requiring routine tank pumping, the company includes maintenance sheets with the dos and don'ts of septic systems in invoices and receipts. Most customers, on the computer's running calendar, receive one-, two- and three-year pumping reminders. "We call first to verify that they still want us to service the tank," Stone says. "Often, we find new owners in the home and they have no record of when the

tank was pumped last."

The company does little marketing. "If you take care of people and do a good job, they will use your services," Stone says. "Our strongest advertisement is happy customers telling friends about us over clam dip and chips."

#### NO STONE UNTURNED

Stone often noticed that the first professional on the homeowner's property wound up doing the repairs. "You can't troubleshoot problems without pumping the tank," he says.

responsibility on my shoulders."

In 2003, the family bought a 1997 International with 2,600-gallon tank, Masport pump, and jetter from Quality Tank Trucks and Equipment. "Marshall County has 47,000 people, many with onsite systems, but the population is sparse enough that it doesn't overwhelm us," Stone says. "Plymouth is in the middle of the county, which is almost square, so our 20-mile service radius takes us to the farthest corners in about 20 minutes." Residential and commercial customers, mostly restaurants, are split 70/30.

Like his father and grandfather before him, James Stone spends as much time as possible educating homeowners during pump-outs. "We're seeing a lot of people moving from town to little subdivisions," he says. "They've never owned an onsite system and are curious. Educating them that ignoring maintenance causes future larger-dollar problems is good for my business and for my competitors."



James Stone attaches a vacuum hose in preparation for cleaning out a restaurant grease trap.

## Following in Dad's footsteps

Jay Stone, 58, of Stone Excavating in Plymouth, Ind., loves his work and does not intend to leave, but he nevertheless groomed his sons well. James, 31, Joe, 26, and Josh, 21, started at the bottom of the business and helped build it. "We have a vested interest," James says. "If Dad and Mom go away for a week, I have to handle things. If I mess up, it could harm the business."

Jay and his father served as role models to the boys. "They worked hard for everything, and raised us with the same work ethic and to do our best," James says. "That kind of training makes a big difference in how we do business. It's not just about doing the job correctly and making a profit. It's about caring for people. If you're too busy to help them, then you've grown too big."

How much to expand is a difficult decision, especially when employees seldom take ownership in a business. "I'm looking for a little more work and to expand, but there has to be a happy medium," James says. "We always take time to re-evaluate our growth pattern, making sure that what we're doing is right and better, not just bigger."

"The pump truck enabled us to compete. Even finding minor problems during a routine pump-out is an advantage for customers."

Before Stone even realized the business was out there, people began requesting real estate transfer inspections. "Getting our foot in the door wasn't hard once we had the truck and I became certified," he says. Stone averaged 20 inspections per year until the real estate bubble burst. To gain back and expand that business, he joined the North Central Indiana Association of Realtors. "Being associates, brokers are more apt to call us," he says. James became a certified inspector in March.

Another business opportunity resulted when the company had requests for portable restrooms at jobsites. "We bought 10 PJN3

units from PolyJohn Enterprises Corp. and it snowballed from there," Stone says. This led to the purchase of a 300-gallon skid-mounted vacuum unit from Best Enterprises Inc. carried on a 1999 Mitsubishi cab-forward truck.

Then homeowners began asking for units at weekend events. Stone bought 20 PolyJohn Fleet models with hand sanitizers. He also won the contract to provide portable sanitation for the Plymouth Latino and Yellow River Festivals. To improve efficiency, the family built a 3,000-square-foot pole barn with three truck bays and an office in 2008. The shop made it easier to maintain the vehicles, and moving the office out of the home helped separate Stone's personal and work life. Then another boost in efficiency appeared on the horizon.

By 2009, James Stone was pumping 500,000 gallons of septage per year and running the wheels off his truck. It was time to upsize. The family ordered the 2010 International from Best Enterprises, and Stone worked with Josh Wakeland of IE Signs and Graphics in Plymouth to design the vehicle wrap.

"We wanted a unique design that caught

people's attention," Stone says. "We also wanted our name in the same font that was on the first truck, and to color match the lettering with the blue on the new truck." Wakeland followed the company's red, white and blue or silver color scheme by modifying an American flag for the background, then overlaid the letters. The wrap was printed on clear self-adhesive vinyl 16 feet long by 6 feet high.

### HONOR BOUND

"The truck enables me to make multiple stops before dumping," Stone says. "I can pump seven tanks, eat lunch, and return to the shop by 2:30 p.m. That would have taken all day with the old truck, but now I could even pump another two or three tanks before coming in."

The third generation of Stone Excavating is steeped in its foundation of integrity and good service. "My father did an excellent job teaching us that your word is your bond," Stone says. "Even if you have to take a loss on something, it's better than tarnishing your honor. That philosophy has been very important to the success of our business and will remain so." ■

### MORE INFO:

**Aero-Tech**  
574/935-0908  
[www.aerotech-atu.com](http://www.aerotech-atu.com)

**AK Industries  
Hydro-Action  
Manufacturing**  
800/370-3749  
[www.hydro-action.com](http://www.hydro-action.com)

**Best Enterprises Inc.**  
800/288-2378  
[www.bestenterprises.net](http://www.bestenterprises.net)

**Crust Busters/  
Schmitz Brothers**  
763/878-2296  
[www.crustbusters.com](http://www.crustbusters.com)

**Masport Inc.**  
800/228-4510  
[www.masportpump.com](http://www.masportpump.com)

**MyTana Manufacturing  
Co. Inc.**  
800/328-8170  
[www.mytana.com](http://www.mytana.com)

**PolyJohn Enterprises  
Corp.**  
800/292-1305  
[www.polyjohn.com](http://www.polyjohn.com)



The Stone family is proud of its new service rig — covered in a patriotic graphic wrap — a 2010 International with a 3,600-gallon stainless steel tank from Best Enterprises.

PORTABLE TOILET  
SERVICE UNITS  
SLIDE IN UNITS  
HOISTED UNITS  
ROLL OFF UNITS  
CUSTOM UNITS

www.pikrite.com

**pikrite**

Manufacturing & Sales - 60 Pik Rite Lane - Lewisburg, PA 17837

**1-800-326-9763**



Thank you to  
*Fought's Disposal*



NOW AVAILABLE  
IN ALUMINUM,  
Built by Pik Rite



DEODORIZING · ODOR CONTROL · CLEANING SOLUTIONS

**chempace**  
corporation

800.423.5350

www.Chempace.com

PORTION CONTROL  
HOLDING TANK TREATMENT

**NEW!**



NON-STAINING  
BLUE DYE

FORMALDEHYDE  
FREE

DISSOLVES QUICKLY

BIODEGRADABLE

EFFECTIVE  
ODOR CONTROL IN  
EXTREME CONDITIONS



CALL TODAY  
FOR YOUR FREE  
SAMPLES!

Want to "OWN" your  
pumper accounts?

Combine Hot Drain Line Jetting with your Pumper Service!

**Xtreme Flow Hot Jetter**

Model #HJ2TA8536

Tandem Axle Trailer

35 HP Vanguard

8.5 GPM @ 3,600 PSI



On Sale **\$19,995** List Price \$24,995

Call For  
Details **800.624.8186**

Over 25 years  
of building  
quality equipment  
**HotJetusa**  
DRAIN LINE JETTING EQUIPMENT®

Premium Jetting Equipment

Factory Direct Pricing

www.hotjetusa.com



# TOP LINE

## AQUASTAND



Fits inside most assembled portable toilets for easy transport.

The **AQUASTAND** is Armal's premiere outdoor portable hand-wash station.



Armal Inc. 122 Hudson Industrial Drive, Griffin, GA 30224 - USA  
Phone 770 491 6410 - Fax 770 491 9458 - Toll Free 866 873 7796  
armal-inc@armal.biz

# Armal

[www.armal.biz](http://www.armal.biz)

# Rely on Reelcraft



Cast aluminum hose reels Series 8000

Photo courtesy of Vactor, a subsidiary of Federal Signal Corporation

**New!**

Compact, heavy duty dual pedestal hose reels

Series DP5000/DP7000

Made in USA



## Built better to perform better

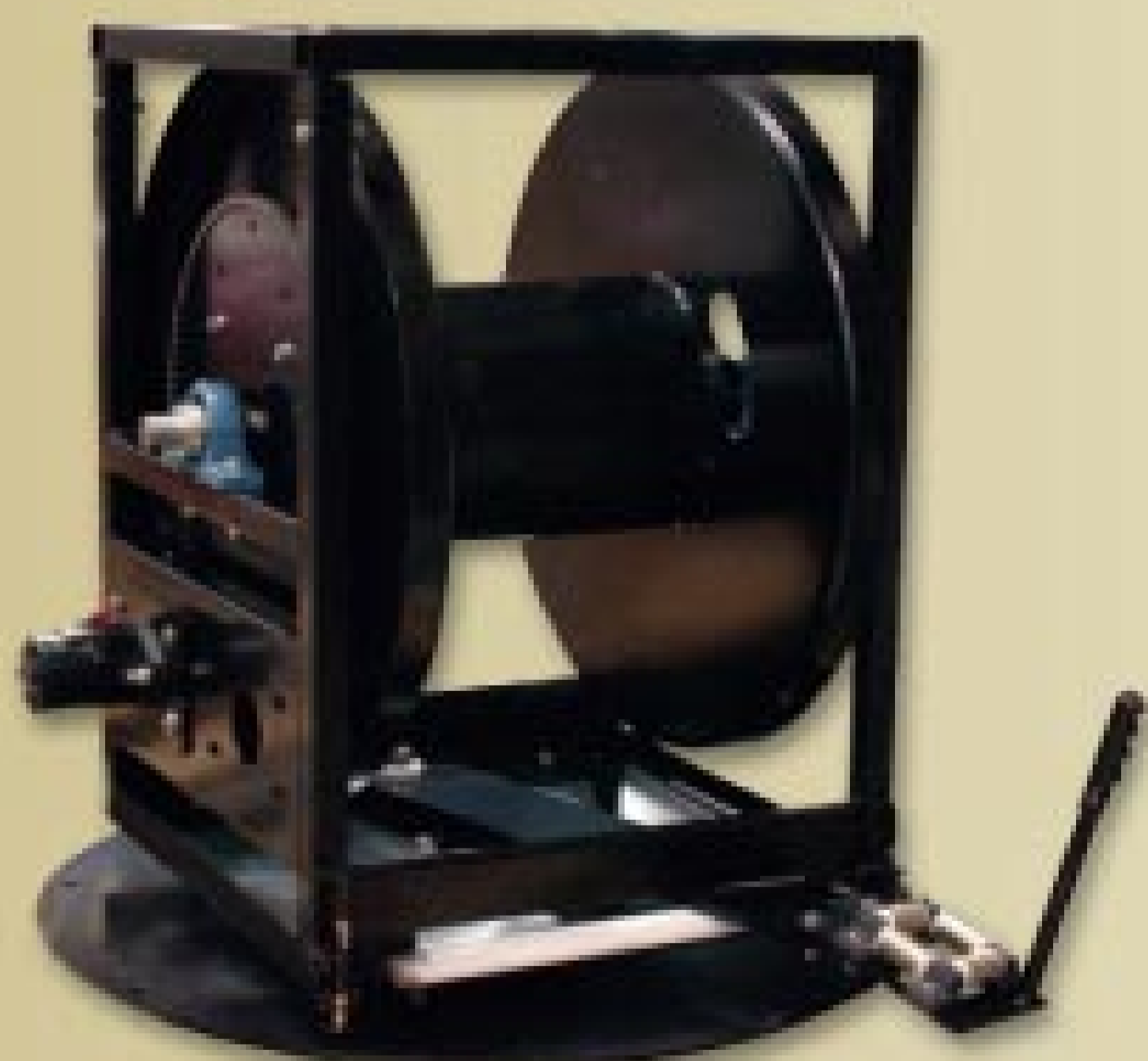

**New!**

Jetter hose reels built to your specs

Nordic Series 2415

Made in USA

**REELCRAFT**

www.reelcraft.com | 800-444-3134

## Milwaukee Rubber Products

### KANAFLEX HOSE

#### Rubber Hose 300 EPDM

All Weather Water Suction Hose



1-1/2", 2", 2-1/2", 3", 4", 6" Cut to Length

#### 220 RS

Low Temp Rubber Water Hose



1-1/2", 2", 3", 4", 6" Cut to Length

#### 180 AR

Abrasion Resistant Suction Hose



1-1/4", 1-1/2", 2", 2-1/2", 3", 3-1/2", 4", 6", 8" Cut to Length

#### 180 HR

High Temp Suction



4", 6", 8" Cut to Length

#### KANALINE SR

Suction & Discharge Hose



1-1/2", 2", 3", 4", 6", 8", 10" Cut to Length

#### Plastiflex Black/ Yellow Hi-Vac Suction Hose (Tigertail)



1-1/2", 2", 3" Lengths: 20, 25, 30, 35, 40, 50, and 60 FT. W/Cuffs.

#### Sewer Hose Guides

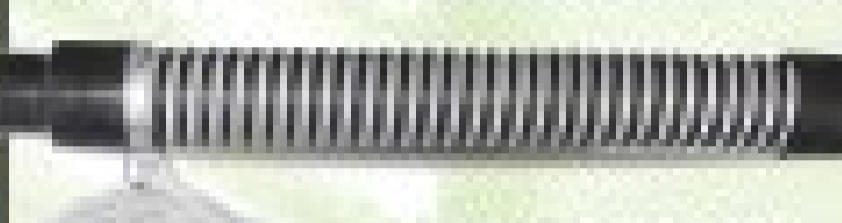

2" ID X 3'  
3" ID X 3'  
W/Cuffs, Clamp, Rope & Ring

#### Green Monster Vac Hose



2", 3", 4", 5", 6", 8" 50 ft Boom Hose, Cut Lengths available

#### Piranha Hose

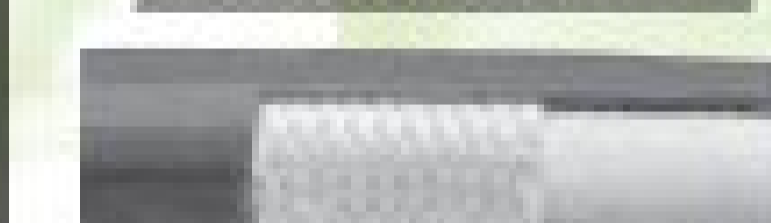

Sewer Jetting Hose

#### Hose For All Applications

Chemical Hose, Water, Air, Septic, Oil Hose, Compressor Hose, Grout Hose, Sandblast, Hot Air, Hot Tar, Asphalt Hose, Push-On, Vac Hose.

Call For Your Application.

### VALVES

#### Brass Lever Action Gate Valves



2", 3", 4", 6"

#### Piston Valves



Brass 4", 6", 8" Flanged Brass 4", 6", 8" Flanged X Threaded Brass 4", 6", 8"

#### Double Acting Pneumatic Actuator



4", 6" and 8" brass piston gate valves

#### Betts Sliding Gate Valve



3", 4", 6" sizes Flange X Flange, and Flange X Thread

#### Non-Bolted Ball Valves



2", 3", 4" sizes

#### Poly Pro Ball Valve



Compact Pro 2" Full Port 1-1/2", 2", 3", 4" 90° With Handle 2"

### PUMPS



Jurop

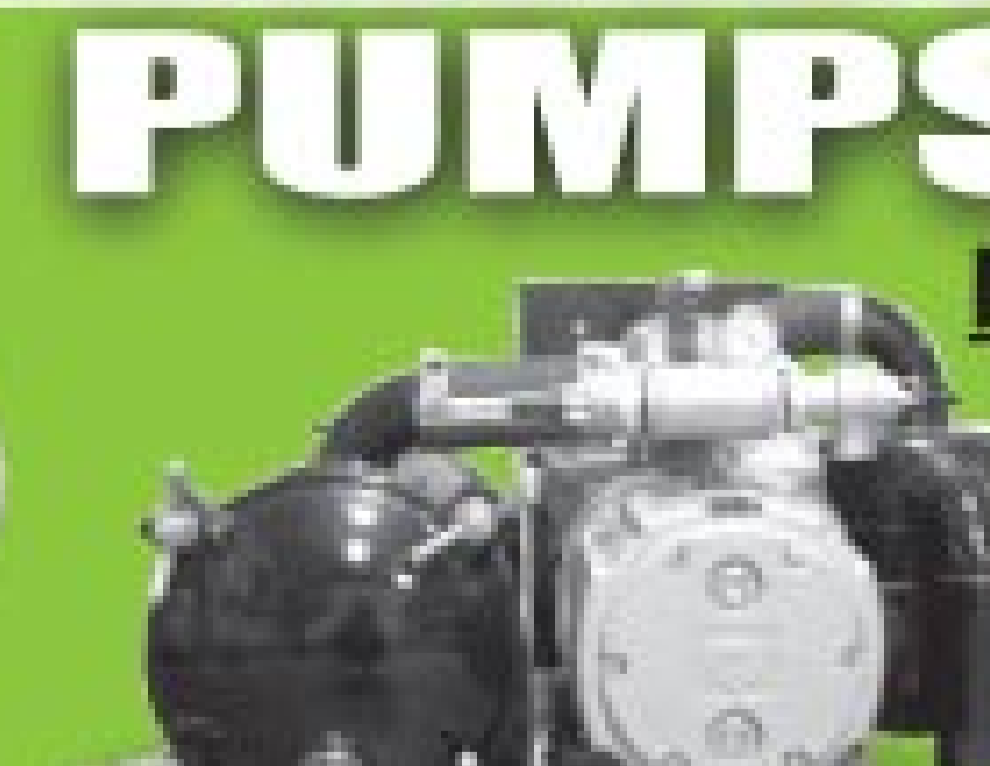

Moro



Call For Prices Toll-Free  
**1.800.325.3730**  
www.milwaukeeerubber.com

Milwaukee Rubber Products, Inc.  
P.O. Box 451 • Butler, WI 53007  
N52 W13319 Falls Creek Ct.  
Menomonee Falls, WI 53051

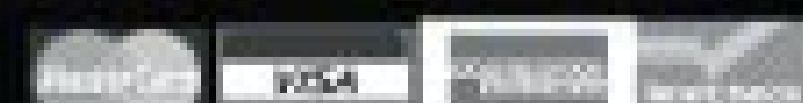

**BEST ENTERPRISES, INC.**  
*Manufacturer of Stainless Steel Tanks*



Best Enterprises, Inc.

Cabot, AR 72023

1-800-288-2378

[www.BestEnterprises.net](http://www.BestEnterprises.net)

# Longhorn Tank Company

Truck  
Mounted  
Tanks  
for Septic,  
Portable Toilets,  
Grease Traps, Etc.



Aluminum,  
Stainless,  
and  
Steel  
Vacuum Trailers  
in any Size

Call or Email Us For a Quote Today

800-422-9840

sales@longhorntank.com

PO Box 1147 Gravette, AR 72736

Fax 479-787-6935

**Wee Engineer**  
WITH IMAGINATION

Call us for a quote

**Best Heavy-Duty Portable Toilet Trailers on the Market**



24ft....\$8,400  
28ft....\$8,700  
34ft....\$9,678

Our customers are pleased with the time they save loading and unloading toilets from our uniquely designed tie-down system.

**1999 International 8100,**



Cummins M-11, 280 HP, 190,000 miles, 9-speed. 2004 Wee Engineer carbon steel tank, 2500-gallon, Moro AC-4 Pump, 36" rear manway.

**- NICE TRUCK -**

Price: .....\$33,500

**WE**



**HEATED COLLARS**

Preventing your valves from freezing will help your profits during the winter months.

1.5-2" .....\$110  
3" .....\$165  
4" .....\$198  
6" .....\$297

Installation kit and 110 volt heater kit available

**WEE VAC** The Wee Vac fits through a standard doorway and can pump up to 40 gallons of grease at a time. It has a female camlock so it can be downloaded into your truck. It features a 110 volt vacuum pump.  
Price: \$1,240



**SPRING MOUNTS**

decrease fatigue on your tank frame, mounts to most tanks, easy bolt or weld-on style, heavy-duty stress relieved springs.

Mounts with springs..\$82.00  
Springs alone .....\$11.00 each



P.O. Box 39 Dayton, IN 47941 Toll-Free: **877-296-2555** Phone: 765-296-2027 Fax: 765-296-3027

[www.wee-engineer.com](http://www.wee-engineer.com)

# THE WARRIOR STANDS ALONE.



**SPARTAN**  
FOR TOUGH CUSTOMERS.  
SINCE 1943

From the most trusted name in the business comes the industry's sleekest, quietest trailer jet ever. Spartan's new, fully enclosed, 4,000 PSI Warrior features exclusive soundproofing technology for engine noise below OSHA's strict standard for mandatory hearing protection. And when it comes to packing in all the power and performance you need to conquer your toughest jobs, there is no competition.



**Pop the hood:** Uncover all the hard-hitting features and specs at [spartantool.com](http://spartantool.com).

CONTACT US TODAY | 800.435.3866

Jason Graves removes a Zabel filter for cleaning while David Miller handles the vacuum hose. (Photos by Christopher Malinger)

# A Youthful Outlook

**After 25 years in the industry, Wisconsin pumper David Miller figured he was moving toward retirement. Then an energetic assistant came along and ramped up his enthusiasm for the business.**

By Ken Wysocky

**J**ust when David Miller figured he'd ease up on his career gas pedal and coast into retirement, he finds himself more invigorated than ever about his business, Miller's Septic Service in Mauston, Wis.

The reason? Jason Graves, the boyfriend of his 22-year-old daughter, Kristin, is joining the company — and perhaps eventually will take over. While there's no guarantee the latter will happen, Miller nonetheless is happy about the unexpected chance to pass on the lessons he's learned after 25 years in the business and, at the same time, view the industry through the prism of Graves' more progressive ideas.

"It's an exciting time," Miller says. "You get into the rut of doing things the same way for 25 years. I'm winding down, but if Jason takes over the business, he's got to look down the road 25 years for himself (in terms of new technology).

"I'm fine with it," he says of Graves' ideas about how to modernize the business. "It's a little bit scary, but I'm doing more reading up on new technology. And I head to the Pumper show (Pumper & Cleaner Environmental

## Profile

### Miller's Septic Service Mauston, Wis.

Owners: **David and Peggy Miller**

Founded: **1985**

Employees: **2**

Services: **Septic tank pumping**

Services area: **About a 40-mile radius of Mauston**



**"JASON ALWAYS SAYS HE'S PUMPED, WHICH GETS ME EXCITED, TOO. IT GIVES YOU A BLAST OF ENERGY AGAIN WHEN SOMEONE'S INTERESTED IN WHAT YOU'RE DOING ... IDEALLY, HE'LL TAKE OVER THE BUSINESS. THIS BUSINESS HAS PROVIDED A WONDERFUL LIVING FOR MY FAMILY, AND IT JUST MIGHT DO THE SAME FOR HIM, TOO."**

David Miller



David Miller and Jason Graves at the company's shop with Miller's 2010 Kenworth built by Advance Pump & Equipment and pink 2001 International built by Wee Engineer.

Expo International) with a whole new outlook. It's like I'm starting a new business all over again."

Graves' presence also will allow Miller to spend more time with his wife, Peggy, and two other daughters, Courtney, 13, and Kailey, 11. That's more important than ever to Miller after 25 years of long hours and weekend service calls. Fiercely independent, he's been dead-set against hiring an employee, even though there's been enough work for two people for many years.

"I'm pretty stubborn," Miller admits. "But there comes a time when you've got to stop and smell the roses, too."

With an employee now on board, Miller Septic purchased a second truck: a low-

mileage, 2001 International 4900 with a 2,500-gallon steel tank, built by Wee Engineer Inc. in Dayton, Ind. Miller already owns a 2010 Kenworth T370 with a 3,000-gallon aluminum tank, built by Advance Pump & Equipment Inc. in Peosta, Iowa.

At the same time, Graves is gently prodding Miller to consider ways to modernize the company. "He looks at my stuff and says, 'I know you've done things this way for a long time, but have you ever thought of this or that?'"

Graves is considering several different technologies, including a truck-mounted waterjetter to open up additional revenue streams; a GPS to plan out the most efficient and economical route for service calls, saving

time and reducing mileage wear-and-tear on the trucks, and a computerized customer database and accounting system.

### A HUMBLE START

Computers and GPS systems were the last things on Miller's mind in 1985, when he started pumping septic tanks after holding several other jobs. Upon graduating from high school in 1978, Miller — the third of nine children — spent several years doing everything from erecting pole buildings to road construction work to a factory job.

"I hated working in a factory," he recalls. "I didn't like being stuck in a building all day. Plus I would finish my work by 11 a.m., then be told to stay standing and act busy. It wasn't



Miller with daughter (from left) Courtney, his wife, Peggy, daughters Kailey and Kristin and Graves.



Miller pumps a septic tank with the 2010 Kenworth.



for me. I've got a strong work ethic."

So he quit the factory job and started looking for a business to buy while working part time at a lumberyard. He found his calling in the want ads, where a local pumper was selling a used truck. Miller was flat broke, so his father co-signed a loan for \$5,400.

The truck was nothing special, a 1978 Chevrolet one-ton with a homemade, 750-gallon tank; a pipe-and-tennis-ball contraption that served as a shutoff valve; and no vacuum pump. "You generated vacuum off the intake manifold on the engine," he says. "It gave me maybe 13 or 14 inches of vacuum."

For added financial security, Miller kept

his part-time job as he slowly established his new business. During those early years, he also drove a school bus and cleaned a local retail store parking lot with a sweeping machine. At one point, a typical day meant getting up at 3:30 a.m. to sweep the parking lot, driving school bus from 6 to 8 a.m.; make service calls; then driving bus again at 3 p.m.

"It was a pretty hectic schedule for a few years," he says. "But my dad was the best role model I could ever have. He worked his tail off, running a general store for 30 years and raising nine kids. I remember watching Mom cry a few times, wondering if they were going to make it. But today, Miller's General Store is

the oldest family-owned general store located in the same building in the entire state of Wisconsin (it's now run by one of Miller's brothers, Mark)."

#### BUSINESS KEPT GROWING

Miller employed a no-frills marketing campaign to slowly grow his business. He printed business cards, then solicited customers by going door-to-door on weekends or whenever he had free time. Having grown up in the area, he already knew a lot of people, which made it somewhat easier.

The young entrepreneur also posted signs promoting his business on bulletin boards at local campgrounds, lumberyards, grocery stores and the like. "I basically hung them wherever someone would let me put one," he says. "At first, it was slow going. I did my first three jobs for free for family members.

"But after that, I got two jobs a week," he continues. "Then three or four jobs a week. At that time, it just provided extra cash. The \$45 I got for pumping a tank was more than I made in a day at the lumberyard."

After four or five years, the business became a full-time endeavor. Miller says the key to growth was providing top-notch service — and never saying no when the phone rang.

"All these years, I never told people no," he says. "If I answer the phone, I'll be there. Word-of-mouth referrals also helped the business take off."

Miller also benefitted from a sudden growth explosion in homes around nearby Castle Rock Lake. "Builders knew who I was and referred me. Plus, there were three home-

**"ALL THESE YEARS, I NEVER TOLD PEOPLE NO. IF I ANSWER THE PHONE, I'LL BE THERE. WORD-OF-MOUTH REFERRALS ALSO HELPED THE BUSINESS TAKE OFF."**

**David Miller**



Miller and Graves use a Spartan 758 jetter to clear a lateral line in a mound septic system.



## What about the skunk?

Making light of something offensive — like human waste — can make it more palatable. For proof, consider the 2010 Kenworth T370 vacuum truck owned by Miller's Septic Services in Mauston, Wis. It's decorated with flowers and two skunks, inspired by the Warner Bros. cartoon character Pepe Le Pew and Flower from the Disney movie classic, *Bambi*, says owner David Miller.

Moreover, the company's second truck — recently purchased to accommodate a new employee, Jason Graves — is painted pink and adorned with the skunks and flowers.

Which raises a question: At what point do jokes about odor and pumping human waste cross the line from effective marketing into low-brow bathroom humor that demeans the industry and sets back efforts to improve professionalism?

For Miller's wife, Peggy, the answer is as plain as the flowers and skunks on the company's trucks — and also what isn't on them. In her mind, visibility makes for good branding and name recognition/retention. But she firmly rejects the concept of slogans that make jokes about human waste.

"Those kind of slogans give the industry a bad name," she says. "We've never done anything with slogans because we want to keep it classy."

Adds David Miller: "I don't like the negative connotation (of the industry), but when's the last time you saw someone smile when a septic truck pulled up? It comes down to what you want to portray to your customers. I really think the skunks and flowers portray a positive image."

The eye-catching design also enhances brand recognition, which comes in handy when customers lose one of Miller's business cards or forget the name of the company that last pumped their tank a couple years ago.

"Over the years, I've had at least a dozen customers take pictures of my truck (the company's previous truck also carried the flowers and skunks design)," Miller says. "From what I've seen, I believe it helps customers remember you. If they forget our name, they sometimes call and ask if we're the guys with the skunks and flowers on the truck. They may not remember the name, but they remember the truck."

"If someone could convince me it's a bad thing, I'd take them off right away," he says.

As for the pink truck, the jury is still out. Peggy Miller loves it, and says she got the idea from a story about another pink truck she read in *Pumper*. Dave Miller, on the other hand, thinks it's OK, but "a little feminine," as he puts it. "When we told Jason, he first thought we were kidding," Miller says. "But he's on board with it now. Besides, the skunks and flowers cover a lot of the tank."

"Will the pink color work? Ask me in a year," he chuckles.

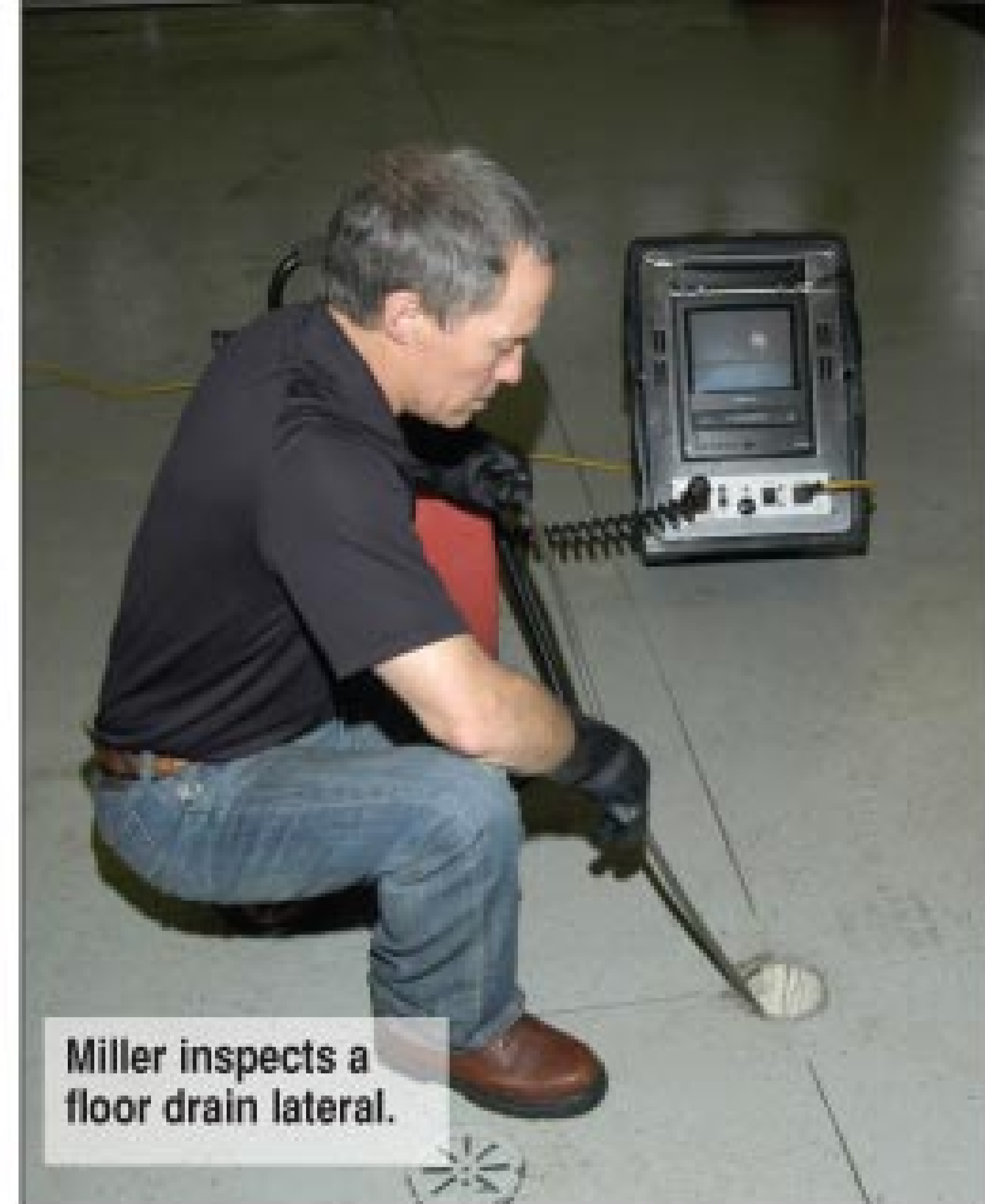

Miller inspects a floor drain lateral.

owner associations around the lake with about 50 to 100 homes each."

### STAYS OUT OF DEBT

Another key to Miller's success was a conservative financial philosophy, ingrained by his parents.

"My motto is this: If I can't pay for it, I don't need it," he explains. "I hate being in debt. Then I'm working for the bank, not myself."

After owning a couple used trucks, Miller bought a new one shortly after he went into pumping full time: a 1988 Ford with a 2,500-gallon tank. The much-bigger capacity put him "into the big world," as he puts it. It was also his first truck with a vacuum pump.

Miller's strategy with vehicles is to employ careful maintenance and sell them after five or six years. That way they retain solid resale value, plus it reduces the odds of unexpected and profit-robbing downtime caused by breakdowns. He says he's never had a problem selling his trucks. "Most times they're sold before the new one even comes in," he says.

The company's cash-flow situation has been enhanced over the years by a lucky break: His brother Carl is a farmer who lets Miller land-apply septage on his land. Considering that the nearest treatment facility is 20 miles away and charges around \$35 per 1,000 gallons, plus a \$10 fee to pass through the gate, land application has been a financial boon, Miller notes.

"All my competitors land-apply, too, so I couldn't be competitive if I had to go to the treatment plant," he says. "It's \$115 for a truckload, plus the travel time and the fact that the facility isn't open on nights and weekends."

But increasingly tighter land-application regulations make Miller uncertain about its



long-term viability. "I could get a letter tomorrow telling me I can't do it anymore," he says. Moreover, crops grow on much of the land during summer, making it unavailable during the peak business season.

### ANOTHER NEW START

Disposal concerns aside, Miller finds himself with a newfound spring in his step with Graves on board.

"Jason always says he's pumped, which gets me excited, too," Miller says. "It gives you a blast of energy again when someone's interested in what you're doing. Right now, my goal is to take some time off, yet still be involved in the business."

"As for down the road, who knows?" he

adds. "I don't want to put any pressure on him. Ideally, he'll take over the business. He really wants to run his own business. This business has provided a wonderful living for my family, and it just might do the same for him, too."

With a can-do work ethic like Miller's, anything is possible. ■

### MORE INFO:

**Advance Pump & Equipment Inc.**  
877/557-PUMP or 7867  
www.advancepump.com

**Spartan Tool LLC**  
800/435-3866  
www.spartantool.com

**Wee Engineer Inc.**  
765/296-2027  
www.wee-engineer.com



**MARCH 2-5, 2011**

**LOUISVILLE, KY**  
KENTUCKY EXPOSITION CENTER

# POWER YOUR *Future*

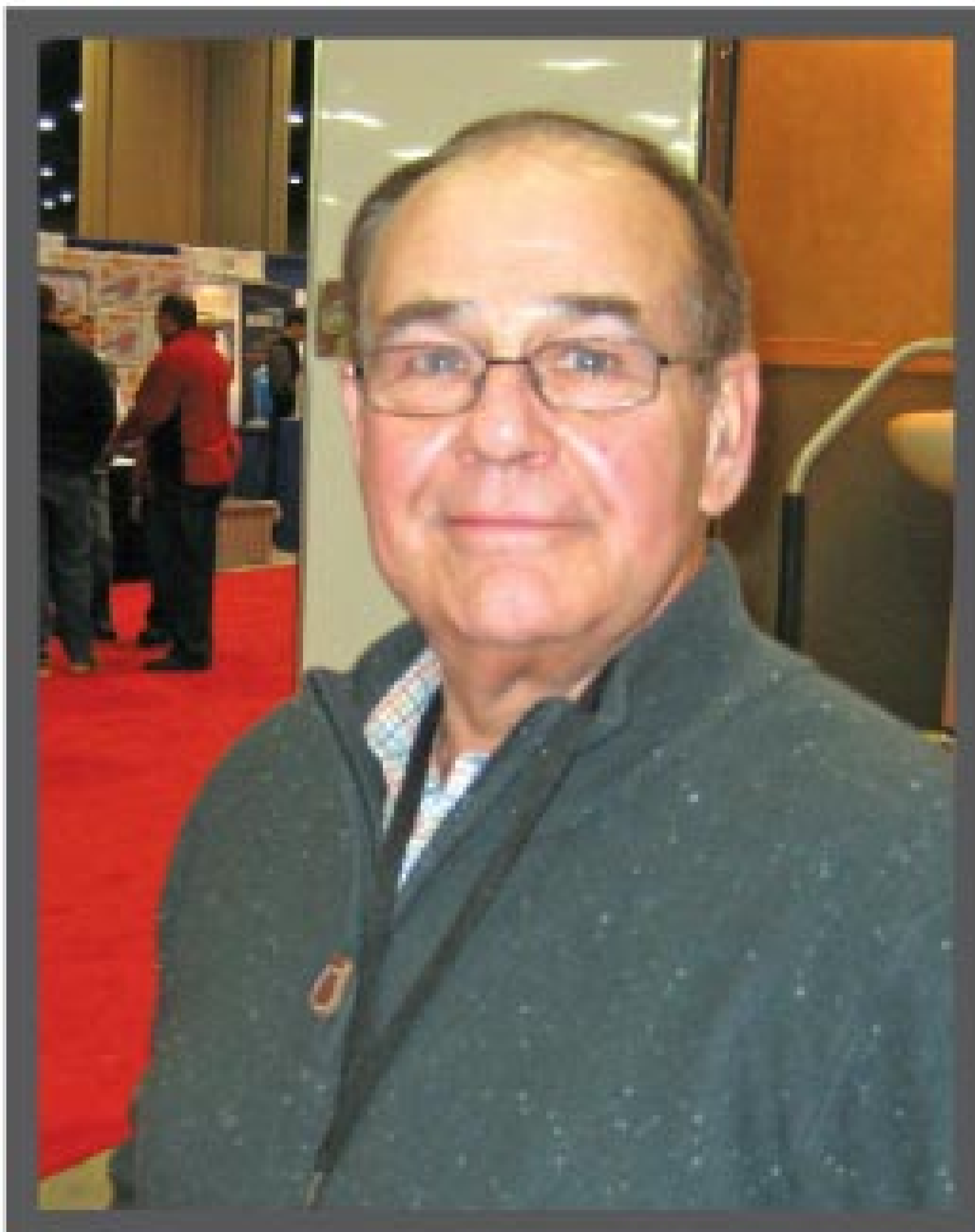

**JACK BAILEY**

Wind River Environmental  
Hudson, Mass.

**Jack Bailey** loves networking with other business owners at the Expo. "It's an opportunity to see everything you need to see and meet everyone you need to meet," he says. "We've seen new technologies that might improve our business. It's good to come here and deal directly with vendors. It's the best way to get two or three different quotes. The Expo helps us create business deals, buy new equipment, and get the best prices."

***POWER your Future***  
**COME TO THE 2011 EXPO.**



## WHO SHOULD ATTEND? IF YOU ARE IN...

- SEPTIC PUMPING
- ONSITE INSTALLATION
- PORTABLE SANITATION
- DEWATERING
- GREASE HANDLING
- SEWER CLEANING
- LATERALS & MAINLINES
- TV INSPECTION
- PIPELINE REHAB/CIPP
- WATERBLASTING
- HIGH-PRESSURE CLEANING
- SAFETY EQUIPMENT
- CONFINED SPACE
- LIFT STATION MAINT.
- COMPUTER SOFTWARE
- INDUSTRIAL VACUUMING
- HYDROEXCAVATION
- UNDERGROUND TRENCHLESS PIPE REPAIR
- UTILITY LOCATION

**...YOU NEED TO BE HERE!**



**ADDITIONAL  
INFORMATION AT:**

**WWW.PUMPERSHOW.COM**

# REGISTER TODAY AND SAVE!

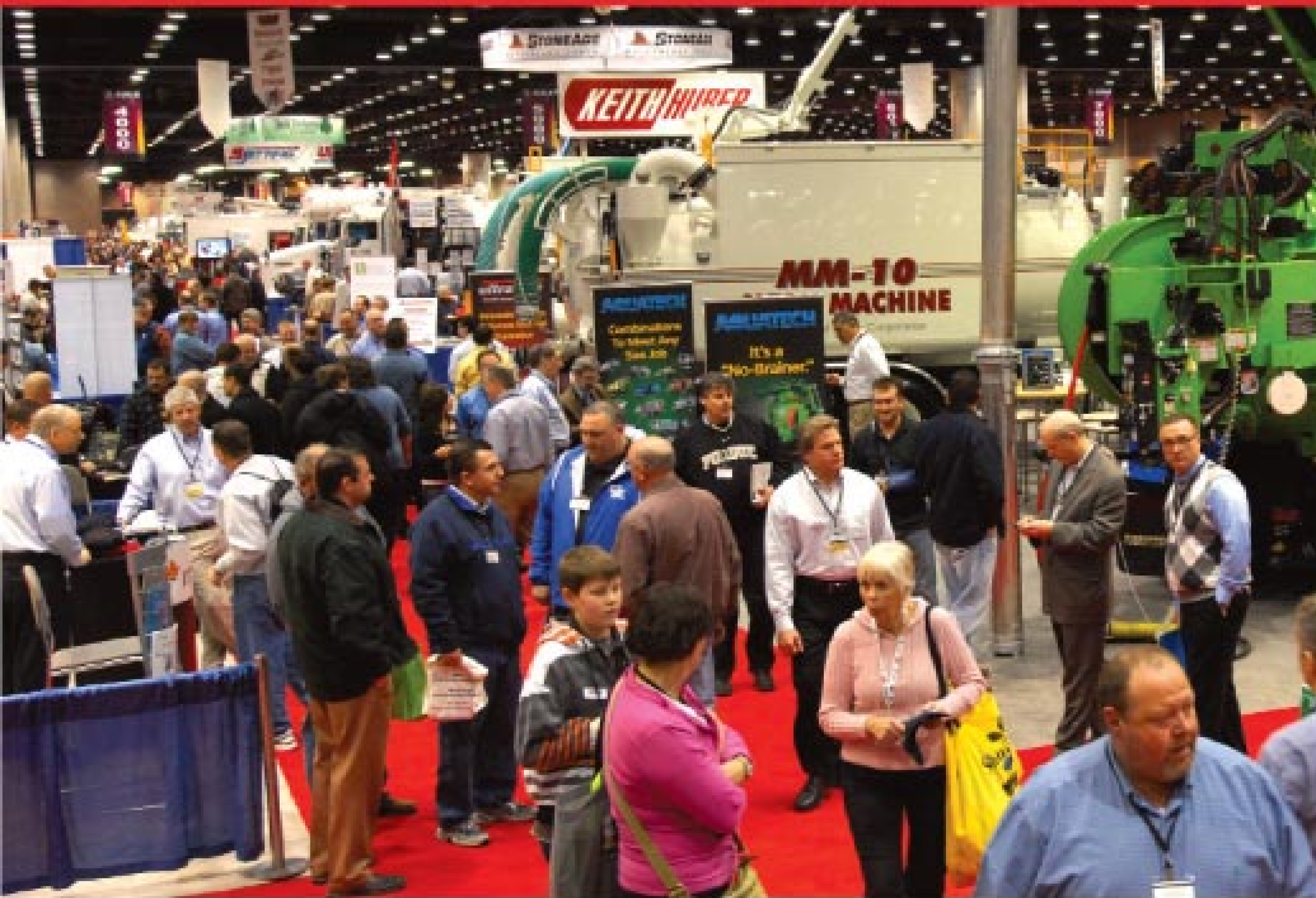

## EDUCATION DAY

**WEDNESDAY**  
MARCH 2, 2011

- Over 60 unique seminars
- A great way to fulfill your Continuing Education requirements!
- Additional seminars Thursday and Friday

## EXHIBITS

**THURSDAY, FRIDAY, SATURDAY**  
MARCH 3 - 5, 2011

- More than 500 Exhibiting Companies
- Over 500,000 Square Feet of Exhibit Space!

ONLY  
**\$40.00**  
PER PERSON

WHEN YOU  
**REGISTER BY**  
JANUARY 21ST, 2011

@  
**WWW.PUMPERSHOW.COM**

**OR CALL**  
**866-933-2653**  
TO MAKE YOUR  
RESERVATION BY PHONE



# MID-STATE TANK

A.S.M.E. Certified / D.O.T. Approved  
UL-142 Listed

Tanks for  
your Business



Mid-State Tank Co., Inc.  
P.O. Box 317  
Sullivan, IL 61951  
Telephone: 800-722-8384  
Fax: 217-728-8384

[www.midstatetank.com](http://www.midstatetank.com)



Mid-State Tank manufactures dependable stainless steel and aluminum pressure / vacuum tanks for the septic and portable trucks. Semi trailers are a recent addition to our fine line of tank models.

Contact:

Don or Gene for a quote or check on stock tanks



**CHASSIS:** 2008 International, Model 4300, DT466, 210 Horsepower @ 560 lb ft Torque, Allison Automatic 2100 (RDS) 5 Speed, 8000 lb Front Axles w/15x4 Brakes, 17,500 lb Rear Axle /16.5 x 7 Brakes, 10,500 lb Rear Springs w/4500 lb Auxiliary Springs, Air Brakes, 13.2 CFM Air Compressor, Air Dryer, Air Ride Seat, Air Conditioning, Tilt Steering & AM/FM Cassette.

**TANK:** 2008 Amthor, 2000 Gallon, (2) Compartment 1500 Gallon Waste & 500 Gallon Fresh Water, (2) Tank Mounted Tool Boxes, Hose Tray On Each Side And Across The Rear, Aluminum (2 Restroom) Carrier, Reese Hitch & 7-Way Plug, 3" Inlet on Driver's Side w/Hose Hook, 4" Outlet w/Valve-Camlock & Cap, (2) 5" Sight Glasses, 4" Water Fill, 20" Manway (Waste) w/Primary Shutoff, LED Lighting, (4) Worklights w/(2) Switches in the Cab.

**PUMP SYSTEM:** Chelsea Hot Shift Power Take Off, 1-1/8 Hex PTO Shaft, Juroop PWS4 w/265 CFM, 90° Gearbox, Secondary Shutoff w/Moisture Trap, Final Filter, Horizontal Muffler, MORO DC10SS 20 GPM Washdown Pump, Hannay Hose Reel, 50'x1/2" Washdown Hose w/Hose w/Nozzle, 50' x 2" Hose w/Valve & Aluminum Pickup Tube.



Phoenix Industries &  
Apparatus, Inc.

Complete  
Tank Truck &  
Trailer Service &  
Testing Facilities

**NEW UNIT LEFTOVER  
MUST MOVE**

## New & Used Tank Truck & Trailer Sales

Where Quality Work Is a Habit, Not an Effort

Phone: (513) 722-1085 • (800) DOT-TANK  
(513) 722-1535 fax • [www.phoenixdottank.com](http://www.phoenixdottank.com)  
6466 Snider Rd. • Loveland, OH 45140

## SHOWER TRAILERS DISASTER RELIEF - ARE YOU PREPARED?

Call Now  
To Be Included As A  
Preferred  
Supplier



### Standard Options

- Includes LPG Heat On Demand Water Heaters
- Private Showers
- Changing Area with Optional Bench
- Water Resistant Interior
- Steel Studs & Roof rafters
- Exhaust fans

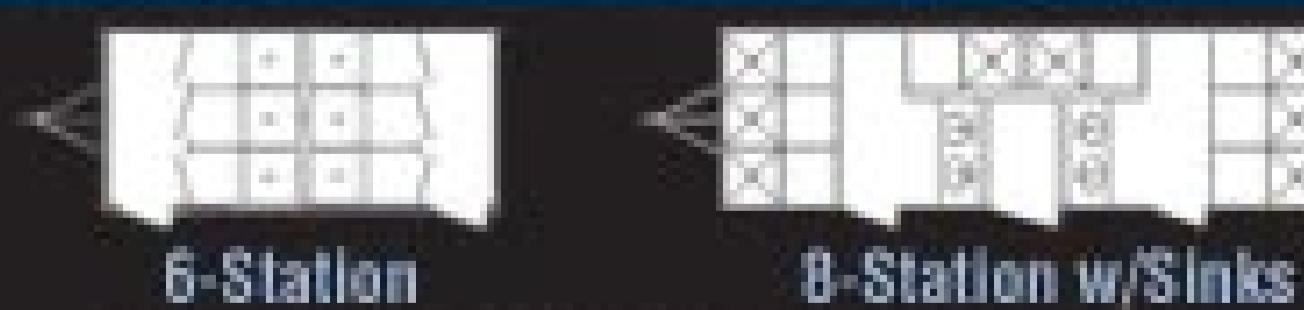

*Comforts of Home*  
Services, Inc.

[info@cohsi.com](mailto:info@cohsi.com) • 877.382.2935 • [www.cohsi.com](http://www.cohsi.com)



**12,000+ Products Online**  
**www.watercannon.com**  
**1.800.964.9274**

WATER CANNON INC  
 4044 W. Lake Mary Blvd  
 Lake Mary, FL 32746-2012



**Factory Hours**  
**7AM - 7PM E.S.T.**  
**We Ship Fast !**



**Air Freight Deadline 6PM E.S.T.**  
**1-800-454-9274 Open Until 7PM E.S.T.**

**40,000**  
**products available**



50'  
\$39.99

4000PSI  
\$11.99

4000PSI  
\$39.99

Pumps  
\$69.99 +

150'  
\$79.99

**Blue Clean Power**

**Surface Cleaners**

**Homeowner Pumps**

**Axial Pumps**

**HONDA Engines**



**40,000 Products In Stock Including Brand Name Pump Repair Kits, Replacement Items,  
 Hard To Find Options & Low Price Complete Packages**

**THE ORIGINAL WATER CANNON COOL DECK FRAMES \* LIFETIME FRAME WARRANTY**



6.5HP WCA008 **\$89**  
 13HP WCA030 **\$99**  
 24HP WCA040 **\$139**



6.5HP WCA009 **\$114**  
 13HP WCA031 **\$119**  
 24HP WCA041 **\$159**



13HP WCA060 **\$169**  
 24HP WCA063 **\$199**

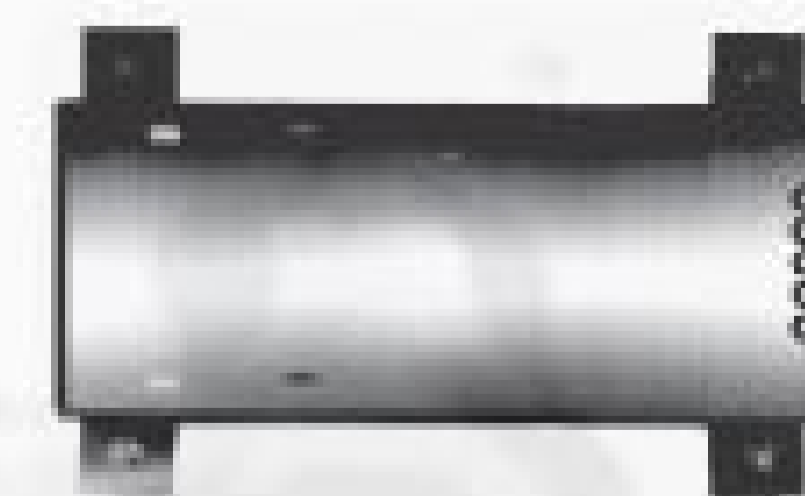

6.5HP WCA075 **\$49**  
 13HP WCA076 **\$54**  
 24HP WCA077 **\$89**



Up to 40HP WCA080 **\$319**  
 3-3/4" Cover WCA085 **\$58**  
 3" Cover WCA086 **\$54**

**Serving The Rental & Construction Industries Since 1981**

# Promoting Portable Sanitation in India

**RAJEEV KHER UTILIZES AMERICAN CLEANLINESS STANDARDS AND TOP INDUSTRY TECHNOLOGY TO ENCOURAGE PORTABLE RESTROOM USAGE IN A NEW FRONTIER**

**R**ajeev Kher, 28, is on a quest to bring sanitation standards to his native India. And that's quite a challenge when you realize that 90 percent of Indians living outside major cities still relieve themselves in the open.

Kher first saw portable restrooms being used while working in Canada in 1997. He felt introducing portable sanitation was essential for India, which was — and still is — plagued by health problems related to open defecation in poor settlements and urban slums. He knew that until basic sanitation issues were solved, there could be no significant residential or commercial development in his homeland.

So, in 1999, he established a portable sanitation company in India, Shramik Sanitation Systems/3S. Later that year, he sold the brand to Saraplast Pvt. Ltd. As managing director, Kher holds 65 percent of the shares in this merged company, headquartered about 60 miles southeast of Mumbai (Bombay).

Efforts to raise standards of portable sanitation brought Kher to the 2010 Pumper & Cleaner Environmental Expo International in Louisville, where he learned about the latest industry technologies. *Pumper* caught up with Kher after his Expo visit to find out how he markets portable sanitation on a new frontier for the industry.

## Pumper Interview

By Mary Shafer

**Pumper:** What's the sanitation challenge in India?

**Kher:** In all Indian cities, people do use toilets and there are adequate facilities in private homes. The problem is a lack of public sanita-



These are examples of attention-grabbing graphics used on units placed by Indian company Saraplast Pvt. Ltd. (Photos courtesy of Rajeev Kher)



**“THE PORTABLES OPPORTUNITY IN INDIA IS SO BIG THAT 10-20 LARGE PORTABLE SANITATION COMPANIES CAN EASILY OPERATE WITHOUT TREADING ON EACH OTHER’S TOES. FURTHERMORE, COMPETITION IS COMPLIMENTARY TO THE BUSINESS. IT WOULD HELP BRING IN REGULATION AND INCREASE AWARENESS MORE RAPIDLY THAN A SINGLE ORGANIZATION CAN.”**

**Rajeev Kher**

tion. It's exacerbated by the large migration of rural populations that brings millions of people to the cities, which do not have the infrastructure to handle this influx. As a result, there are problems with water, sanitation, power, etc. We saw that, from a sanitation standpoint, India was an untapped, disorganized market.

**Pumper:** What is your mission?

**Kher:** We wish to ensure that each Indian has access to a clean restroom, and to provide our cleaning technicians with a sense of dignity about their work, which people in the sanitation business currently lack. This is our main challenge. Not only are we looking at portable restrooms, but providing sanitation to everyone. We use the profits generated from our paying work to provide portables in the slums, as well as at public events. The larger aim is to promote, build and service permanent hygienic facilities in homes, businesses and institutions.

**Pumper:** How many individual restrooms do you have, and how many vacuum trucks do you use?

**Kher:** We manage about 2,400 restrooms, doing about 12,000 services per week using around 30 service trucks. This includes service to units we own and others we have sold, as well as septic tanks and bathrooms.

**Pumper:** Your Web site refers to units as “toilet cabins,” and you offer them in Western and Indian style. What's the difference?

**Kher:** The Western cabins have a Western-style commode and the Indian style is the squat type with no commode. In India, the majority of people we cater to — 90 percent of our restrooms are used by migrant labor and construction workers — primarily prefer the Indian squat style unit,





Attendants (left) watch over restrooms placed at an event.

Below, a squat-style restroom preferred by users in India is being assembled.



also called Turkish toilets. Another difference is that in India, toilet paper is not used much. Most people use water to wash themselves when they're finished.

**Pumper:** Does Shramik operate on the same rental model as its counterparts in the United States?

**Kher:** The system pretty much works the same, but we don't call it rental. It is a pure service model. The unit is installed for free, and we charge for the cleaning and evacuation of waste. We do make some profit due to our volume of customers. However, our aim is not just profit, it is achieving what we call "Total Sanitation" — organizational growth for the people and the company, for society.

**Pumper:** How did you get your first construction customer, and how much do you charge for the service?

**Kher:** I had to convince a site manager to use my restroom and had to give complimentary service for a month or so. At the end of the period when the time to pick up the restrooms came, the customer — seeing the tangible benefits of the service — agreed to pay. He realized the units were responsible for a good, clean and hygienic facility. Also, most builders and promoters did realize that the dignity of workers had been neglected and this was a major area of concern. They realized that these most basic of facilities improved worker morale and, above all, saved a lot of time and headaches, since the cleaning responsibility was completely outsourced to us.

We then mutually arrived at a price and fixed it as a standard price for all construction sites in the vicinity. Our monthly charge varies from location to location, as it depends upon several factors such as distance from the sewage treatment plant, number of units, type of client and other factors.

**Pumper:** Are you concerned about competitors moving in, now that you've paved the way?

**Kher:** No, I welcome it. The portables opportunity in India is so big that 10-20 large portable sanitation companies can easily operate without treading on each other's toes. Furthermore, competition is complimentary to the business. It would help bring in regulation and increase awareness more rapidly than a single organization can. It would set better standards. We are on the lookout for tie-ins and joint ventures with

international organizations, to share local knowledge to build the portable sanitation sector in India.

**Pumper:** Many Westerners believe developing countries use outmoded, polluting technologies. But you talk about modern, sustainable practices. Explain.

**Kher:** What the Western world believes was true a decade ago, but the situation is rapidly changing. We are increasingly seeing the government, corporations and even end users becoming environmentally conscious.

At Saraplast, we use the most modern techniques, on par with the Western world. Our entire business voluntarily follows guidelines prescribed by the PSAI (Portable Sanitation Association International) in our country where there are no regulations on portable sanitation. We have always been looking at green and recyclable business models that have zero negative impact on the environment. All our restrooms are built from recyclable materials, the sanitary concentrate we use is a bio-friendly additive, and all

the waste we collect is disposed of at a sewage treatment plant.

As we grow and develop substantial waste collection, we have plans to set up a biogas facility to generate power and create carbon credits. All our trucks have sophisticated GPS and monitoring systems, and our restrooms have RFID (Radio Frequency Identification). All of these technologies allow us to plan and execute the most efficient service routes and processes and give us the controls and efficiency needed for better documentation and safety.

**Pumper:** What kind of marketing and promotion are used to generate new business in a country where people don't understand the portable restroom concept?

**Kher:** Our sales teams go to construction sites where they show groups of temporary workers the value of good sanitation using graphic flip charts, since people are mostly illiterate and understand through pictures. Our promotion activities create a demand for our services from the laborers. We also do direct marketing in slums, talking to women and young children about the benefits of using restrooms and the disadvantages of defecating in the open. We talk to tourism departments about how they'd attract more tourists if they could provide clean sanitation facilities that are pleasant to use, and which visitors from most other countries expect.

**Pumper:** What's your growth plan for the next 3-5 years?

**Kher:** We wish to provide more than a million services per week catering to slums, construction sites, disaster management, street (pay-for-use units), tourism and school sanitation. We're also moving into waste management, including disposal and treatment of waste to form energy. We'll even be developing low-cost package treatment plants to offer a Total Sanitation solution. ■

# ST Series Special TANK & PUMP PACKAGE



2300 gallon tank with ST Series tank package

All **ST Series** tank packages share the standard options listed below. Call for a quote today on tank capacities and sizes ranging from 1500 to 5000 gallons.

- 1/4 inch mild steel
- Full length frame rails
- Full length hose trays
- Tank to frame mounting hardware
- 20 inch top hatch
- 25 inch rear hatch
- Curb side tank ladder
- 1 1/2" vacuum relief valve
- 1 1/2" pressure relief valve
- 12 inch primary shut off
- Secondary shut off
- 1/4" steel baffles (2) qty
- 3" intake w/lever valve
- 4" discharge w/lever valve
- Three 5" sight eyes
- Work light kit & LED tail lights
- Rear mounted hose hangers
- Bright white paint

**2300 GALLON TANK with ST tank package \$13,900**  
Call for information on mounting and custom configurations

**HERTELL** Vacuum Pumps  
Over 30 Years Building Percision Pumps



Call for information on other Hertell models, CFMs and pricing

- Hertell Pump Package**
- K-D 8000 286 CFM air cooled pump
  - Heavy duty 1/4" steel pump stand
  - Three shaft heavy duty gearbox
  - Oil catch muffler

**\$4,900**

**Tank & Pump Package Before Discount \$18,800**

**ST Series Special Discount -\$2,000**  
(Limited time offer)

**Act now with this savings advantage to invest in new equipment. \$16,800**

Tank fabrication in mild steel, hot dip galvanized, and stainless steel. Bare tanks to complete trucks.



Experience Matters



# LMT

**CUSTOM TANK FABRICATION**

1105 SE 2nd Street P.O. Box 142 Galva, IL 61434

Ph. 800-545-0174 • 309-932-3311 Fax 309-932-3155  
www.tanksandpumps.com www.pbpumps.com

“Just to let you all know, I did get my new AR-1 today. I played with it in my yard for about half an hour and put it to work this afternoon. I have to tell you this is the best tool I have ever invested in. I look forward to a long-lasting relationship with Prototek.”

Thanks again,

Peter M. Christopher,  
Fairfield County Home Inspection L.L.C.  
Fairfield CT



“You are very welcome, Peter!”

**Prototek**



**ECONOMICAL • EASY 800-541-9123**  
www.prototek.net email: prototeksales@prototek.net

## Dewatering Equipment



**Use The Right Equipment  
To Get The Best Results.**

- Liquid Reduction = Reduced Transportation Costs
- Dewatering = Reduced Tipping Fees
- Non-Organic Separation = Facilitate Land Application of Liquids

**ACCENT**  
MANUFACTURING INC.

Designed for Simplicity. Engineered for Durability.

**Toll Free: 877.855.4890**

info@accentmanufacturing.com • www.accentmanufacturing.com



SAFE-T-FRESH

# LIQUIDS

Syrup • Concentrate • Ready-To-Use

- Deeper Blue Color Improves Coverage
- Longer Lasting Odor Control
- 35% Cost Savings Per Service Over Tablets or Packets
- Increased Fragrance Presence
- Easy-To-Use For Washdown
- Consistent Results

Call your Area Manager or a Deodorizer Specialist today for information about custom blends, bulk pricing, freight programs and available terms.

**877-764-7297**

Visit us online at:  
[www.safetfresh.com](http://www.safetfresh.com)

1 gallon  
6 gallon  
55 gallon  
275 gallon

Earn FREE Products With

**DEODORIZER**  
**ROI**

**SAFE T FRESH**  
Deodorizers

*Protection That Pays™*

A Division of Satellite Industries

**Satellite**

## NOT READY FOR WINTER?

GET PREPARED WITH ALL WEATHER EPDM

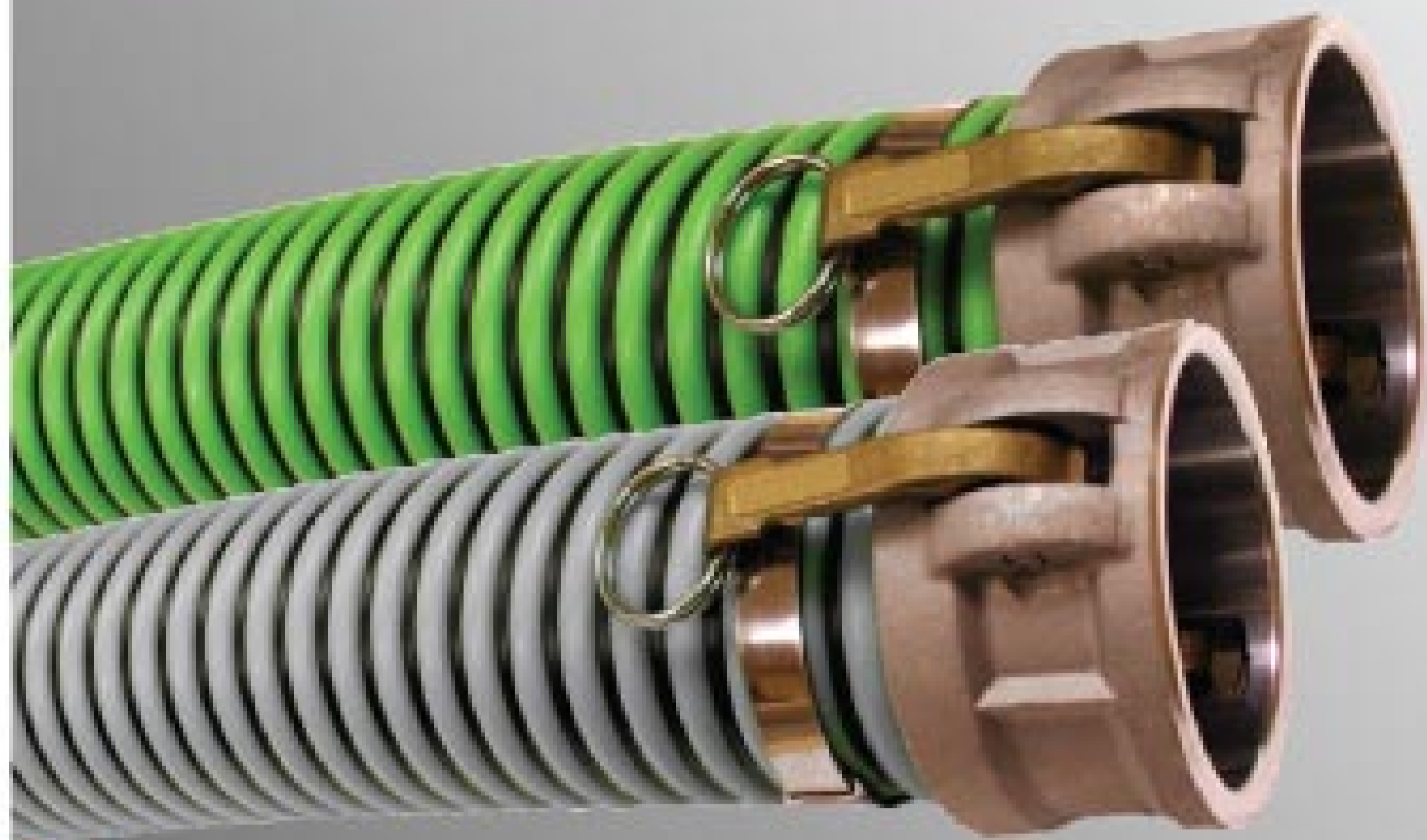

**THE HOSE WITH THE THICK EPDM RUBBER TUBE**  
**3" x 25 FT: \$95.00 EA**  
 COUPLINGS INCLUDED!  
**FLEXIBLE IN COLD CLIMATES**

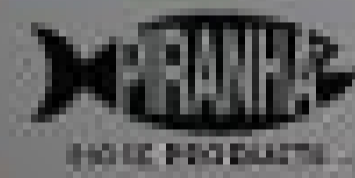

**JETTER HOSE**  
**5% OFF \$200 OR MORE**



**CAPITAL RUBBER CORP**  
**(800) 258-3000**

**WWW.CAPITALLRUBBERCORP.COM**

**435 GALLON VACUUM TANK**



- 1/4" Aluminum Construction
  - Conde Super 6 Pressure Vac Pump with 5.5 hp Honda Electric Start
  - 12 Volt Water Pump
  - 300 Waste/135 Fresh
  - 25' Hose and Wand
  - 2" Sight Eyes in Waste
  - Sight Tube on Fresh Water
  - Completely Self-Contained
  - Ready to Work
- \*OTHER SIZES AVAILABLE\***

**Robinson Septic Service Inc.**

125 Rockrimmon Dr., Bellefonte, PA 16823 • t: 814.353.0263 • email: honeydippers@aol.com

1.800.252.3848 • www.robinsonseptic-service.com



Offering a unique **Insurance program,** designed specifically for the **Portable Sanitation Industry**

**CC Roy Insurance Brokers, Inc.**  
 4305 Hacienda Drive, Suite 550 • Pleasanton, CA 94588  
**(800) 443-6566** • (925) 460-9495 fax  
 sheric@ccroybrokers.com • www.ccroybrokers.com



**CCR**

C C ROY INSURANCE  
 BROKERS, INC.



## Coagulants and Flocculants

for Septic, Grease, Municipalities and Industry



Celebrating **33 YEARS** in business

Save Money • Save Time • Save Polymer

- Dewatering polymers for all dewatering equipment
- All forms: Dry and Emulsion
- Variety of packaging sizes to meet customer needs
- Both East & West coast shipping points
- Expert technical staff
- Specific solutions for our customers

Call Toll-free:  
**877.771.6041**

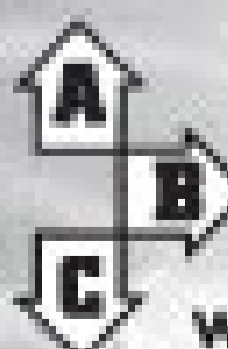

**Aqua Ben Corporation**

1390 N. Manzanita St. • Orange, CA 92867  
 www.aquaben.com • sales@aquaben.com



# Hungry by Design

**Omnivore™ LSG-Series  
the most advanced  
grinder available.**

With new **V-Slice™** cutter technology providing over 370,000 cuts per minute, the Omnivore™ is not only hungry - it's ready to shred anything in its path.

## Liberty Pumps™

**1-800-543-2550**  
[www.libertypumps.com](http://www.libertypumps.com)

Copyright © Liberty Pumps, Inc. 2007. All rights reserved.

# Seasons Change - Dedication Doesn't

- *Stainless Steel*
- *Aluminum*
- *Code & Non-Code*



45 Years of Manufacturing Experience

*Manufacturing*  
Vacuum Trailers for the  
Liquid Transportation Industry

Parts • Repair • Complete Pumping Systems

## 800-589-5254

www.acrotrailer.com • 417.862.1758 • fax 417.862.8084 • 2320 North Packer Road • Springfield, Missouri 65803

# SALE!

**300 Gallon  
Low Profile  
Holding Tank**  
**only \$297**

For a limited time.

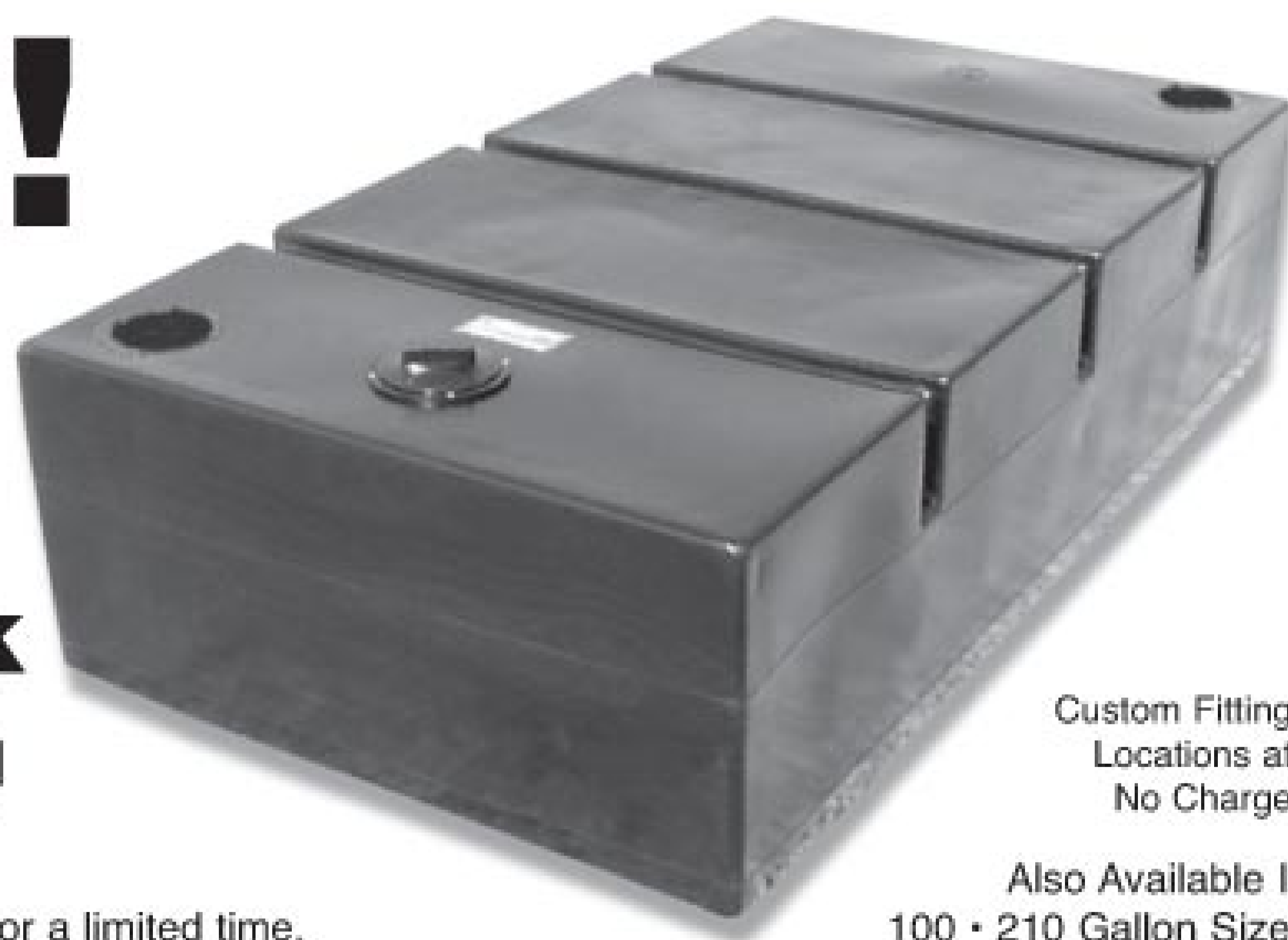

Custom Fitting  
Locations at  
No Charge

Also Available In  
100 • 210 Gallon Sizes



Bulk Storage and Transport Tanks



ShurFlo Pumps  
and Accessories



Ball Valves and  
Cam Lock Couplers

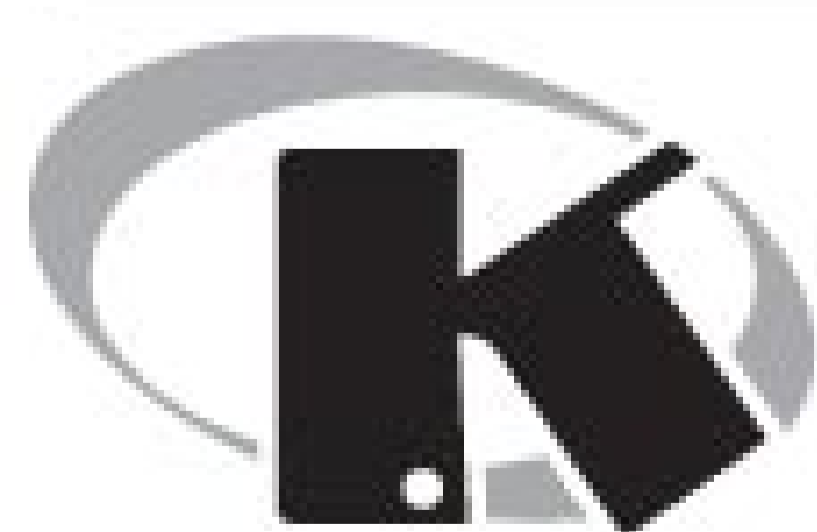

**KentuckyTank**  
Plastic Tanks and Accessories

**1-888-459-8265**

www.kentuckytank.com

## MEGA Holding Tank

1275 and 1600  
Gallon Size

### Options

- Lockable Lid
- Level Alarm
- Custom Fittings



**NORWESCO**

Distributor Since 1987

Nationwide Shipping Points



# New.



**ENVIRONMENTAL**

## Introducing the Newest Member of the Zoeller Family of Water Solutions

When your needs include decentralized wastewater solutions that are environmentally sound and require innovative technologies, contact the Clarus team. Our depth of experience in providing onsite products and solutions will meet and exceed the demands of your application.



**ENVIRONMENTAL**

*Zoeller Family of Water Solutions™*

*Clarus Environmental is now seeking  
Distributors and Master Agents.  
Please call 877-244-9340 for  
more information.*

[www.clarusenvironmental.com](http://www.clarusenvironmental.com) 877-244-9340

# Meter Reader

## FACED WITH A PROBLEM CUSTOMER, A PUMPER LOOKS FOR AN EFFICIENT WAY TO TRACK USAGE OF A FAILING SEPTIC SYSTEM

*This feature in Pumper reports noteworthy conversations that take place in Pumper Discussion, an e-mail based forum for industry professionals sponsored by COLE Publishing. Pumper Discussion provides for the exchange of information and ideas on septic and drainfield installation and maintenance, trucks and equipment, portable sanitation, chemical and additives, and much more. To find out more about Pumper Discussion, or to subscribe, visit [www.pumper.com](http://www.pumper.com).*

*Information and advice in Overheard Online is offered in good faith by industry professionals. However, readers should consult in depth with appropriate industry sources before applying such advice to a specific business situation.*

## Overheard Online

### Question:

Does anyone know of a flow meter that can measure the flow at the inlet of a septic tank? I have a customer with a failing drainfield who told me that she was the only person living in her house. She didn't have the money to tap onto sewer or replace the drainfield. I told her that I believed if I jetted the lines and put a heavy dose of bacteria into them it would probably work for her. After I finished everything, her son came home and (surprise!) it turned out he lived there full time as well. It has been working for a while but she called a few days ago and said it's failing again. I went out there and (surprise!) it turns out there were three people living there and I suspect that she is babysitting the grandkids all day too. Now she is complaining and wants her money back. I would like to have some way to document her water usage if she complains to the health department.

### Answers:

Can't this be measured at the water meter? I have never seen what you are talking about, but it seems that the amount read by the water meter would be the amount that goes into the tank ... unless they are pulling a lot of water that does not go down the drain. If that is the case, an inline water meter can be put on a hose so that amount can be tracked and deducted from the water meter amount.

We have installed an open channel (pipe) flow meter, mostly on municipal sewer lines. They can be costly, and if you only need to measure short term, I think they can be rented or a company may offer this service.



*Pumper welcomes letters from readers responding to articles we publish or offering comments and opinions of interest to the industry. You can submit your letter by:*

**MAIL: Pumper, P.O. Box 220, Three Lakes, WI 54562**  
**FAX: 715/546-3786 ■ E-MAIL: [editor@pumper.com](mailto:editor@pumper.com)**

*All letters must be signed. Please limit your letter to 500 words or less. We reserve the right to edit all letters for length and clarity.*

“Perhaps you could get a big job from a small one. If her system is (shot), it will need replacing, and it might as well be you who does it.”

I'm just an old guy with old-fashioned ways, but if I wanted to know the flow, I would pump the tank completely and then measure the inches of water every day or two.

Has anyone checked the toilet and other fixtures to make sure there are no leaks? Perhaps they can switch to a 2.5-gpm showerhead and an ultra low-flow toilet to reduce some of the demand on the system. Document what you've done; send them a letter recommending they check their fixtures for leaks, etc. If they keep pestering you, let them know that you need to send copies of everything to the county to protect your reputation. Remind them that they may be creating a health hazard.

Is the tank leaking? Is the tank buried within the water table? How old is the drainfield?

The tank is not leaking yet. I suspect it might eventually because the grass at the outlet is lush and green with other tall weeds growing while the rest of the yard is pretty brown. For now though it is just flushing slow and gurgling. I would just empty the tank and time how long it takes to fill up, but they aren't going to pay me for that.

The drainfield's age isn't really known. There are permits on record for repairs in 1991, 1995, 1998, 2001 and maybe a replacement in 2005. The health department doesn't know if it was replaced; the permit doesn't say. But there is multi-pipe in the ground and that wasn't around when the house was built 25-30 years ago.

Why don't you offer to replace her drainfield and take the previous bill or a portion of it off that total? Perhaps you could get a big job from a small one. If her system is (shot), it will need replacing, and it might as well be you who does it. So eat a little crow to keep your customer, and keep your eye on the bigger picture.

With all those permits/repairs, it sounds like she plays the “system.” She doesn't want to do the job right (or at least at her expense), is looking for the “just squeak by” patches in life, and, unfortunately you happen to be the latest nice guy to come along. Document everything, and wait it out. She'll probably just move on to someone else with the same sob story. ■

# TankTec

Tank Technologies & Supply Co. LLC

Portable Restroom Service Trucks  
 Septic, Grease & Grit Trucks  
 Refined Fuel Trucks  
 Slide-In Tanks  
 Pumps, Parts & Accessories

**www.tanktec.biz 888.428.6422**

In Stock or Custom Built • Finance and Lease Options  
 Aluminum or Stainless Steel • 300-6000 Gallon • Trailers  
 Portable Restroom Service Trucks In Stock  
 Single and Tandem Axle Vacuum Trucks In Stock

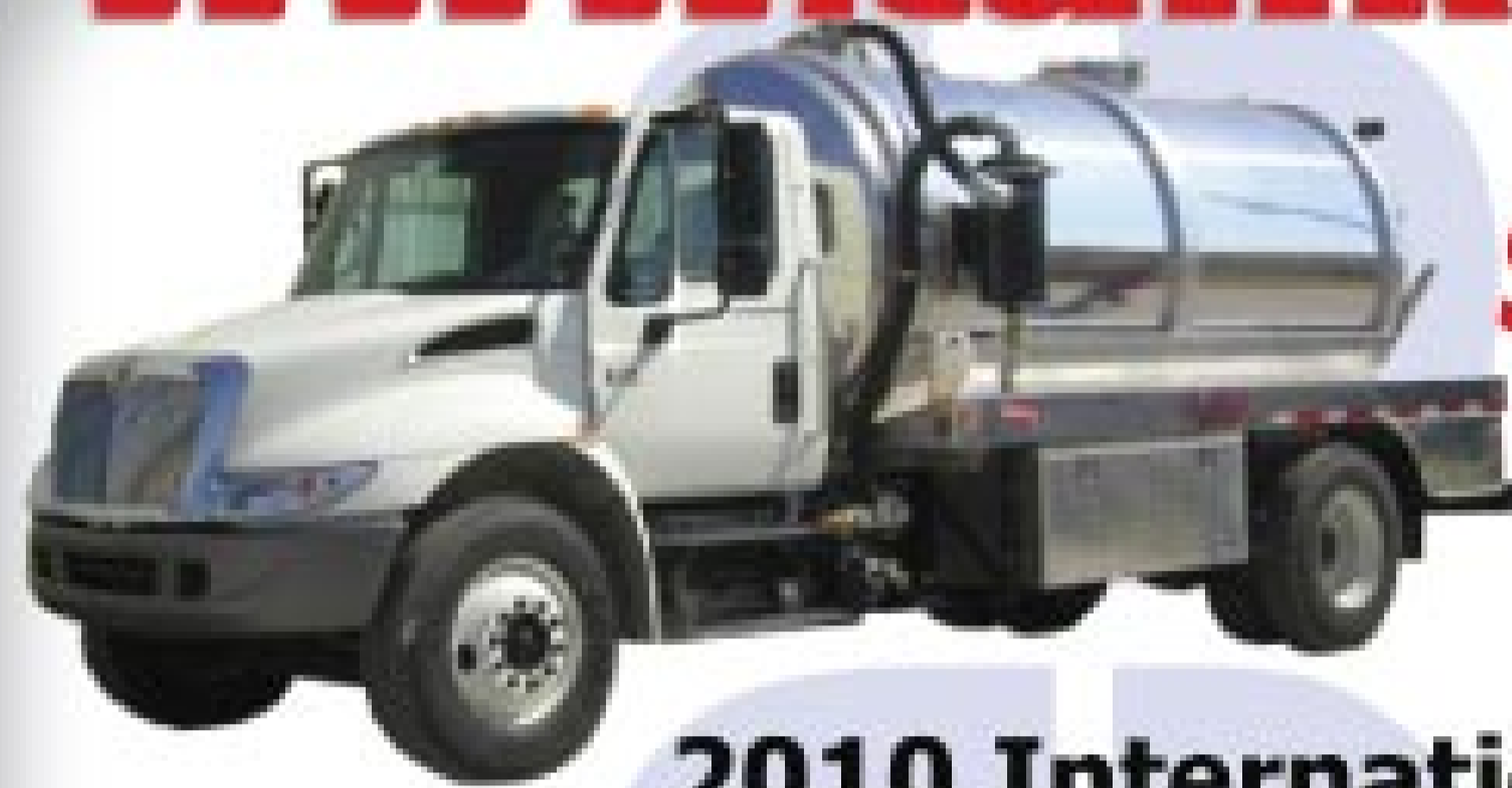

**\$88,875**

## 2010 International 4300 M7 2200 Gallon Aluminum Tank

M7 motor • Manual trans • 33,000 # GVW • Diff lock  
 Masport HXL75 230 cfm • 3" inlet • 4" dump • Toolbox



**\$87,450**

## 2010 International 4300 M7 2000 Gallon Aluminum Tank

Portable restroom service truck  
 Masport HXL4V • 158 cfm pump system  
 Stainless DC-10 fresh water pump  
 Stainless steel tank also available



International  
 MaxxForce7:  
 LESS cost,  
 LESS fuel consumption,  
 LESS noise level,  
 LESS maintenance,  
 MORE money in your pocket!

visit [www.tanktec.biz/M7](http://www.tanktec.biz/M7) for more info

**MAXXFORCE 7**  
 INTERNATIONAL DIESEL POWER™



**\$122,900**  
 plus FET

## 2011 International 7500 4200 gallon aluminum tank

350 hp • 1150 tq • 10-speed • 18k front • 40k rear  
 NVE Max Pax 866 500 cfm pump • 4" inlets • 6" dump

## Slide In Tanks!

300 Gallon (200/100 split)	\$7200 (Conde pump)
450 Gallon (300/150 split)	\$7800 (Conde pump)
550 Gallon (370/180 split)	\$9400 (Conde pump)
***Add \$900 for Honda 9hp and Masport 106 cfm pump	

**Completely Self-Contained and Ready to Work!**  
 Single Compartment and Custom  
 Configurations Available

Aluminum Construction  
 Also Available in Steel and  
 Stainless Steel  
 Honda Gas Motor  
 (5.5 hp or 9 hp)  
 Conde 70 cfm or  
 Masport 106 cfm Pump  
 Whale Water Pump



4x2 from  
**\$73,150**  
 4x4 from  
**\$78,450**

## 2011 Ford F550

F450 4x2 **1250 Gallon Aluminum Tank**

1000 gallon from **\$59,850** Portable restroom service truck  
 Masport HXL4V • 158 cfm pump system  
 Stainless DC-10 fresh water pump  
 Stainless steel tank also available

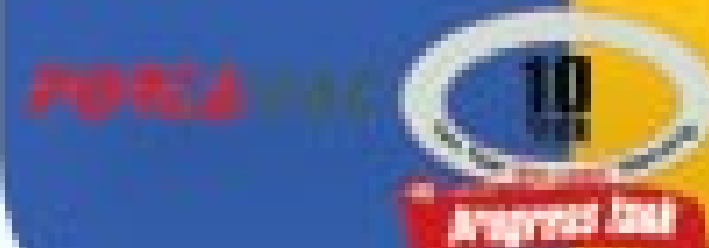
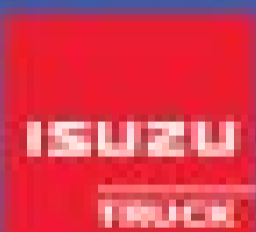

ALUMATANK

Steve Nelson • [snelson@tanktec.biz](mailto:snelson@tanktec.biz)  
 Andy Nelson • [anelson@tanktec.biz](mailto:anelson@tanktec.biz)

**Tank Technologies & Supply Co. LLC**  
**888.428.6422 • www.tanktec.biz**



Follow us at  
[facebook.com/tanktec](http://facebook.com/tanktec)  
 or [www.tanktec.biz](http://www.tanktec.biz)



We Supply

# TUBING

in ALUMINUM,  
STEEL or PVC

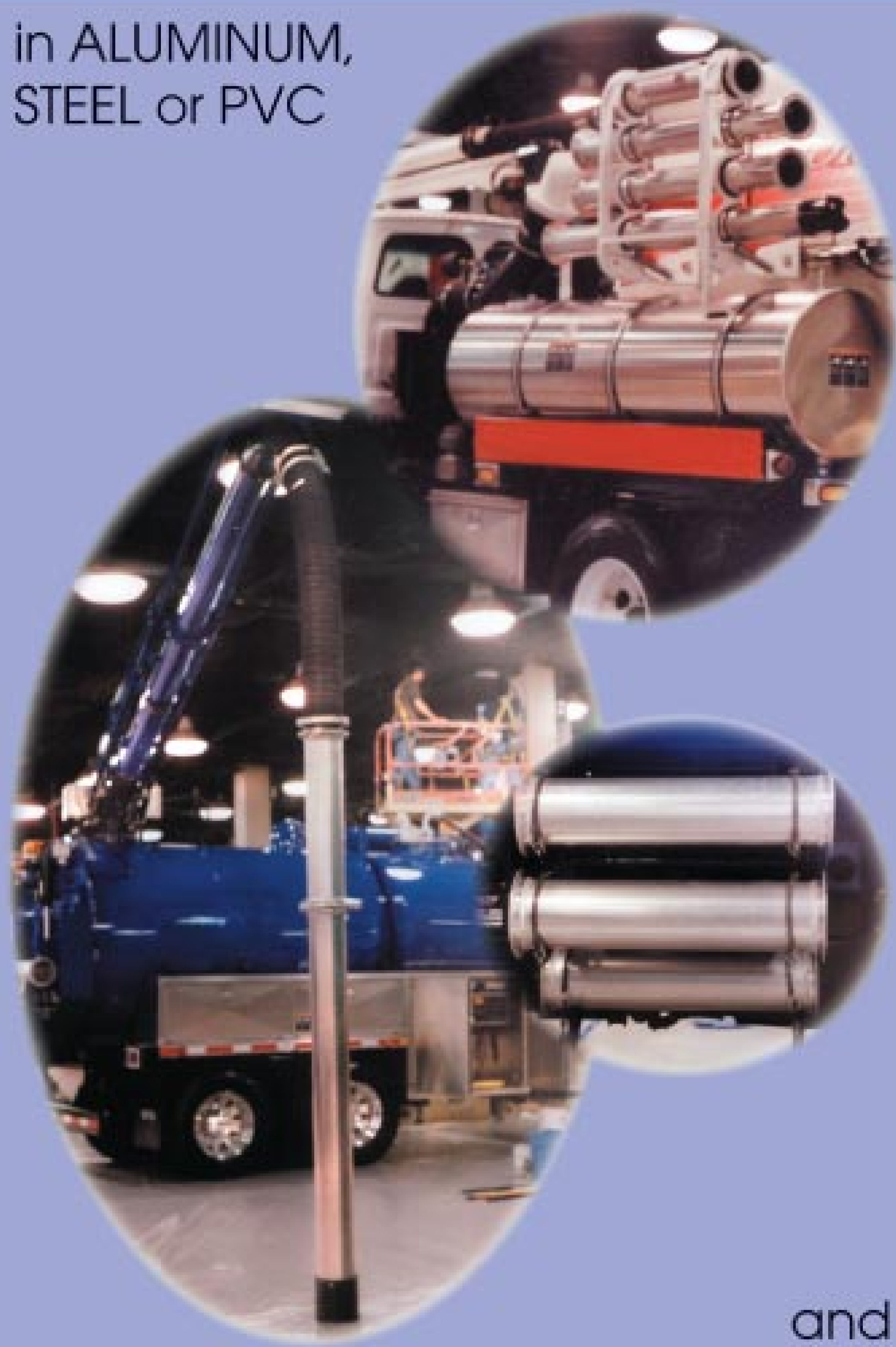

and

# FITTINGS

in ALUMINUM, STEEL, GALVANIZED,  
BLACK STEEL or EPOXY COATED



#### Kroy Manufacturing Plants

**Corporate Headquarters Kroy Industries, Inc.**  
522 West 26th St.  
P.O. Box 309  
York, NE 68467  
Fax: 402-362-6568  
Ph: 402-362-6651 or  
888-477-5769

**Kroy - Ulysses**  
626 S. County Rd. H  
P.O. Box 526  
Ulysses, KS 67880

**Kroy West**  
P.O. Box 1587  
13400 Hanford Armona Rd.  
Hanford, CA 93232

**Kroy Midwest**  
701 S. 17th St.  
P.O. Box 516  
Henderson, NE 68371

## EQUIPMENT FINANCING SOLUTIONS

Stimulate Your Business With



- New and Used Equipment Financing
- Competitive Rates and Terms
- Direct Lender/No Hidden Costs

Webster Capital Finance offers equipment leasing and financing services tailored to the unique requirements of the waste management and environmental industries.

Unlike many traditional lenders, our sales team has expertise in both financing and waste management. We understand the kind of payment plans that make sense for your industry, the equipment, and day-to-day business issues you face.

When you work with Webster Capital Finance, you're teaming up with professionals who understand your business and what it takes to help it grow.

[Webstercapitalfinance.com](http://Webstercapitalfinance.com)

NYSE:WBS

**EAST COAST/WEST COAST**  
Robert Marino  
800.344.2224  
rmarino@webstercapitalfinance.com

**SOUTHERN/SOUTHWEST U.S.**  
George Passarelli  
800.585.9038  
gpassarelli@webstercapitalfinance.com

**MID-ATLANTIC**  
Jim Ellixson  
800.344.2224  
jellixson@webstercapitalfinance.com

**MID-WEST**  
Perry Siler  
800.772-9938  
psiler@webstercapitalfinance.com

**NEW ENGLAND**  
Andy Stephanou  
800.478.8882  
astephanou@webstercapitalfinance.com

**SOUTHEAST**  
Caleb Boyd  
866.247.4654  
cbboyd@webstercapitalfinance.com

All credit products subject to the normal credit approval process.

\* The NYSE ticker symbol of WBS is assigned to Webster Financial Corporation and does not constitute an offer to buy or sell securities by the Company, its subsidiaries or any associated party and is meant purely for informational purposes.

Webster Capital Finance is a service mark of Webster Financial Corporation. The Webster Symbol is registered in the U.S. Patent and Trademark Office. Webster Capital Finance is a subsidiary of Webster Bank, N.A. Member FDIC.





You're looking at the  
**BEST vacuum tank in the industry,**  
 ... and the **guys who guarantee it!**

Find us on  
 Facebook

YouTube

Twitter

LinkedIn



AMTHOR MATADOR RUNABOUT PORTABLE TOILET TRUCK

Brian Amthor, Butch Amthor and Hank Vanderveen



- Full line of septic and round and flat portable restroom vacuum tanks. Available in aluminum, steel or stainless steel. Dumping and ASME options.
- Thickest vacuum tanks in the industry. No external rings and full head baffles.
- Units in stock and ready for immediate delivery.
- In house financing - numerous options, competitive rates.
- 10 year leak free warranty on all of our aluminum vacuum tanks.
- Work directly with the factory that manufactures and assembles each unit.
- Worldwide distribution, American made, family owned.



**Engine and Accessory** (states in red)  
 Miami, FL • (800) 327-5431 • ask for Craig Smith



**Amthor Welding** (states in blue)  
 Gardiner, NY • (800) 926-8467 • ask for Brian Amthor



**Amthor International** (states in gold)  
 Gretna, VA • (252) 293-1284 • cell: (845) 494-0104  
 ask for Hank Vanderveen



Tank Truck Manufacturing & Design Leaders

Gretna, VA • tel: 800.328.6633 www.AmthorInternational.com Amthor: Built for the Miles Ahead

# Quality People Doing Quality Work

## DOT Industrial Vacuum Hoist Units

3000 gallon  
DOT unit.



## Hazardous Waste Unit

3000 Gallon /  
2 compartment  
Hazardous  
Waste Unit.



## Vacuum Septic Units



Aluminum or  
Steel Tanks  
in a Variety  
of Capacities

## Mini Vac Trailers

500 Gallon Rear Open Basin  
Cleaner with  
Blower  
System

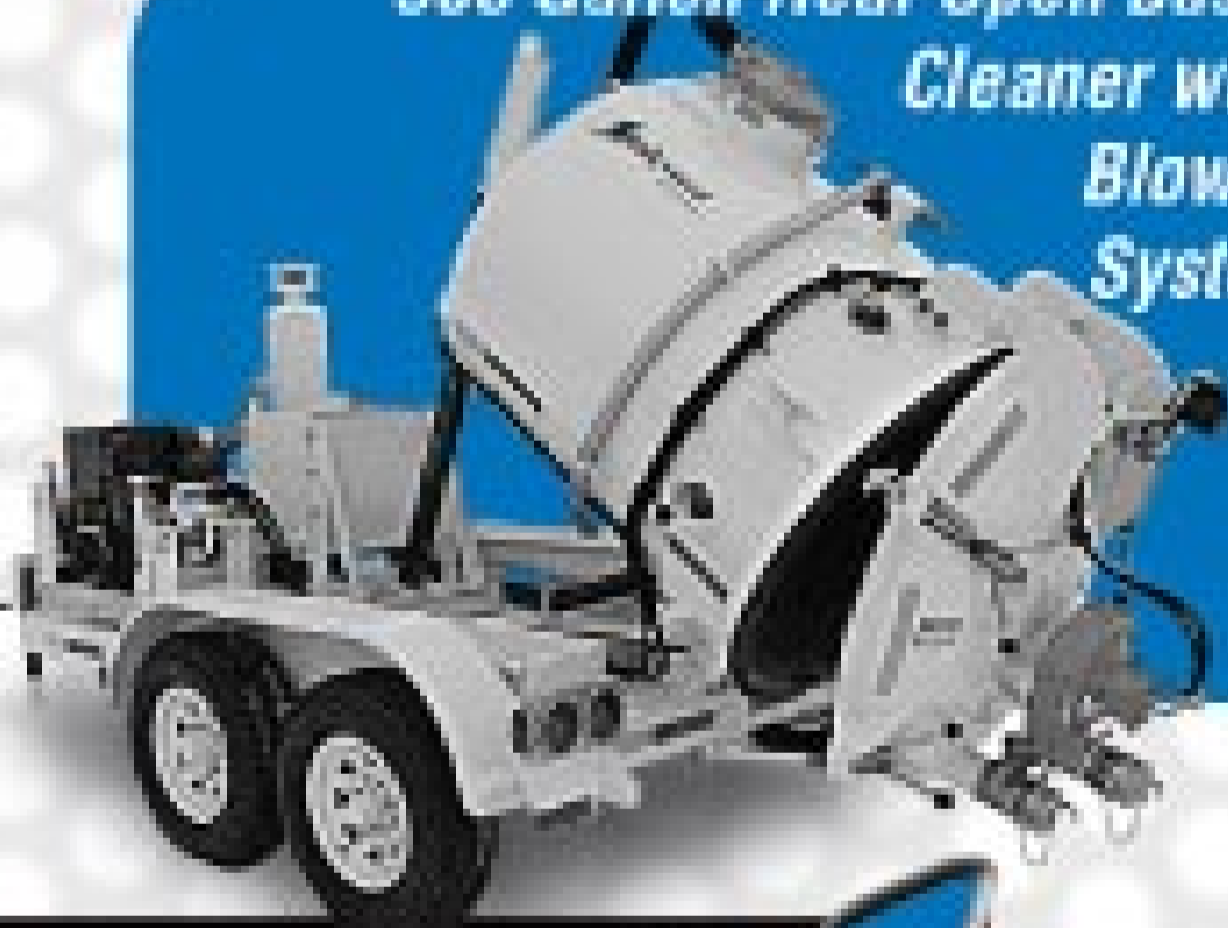

## Slide-In Units



In Stock -  
Slide-In-Portable Restroom Units.  
Call For Details

**INDUSTRIAL**

P.O. Box 1107 - 135 E Mile Road - Kalkaska, MI 49646  
p: 231.258.4870 - f: 231.258.2019 - sales@marshind.com

800.952.1537 - WWW.MARSHIND.COM

Check out the Marsh Industrial facebook page.

See the progress of some of our units in the making.

CALL US TO SEE HOW TO MAKE AN EXTRA \$2,000 PER MONTH



## WHIRLWIND™ AERATOR

The **STA60** and **STA80**  
are specifically designed for  
years of trouble-free service  
and are a superior  
replacement for all 60 and  
80 model pumps on the market.

**Best  
Value!**

STA60 ....\$220    STA80 ....\$250

**CARRIES A 2-YEAR WARRANTY**

## Flagg-Air™ Model 340

HAS BEEN SOLD  
NATIONALLY SINCE 1992  
AND HAS A REPUTATION  
AS THE LEADER IN  
AERATION!

- 3450 rpm
- 1/4 hp, 115V
- Enclosed motor
- Stainless steel shaft
- High impact plastic parts
- Operates quietly
- 2-yr. warranty
- Fits in place of most original manufacturers' units
- Replacement parts available



**Best  
Value!** \$350

The Flagg-Air 340 does not carry the NSF seal. Check local and state regulations for approval in your area.

## WHIRLWIND™



**R-5760 Blower**  
57 cfm.....\$375

## BULLET™

High Head  
Filtered  
Effluent  
Pumps

BP12...12gpm  
\$235  
BP20...20gpm  
\$255

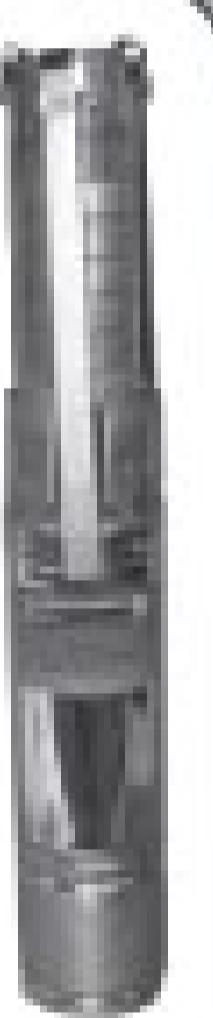

## MEDO HEM LA-80 Linear Pump



with low pressure  
alarm & light,  
with on & off  
switch

## MEDO Piston



LA-60  
LA-80B  
LA-100  
LA-120

## SECOH Diaphragm



EL 60  
EL 80  
EL 100  
EL 120

## GAET

0523  
1023



Rotary Vane  
Compressor

## Regenair® R3105-12 Blower

GAET



Hydromatic,  
Zoeller, ABS,  
Liberty &  
Myers  
Pumps

## Conde SDS 6 Engine Driven



Units available  
20 to  
180 cfm



**Moro PM80**  
Turbo 350 cfm

Moro Pumps: from 176 to 1642 cfm

toll free 1.800.536.5564 • 636.583.5564 • fax 636.583.6432  
e-mail septic@fidnet.com • web www.septicserv.com



**Septic Services, Inc.**





## PORTION CONTROL

**PORTA-PAK®**  
*#1 Portion Control Pak  
 in the World*

**PORTA-TAB®**  
*Holding Tank & Waste  
 Treatment Tablets*

**WE STAND ON SOLID GROUND.**  
*And we go with the flow.*

Deodorizers from Walex in both PORTION CONTROL and LIQUIDS!

## LIQUID DEODORIZERS

**EXODOR® PT-50 SUPREME**  
*The Most Powerful  
 Deodorizer Available*

**BIO-ACTIVE®**  
*Environmentally Friendly  
 Natural Deodorizer*



Whether you prefer portion control or liquid deodorizers, Walex has the industry-leading performance products to fit your portable sanitation needs.

*Just drop it in... or just pour it in. You choose. You can't lose!*



**WALEX**

800.338.3155 | WWW.WALEX.COM

# LEDWELL

## Ledwell Manufactures Full Circle

Servicing the markets of hydro excavation, grease trap remediation, septic, first response clean up and hazardous material containment among others, Ledwell offers you, the operator, solutions in vacuum technology that actually contribute to your bottom line. Call today to speak with a Ledwell representative and discover the full reach of Ledwell Equipment.

**Give us a call.**

The Ledwell technical staff is available to assist you.



Heritage



Conquest



Hurricane

888.533.9355 • [ledwell.com](http://ledwell.com)



## Featured in an article?

# Make the most of it!

### REPRINTS AVAILABLE

We offer:

Full copies of the original magazine

Hard copy color reprints

Electronic reprints

Visit [pumper.com/editorial](http://pumper.com/editorial) for articles and pricing

E-mail [jeffl@colepublishing.com](mailto:jeffl@colepublishing.com)

or call 800-257-7222



# BLUEBUCKS. EARN ON PURCHASES, SPEND LIKE CASH!

## NOW, YOU AUTOMATICALLY EARN BLUEBUCKS ON ALL GREEN WAY PRODUCTS.

5 BlueBucks for every \$100 you spend. Then you can spend your BlueBucks like cash on any Green Way Products deodorizers and cleaners, or PolyPortables equipment. It's our way of saying "Thanks for being a loyal customer".

## SO WHAT WILL YOU DO WITH YOUR BLUEBUCKS?

- Purchase more Green Way Products like deodorizers and cleaners?
- Accumulate toward the purchase of a new restroom or hand-wash station?

- Buy PolyPortables replacement parts?
- Pay down your existing PolyPortables account?

It's your choice! WATCH for your BlueBucks in your next GREEN WAY PRODUCTS invoice.

**PolyPortables – you can build  
a business with us.**



**POLYPORTABLES**

*Listening. Learning. Delivering. Since 1972*

**PORTABLE TOILETS • HANDWASH STATIONS • DEODORIZERS • CLEANERS • TRUCKS**

99 Crafton Drive, Dahlonega, GA 30533 USA • Phone (800) 241-7951 or (706) 864-3776 • Fax (706) 864-8111 • [www.polyportables.com](http://www.polyportables.com)

All Green Way Products' deodorizers, cleaners and air fresheners are high-performance products developed and manufactured in our facilities in Dahlonega, Georgia specifically for portable restroom operators. They are all environmentally safe.



# Ready Duty FOR

By Ed Wodalski



Ford F-750

When it comes time to update your pumping or other work truck fleet, cab and chassis manufacturers offer a variety of rigs to keep you rolling down the road

Is this the year you plan to transfer that old-reliable stainless steel vacuum tank to a new chassis? Or is it time to build a new vacuum rig from the ground up to serve a growing customer list? Maybe you need to beef up the fleet with a medium- to heavy-duty truck to haul equipment from one jobsite to another?

Whatever your needs, truck manufacturers offer a nearly limitless list of features to build a truck that fits your precise needs. You can choose from manual to automated transmissions, hauling capacities and big and beefy braking systems to safely transport any load. Adding to the list of considerations is dealer service, ensuring your truck remains on the road.

Here are the latest cab and chassis combinations that could be the backbone of your next work truck:

## Ford F-750

The 37,000-pound GVWR, medium duty F-750 from **Ford**, available in regular, super and crew cab models, features an ISB Cummins (6.7 liter) ultra-low sulfur turbo diesel engine with choice of Allison automatic, Eaton UltraShift or Fuller and Spicer manual transmissions. Delivering up to 360 hp at 2,800 rpm and 800 lb.-ft. of torque at 1,800 rpm, the F-750 has a curb weight of 8,862 pounds (XLT model). Wheel base (choice of 33 lengths) ranges from 146 to 281 inches. Ford offers 14 cab-to-axle lengths and four chassis heights. Air conditioning and full power ABS brakes are standard. Air-ride seats are available with all hydraulic brake models. Options include power windows, locks and CD/MP3 player. [www.ford.com](http://www.ford.com).

## Volvo VNL Daycab

The VNL Daycab from **Volvo Trucks North America** features the I-Shift, 12-speed, two-pedal, automated manual transmission. Designed to integrate with Volvo's D11, D13 and D16 engines, the I-Shift monitors changes in grade, vehicle speed, torque demand, weight and air resistance. The D13 diesel engine is offered as standard equipment, delivering up to 485 hp and 1,650 lb.-ft. of torque. Cab features include air suspension, ergonomic seats and 50-degree wheel cut for tight turning radius and maneuverability. [www.volvotrucks.us.com](http://www.volvotrucks.us.com).

## International ProStar+

Powered by the urea-free 11- or 13-liter MaxxForce diesel engine, the ProStar+ from **International** delivers up to 475 hp and 1,700 lb.-ft. of torque. Rated up to 37,000 pounds GVW, the ProStar+ has a gross combination weight of up to 110,000 pounds. Up to 7 percent more fuel efficient than its closest competitor according to TMC Type IV tests, transmission choices include the Eaton Fuller 10-, 13-, 15- and 18-speed manual; 10- and 18-speed Eaton Fuller AutoShift manual and the 10-speed Eaton Fuller UltraShift fully automated manual. The optional MaxxForce engine brake by Jacobs offers 351 to 398 of braking horsepower at 1,900 to 2,100 rpm for the MaxxForce 11 and up to 470 of braking horsepower for the MaxxForce 13. [www.internationaltrucks.com](http://www.internationaltrucks.com).



Volvo VNL Daycab



International ProStar+



Mitsubishi Fusco FM330

### Mitsubishi Fusco FM330

The 32,000-pound GVW, cab-forward FM330 from **Mitsubishi Fusco** is powered by a Fusco 6M60 7.5-liter 243-hp, 6-cylinder turbocharged diesel mated to an Allison electronic 5-speed OD automatic transmission or optional 6-speed manual. The 2011 model has an 11,905-pound capacity front axle and 22,485-pound rear axle. Curb weight is 10,220 pounds and turning radius is 57 feet. Air conditioning is standard on the FM330 that is 8 percent quieter than previous models. It also features adjustable seating and Comfort Wave dashboard. [www.mitfuso.com](http://www.mitfuso.com).



Western Star

### Western Star

The 4900 FA and SA, 109-inch BBC model from **Western Star** features the Allison 3000RDS transmission and Detroit Diesel DD13 engine. Engineered for durability and maneuverability, updates include under-hood air cleaner with inside/outside air and dash controls and 6-gallon DEF tank with increased clearance on the back of the cab. The 109 is available with a 12,000- to 20,000-pound front axle and 21,000- to 46,000-pound rear axle. The DD13 engine delivers up to 450 hp, 1,650 lb.-ft. of torque and incorporates Detroit Diesel BlueTec SCR technology. [www.westernstartrucks.com](http://www.westernstartrucks.com).



Kenworth T440

### Kenworth T440

The T440 from **Kenworth** is available as a straight truck or tractor in GVW ratings from 33,000 to 68,000 pounds. Featuring a set-back front axle, tight turning radius and optional automatic transmission, it offers the 260-hp Paccar PX-8 engine with 660 lb.-ft. of torque as standard equipment. A 350-hp PX-8 with 1,000 lb.-ft. of torque and 380-hp Cummins ISL are available. The Eaton Fuller FR013210C 10-speed transmission is standard with 11- and 13-speed Eaton Fuller manual and 5- and 6-speed Allison automatics available. The aluminum cab features an aerodynamic hood. Options include factory installed PTOs, keyless entry, heated mirrors and heavy-duty crossmembers. [www.kenworth.com](http://www.kenworth.com).

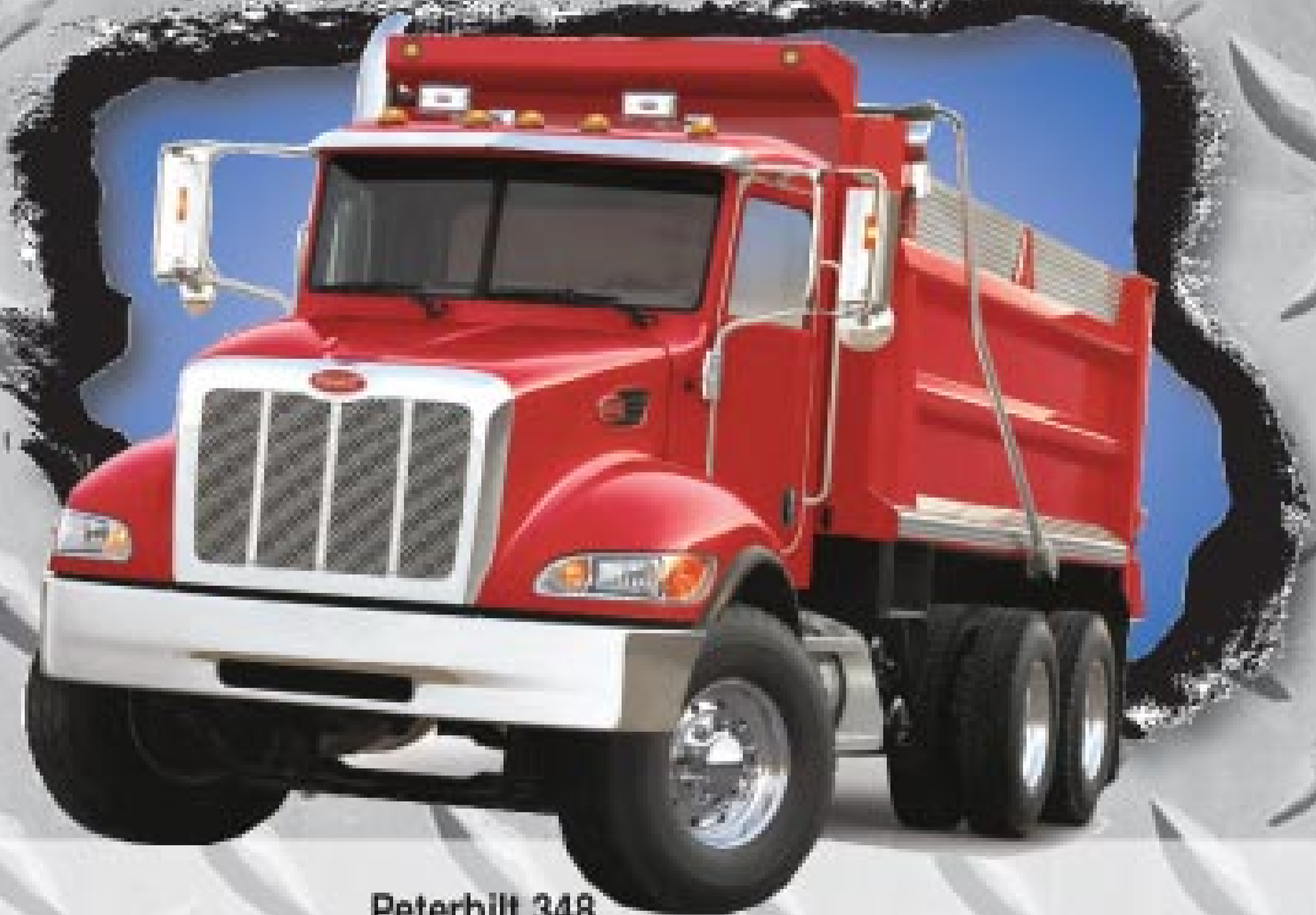

Peterbilt 348

### Peterbilt 348

The model 348 from **Peterbilt**, featuring optional all-wheel drive, is powered by a Paccar PX-8 engine that offers up to 380 hp and can be mated to a Fuller manual (6-, 9-, 10-, 11-speed), Fuller automated (10-speed), Fuller hybrid (6-speed) or Allison automatic (4-, 5-, 6-speed) transmission. Available in either truck or tractor configuration, the 348 has a GVW of 35,000 to 56,000 pounds. Other features include an all-aluminum cab and Metton hood that tilts open 90 degrees. Side window visibility also has been increased 17 percent. [www.peterbilt.com](http://www.peterbilt.com).

## Mack Pinnacle

The **Pinnacle Series** from **Mack Trucks** features the MP7 and MP8 engine with EconoBoost intelligent torque management system that initiates at 1,300 rpm after four seconds of full throttle in the transmission's top two gears, opening up another 200 lb.-ft. of torque for as long as needed. The system disengages once the driver lifts off the throttle. The driveline torque drops to negative when additional power no longer is required, such as when a hill is crested. Mack also rolled out its mDRIVE automated manual transmission this year, offering 12 forward and four reverse speeds. Available in direct drive or overdrive, it has a torque capacity of 1,920 lb.-ft. The driver interacts with the transmission through a dash-mounted control panel containing manual input and hold shift buttons. [www.macktrucks.com](http://www.macktrucks.com).

## Freightliner Business Class M2 106V

Featuring a front engine PTO and front frame extensions, the **Business Class M2 106V** from **Freightliner** is engineered for customization. Recent enhancements include a larger radiator, new hood and improved headlight system. The 1,200-square-inch radiator can accommodate up to 380 hp with automatic transmission and up to 80,000 pounds GVW. The radiator is mounted to the engine and sits above the top of the frame, allowing the PTO shaft to run below the radiator. Composite headlights feature reflectors with halogen bulbs, an upgrade over previous sealed beam headlights. The blend-air engine air intake system pulls air from under and outside the hood, providing ventilation when snow and debris might otherwise restrict flow. Styling updates include an aluminum cab, fiberglass hood and redesigned front fenders. Other standard features include the Cummins ISC diesel engine, torque ratings to 1,050 lb.-ft. and leaf-spring suspension. Transmission choices include Eaton Fuller manual (6, 9, 10 or 11 speeds) and Allison automatic. [www.freightlinertrucks.com](http://www.freightlinertrucks.com).

## Hino 338

The 33,000-pound GVW **Hino 338** for 2011 has a 260-hp, 8-liter J08E-VB diesel engine delivering 660 lb.-ft. of torque at 1,500 rpm. The 6-speed Eaton FS6406A transmission is standard. Options include the Allison 3000 RDS, Allison 2500RDS and Eaton FS6406B. A 12,000-pound front axle and 21,000-pound rear axle are standard. Air-ride suspension and engine idle shutdown are optional. [www.hino.com](http://www.hino.com). ■



Mack Pinnacle



Freightliner  
Business  
Class  
M2 106V



Hino 338

THE LEADER IN PUMPER/CLEANER REELS SINCE 1933

**Hannay Reels**  
The reel leader.

Washdown and Clean Up With Hannay Reels

### Applications

- Power washing
- High pressure washing
- Vehicle and equipment washdown and clean up

### Advantages

- Flexibility of mounted and portable designs
- Hose pickup and storage is quick and neat
- Tried and tested technology
- Tough reels for the toughest environments



Download or call for your FREE catalog  
<http://go.hannay.com/515> 877-467-3357



## Sore Back?

A durable plastic septic lid that fits plastic and concrete risers

THE DUEL POWER LID

Sizes:  
18" • 24" • 30" • 36"

Insulated Lids & Adaptor  
Rings Available



Fergus Power Products

1-800-243-7584 Email [fpproducts@prtcl.com](mailto:fpproducts@prtcl.com) [www.ferguspowerproducts.com](http://www.ferguspowerproducts.com)



# WHEN QUALITY MATTERS

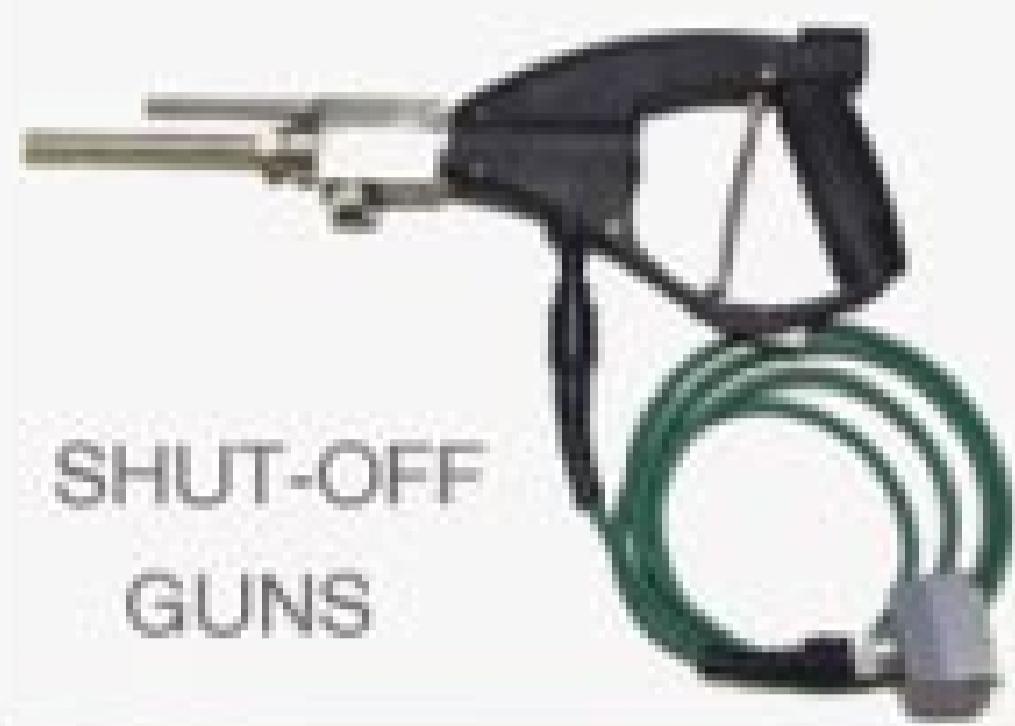

SHUT-OFF  
GUNS

REGULATORS



POWER  
PACKS

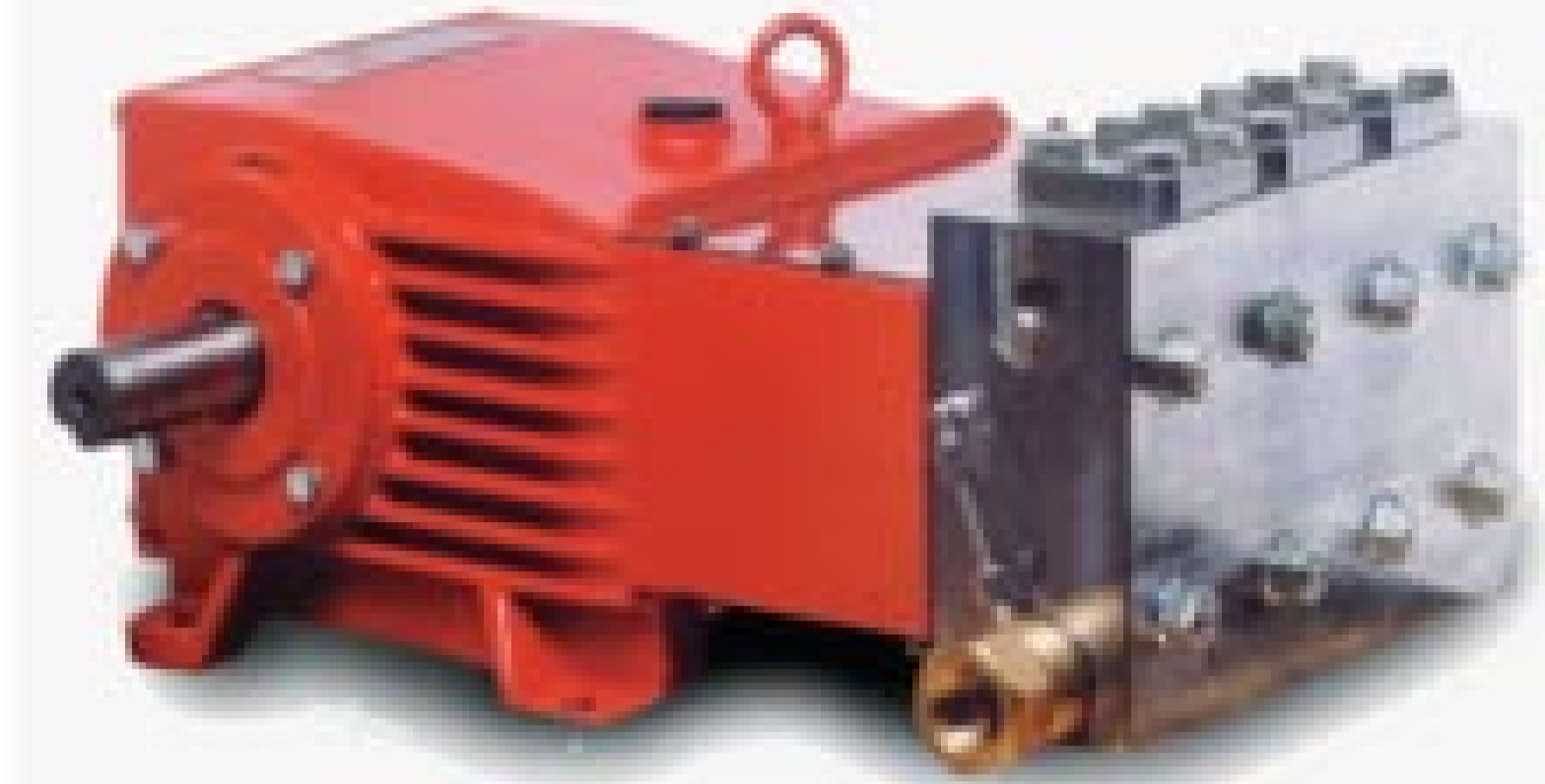

FILTERS

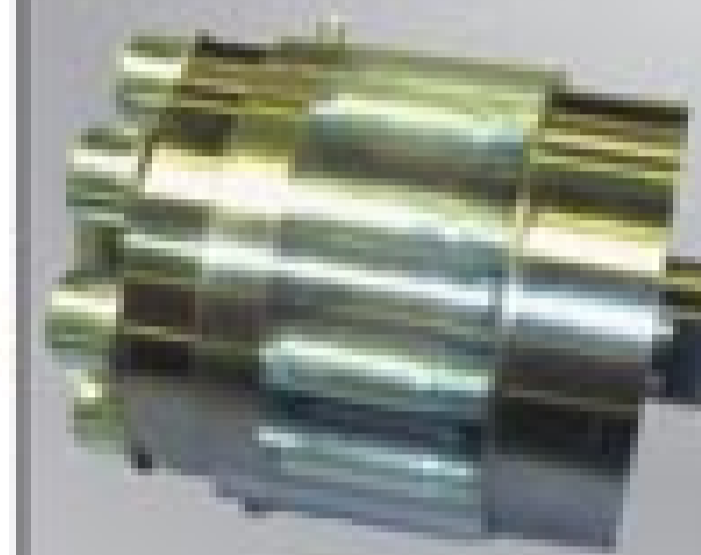

Turbo-Laser

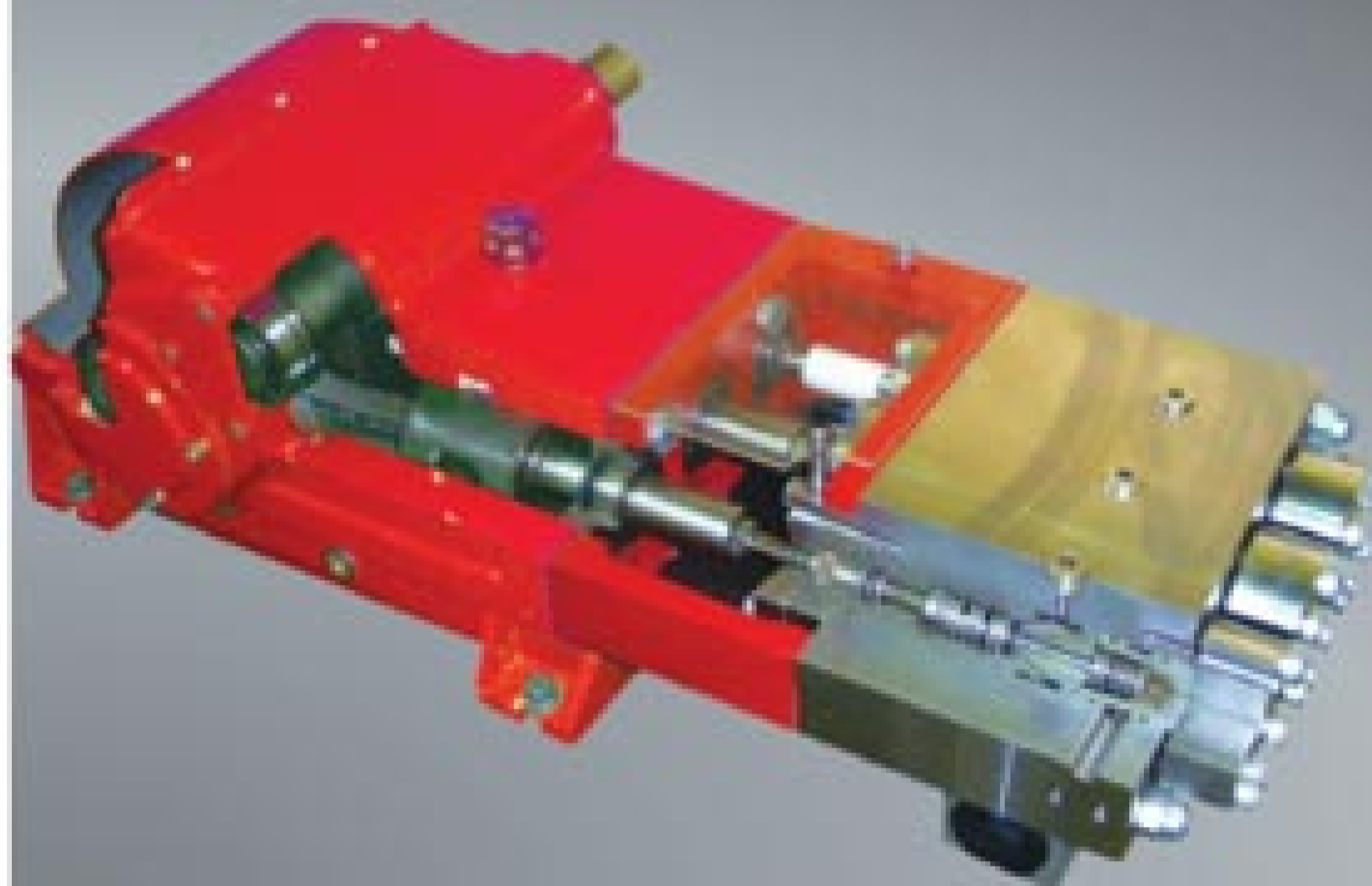

PUMPS



CONTROL VALVES

- **PUMPS**  
Up to 625 GPM  
Up to 50,000 PSI
- **FILTERS**  
Up to 36,250 PSI
- **REGULATORS & CONTROL VALVES**  
Up to 50,000 PSI
- **TURBO LASER**  
Rotating 0° nozzles  
Up to 43,500 PSI
- **SHUT OFF GUNS**  
Up to 43,500 PSI

©Copyright 2010 Giant Industries Inc.

CHOOSE

# GIANT

SEWER CLEANING

INDUSTRIAL PROCESSES

WATER JETTING

[www.giantpumps.com](http://www.giantpumps.com)

900 N. WESTWOOD AVE. TOLEDO OH 43607 PH 419.531.4600 FAX 419.531.6836

# vCamDigital Inspection Systems



## New Modular Control Module

- NEW vCamModular Control Module
- More Storage with new 320GB Hard Drive
- New "Field Serviceable" Reel Terminations
- New "Field Serviceable" Control Module
- Real time recording to SD Card or Hard Drive
- Improved 8" color TFT LCD display
- Rapid file transfer from hard drive or SD to USB Stick
- New range of Camera Skids
- Locatable Sondes on all systems
- Reel range from 100 to 400 feet
- Interchangeable Camera Heads
- Internal Ni-MH rechargeable batteries



## New vCamLSR Range



- New vCamLSR Range
- Camera range from 17mm to 33mm
- 60 feet of 5mm pushrod
- Lightweight and Compact



**Please call for an on-site  
FREE demonstration!**

Vivax-Metrotech Corporation,  
3251 Olcott Street, Santa Clara,  
CA 95054, USA  
Toll Free: +1-800-446-3392  
Tel: +1-408-734-1400  
Fax: +1-408-734-1415  
Website: www.vivax-metrotech.com  
Email: sales@vxmt.com

[www.vivax-metrotech.com](http://www.vivax-metrotech.com)

## 1000 Gallon Trailer Mounted Vacuum System



# EXPERTS IN PORTABLE VACUUM SYSTEMS!

## PACS 1000

PACS trailer mounted vacuum systems are available in a variety of configurations. PACS 1000 is designed for removing liquids, solids, and sludge from land or water. Costing less than vacuum trucks, the PACS is approved for highway towing. Integral hydraulics allow the PACS to run oil skimmers and pumps, as well as lift the tank to dump contents.



**ELASTEC  
All Terrain Vac**

## Oil Skimmer Sucking up money for vacuum trucks

Our Drum Skimmers are optimal for rapid response oil cleanup. Extremely efficient and cost effective, they will give you an edge over competitors.



## DrumIt

The drum filling vacuum head with auto shut off. DrumIt quickly connects to vacuum trucks for a clean interception of debris and liquids.



**ELASTEC**  
AmericanMarine  
Innovative Environmental Products

1309 West Main, Carmi IL 62821 USA  
Tel: (618) 382-2525  
Fax: (618) 382-3610  
E-mail: [elastec@elastec.com](mailto:elastec@elastec.com)



[www.elastec.com](http://www.elastec.com)

PU10/08

# FREE DELIVERY to the P.S.A.I.

## On ANY New Order or Stock Restroom or Septic Service Tank Truck

Portable Sanitation Association International Annual Convention  
Daytona Beach, November 9 through November 13

### 1200 Gallon Restroom Service

Masport HXL4 vacuum pump system, 4 way valve, washdown, remote PTO, toilet carrier.  
2011 Ford 550 or 2011 Dodge 5500

SHOW SPECIAL PRICE! **\$62,225**  
F.O.B. Daytona Beach, FL



### Complete Work-Ready Factory Assembled Units!

#### RESTROOM 25,999 GVW

STK # 1787 1500 Aluminum on 4x4 Dodge 5500 \$76,450  
STK # 1781 1350 Stainless on New 2008 Sterling Bullet \$73,687  
STK # 1806 1500 Aluminum on 2011 Ford 550, 120" C.A. \$74,366

#### RESTROOM 33,000 GVW

STK # 1805 2200 Aluminum, 2009 Ford750XLT, auto. air brakes \$87,050  
STK # 1811 2200 Aluminum, New '07 Freightliner, auto., air \$86,050

#### PUMPER UNITS (SINGLE AXLE):

STK# 1812 2500 Aluminum, NVE 607 MAXPAX, 2011 Navistar M7 \$92,225

#### PUMPER UNITS (TANDEM AXLE):

STK # 1788 3500 Gallon Aluminum - HXL400 - 2009 Sterling \$105,675  
STK # 1791 4200 Gallon Aluminum - NVE866 - 2011 International \$121,125  
STK # 1799 3600 Gallon Aluminum - RFL100 - New '08 International \$114,600

www. **KeeVac**.com



FINANCING DELIVERY CUSTOM BUILDS

# 866-789-9440

# 3 STYLES

## 8 Capacities

IMMEDIATE 'Coast-To-Coast' DELIVERY

Visit Us In  
Daytona Beach  
**P.S.A.I.**  
11/9 thru 11/13/10



New Design!  
**'TANK IN A TANK'**  
Offers improved weight  
distribution!

**\$7,995**  
Plus Freight

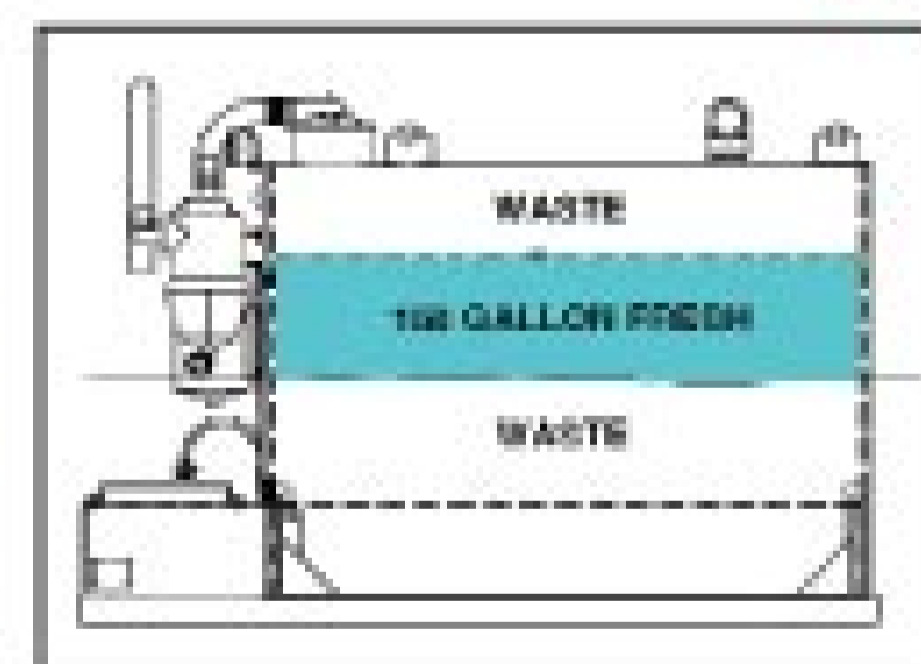

435 Gallon "SpaceSaver"



435 Gallon Rear Engine

450 Gallon 'Tank In A Tank'

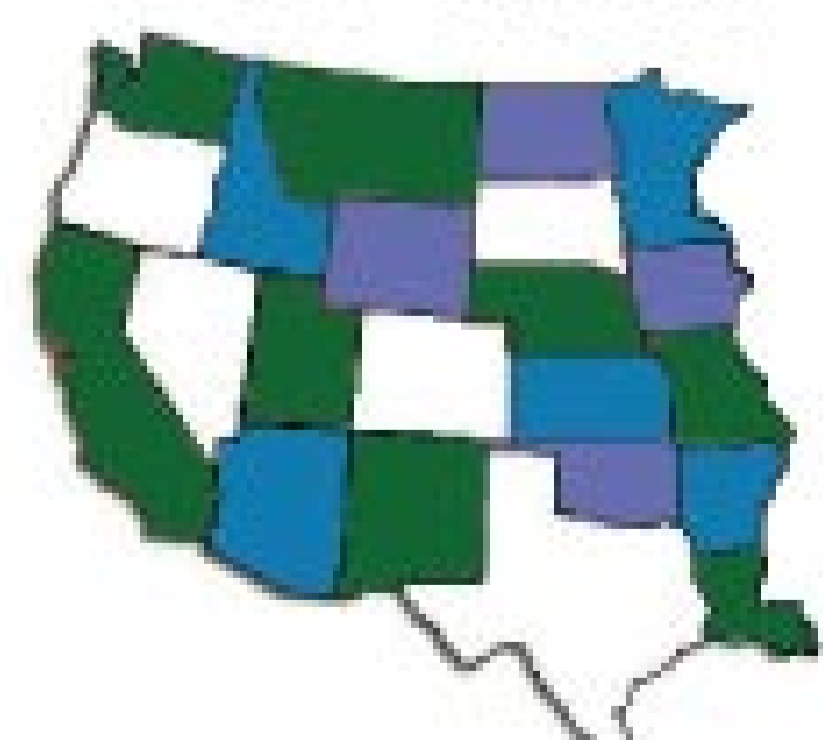

West Coast  
303-325-3186

# THE SLIDE IN WAREHOUSE

Your Single 'Coast to Coast' Supplier For Vacuum Slide In Units



East Coast  
814-933-1208

# The 'S' Has It

When it's time to incorporate, the S corporation offers a number of advantages — and raises a few caution flags, too

By Erik Gunn

It's not an uncommon occurrence. A man or woman with a great business idea decides to take the plunge. At first it's an evenings-and-weekends thing. But as time goes by, it becomes more profitable, and more time-consuming. Pretty soon, the entrepreneur realizes it's time to quit the day job.

And because it's been a one-person show, it's very possible that the founder has never bothered to incorporate. That can be a big mistake. It might seem easy just to keep going as a sole proprietor, but for the long-term security of your business, that can be a risky strategy.

"For most small businesses, especially of the type that has income, assets of any size and the need to designate a single person as president for contact with the public, a corporation is really the best," says Richard Latta, a lawyer with the firm Michael Best & Friedrich in Madison, Wis. That's especially true for a business that works in a field that requires a license, is governed by state or federal regulations, or will expose the owner to liability if things go wrong.

Incorporating limits the owner's legal exposure to the assets of the corporation. It also offers new sources of financing.

A sole proprietor who needs to raise funds has no choice but to borrow money and pay it back with interest. But a corporation can raise capital for expansion and other purposes by selling shares. (Of course, that's a complex legal process to be undertaken only with professional consultation and following rules and regulations — but it does expand your fundraising options.)

Additionally, the simple act of incorporating can make your business look more serious and improve your creditworthiness to banks you approach for traditional financing.

## C, S, or LLC?

There are three basic types of corporations. C corporations are the ones we most commonly think of — typically major corporations like General Electric or Exxon. While there may be specific reasons to opt for that structure, small businesses generally don't.

Instead, they typically become either S corporations or LLCs — limited liability companies. Why? One big reason is that C corporation income is taxed twice: once at the corporate level, and again as personal income when it's paid to the owner. Income from an S corporation or LLC is only taxed once, at the personal owner/shareholder level, Latta says.

Another advantage to the S corporation or LLC is in how often you have to pay taxes. C corporations typically pay estimated federal income taxes (and state taxes, if they apply) every month. Many LLCs and S corporations, like most unincorporated sole proprietors, pay those taxes every quarter.

Deciding between an S and an LLC is a little more complicated. S corporations have been around a long time; LLCs are relatively new. For the most part, they're pretty similar, but there are important differences.

The law limits the number of S corporation shareholders to no more than 100 (with limited exceptions for families), and no foreigners, Latta notes. Also, S corporation shares cannot be held by an Individual Retirement Account, says Tom Ochenschlager, retired vice president of taxation for the American Institute of Certified Public Accountants. Violating any of those or some other rules can lead to disqualification of an S corporation.

However, there may be some uncertainties about how much an LLC actually protects the liability of an individual, Latta says. While S corporations have firmly withstood attempts to "pierce the corporate veil" between the

Erik Gunn is a business writer in Racine, Wis. Readers may direct inquiries to him by contacting this publication at 800/257-7222 or e-mailing [editor@pumper.com](mailto:editor@pumper.com).



Incorporation of any kind will cost you something — in money and in compliance with the laws of your state and the federal government as they apply to your chosen corporate structure. But the benefits far outweigh any costs in the protection it offers you.

corporation and the shareholder's personal assets, there are some states in which the strength of the LLC shield "hasn't been thoroughly tested," he says.

For that reason, Latta believes the S corporation offers just a bit more security. But that may differ from state to state, so you should always check with knowledgeable financial and legal advisors before taking any steps to incorporate or change your existing corporate structure.

## A CAUTION ABOUT PAY — AND TAXES

There's another point about LLCs or S corporations that you may hear about from some advisors. But it requires great caution. Corporations pay out two kinds of income to shareholders. Shareholders who are also officers or employees may get paid in wages or salary. But shareholders also can get paid in the form of dividends.

In the case of S corporations or LLCs, both kinds of income get assessed federal income taxes (and state and local taxes as well, if they apply). Wages and salary, however, are also subject to payroll taxes for Medicare and Social Security (FICA).

Thus, it's possible for some of your corporate earnings to come to you as wage or salary income, and other earnings, with a lower tax bite as a consequence, as dividends. But if you apply this strategy, you should do it only with the most expert professional advice.

"It is a hot button with the Internal Revenue Service," Ochenschlager says. One key test is how much money you've invested up front in the business. A dividend, after all, is only to be paid as a return on investment. If your business hasn't required much in up-front cash out of your own pocket for supplies, inventory or equipment, the taxman is likely to be very skeptical of your attempt to claim a dividend.

Also sure to raise eyebrows at the IRS are artificially low salaries for shareholder-employees who could earn much more for their work out in the job market, and other income claimed as a "dividend."

"If it turns out you're working a 40-hour week and only paying yourself \$5,000, the IRS will come back and say that's not right," Ochenschlager says. "You should be paying yourself a salary equivalent to what you'd pay someone else to do that same job."

## THE BOTTOM LINE

Incorporation of any kind will cost you something — in money and in compliance with the laws of your state and the federal government as they apply to your chosen corporate structure. But the benefits far outweigh any costs in the protection it offers you, experts say.

When you do incorporate, the S corporation is probably your best bet, at least for now. But make sure you understand all the rules that apply to that structure, and follow them strictly. Because the whole reason you're doing this is for a smoother-running business and peace of mind. And that's real corporate power. ■

# GapVax®

Toll-free US/Canada  
**888-442-7829**  
**www.gapvax.com**

**Manufacturing the best vacuum equipment  
on the market since 1989**

**Industrial Vacuum Loaders**

**Combination JetVacs**

**Hydro-Excavators**

**Skid-mounted Vacuum Systems**

**WetVacs**

**Cyclone Trailers**

**Stand-alone Baghouses**

**High Dump option now available  
on our Industrial Vac Loader  
AND our Hydro-Excavator**

**A Complete line of Parts &  
Accessories**

**Easiest & Safest to Operate,  
Lowest Maintenance Costs, Best  
Fuel Efficiency, CUSTOM built,  
Reliable and Versatile, Superior  
Service, Top quality components  
and more!**

**Oct. 19 & 20  
Clean Gulf Expo  
Tampa, Florida  
Oct. 27-29  
NAI Coatings Show  
Indianapolis, IN**



**GapVax® PartsExpress  
gives you all the parts  
and accessories you need  
for any task! Check out  
the parts catalog on our  
website!**

# 450 Gallon Slide-In Tank

300 Waste / 150 Fresh

- Self-Contained • Skid Mounted • Lightweight Aluminum
- Easily Maneuvered • Fits Standard Pick-Up

**Introductory Priced At...**

## \$7,995

**...Ask about FREE SHIPPING!**

Contact Phil Hodes

## 888-281-9965

[www.tristatetank.com](http://www.tristatetank.com)

Fax: 913-279-3151  
phodes@tristatetank.com

Electric Start 5.5 HP Honda Conde Super 6 vacuum pump w/ 4-way valve

12 V washdown with 50' hose

30' of 2" fill hose

3" Discharge

12 Volt battery



*progress tank*



**Take Delivery In Daytona!**

See the *progress tank* Slide-In Unit & the Ford 450 Restroom Tank Truck at the PSAI Annual Convention Nov. 9-13th, Daytona Beach, FL.

**Drive One Home!**

Advertised Prices good through 11/15/10



**1200 Gallon Restroom Service**

Masport HXL4 vacuum pump system, 4 way valve, washdown system, remote PTO, toilet carrier and storage cabinet.

**2011 Ford 550** 19,500 GVW  
300 HP, auto.trans., XL trim.

## \$62,225

Subject to prior sale.



## T&T Tools, Inc.

Fax: 800.521.3260

Email: [sales@tandttools.com](mailto:sales@tandttools.com)

## 800.521.6893

[www.MightyProbe.com](http://www.MightyProbe.com)

Call for a FREE Catalog



Call for a FREE Catalog

### HOOKS...

- > Several different styles of heat-treated hooks are available
- > Top Poppers are great to open manhole covers
- > The Handy Hooks allow two handed use

### PROBES...

- > Insulated, standard, and specialty soil probes
- > Metal shaft sizes: 3/8" round, 3/8" hex, or 7/16" hex
- > Replaceable tips are threaded on and hardened
- > A "slide" allows the handle to pound the shaft into the ground

THE  
NEWLY  
DESIGNED

# TUFWAY®

## MORE ATTRACTIVE, LESS MAINTENANCE AND A NEW FOOT FLUSH OPTION!

A newly designed door and molded in vents are two upgrades you can't miss on the new Tufway. Improved styling gives it more curb appeal and the new vents will lower yearly maintenance costs to almost nothing.

After we finished restyling the Tufway we thought we were done making improvements. That's when a customer asked for a Tufway with recirculating foot flush. We knew we had one more job to do.

Guess what? You now have the option of getting a Tufway with a powerful recirculating foot flush system.

From great looks to more options, the new Tufway is ready for the next generation.



*Watch A Video  
Of The Recirculating  
Foot Flushing Action  
Online*



### FOOT FLUSH OPTION

*One press of the pedal  
will convince you that  
this system has the  
power to clean itself  
after each use.*



800-328-3332  
www.satelliteindustries.com

**TOICO**  
INDUSTRIES

"YOUR ONE STOP SOURCE"

**1-888-935-1133**  
[www.toico.com](http://www.toico.com)

YOUR ONE STOP SOURCE FOR PORTABLE RESTROOM PARTS AND SUPPLIES

**SmithCo**  
SIDE-DUMP TRAILERS

# SIDE DUMP

Call **800-779-8099**  
[www.sidedump.com](http://www.sidedump.com)

30902 C38  
Le Mars, Iowa 51031

**CP-20 Offroad**

**SHV Series**

**DT Series**

**MHV Series**

**S Series**

*Manure, Slurry, Sludge, Green Waste, Food Residuals, Compost, SmithCo Hauls it All.  
Stock Pile, Spread, Stability, Selection, Service...SmithCo*



# Save money with these pre-2010 emission trucks.

NEW AND PRE-OWNED SALES | RENTAL | LEASING | PARTS | SERVICE | BODY SHOP | FINANCING



**2011 Peterbilt Models 365 and 388 with 110 - 120 BBL 4700-5000 Gallon Water Trucks – 16 in production.**

New triaxle, CAT C13 470HP, Fuller RT016908LL, Peterbilt Air Trac suspension. Pik Rite 110BBL 4700 gal steel vacuum tank, Jurop LC420 liquid cooled pump. Aluminum hose trays. Options can be added before delivery. **Call for pricing.**



## **Peterbilt 340 Standard 3600 Gallon Vacuum Trucks**

Automatics and standards in stock. Non-code 3600 gallon Pik-Rite tank. Masport HXL400WV liquid cooled pump, aluminum hose trays, internal primary to secondary piping for clean mount. 10 yr tank warranty standard. Options can be added before delivery. **Call for pricing.**



## **2011 Peterbilt 348 with 4000 Gallon Aluminum Vacuum Tank**

Automatic or standard transmission. Pik Rite 4000 gallon aluminum tank. Jurop LC420 liquid cooled pump. Aluminum hose trays. Options can be added before delivery. Two stage engine brake included. **Call for pricing.**

# 877-661-4511

**Refuse Sales Team:** Gregg Wilkinson | Jason Guzauskas | Jesse Fullilove | Ryan Johle  
refusesales@rush-enterprises.com | 8810 IH-10 East | San Antonio, TX 78219

# Refuse Systems



www.rushrefusesystems.com



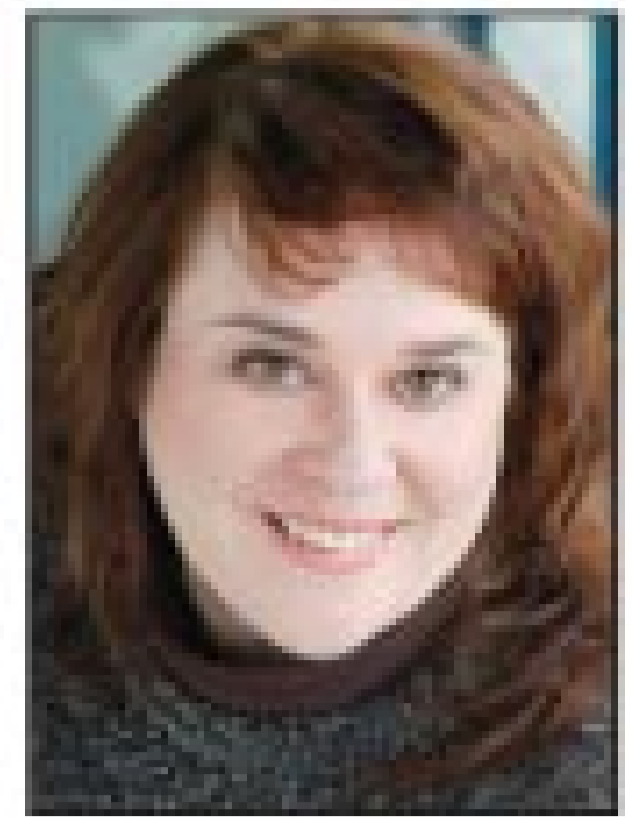

# Blocking Your Path to Profitability

Land application restrictions, low-ball competition and lax inspection and pumping regulations are among threats to business building

By Mary Shafer

Everybody has an opinion on the state of the industry, and much of the talk revolves around issues that get in the way of profitability, expansion and an operator's ability to make decisions without having his hands tied at every turn. Our readers are no different, and here they discuss several obstacles threatening their ability to make a living as septic service contractors.

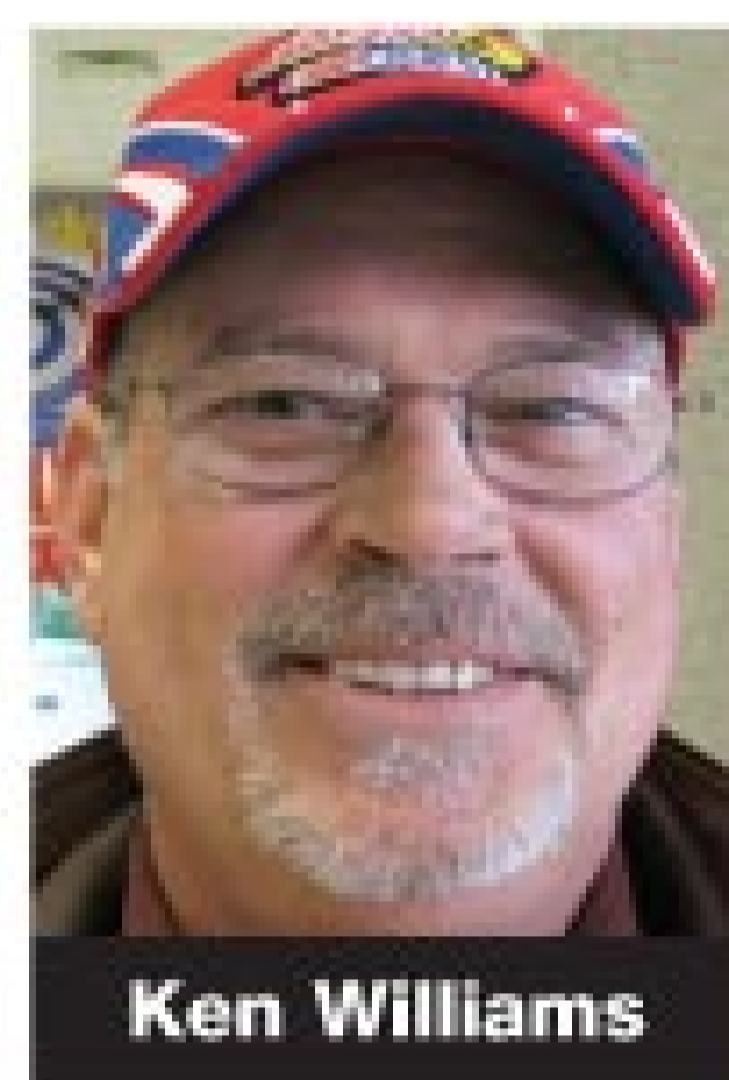

Name: **Ken Williams**  
Company: **Certified Septic Service**  
Location: **Knoxville, Iowa**  
Employees: **1**  
Years in Business: **2**

"In Iowa, the only thing is the restrictions on land application," says Ken Williams of a threat he feels to his business. Certified Septic Service does septic pumping, inspections, maintenance and testing, but Williams' concern is about the future of disposal.

"We're being forced to go to a public treatment plant, and it adds a lot to the cost of our job. And a lot of them won't even accept the septage. Many of the public plants can't even handle their own city's waste, let alone take on the county stuff."

He says he has no plans to enter the dewatering business himself any time soon. But a pumper within 50 miles does it and Williams will likely be hauling his septage there before too long. "That's probably the direction we're all going to be heading," he says, guessing that he'll have to start doing so within maybe 2-3 years, as tougher land-application regulations move out from the more urban areas where they originated.

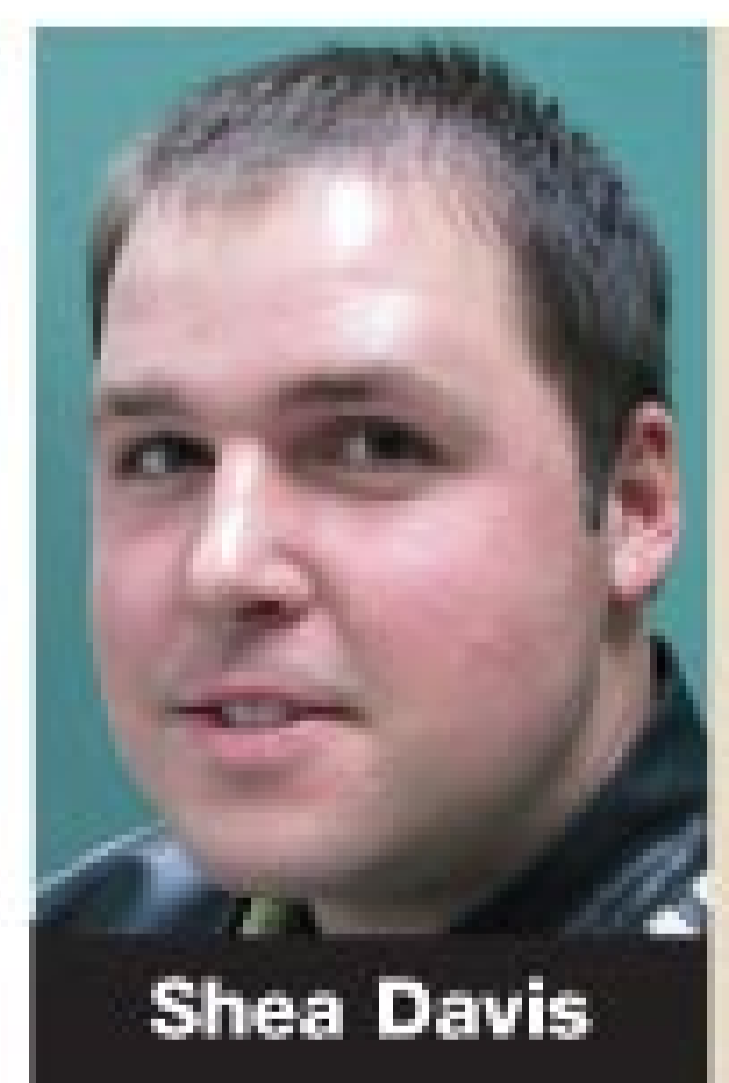

Name: **Shea Davis**  
Company: **Running D Construction**  
Location: **Amarillo, Texas**  
Employees: **5**  
Years in Business: **12**

Shea Davis feels less-stringent regulation of septic system installations is limiting his profitability. He would like to see state legislation requiring inspection and maintenance of all types of new septic systems, something that would be good for the environment and for a healthy business for pumping contractors.

"We're being forced to go to a public treatment plant, and it adds a lot to the cost of our job. And a lot of them won't even accept the septage. Many of the public plants can't even handle their own city's waste, let alone take on the county stuff."

Ken Williams

"I think that when you pull a septic installation permit, it should be mandatory that (the customer) have the system pumped every 3-5 years. Just like with aerobic systems; those come with a maintenance contract. So when you put in your standard septic system, it ought to be mandatory that it be taken care of, just like the aerobic ones."

He says all systems should be treated equally, with whatever level of regular maintenance required to keep the system healthy.

"To my knowledge, there's no such law in Texas, and that's a very neglected aspect of our industry. If someone would put such a law into practice, that systems be pumped every so often, it would save homeowners countless dollars" in the long run, he believes. And it would build more consistent revenue streams for businesses like his



Name: **Andy Coleman and Mike Norcross**  
Company: **Wastewater Services Inc.**  
Location: **Ellington, Conn.**  
Employees: **5**  
Years in Business: **5**

Wastewater Services Inc. supervisor Mike Norcross echoes the concern over rising disposal costs at public treatment facilities. "I'd say the prices for offloading keep going up, and it's hard to match those rises with continuing price increases to customers," he says.

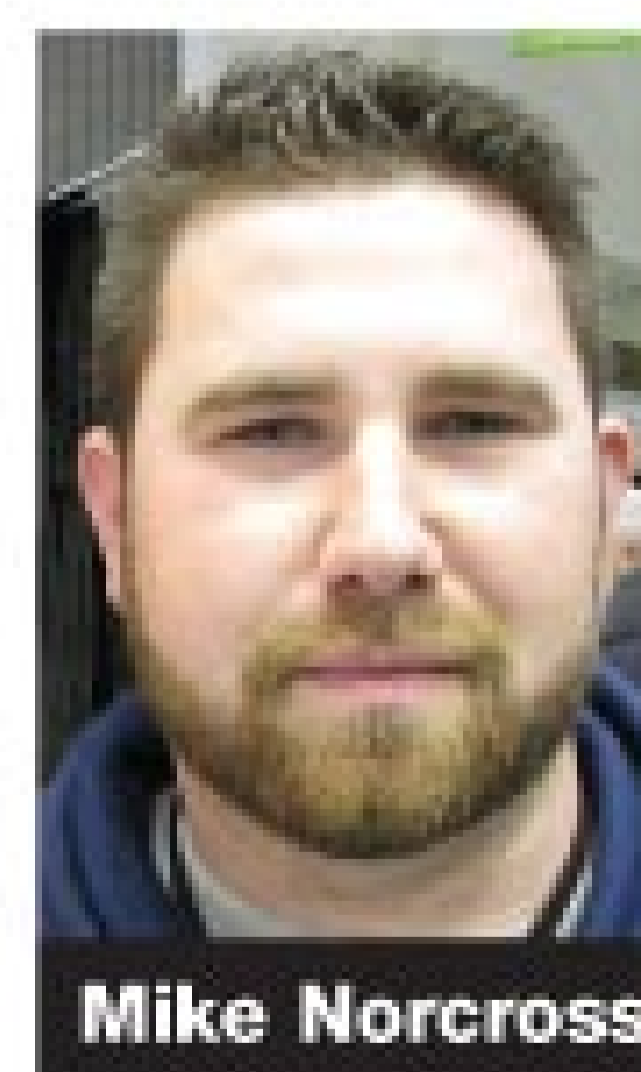

He reports increases of \$30 per 1,000 gallons, which pushes the disposal costs for customers up to \$120. "Also, when fuel skyrocketed, that was hard to cover with a surcharge. And there's always the downward pressure on (service charges) when other guys are out there scrambling for work and pumping more cheaply than ever."

His boss, Andy Coleman, says falling prices due to the recession have eaten into profits on the inspection side of the business, but he fights that with a message about the quality of service he provides. "I feel we do the best job because we use the video, so we do a higher quality inspection instead of just flow tests or something less revealing. When customers call, we explain exactly what we do and let the service sell itself." ■

Everyone's talking about it.

Find out why.  
Get your **FREE** subscription today.

**ONSITE**  
**installer**

PROMOTING WASTEWATER TREATMENT  
QUALITY AND PROFESSIONAL EXCELLENCE

Visit [www.onsiteinstaller.com](http://www.onsiteinstaller.com) or call 800-257-7222.

# HOW DO YOU LIKE YOUR SAVINGS? WET OR DRY?



## SAVE \$\$\$\$\$ ON DEODORIZERS IN EXCLUSIVE FRAGRANCES

Our Fragrance of the Month discount deodorizer program offers you a choice – either BlueWorks, our most powerful liquid deodorizer; or DriPax, our new water soluble, portion-controlled product. It's your choice and the savings are BIG! Just call **Cindy** at **(800)241-7951** or your PolyPortables division manager for details.

All purchases from Green Way Products qualify for Blue Bucks. Like money in your pocket, Blue Bucks spend like cash on PolyPortables or Green Way Products.

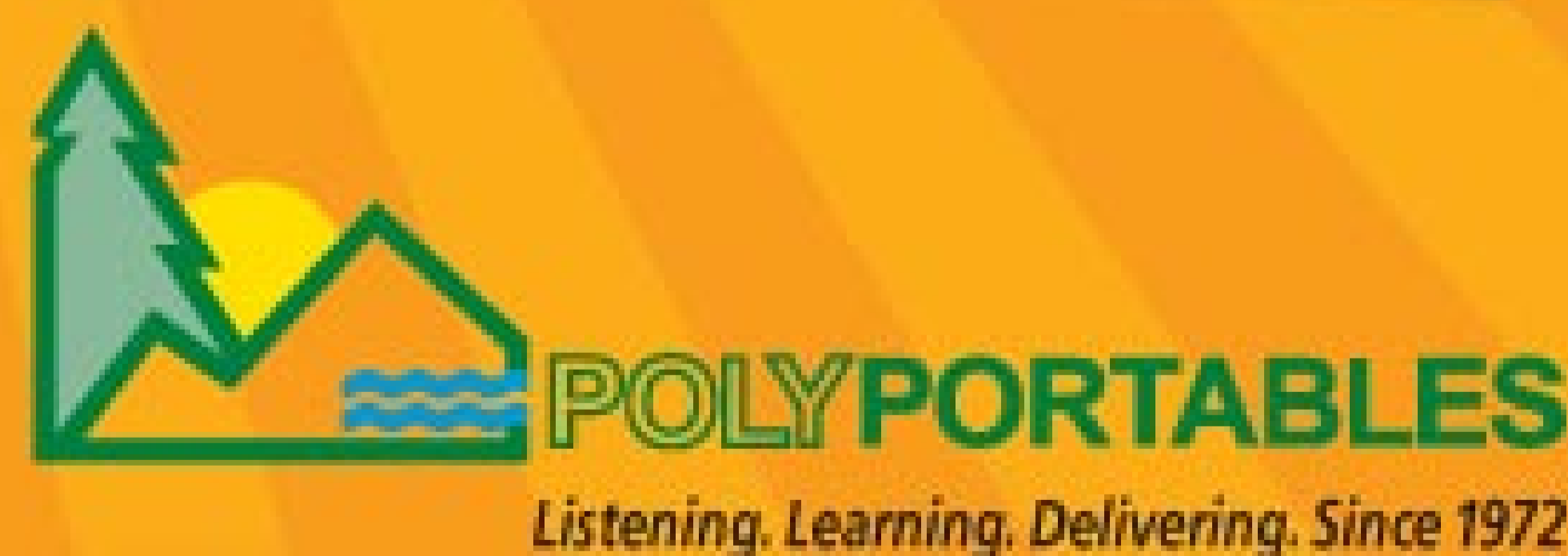

99 Crafton Drive, Dahlonega, GA 30533 USA • Phone (800) 241-7951 or (706) 864-3776 • Fax (706) 864-8111 • [www.polyportables.com](http://www.polyportables.com)

Only PolyPortables offers high-performance Green Way Products

TOILET DEODORIZERS • TOILET CLEANERS • AIR FRESHENERS

All Green Way deodorizers, cleaners and air fresheners are earth-friendly, people-friendly products. They are developed and manufactured in our facilities in Dahlonega, Georgia by Green Way Products, a PolyPortables sister company.



# Powerful. Performance.

*Superior  
Design!*

## Defender 500 By Challenger

### Commercial Duty Vacuum Pump

Ballast Port Cooling for Extended Use in Severe Conditions

- One Piece Shaft Design
- Heat Resistant Viton Seals
- Remote Oil Tank
- 4 Port Oil Pump for Controlled Delivery
- Oiled Bearings, Front & Back
- Built and Supported in the USA

Visit our website for information on the Defender 500 and our complete product line.

# NVE

National Vacuum Equipment *Home Of The Challenger*

800.253.5500 | [www.natvac.com](http://www.natvac.com)



## What Lies AHEAD?

If weather is less than perfect this season, JAG Mobile Solutions is ready for the worst Mother Nature has to offer. With a full inventory of **IN STOCK** shower and restroom trailers, we're prepared for anything. **Are you?**

Call now for more information on JAG's available mobile showers, restrooms and disaster relief equipment.

**24 Hour Service -**  
JAG President 304-210-5999 OR JAG Director of Sales 704-287-2065

# 800-815-2557

[www.jagmobilesolutions.com](http://www.jagmobilesolutions.com)

## Pump! Save! Earn!

With **PRO-PUMP**

The Finest Name in Biological Products for Septic Systems, System Recovery, Odor Elimination and More...



- Septic System Treatment
- Absorption System Recovery
- Aerobic System Treatment
- Drain & Grease Traps
- Solids Reduction
- Odor Control
- Bio-remediation

**Our 33rd Year!**

**Call Greg Toll Free at 1-800-326-7867 and ask about our Special Discounts & Free Freight!**

*Solving Problems, Naturally!*

**Ecological Laboratories INC.**

TOLL FREE: 1-800-326-7867 • FAX: 516-823-3440 • EMAIL: [info@propump.com](mailto:info@propump.com)

Visit our web site at: [www.propump.com](http://www.propump.com)



# IMPERIAL INDUSTRIES INCORPORATED

THE PROUD TRADITION CONTINUES...

For Tank Information Contact - Jim Stieber | jim@imperialind.com or Randy Tischendorf | randy@imperialind.com



HEATED VALVES

CLEANERS CADDIE

## VACUUM TANKS

DESIGNED AND MANUFACTURED BY IMPERIAL, IND  
STEEL - ALUMINUM - STAINLESS



PORTABLE TOILETS  
PORTABLE WASH SINKS  
SANITIZER STATIONS

### IN STOCK!

2011 DODGE AND FORD 1175 GAL. ALUMINUM  
PORTABLE SERVICE UNITS  
CALL FOR PRICING

### NEW!

1000 GAL ALUMINUM  
FORD F450  
CALL FOR PRICING



THANK YOU FOR YOUR ORDER  
ASAP PUMPING SERVICES  
2011 INTERNATIONAL  
4500 GALLON CARBON STEEL WITH  
ALUMINUM HOSE TRAYS



THANK YOU FOR YOUR ORDER  
CENTRAL SEPTIC SERVICES  
2011 INTERNATIONAL  
5000 GALLON CARBON STEEL



1175 ALUMINUM  
PORTABLE TOILET SERVICE UNIT  
2011 FORD 550 AUTOMATIC

## STOCK OR CUSTOM SLIDE-INS IMPERIAL COVERS IT ALL



100 GALLON

250 GALLON

450 GALLON

SELF-CONTAINED SLIDE-IN UNITS  
"THE ORIGINAL"  
OFTEN COPIED - NEVER DUPLICATED



Ford/Dodge Dealer  
Mark King  
800-722-7382  
mking@vhautos.com



International Dealer  
Allen Luebbe  
800-236-2044  
allen@midstatetruck.com



## Tank Troubles?

### Concrete septic tank construction practices are the key to avoiding hydrogen sulfide deterioration

By Roger E. Machmeier

**Q** Why do concrete risers, distribution boxes and lids deteriorate? I'm guessing it's due to detergents, etc., but what are the ones homeowners should avoid? It is stuff like this that makes me love the plastic distribution boxes and risers. I'm not sure about water softeners either, as far as concrete deterioration goes. I have heard that water softeners raise the salinity of the effluent causing the sludge in the tank to sit lighter and fluffier.

**Does using a garbage disposer or any other means of getting excess food to the septic tank raise the hydrogen sulfide level?**

**A** There are two basic reasons concrete tanks and other concrete structures deteriorate: one is hydrogen sulfide gas, and the other is poor concrete construction of septic tanks and accessory parts like the manhole riser, drop boxes, etc.

Where does the hydrogen sulfide gas come from? This gas, which has the smell of rotten eggs, is a byproduct of anaerobic digestion of organic wastes flushed into the septic tank. The chemical symbol for hydrogen sulfide gas is H<sub>2</sub>S. When H<sub>2</sub>S combines with H<sub>2</sub>O water vapor, a chemical substance, H<sub>2</sub>SO<sub>4</sub>, is formed. You may recognize this formula as sulfuric acid.

What is so bad about sulfuric acid? Well, it just loves to break down porous concrete. And that's what happens in your concrete distribution boxes (you should be using drop boxes),

The National Precast Concrete Association and the National Onsite Wastewater Recycling Association have produced a manual and video of best practices for the production of high-quality precast concrete septic tanks. For more information, contact NPCA at 800/366-7731 or go to [www.precast.org](http://www.precast.org).

the manhole extensions of the concrete septic tank, and the portion of the septic tank above the liquid level. The concrete below the liquid level in the septic tank won't have any sulfuric acid in contact.

The H<sub>2</sub>S gas can also move into other concrete structures of the septic system, like the distribution box, manhole extension, etc. When it combines with H<sub>2</sub>O water vapor, the sulfuric acid does its job on any porous concrete.

#### START WITH THE RIGHT CEMENT

Why is the concrete porous? The basic reason is the proper curing procedures and the proper cement have not been used. Sulphate-resistant cement must be used in the mix and the concrete must be properly cured. The same cement and curing procedures must be used for the concrete accessories, such as the septic tank cover, manhole extensions, drop boxes, etc.

I have observed tank manufacturers who used the proper cement and curing procedure for the septic tank, but did not use the same curing for the accessories. To speed up the process so the form could be removed sooner, the cement mixture was drier, and the concrete in the accessory was not cured properly. The tanks from this manufacturer would not deteriorate, but the smaller concrete parts would be subject to deterioration by H<sub>2</sub>S gas. You should consider using heavy-duty polyurethane products for these parts of the septic system.

National standards exist for the manufacture of concrete septic tanks, one of which is ASTM C1227, Standard Specifications for Precast Concrete Septic Tanks, as well as those created by IBCO Evaluation Service Inc. and the International Association of Plumbing and Mechanical Officials (IAPMO).

The National Precast Concrete Association has had many years of active involvement with ASTM to produce Standard C1227. This standard addresses specifications for septic tank volume, the number of com-

*Roger Machmeier, Ph.D., P.E., retired as a professor and Extension Agricultural Engineer for the University of Minnesota and is a past recipient of the pumping industry's Ralph Macchio Lifetime Achievement Award. He answers reader questions regarding septic system operation and maintenance. Contact Machmeier through COLE Publishing by e-mail at [editor@pumper.com](mailto:editor@pumper.com), by fax at 715/546-3786; or by mail at P.O. Box 220, Three Lakes, Wis. 54562.*



partments, liquid surface area, access openings for cleaning and inspection, inlets, outlets, baffling devices, and baffle submergence.

NPCA and the National Onsite Wastewater Recycling Association have produced a manual and video of best practices using these standards for the production of high-quality precast concrete septic tanks. For more information, contact NPCA at 800/366-7731 or go to [www.precast.org](http://www.precast.org).

#### DETERGENTS NOT AN ISSUE

H<sub>2</sub>S is formed when the aerobic bacteria in the septic tank do their thing on organic matter, such as human waste and the waste food from a garbage disposer. The more food for the bacteria, the more H<sub>2</sub>S will be generated. So, you are correct about the use of garbage disposers. These are not recommended with a septic system because of overloading of organic matter. Not only is more H<sub>2</sub>S generated, the sludge layer builds up faster.

I don't have information to indicate detergents are responsible for more H<sub>2</sub>S. I don't believe a detergent will break down even porous concrete.

In regard to water conditioners and salt, a water conditioner operating properly will not send much sodium chloride to the septic tank. Actually, a little salt is of benefit to bacterial action. Too much salt will slow down the bacterial action.

If the homeowner does not properly maintain the water conditioner, and iron is allowed to coat the resin beads, excess salt will be discharged to the septic tank each time the conditioner recycles.

However, my opinion is that a concrete septic tank made according to NPCA specifications will not be affected by the salt from even a poorly maintained water conditioner.

Hydrogen sulfide gas is going to be generated in every active septic tank. Sulfuric acid will be present above the liquid level of every septic tank. Unless the concrete septic tank and its accessories are properly made, they will deteriorate after time. ■



Portable Sanitation Products

# Extreme Odor Eliminators



## J&J's New Manufacturing Facility!



### J&J Chemical Co.

J&J East - Colbert, GA • J&J West - Moab, UT • 706-546-7069 • fax 706-546-7178

1-800-345-3303 • [www.jjchem.com](http://www.jjchem.com) • [info@jjchem.com](mailto:info@jjchem.com)

For 30 years, V.E. Enterprises has been building liquid storage trailers and tanks for leading environmental, waste management, construction and energy service companies for a reason: customers value **experience**.

Experience alone isn't enough to stay competitive in this global economy. It takes a world-class facility, state of the art equipment and ASME certified welders to manufacturer products that are the highest **quality**.

Maintaining top quality doesn't always guarantee customers will keep coming back. It takes a company that stands with its customers - listening, thinking and responding with the next breakthrough storage design - that's **innovation**. That's V.E. Enterprises.



**experience • quality • innovation**

*Setting the Standard For Liquid Storage and Transports Since 1987*

800.234.2329  
[sales@veenterprises.com](mailto:sales@veenterprises.com)  
[www.veenterprises.com](http://www.veenterprises.com)

**VE**  
**ENTERPRISES, INC.**

**HOUSE OF IMPORTS**

[WWW.HOUSE-OF-IMPORTS.COM](http://WWW.HOUSE-OF-IMPORTS.COM)

CALL ANGEL AT:

**786.258.3384**

OR **305.691.4778**

▶▶ SINCE 1947

**TRUCK SALES**

IN BUSINESS FOR 60 YEARS!



**2000 MACK CH-600**

AC, Jake Brake, 460 HP, 10 speed, Factory Double Frame, Low miles, New 4,000 GAL. Tank. 420 Liquid Cool CFM Jurup Pump. In Progress! - \$69,900



**2005 PETERBILT 379**

CAT C-15, 475 HP, 10 speed, New 5,000 GAL. Tank, Double Frame, 3rd axle, Jake Brake, 500 CFM PUMP, 100,000 Mile Warranty. In Progress! - \$96,000

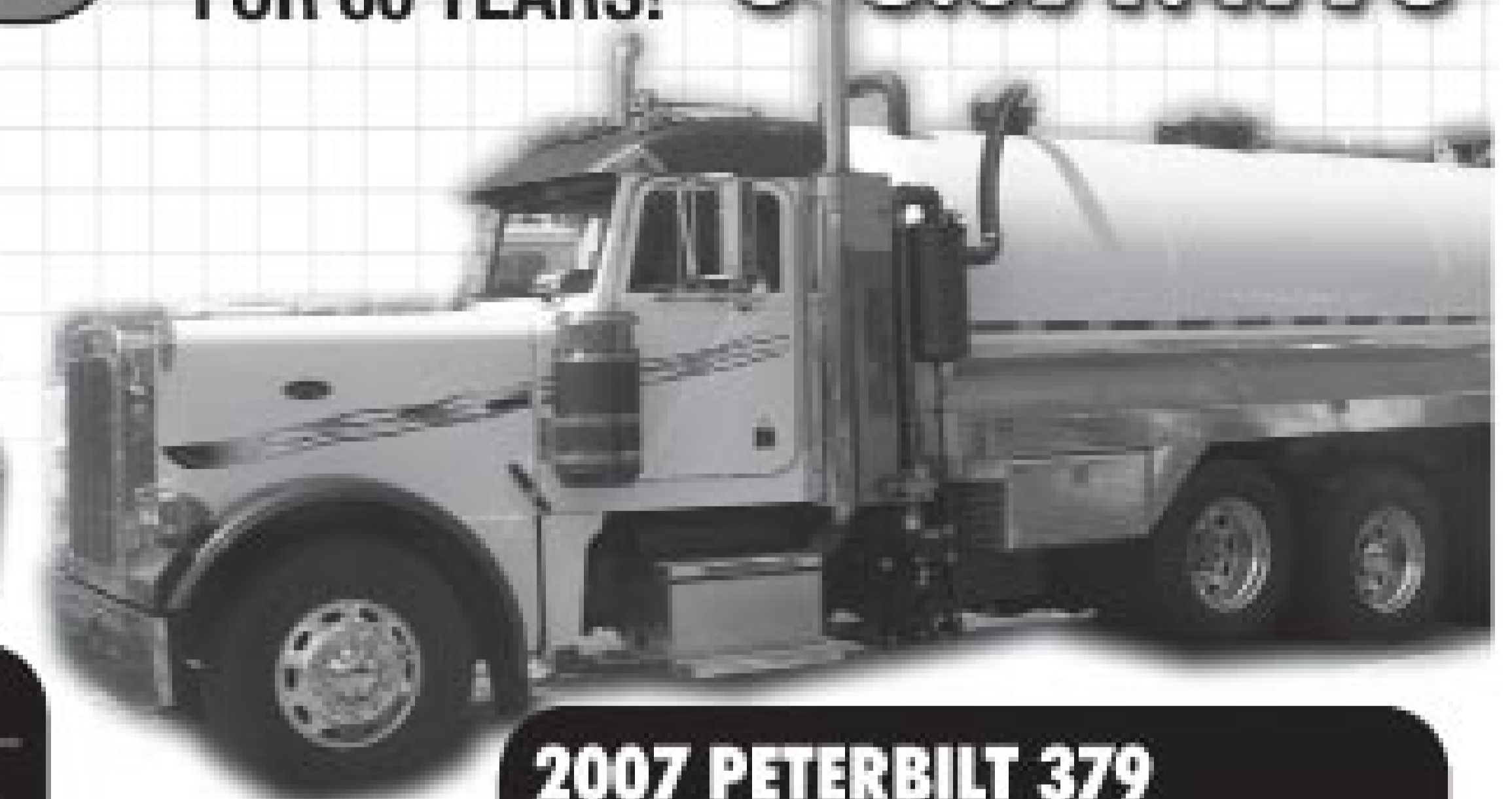

**2007 PETERBILT 379**

Pre-Emission, AC, Jake Brake, Cummings ISX, 450 HP, 10 Speed, LOW MILES, Cruise Control, New 3rd Axle, New 5,000 Gal. tank, 500 CFM Pump 100,000 Mile Warranty - \$109,000

**2005 INTERNATIONAL 4200**

100K Original Miles, Automatic, AC, 200 HP, New 2,000 GAL. Tank, 250 CFM Jurup Pump...In Progress - \$58,500

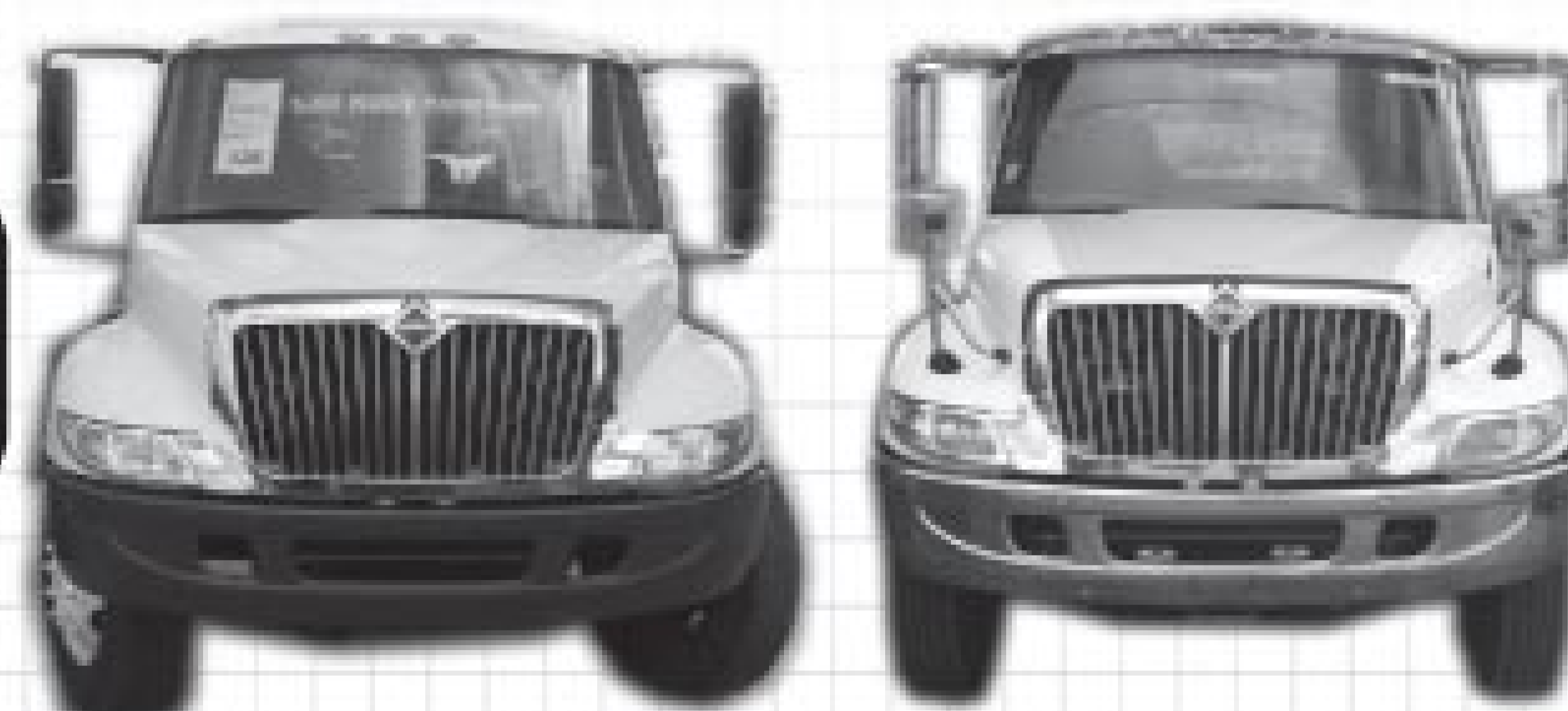

**2003 INTERNATIONAL 4400**

275 HP Turbo Diesel, Automatic, AC, 274K Miles, New 2,500 GAL. Tank, 250 CFM Jurup Pump, In Progress - \$53,500

Angel Dominguez - 786-258-3384

Gino Dominguez - 786-271-7112

▶ DELIVERY ▶ EXPORT ▶ PUMP WARRANTY: 1 YEAR ▶ TANK WARRANTY: 5 YEARS

**100,000 MILE LIMITED FACTORY WARRANTY**





51 YEARS OF DEPENDABILITY

# TUFF-JON

- One-Piece Construction
- Lightweight
- Rust-Free Hardware
- Wood and Poly Skids
- Large Variety of Colors



Tuff-Jon III



Tuff-Jon



Tanks in 60, 105, 225, 300 and 440 Gallon Sizes



TJ Junior Single Free Standing Sink (20 gallons fresh water)

90 Gallon Free-Standing Sink (45 gallons fresh water)



Interior View of TJ-III with sink

### — OPTIONAL ACCESSORIES —

- Lifting Bracket Assembly
- Sky Heater
- Sinks Available For Both Styles of Tuff-Jon



60 Gallon Rinse Tank



TJ Handy Stand Waterless Gel Touch Dispensers

**The TSF Company Inc.** | 2930 S St. Phillips Rd. | Evansville, IN 47712

Toll Free: **1-800-843-9286** | **812-985-2630** | Fax: **812-985-3671**

E-mail: **tsftuffjon@sbcglobal.net** | Web Site: **www.tuff-jon.com**



PORTABLE TOILETS / HOLDING TANKS / HAND WASH UNITS / ACCESSORIES



**Atlanta Rubber & Hydraulics**  
because you deserve more

*Look no further, for the highest quality products at the most competitive price*

**We offer a vast selection of Pumper & Cleaner products to meet your specific needs.**

- Kanaflex® Hose
- Quick Coupling Adapters
- Brass Valves
- Jetting and Sewer Hose
- Safety Products
- Gloves, Rain Suits, Boots, And more



**Value Adding Services:**

- Special Packaging
- Custom Assembly Work
- Fabrication
- On-Site Troubleshooting

Our customers are our main priority. We believe in **honesty, integrity and fairness** and apply those principles across every aspect of our business. The result is a level of customer service you won't find anywhere else. Discover for yourself what sets Atlanta Rubber & Hydraulics apart from the competition.

## OCTOBER SPECIAL

3" x 25' Green Black Septic Suction Hose -  
**ONLY \$87.50**  
(Coupled M X F Aluminum Quick Couplings)

1640 D Sands Place Marietta, GA 30067  
Toll Free: 800-282-6272 PH: 770-955-5225  
FX: 770-955-2377 Email: sales@atlantarubber.com  
[www.AtlantaRubber.com](http://www.AtlantaRubber.com)



Filter Box Interior

Draining Down



# Aqua-Zyme Disposal Systems

*"From the Grease Trap to the Garden"*  
- Dewatering & Composting -

## The ADS Dewatering System

is built by a pumping company for pumpers. You are welcome to come and watch the 30 yard box dewater 20,000 gallons of grease trap waste and/or septic tank waste in only 2 hours!

By using the ADS dewatering system along with our Compost Facility, we have turned our disposal costs into a profitable venture!

**#1 Box on the market!**

**Call 979-245-5656 for Info!**  
**\$ Financing Available \$**

P.O. Box 489, Van Vleck, TX 77482 • [www.aqua-zyme.com](http://www.aqua-zyme.com)  
1-979-245-5656 • [zymme@aqua-zyme.com](mailto:zymme@aqua-zyme.com) • U.S. Patent # 6,364,122



# Discover a world of solutions.

And open a new universe of opportunity.

Four brands. One total solution. That's the advantage of Federal Signal Environmental Solutions Group. Because you can rely on one industry-wide partner to help broaden the scope of your business, maximize efficiency, and make more money. From unmatched product innovation to world-class training and refurbishment, you'll find the solutions you need from the brands you can trust.



**VACTOR**  
Subsidiary of Federal Signal Corporation

[www.vactor.com](http://www.vactor.com)  
815.672.3171



**GUZZLER**  
Subsidiary of Federal Signal Corporation

[www.guzzler.com](http://www.guzzler.com)  
815.672.3171



**Jetstream**  
Subsidiary of Federal Signal Corporation

[www.waterblast.com](http://www.waterblast.com)  
800.231.8192



**SOLUTIONS**  
TRAINING • RENTALS • PARTS • SERVICE

[www.fssolutionsgroup.com](http://www.fssolutionsgroup.com)  
800.822.8785

 **FEDERAL SIGNAL**  
Environmental Solutions

# Classy Truck of the Month



## MUMFORD SERVICES

### North Kingstown, R.I.

**T**his white and red heavy-hauler 2009 Mack GU 713 is the latest service truck for owners Paul Mumford & Paul Mumford Jr. The Mumfords use the truck, with its 5,000-gallon steel Presvac Systems tank — purchased from Com Vac Systems in Enfield, Conn. — to service residential and commercial accounts. Purchased from Ballard Mack in Johnston, R.I., the truck has a Mack MP8 engine, producing 425-hp, and an 8LL Eaton-Fuller transmission. The pump is an LW 825 Utile. The tank has a Garnet electronic level indicator, a sight tube behind the driver's door and four sight glasses at the rear of the tank. It has an 18,000-pound front axle and 52,000-pound rear axle. It also features polished aluminum fuel tanks, air tanks, and battery box; dual aluminum diamond-plated tools boxes and polished aluminum Alcoa Dura-Bright wheels; heated mirrors, and LED work lights around the truck and four strobe lights for safety. The hose trays feature a spray-on liner. ■

#### SHOW US YOURS!

Got a truck with real WOW appeal? Show it off to Pumper readers — and to the whole world through [www.pumper.com](http://www.pumper.com)!

Send photos of your truck after it has been lettered with your company name. Any industry-related truck is acceptable. Please limit your submission to one truck only.

Your submission must include your name, company name, mailing address, phone number, and details about the truck, including tank size, cab/chassis information, pump information, the company that built the truck, and any other details you consider important. In particular, tell us what features of the truck help make your work life more efficient and more profitable. E-mail your materials to [editor@pumper.com](mailto:editor@pumper.com) or mail to Editor, Pumper, P.O. Box 220, Three Lakes WI 54562. We look forward to hearing from you!

## Clean Solutions, Clear Results

- NSF Standard 40 Certified
- Perfect for substandard soils
- Minimal operating cost
- Easy installation and maintenance
- Five year limited transferable warranty
- Over thirty years of manufacturing experience

**hydro-action**  
green from the ground up

**1-800-370-3749 • [www.hydro-action.com](http://www.hydro-action.com)**

# Tough units. Tough company.

Visit us at the  
PSAI Show  
Booth #71



  
FIVE PEAKS TECHNOLOGY  
231.830.8099 | [www.fivepeaks.net](http://www.fivepeaks.net)  
866.293.1502

It's a tough world out there. But you need to know even when things are tough, we're here to help. We've experienced our own pain in this economy, but we've come out on the other side a tougher, stronger, better company than any time in our history. So yeah, we get it.

Now is the time for you to rely on another tough company like yours. Five Peaks is here to serve you, make sure you're 100% satisfied and give you even better products.

As tough as everything is, you deserve something easy. So let us do this for you. Call (866) 293-1502. We'll give you a customized quote to fit your needs with the most competitive pricing in the industry on the best looking units in the industry. You have nothing to lose.

***For more information please contact:***

**North America**

Dave Bamberg • Director of Sales & Marketing  
Toll Free: 888-500-2227 • Cell: 321-239-2450  
Email: [daveb@fivepeaks.net](mailto:daveb@fivepeaks.net)

**International**

Chris Davis • International Sales Director  
Cell: +1-706-459-8022  
Email: [chrisd@fivepeaks.net](mailto:chrisd@fivepeaks.net)

# FRUITLAND VACUUM PUMPS

Eliminate your problems and your competition with one easy package.

All you do is bolt it on, hook it up and go to work. It's that easy.

Available for RCF 500 or RCF 370 packages in diesel, angle gear box, or hydraulic drive.



**Fruitland  
Eliminator  
Packages**



**Used and Proven by World's Top Liquid Vacuum Service Companies.**

**Fruitland Tool & Manufacturing**

*" Committed to Quality, Reliability, and Guaranteed Performance "*

Contact us today: **1-800-663-9003**  
Visit us @ [www.fruitland-mfg.com](http://www.fruitland-mfg.com) For more info.

**TIRED OF GIVING AWAY  
YOUR PROFITS TO OTHERS?**

**CHEMPACE HAS MANY STRATEGIES  
FOR EXPANDING YOUR BUSINESS!**



**NEW  
PACKAGING  
OPTIONS!**

**PRIVATE  
LABELING**

**Increase your profits every time you pump  
with bioForce Packets - Septic Tank Treatment**  
Make an additional \$20.00-\$40.00 profit at every service call!  
Private labeling available at **no charge**.

**chempace**  
corporation

[www.Chempace.com](http://www.Chempace.com)

800.423.5350

DEODORIZING · ODOR CONTROL · CLEANING SOLUTIONS

**The New Way For  
Grease Disposal**

*Does your customer have one?*



Order with or  
without the  
containment  
and save cost

The Outdoor Envirotub is environmentally friendly and made from 100% recycled materials. Lightweight for easy movement. Stores up to 1,200 pounds of grease. Non-stick plastic surface for easy cleaning and eliminates grease build up. Self closing lid to reduce odors and rain water. Built in containment, catches overflow, spills, perfect for coastal communities. Keeps trash areas clean, endorsed by property management and restaurant companies.

The indoor tub made to keep grease thieves away. Stores up to 55 gallons of grease. Fits under most two and three compartment sinks. Perfect for small kitchens with limited space, malls, colleges and food courts.

- > Self Closing Lid
- > Full Containment
- > 100% Recycled Plastic
- > Easily movable

**ENVIROTUB**

PO Box 1343, Corona, CA 92878

[www.envirotub.com](http://www.envirotub.com) **1.866.777.4322**

# TRANSPORT TRUCK SALES, INC.

Ask for Scott or Frank – 888-395-7551  
After hours call Scott at 816-590-4076



## What Does It Take To Be A "Qualified Chassis"?

- ✓ Pass our 12 point checklist. (We send this out with every quote!)
- ✓ Pass a D.O.T. certified inspection!
- ✓ Pass the warranty inspection!

## What Does All This Do For You?

- ✓ Nationwide drive train warranty for 2 years/ 200K miles! (restrictions apply)
- ✓ A tough truck that is ready to work as hard as you do!

**YOUR TRADES ARE WELCOME!**

**Searching For A Brand New Chassis?  
We Have Them In Stock!**



**2001 Mack CH613**, E-7 300 HP, 10 spd, AC, double framed, new 3360 gallon steel vac tank, new liquid cooled HXL-400 Masport vac pump.  
Call For Pricing!  
**2-YEAR 200,000 MILE DRIVE TRAIN WARRANTY**



**2005 Freightliner M-2**, Cat 250, 6 spd, AC, 33# GVW, new 2300 gallon steel vac tank, new Jurop PN-84 vac pump.  
Call For Pricing!  
**2-YEAR 100,000 MILE DRIVE TRAIN WARRANTY**



**2005 Kenworth T-800**, Cat C-15 475HP, 8LL, jakes, 20# fronts, 46# rears, 167K actual miles, 3200 Waste / 300 Fresh Kieth Huber Dominator vac tank, full tilt, full opening rear door, Becker vac pump, Jetter system, hydraulic hose reel, vibrator, all new with the truck. excellent condition, **SAVE HUGE OFF NEW!!!**  
Call For Pricing!



**2003 Peterbilt 330**, Cat 275HP, Allison AUTO, AC, new 2300 gallon steel vac tank, New Jurop PN-84 vac pump.  
Call For Pricing!  
**2-YEAR 100,000 MILE DRIVE TRAIN WARRANTY**



**IN PROGRESS**

**2006 Freightliner M-2**, Mercedes 450HP, 10 spd, jakes, AC, new 3360 gallon steel vac tank, new liquid cooled HXL-400 Masport vac pump.  
Call For Pricing!  
**2-YEAR 200,000 MILE DRIVE TRAIN WARRANTY**



**IN PROGRESS**

**2000 Freightliner FL-70**, Cat 210HP, 6spd, AC, 33# GVW, ONLY 108K actual miles, new 2300 gallon steel vac tank, new Jurop PN-84 vac pump.  
Call For Pricing!

**Delivery Available Anywhere in the Lower 48!!**



**NAWT EXECUTIVE DIRECTOR:** A. Thomas Ferrero, Jr.

**NAWT BOARD OF DIRECTORS:**

Roger Winter, President, Ontario  
 Bruce Fox, Vice President, PA  
 Ralph Macchio, Treasurer, NY  
 Tom Ferrero, Secretary, PA  
 Tom Frank, Past President, OH

Jim Anderson, MN  
 Mark Hacker, IN  
 Jace Ensor, NM  
 Tim Frank, OH  
 Bill Hall, CT  
 Wayne Hudson, DE

Tom Johnson, NY  
 Bob Kendall, WI  
 Frank King, MA  
 Susan Ruehl, OH  
 Carl Stenberg, MI

336 Chestnut Lane • Ambler, PA 19002 • 1-800-236-NAWT (6298) • Fax 267-200-0279 • [www.nawt.org](http://www.nawt.org)

# Join NAWT Training at 2011 Pumper & Cleaner Expo

*By Tom Ferrero*

October is the perfect month to start planning a trip to Louisville, Ky., for the Pumper & Cleaner Environmental Expo International March 2-5, 2011. The National Association of Wastewater Transporters Inc. will offer its two-day onsite inspector training course and two-day, 12-hour operation and maintenance course on Monday and Tuesday, Feb. 28-March 1.

The one-day vacuum truck technician training course also is on Tuesday, March 1.

The inspector course is at the operation level. The first day covers the basics of sewage treatment and system types using a troubleshooting perspective. The second day goes through a step-by-step procedure to conduct a system inspection. It requires attendees to locate and identify all

parts of the system, assess their condition, and determine if they are operating properly. The inspection course is a prerequisite for the operation and maintenance course.

The O & M course concentrates on aerobic tanks, single-pass and recirculating media filters, and chlorination or ultraviolet light disinfection. Sessions also include maintenance of drip irriga-

## REGISTRATION FORM



**NAWT Inspection Training & Certification, Louisville, KY • Feb. 28 - March 1, 2011**  
**NAWT Operation and Maintenance Training & Certification, Louisville, KY • Feb. 28 - March 1, 2011**  
**NAWT Vacuum Truck Technician Training, Louisville, KY • March 1, 2011**

Name \_\_\_\_\_ Company \_\_\_\_\_  
 Address \_\_\_\_\_ City \_\_\_\_\_ State \_\_\_\_\_ ZIP \_\_\_\_\_  
 E-mail \_\_\_\_\_ Phone \_\_\_\_\_ Fax \_\_\_\_\_

**Inspection Training (2 days)**

- |   |                                       |   |
|---|---------------------------------------|---|
| <input type="checkbox"/> Full Registration Fee:                 | <input type="checkbox"/> \$395 Member | <input type="checkbox"/> \$495 Non-Member |
| <input type="checkbox"/> Recertification Fee (Day 1 or 2 Only): | <input type="checkbox"/> \$295 Member | <input type="checkbox"/> \$395 Non-Member |

**Operation & Maintenance Training (2 days)**

- |   |                                       |   |
|---|---------------------------------------|---|
| <input type="checkbox"/> Full Registration Fee:                 | <input type="checkbox"/> \$395 Member | <input type="checkbox"/> \$495 Non-Member |
| <input type="checkbox"/> Recertification Fee (Day 1 or 2 Only): | <input type="checkbox"/> \$295 Member | <input type="checkbox"/> \$395 Non-Member |

**Vacuum Truck Technician Training (1 day)**

- Full Registration Fee:  \$175

**PAYMENT METHOD:**  Check enclosed (Payable to NAWT)  VISA  MasterCard  Discover

Card Number: \_\_\_\_\_ - \_\_\_\_\_ - \_\_\_\_\_ - \_\_\_\_\_ Expiration Date: \_\_\_\_\_

Name on Card: \_\_\_\_\_ Signature \_\_\_\_\_

**Fax or send your form with payment to the NAWT office by Feb. 15, 2011. PRE-REGISTRATION AND PRE-PAYMENT REQUIRED.**

**NAWT, 336 Chestnut Lane, Ambler, PA 19002-1001**

Registrations with payment information may be faxed to 267/200-0279. Questions? Call NAWT at 800/236-6298.





**Presby Environmental Proudly Announces...**

## Advanced Enviro-Septic™ (AES)

*See why Advanced Enviro-Septic™ is sweeping the onsite wastewater treatment industry!*

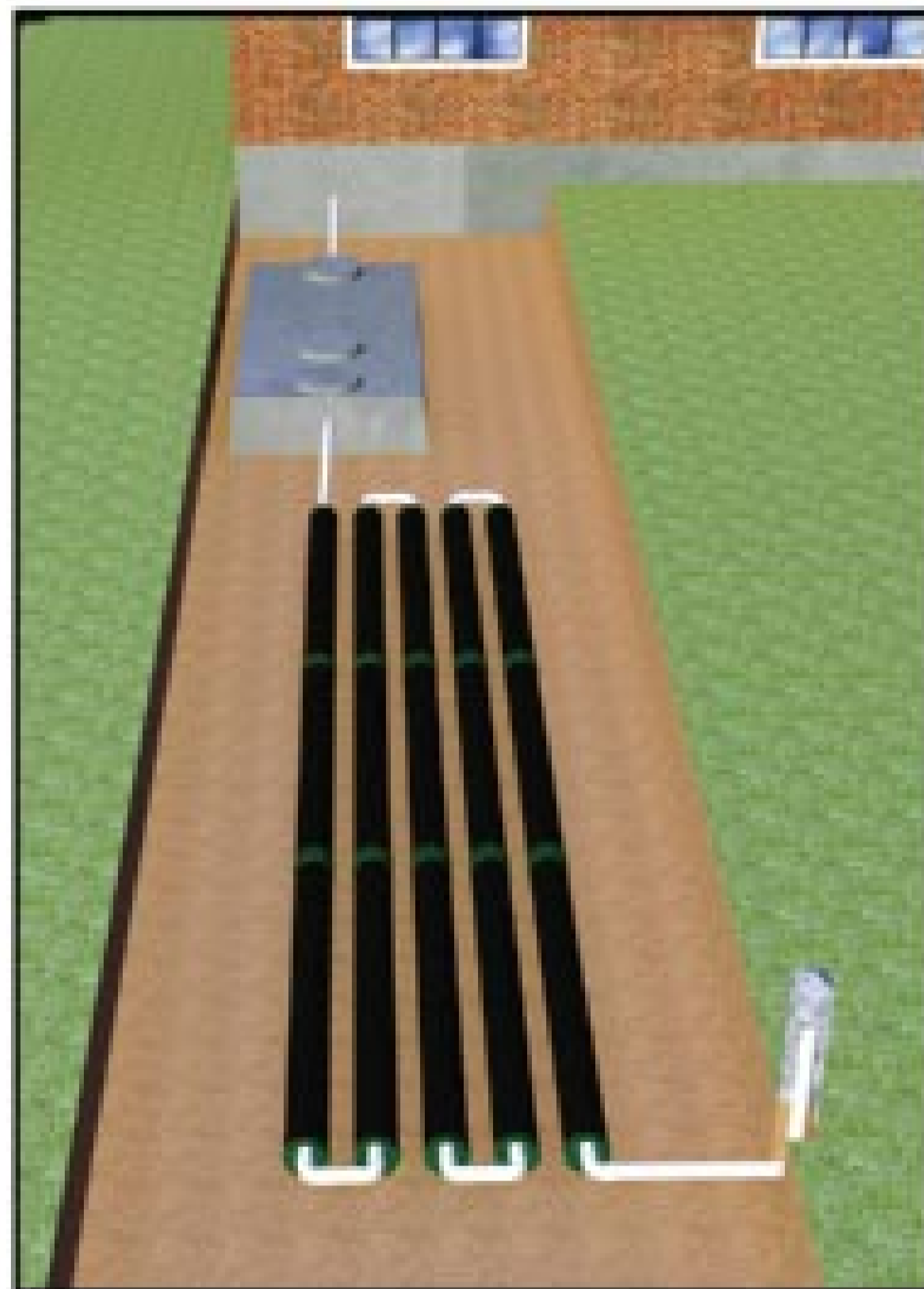

- ✓ **Removes up to 99% of wastewater contaminants**
- ✓ **Treats and disperses in the same footprint**
- ✓ **Passive/non-mechanical**
- ✓ **Cost-effective**



SPD & CTD Models  
Certified to NSF/ANSI  
Standard 40 Class 1

**Made in USA**

*Visit:*

[www.PresbyEnvironmental.com](http://www.PresbyEnvironmental.com)

**800-473-5298**

***The Next Generation of Wastewater Treatment***

tion systems and proper installation of pump stations. Both courses have field opportunities Tuesday morning and a written exam for NAWT certification.

NAWT's vacuum truck technician training course is for new owners and employees who operate vacuum trucks to clean septic tanks, aerobic treatment units, holding tanks or grease traps. It can also serve as a refresher course and overview for experienced operators. Training includes presentations, videos and hands-on exercises with a vacuum truck.

The course includes basic vacuum truck operation, materials to pump and avoid, reasons to manage these materials, pumps, basic science of vacuum and pressurization, truck equipment and components, drive and control mechanisms, basic and advanced pump-out skills and procedures, loading and unloading, safety and emergency response plans, customer interaction and education, manifests and reports, and government regulations. NAWT will list all certified service providers on its Web site: [www.nawt.org](http://www.nawt.org).

### **EDUCATION DAY**

NAWT has a full track of one-hour sessions during Education Day at the Pumper & Cleaner

Expo, Wednesday, March 2. The seminars focus on topics related to treating high-strength waste streams, and troubleshooting drip distribution systems and O & M problems.

Seminar titles and presenters for the 2011 Pumper & Cleaner Expo are: *So You Think You Want to Own a Waste Treatment Facility*, Tom Frank, Tim Frank Septic Tank Cleaning Co., Huntsburg, Ohio; *Grease as a Resource*, Tom Ferrero, executive director of NAWT; *Resource Recovery: Methane and Septage*, Kit Rosefield, Accredited Septic Monitoring, Mi Wuk Village, Calif.; *O & M Problems on Drip Distribution Systems*, Bruce Lesikar, Ph.D., P.E., Texas A & M University; and *O & M Problems with Media Filters*, Dave Gustafson, P.E., University of Minnesota.

### **INSTALLER COURSE**

On Thursday, March 3, COLE Publishing teams with us to offer the NAWT installer course at the Expo. Presented by Jim Anderson, Ph.D., and Dave Gustafson, P.E., from the University of Minnesota, the sessions will cover introduction and site evaluation, system sizing and basic design principles, pumping to systems, installing ATUs, installing for management and trou-

bleshooting systems.

Register for the Pumper & Cleaner Expo NAWT training courses using the form at the bottom of the preceding page or go to [www.nawt.org](http://www.nawt.org). The installer course is included in your Pumper & Cleaner Expo registration fee. NAWT courses are \$395 each for members and \$495 for nonmembers. The NAWT membership fee is \$150.

In addition to those courses, we sponsor training across the country by working with state associations and other industry-related groups. To bring a NAWT course to your area, call Tom Ferrero at 800/236-6298 or e-mail [info@nawt.org](mailto:info@nawt.org). Check [www.nawt.org](http://www.nawt.org) for the latest updates on our training programs and seminars. ■

## **Join NAWT Now!**

**Independent Member** (\$150)

**Company Member** (\$300)

**Associate Member** (\$300)

**State Association Member** (\$100)

*Be a part of the pride and professionalism that all NAWT members enjoy!*

**Contact NAWT today:**

1-800-236-NAWT (6298) Fax 267-200-0279

[www.nawt.org](http://www.nawt.org)

## 450 Gallon Slide In 300 Waste / 150 Fresh

**SHIPS FREE!**

- Electric Start 5.5 HP Honda Conde Super 6 vacuum pump w/ 4-way valve
- 12 V washdown system w/50' hose
- 12 Volt battery
- 30' of 2" fill hose
- 3" Discharge



**\$7,995**

- Self-Contained • Skid Mounted • Lightweight Aluminum
- Easily Maneuvered • Fits Standard Pick-Up

\* Free shipping to 48 continental U.S. states, excludes AK and HI.

## 4200 Gallon Aluminum Septic Tank

NVE 866 – 500 C.F.M., Toolbox

### 2011 International 7500

- 10-Speed, 58,000 GVW,
- 350 H.P. MaxxFORCE 10,
- engine brake,
- differential lock,
- aluminum wheels,
- chrome bumper. Loaded!

**\$121,125**



## 1200 Gallon Restroom Service

Aluminum tank, Masport HXL4 vacuum pump - 160 CFM, 4 way valve, washdown system, remote PTO, toilet carrier, storage cabinet.

### 2011 Ford 550 19,500 GVW

300 Horsepower, automatic transmission, XL trim package.

Toll-Free: **1-888-848-3727**

email: [lctanks@bellsouth.net](mailto:lctanks@bellsouth.net)

fax: 270-898-4055

**LaVerne Charlet** 175 Cascade Drive, Paducah, KY 42003

# L.C. TANKS

Route *Optix* Inc.

**Streamline Operations  
Maximize Efficiency  
Increase Profitability**

**Customer Service  
Optimized Routing  
Visual Dispatch  
Asset Management  
Disposal Tracking  
Customer Billing**



Our look is expensive.... our service is priceless!

[WWW.ROUTEOPTIX.COM](http://WWW.ROUTEOPTIX.COM)

(866) 926-7849

## Biosolids Applicators

2,500 to 6,000 gallon injection or broadcast



Trailer models also available liquid or dry

7,000 gallons per acre at 9 mph

**Moro Pump Sale!**



Bloomington, IL  
1-800-678-2459

**Stahly**  
SINCE 1976

Setting the standard.

[www.stahly.com](http://www.stahly.com)

# Mobile Dewatering Solutions



**Tractor Trailer Unit**  
**H&A Resource Management**  
Versailles, KY Tel: 859-873-3331



**MSD Environmental**  
Centerville, OH Tel: 937-313-9314



**Skid Mounted System**  
**Thunder Bay Casino**  
Sacramento, CA Tel: 209-483-4118

**Industry References:** Synagro Inc. ▪ Blue Heron  
MSD Environmental ▪ Parker Aggregates ▪ LWI, Inc.

**Email:** [kelly@bdpindustries.com](mailto:kelly@bdpindustries.com)  
**Sales:** 518-527-5417  
**Factory:** 518-695-6851  
**Fax:** 518-695-5417

**BDP offers belt press sizes to fit your needs with these advantages:**

- Feed Distributor, Gravity Zone at waist level to operator
- Cake Discharge high enough to discharge directly to truck
- Accessibility for maintenance and cleaning
- Tubular Frame — Stronger & Reduced Corrosion
- Broad range of sizes from tractor trailer, skids, and small pick-up truck units



**Pick-up compatible unit**

Visit us at

**weftec 2010**  
the water quality event™  
Booth 6827

&

**2011 Pumper & Cleaner  
Environmental Expo**  
Booths 7006-7009

**INDUSTRIES**  
[www.bdpindustries.com](http://www.bdpindustries.com)

# LELY

## Commercial Wastehandling Equipment

### Put Our Experience to Work for You

Aluminum Tanks • Full Open Door Hoist Tanks

ASME DOT 407/412 Code Tanks

- Standard and custom tanks
- Carbon steel and aluminum available
- A tradition of reliable service
- Large range of sizes (400 - 6000 Gal.)
- Complete line of parts

## 2010 International



- ◆ Maxforce engine 330 HP
- ◆ 10-speed transmission
- ◆ Aluminum fuel tank
- ◆ Aluminum wheels
- ◆ Chrome sun visor
- ◆ Chrome bumper
- ◆ 3560 gallon steel tank
- ◆ White tank - red hose trays
- ◆ 4" front pumping
- ◆ 4" inlet
- ◆ 6" discharge
- ◆ Jurop vacuum pump 500 plus CFM
- ◆ Air shift PTO
- ◆ 2-Aluminum toolboxes

Call for Special Pricing!

## Portable Toilet Trucks



### Available On All Models

- Hot Shift PTO with Automatic Transmission
- Balanced PTO Axle
- Heavy Duty Toilet Carrier
- Trailer Hitch
- Spring Rewind Reel (Optional Dual Service)
- 2" Bucket Quick Fill
- Driver Side Work Station
- Dual Side Tool Box
- Electric Water Pump 40 PSI 6 GPM (Air Pressurized Optional)
- Coated Water Compartment
- Full Set of Working Lights
- Truck-Lite Lights
- 50 ft. Water Hose with Nozzle
- Vacuum and Pressure Relief Valve

Stock Tanks Available

Financing Available



Lely Manufacturing, Inc.  
 P.O. Box 789 Wilson, NC 27393  
**800.334.2763**  
 sales@lelyus.com

—partners in wastehandling—  
**www.lelyus.com**

## Comfort Elite Restrooms®

There's no limit to our innovation.



New 2010 Model: ADA+4

- MORE Warranty** - 6 year warranty is the longest, most comprehensive in the business.
- MORE Service** - Experience the benefits of a NATIONAL company with more resources.
- MORE Experience** - Wells Cargo has been building the highest quality trailers since 1954.
- MORE Innovation** - New PowerFlush Series and fully compliant roll in/out ADA showers.
- MORE Business** - We NEVER compete against you for rental business. We send you leads!



### Wells Cargo COG

Effective Solutions. Uncompromising Quality.  
 Phone: (888) 574-4222  
 Web: www.wellscargoCOG.com

## Irrigation fittings are for irrigating – NOT vacuum.

How many dollars are you spending **SUCKING AIR?**

Industry-proven, quality vacuum couplings from Bandlock will put money into your pockets.

4" to 12" Male Coupler      4" to 12" Female Coupler      Steel Crown 4", 6" and 8" Press End      Hazardous Material Profile Gaskets (Safety)      Rubber Gaskets

6" and 8" Aluminum Weldon      Aluminum & Steel Pipe

4" and 6" High Abrasive Bulk Nozzles      Special "Y" Reducers      BANDLOCK      Close Tolerance Couplers And Fittings Bring "Safety" To Your Work Place.

EZ Lift Clamps      Standard & Internal 4" to 12"      Wet Valve, 6", 360° Injected      Male and Female 4" to 12" End Plugs

**Recognized as the #1 Relief Valve in the World**

**BANDLOCK Corp.**  
**MADE IN THE U.S.A.**

Call or fax today to get your catalog!  
**1-800-659-2978**  
**www.amesbury.com**  
 Superior "Quick" Connect Vacuum And Pressure Couplings And Accessories

# Why Pay More? No Water Added!

**New**

**Powerful, Reliable Portable Toilet Odor Control**

**AQUA STRENGTH™**

# 150

**Only  
\$22.00  
PER GALLON**

**Non-Formaldehyde  
Syrup-Concentrate  
Non-Staining Deep Blue  
Great Performance**



**Any Size  
1, 5, 7, or 55 Gallons**

# SURCO®

**Call Today: 1-800-556-0111**

SURCO PRODUCTS • 292 Alpha Drive, Pittsburgh PA 15238 • 1-800-556-0111 • 412-252-7000 • fax 412-252-1005  
[www.surcopt.com](http://www.surcopt.com)



Jim Miller

## Walker Group Names Miller VP-Sales and Marketing

Jim Miller has been named vice president of sales and marketing for Walker Group Holdings and its transportation tank companies. Miller will integrate the sales and marketing efforts of WGH's seven transportation tank companies: Brenner, Bulk, Defense, Garsite, Progress, TST and Walker. As part of the reorganization, Thomas Ballon was appointed vice president of sales for the Brenner and Bulk product lines.

## Nature's Calling Acquires Fenn-Vac

Russ Perkins, owner of the portable restroom company Nature's Calling in Charleston, S.C., has acquired Fenn-Vac, the solid waste handling company which he helped start in 1983. Perkins sold his interest in Fenn-Vac in 1995 and later bought the Fenn-E-Let restroom business, which was renamed Nature's Calling. The deal was closed in July. Terms were not disclosed. Fenn-Vac has averaged between \$3 million and \$5 million in sales the past three years. Brian Wintjen is general manager for Nature's Calling and Fenn-Vac, Jeff Forslund is division manager and Mike Williams is operations manager.

## McKee Launches Explorer Line Web Site

McKee Technologies Inc. has launched a new Web site, [www.explorertrailers.com](http://www.explorertrailers.com), for its Explorer line of portable restroom products. The interactive site is designed to connect portable sanitation contractors with Explorer distributors. It also features detailed product information.



## Mi-T-M Launches Product Web Site

Mi-T-M Corp. has launched a new product Web site, [www.mitm.com](http://www.mitm.com), that enables users to search by product series, specification or model for any of the company's pressure washers, air compressors, portable generators, water treatment systems, wet/dry vacuums, jobsite boxes and portable heaters.

## SJE-Rhombus Hosts HD Supply, Snider

SJE-Rhombus hosted personnel from HD Supply in Statesville and Charlotte, N.C., and Snider Inc. for an educational course on control panel operation at its Detroit Lakes, Minn., facility in June.

## Wastequip Expands Leadership Team, Names Dealer

Wastequip has named Steve Svetik chief financial officer, Rusty Andrews chief information officer, Sherri Satterfield vice president of human resources, Shawn King vice president, marketing, and Amy Wright director of marketing communications. The company also named CES as a dealer for its Gailbreath brand of hoists in the Carolinas.

## Vanair Launches Web Site

Vanair has launched a new Web site, [www.vanair.com](http://www.vanair.com), for its All-in-One power systems, including the Air N Arc air compressor/generator/welder/battery booster power system. ■

**The Smart Choice**

**Low Price • Big Value**

**smart vac**  
VACUUM ADVANCED

[www.smartvacequip.com](http://www.smartvacequip.com)  
888.408.6716

RENT ME  
LIKE ME  
BUY ME

KMH EQUIPMENT COMPANY  
SALES • SERVICE • SUPPORT

## SOFTWARE FOR YOUR INDUSTRY

Over 28 years experience • Easy to use • Affordable • Powerful



Want to increase profits?  
...Improve your operation?  
...Become more efficient?

- Summit Service Profit Builder™
- Summit Rendering Profit Builder™
- Summit Rental Profit Builder™

Customer records, billing, inventory control, operations management, dispatching, mapping, route optimization, and more.



WATCH DEMOS ON LINE!...or call for a personal guided tour



**Ritam Technologies, LP**

Sales: USA 800-662-8471 • Int'l: 208-629-4462  
Email: [info@ritam.com](mailto:info@ritam.com) • Web: [www.ritam.com](http://www.ritam.com)



Toilet Transporters



Comfort Stations



Handwash Trailers

# EXPLORER

We Have Your Size...  
**1 to 24**

Explorer improves transport safety by directly clamping each toilet skid to the specially designed carrier slats on the trailer bed. Flexibility for the many styles of portable toilet skids available today.



**Now Available!**

Hot Dip Galvanized Frame and Wheels

[explorertrailers.com](http://explorertrailers.com)

Explore the Finest In Sanitation!

Contact an Associate In Your Region ...

#### Alberta

Ted Hoover  
Crossfield, AB  
Tel: (866) 587-7262  
Fax: (403) 946-4110

#### Florida

Steve Baie Ent.  
Apopka, FL  
Tel: (407) 790-4358  
Fax: (877) 697-8383

#### California

Plumas Sanition  
Portola, CA  
Tel: (530) 832-0370  
Fax: (530) 832-0373



#### Ontario

McKee Technologies  
Manufacturer  
Elmira, ON  
Tel: (866) 457-5425  
Fax: (519) 669-8331

#### Minnesota

Satellite Industries  
Minneapolis, MN  
Tel: (800) 328-3332  
Fax: (763) 553-1905

#### Colorado

Columbia Sanitary  
Golden, CO  
Tel: (303) 526-5370  
Fax: (303) 526-9686

#### Texas

Tom Woyt  
Jacksonville, TX  
Tel: (903) 586-6493  
Fax: (903) 541-0874

*Quality Tanks ... That's How We Roll!*



Built right, to your specs. Find out what many OEMs and operators already know—Vacutrux custom tanks save you time and money! Quality Tanks, Pumps, Components, all shipped ready to assemble and install.



only from  
**vacutrux**

1-800-305-4305  
[www.vacutrux.com](http://www.vacutrux.com)

Let's Talk  
**Truck Mount**



**753**

Air Cooled

Liquid Cooled

**753LN**

Let's Talk  
**Performance**

### Wallenstein 753A, 753LN, 753LNi

The Wally 753 is one cool vacuum pump. Air cooled, liquid cooled, or liquid cooling with internal air injection. We're talking real performance—350 CFM @ 15 "Hg vacuum, and 28 "Hg vacuum capability (Rated at 1150 RPM). Widest vanes in the industry for long service life. And like all Wallenstein Pumps, the 753 is easy to open and inspect. Made in North America, sold worldwide. Why not have your tank builder quote a **Wally?**

The  
**Toughest**   
out there... Let's Talk!

**1-800-801-6663**

[www.wallensteinpumps.com](http://www.wallensteinpumps.com)



**wallenstein**  
vacuum.pumps

# PARTS • SUPPLIES • EQUIPMENT



- Vacuum Trucks
- Sewer / Jetter
- High Pressure
- De-Watering



**Vacuum Pumps**



**Transfer Pumps**

- HOSE**
- Suction
  - Transfer
  - High Pressure

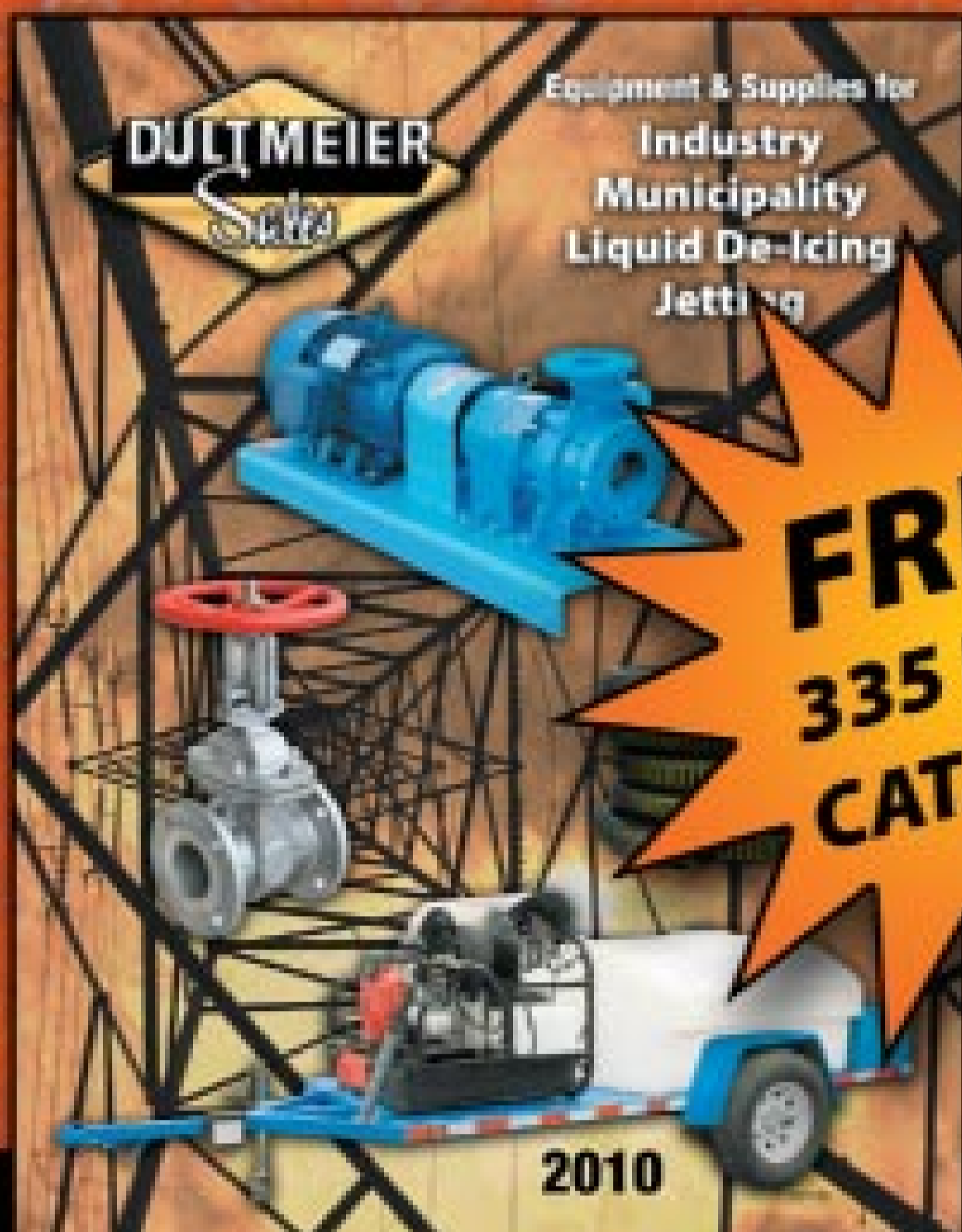

**FREE  
335 PAGE  
CATALOG!**



- VALVES**
- Lever • Ball
  - Solenoid
  - Piston



**dultmeier.com**

**1-800-228-9666**  
Omaha, NE

**1-800-553-6975**  
Davenport, IA

## BACK HURTING

FROM PUMPING SEPTICS OR GREASE TRAPS?

**END THE PAIN!**



The Ultimate hand-held, powered agitator for septic tanks, grease traps and car wash pits

**WWW.CRUSTBUSTERS.COM • 888.878.2296**

Schmitz Brothers L.L.C.  
PHONE 763.878.2296  
FAX 763.878.2299



ASK ABOUT OUR  
"BUSTER BRACKETS"  
FOR TRUCK MOUNTING

**CRUST  
BUSTERS**



Count on  
**DEL VEL CHEM**  
to always lend a  
Hand!

Offering A Complete Line  
Of Portable Toilet  
& Septic Needs

Environmentally Friendly Products  
Portable Toilet Chemicals – Paper Products  
Urinal Blocks – Hand Sanitizers – Graffiti Remover  
Deodorant Sprays – Cleaners

**Del Vel Chem**  
COMPANY

**Family Owned and Operated Since 1974**

250 Old Marlton Pike • Medford, New Jersey 08055  
609-714-2424 • Fax: 609-714-3030 • 800-699-9903 • www.delvel.com





THANKS, RONNIE SIPES!



STAINLESS STEEL & STEEL UNITS - CALL FOR INFORMATION



TANKS BUILT TO YOUR DESIGN

# PUMP DISTRIBUTOR

- \* BATTIONI
- \* BOWIE
- \* FRUITLAND
- \* JUROP
- \* MASPORT
- \* MORO

**Pump Rebuild Kits In Stock**

**CALL TODAY FOR INFORMATION OR PRICES ON TANKS, PUMPS AND ALL PARTS**

Secondary Shutoffs



12" Primary Shutoffs



Sight Glasses, Valves & Couplings



21" & 36" Manways

### BASE TANKS INCLUDE:

1/4" Thick Steel • Pipe Reinforced Baffles • Primary Shutoff Flanged and Dished Heads • 21" Top and Rear Hatches Full Length Under Carriage on Bottom of Tank

### BASE TANK PRICING

2100 GALLON .....	\$5800	3360 GALLON .....	\$8140
2500 GALLON .....	\$6740	3570 GALLON .....	\$9000
3000 GALLON .....	\$7575	4000 GALLON .....	\$9920



**800.364.7307**

2100 EAST BOOTH ST. • SEARCY, AR 72143  
Fax: 501.279.0003 • E-mail: sbs@cdlworld.net

## We've Got the Money!

*...And We Are Here For You.*

- New & Used Equipment
- Exceptional Customer Service
- Flexible Payment Options
- Dedicated to Finding You Our Best Available Rates



*"THE SOLUTION TO ALL YOUR FINANCING NEEDS."*



Chuck Territo



**Granite Leasing Co.**

406-892-5068 • 800-246-7997

chuck@graniteleasing.com • www.graniteleasing.com

## The COMPLETE CCTV Sewer Inspection System from CYCLOPS ELECTRONICS

The CYCLOPS Vehicle Mounted Color TV System comes with choice of color camera and transporter.

The Economical Valu-Pac Color System is easily rolled on its own wheels and transported by pickup or van.

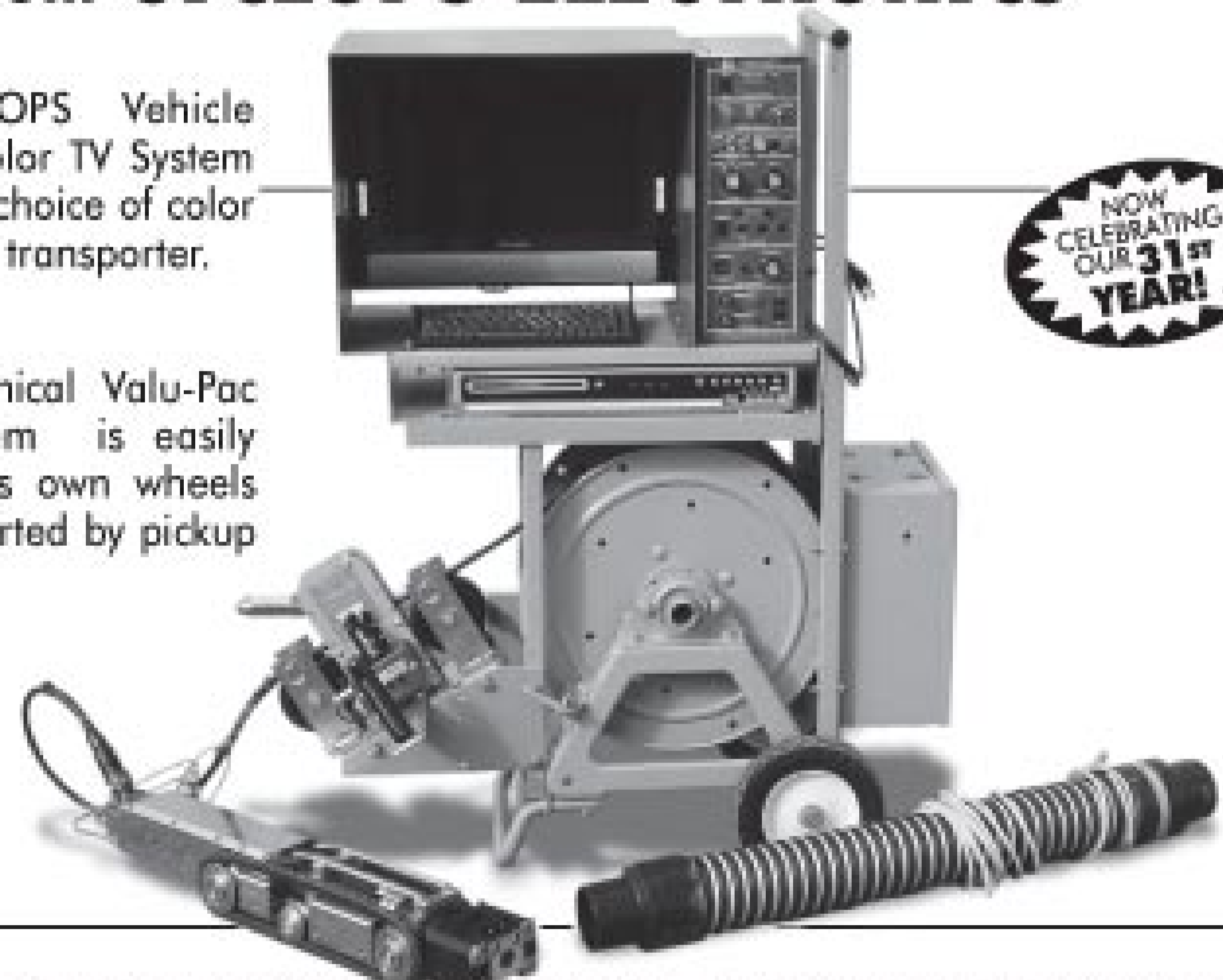

**NOW CELEBRATING OUR 31st YEAR!**

PORTABLE OR MOUNTED ON YOUR CHOICE OF VEHICLE



*"Known for Prompt Service!"*

**CYCLOPS ELECTRONICS, INC.**  
Manufacturer of Quality Sewer TV Systems Since 1978

123 Commerce Ave. | Boerne, TX 78006 | Phone: 830-249-9756  
Fax: 830-249-8535 | E-mail: cyclopstv@beecreek.net | www.cyclopstv.com

**DEALERSHIPS AVAILABLE IN SOME AREAS**

# Vacuum Trucks *Can* Compete with Combo Trucks



Power Booster™ can be used in any environment: **Hazardous & Non-hazardous** job sites.

Engineered, rugged, lightweight construction make the Power Booster™ the ultimate pumping solution. Unsurpassed execution in highly viscous applications.



Standard vac trucks will compete with any combo truck by adding a Power Booster™. Utilizing our fast load technology will enable you to pump solid columns of fluid faster and higher than any combo truck.

**Patented Technology for the Pumping Industry**

Perfect for *Every Job!*

- Loading and Off Loading Barges
- Oil Spills & Chemical Releases
- Emergency Response
- Sewer & Septic
- Agriculture/Animal Byproducts
- Grease Traps/Grit Traps

**POWER BOOSTER**



**PL** Pressure Lift Corp

**972.355.0550**

**pressurelift.com**

Call for a **FREE Demo DVD**

# ERICKSON TANK & PUMP

TANK SIZES FOR ALL YOUR PUMPING NEEDS!



TANDEM PUMPERS WITH DROP AXLE

TRAILER MOUNTED VAC/PRESSURE TANKS



PUMPERS UNDER 26,000#

Check Our Web Site for Current Inventory!

**"Tanks" for your business!**

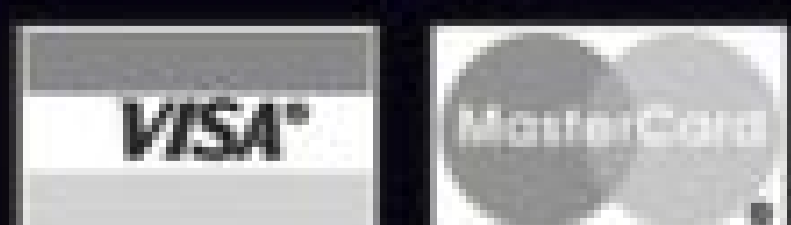

**509.785.2955**

**WWW.ERICKSONTANK.COM**



## Heavy-Duty Towable Backhoe

FAST • AFFORDABLE • COMPACT • DURABLE

Gets you to the job site fast without secondary equipment!

- 18 hp engine
- Digging depth up to 8 feet
- Hydraulic drive for job site mobility
- Torsion block suspension for easy towing
- Quality machine – Built to last!

• Used Machines Available •



**GO • FOR • DIGGER**

**www.gofordigger.com**

1681 Halleck Rd. • Morgantown, WV 26505  
304-296-7000 • Fax: 304-296-5034

# WORKING HARD FOR YOU

AT JACK DOHENY COMPANIES, WE BELIEVE THAT YOUR EQUIPMENT COMPANY SHOULD WORK AS HARD AS YOU DO. JACK DOHENY COMPANIES WORKS HARD TO OFFER THE MOST COMPREHENSIVE PROBLEM SOLVING SOLUTIONS FOR YOU, INCLUDING:

- RENTALS - LARGEST AND NEWEST FLEET IN THE INDUSTRY
- REMANUFACTURED EQUIPMENT - NEW MACHINE PERFORMANCE AT A USED MACHINE PRICE
- CREATIVE FINANCE PACKAGES - MAKING IT AFFORDABLE TO GET THE EQUIPMENT YOU NEED
- MOST KNOWLEDGEABLE STAFF - ALL THE KNOWLEDGE TO KEEP YOU ON THE JOB

FOR MORE INFORMATION ON HOW JACK DOHENY COMPANIES IS WORKING HARDER FOR YOU, GO TO OUR WEBSITE.

[WWW.DOHENYSUPPLIES.COM/WORKING](http://WWW.DOHENYSUPPLIES.COM/WORKING)

**Jack Doheny Companies** 

*"World's Largest Distributor of Sewer Cleaning and Industrial Air Handling Equipment"*



**888-370-0130**

## Petersen® Pipe Plugging Systems



### Economical Hot Tap Plugging Systems

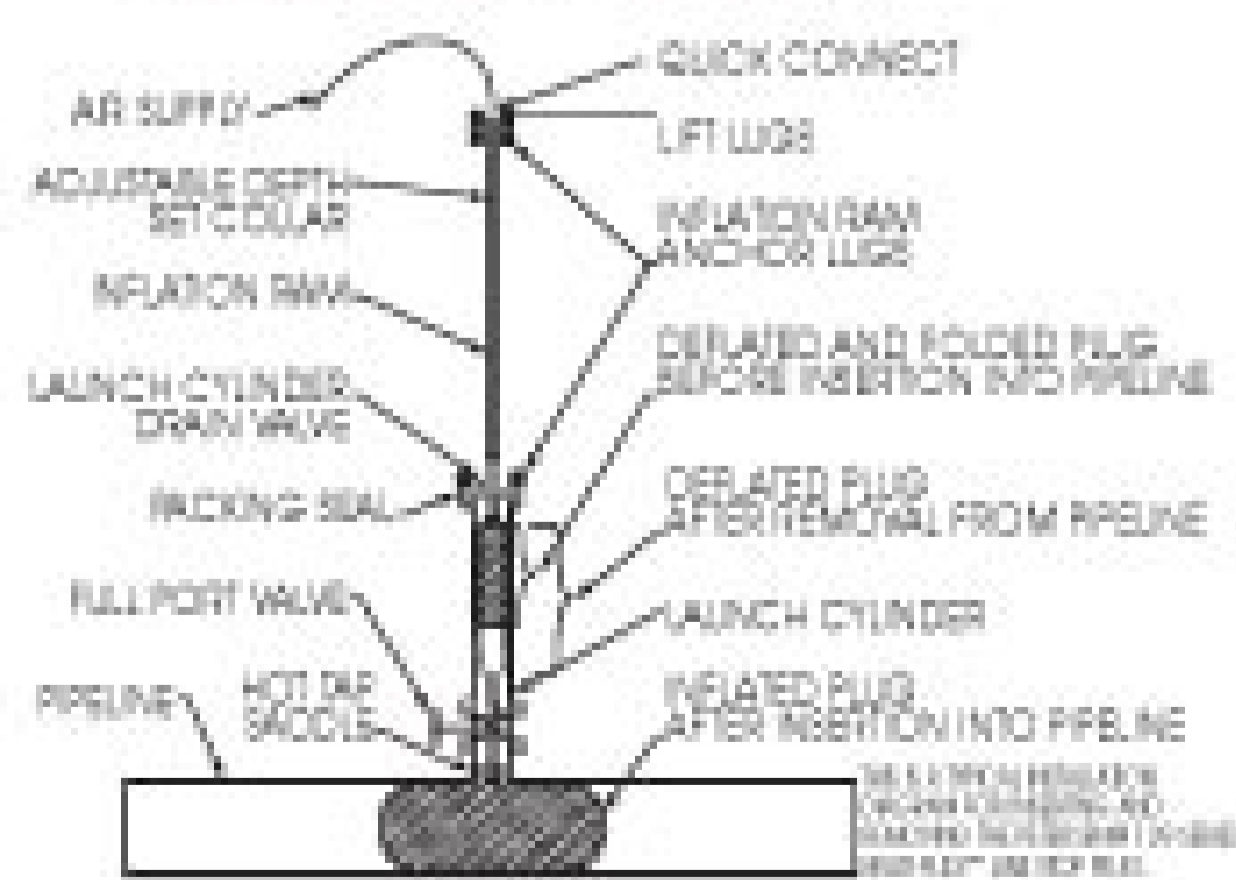

Pipe Plugs and Packers for all your Pressure, Chemical, and Temperature Requirements. Call us to quickly customize a pipe plug or plugging system for your specific application.

[www.pipeplug.com](http://www.pipeplug.com)

**Petersen** PRODUCTS COMPANY  
Serving Professionals Since 1916

PHONE 800.926.1926 OR 262.692.2416  
FAX 800.669.1434 OR 262.692.2418

An ISO 9001/Q 9001 Certified Company

See Our Complete Line at:  
[www.grnleafinc.com](http://www.grnleafinc.com)



**Manufacturer of Liquid Handling Products**

P. O. BOX 88 • FONTANET, IN 47851 USA • P/ 800-654-9808  
F/ 812-877-4278 • W/ [www.grnleafinc.com](http://www.grnleafinc.com) • E/ [sales@grnleafinc.com](mailto:sales@grnleafinc.com)

## Conde ProVac Services Grease Traps, Hard to Reach Restrooms

The redesigned, heavy-duty **Conde ProVac** portable vacuum and pumping service unit from **Westmoor Ltd.** offers pumpers more convenient operation, thanks to features like an integrated hose rack, a 25-foot retractable electric cord and a



relocated suction-hose connection.

"Previously, the suction hose connected on the back of the unit and the on/off controls were in the front, which made it difficult to work in the tight spaces where many grease traps seem to be located," says Robin Hendry, president and owner of Westmoor. "The hose rack and retractable electric cord reel makes it more convenient than carrying a hose and extension cord separately."

The maneuverable ProVac can service grease traps, remote portable restrooms and other sites where access is difficult for vacuum trucks and larger hoses. It's available in stainless steel or aluminum models, which weigh 325 and 250 pounds, respectively. The unit measures 24 inches wide, 50 inches long and 45 inches high and fits through standard building and cargo-van doors.

The unit's 35-cfm pump produces 16 inches Hg of operating vacuum, operating pressure of 5 psi and a pumping flow rate of

up to 120 gpm. A flip of a switch converts the unit from vacuum mode for cleaning to pressure mode for off-loading waste.

Other features include a 52-gallon tank; easy-access front controls; built-in charcoal exhaust deodorizer; quiet operation (69 decibels at 10 feet); 1.5-hp motor; an automatic oiling system; a built-in tool holder; an electronic float-valve shutoff; a liquid-filled vacuum/pressure gauge; an oil-catch muffler with drain; a 2-inch-diameter, 10-foot-long flexible suction hose with wand; heavy-duty wheels and front-swivel casters; a hand parking brake; and a vacuum/pressure relief valve.

For more information, call 800/367-0972 or visit [www.westmoorltd.com](http://www.westmoorltd.com).

## Pat's Pump Introduces Oil Skimmer Barge

The 1,000-gallon oil vacuum reclamation skimmer barge from **Pat's Pump & Blower** features surface layer skimmer heads designed to pick up more oil than water. A vacuum wand on rollers is made to

pick up oil on beaches. The 25-foot by 10-foot barge is made of 5052 marine grade aluminum and is foam filled. Powered by a 40-hp Mercury engine, payload is 13,000 pounds. The barge has a Hibon 2053 blower driven by a 24-hp Honda engine with four-way valve. 800/359-7867; [www.patspump.com](http://www.patspump.com).



## CECOR Offers Sump Cleaner

The sump cleaner from **CECOR** uses a high suction lift to remove sludge from depths up to 15 feet. The unit, with pump-in, pump-out capability, can be used with a filter that separates solids from liquids. The pump can be maneuvered by one person for hauling between disposal or collection. The system is powered by a 20-hp twin-cylinder engine designed to pump up to 110 gpm. Electric and air units are available. 800/356-9042; [www.cecort.net](http://www.cecort.net).



## Liberty Pumps Introduces PC-Series

The PC-Series pump from Liberty Pumps combines a primary 120-volt sump pump with a 12-volt DC backup pump in a factory assembled unit. Available in 1/3- and 1/2-hp, the pumps use 5.2 and 7.5 amps, respectively. In the event of a power outage or main pump failure, the 12-volt DC pump will take over automatically to protect against flooding. 800/543-2550; [www.libertypumps.com](http://www.libertypumps.com).



## Infiltrator Introduces 300-, 500-Gallon Tanks

The TW-Series Septic Tank line from Infiltrator Systems Inc. now includes 300- and 500-gallon tanks. The triple-wall tanks feature a reinforced access port. The rotomolded tanks are designed for watertight performance and are available in sizes from 300 to 1,500 gallons. 800/221-4436; [www.infiltratorsystems.com](http://www.infiltratorsystems.com).



## Coxreels Offers Wand Holder for 1125 Series

A wand holder has been added to the 1125 Series hand-crank and motorized reels from Coxreels. The aluminum holder has a black powder coat finish and measures 24 inches long with a 1.6-inch diameter. It can be mounted on all four reel locations, including the left, right, front and rear sides of the A-frame base. 800/269-7335; [www.coxreels.com](http://www.coxreels.com).



## Clarus Offers Turbine STEP System

The Turbine STEP System from Clarus Environmental is designed for simplex or duplex applications in a single polyethylene pump vault. Made to fit most specifications, the system is designed for free-standing or suspended applications. The deep-pleated filter design yields high surface area and is easy to remove and clean. 800/928-7867; [www.clarusenvironmental.com](http://www.clarusenvironmental.com). ■

**FLEX-TANKS**  
INSTANT WATER & WASTE HOLDING

*"Just Unfold & Fill"*

2000 Gal. AQUA-FLEX™  
Pillow-Style Bladder Tanks

- CONSTRUCTION SITES
- EMERGENCY RESPONSE
- SPECIAL EVENTS

- ✓ For Potable, Grey or Waste Water.
- ✓ Standard Sizes from 100 to 100,000 Gal.
- ✓ Folds Compactly to Store and Transport.
- ✓ Quick-Ship From Our Inventory.
- ✓ FUEL BLADDERS ALSO AVAILABLE.

Fast Worldwide Delivery from: ATL Ramsey, NJ [atl@atline.com](mailto:atl@atline.com)  
**800-526-5330** [www.pillowtanks.com](http://www.pillowtanks.com)



ITT has over 35 years of experience designing and building a wide range of custom stainless steel and aluminum products, featuring a variety of code and non-code vacuum, truck-mount and full-size tank trailers.

With our expansive facility and highly trained welding and fabrication team, we can deliver even the most challenging project on-time and on-budget.

National Board "R" Stamp  
ASME "U" Stamp  
D.O.T. Registered &  
Design Certified Engineers  
D.O.T. Inspections Including  
V, I, K, P, T and UC Tests  
Tank & Pump Replacement  
Major Rebuild & Rollover Repair

**417-326-8885**  
[www.indtank.com](http://www.indtank.com)

Stainless Steel Aluminum  
Truck-Mount Tanks

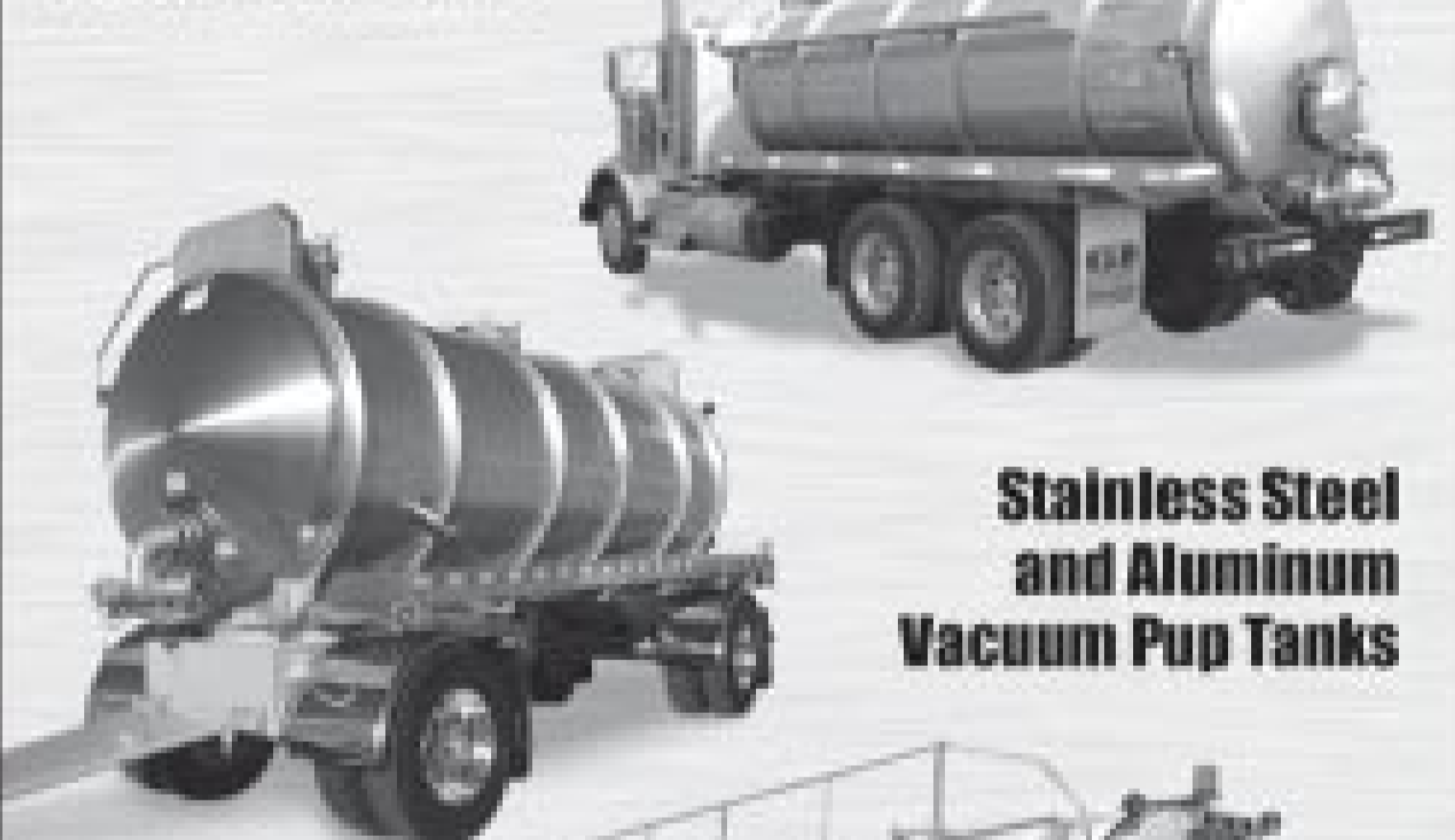

Stainless Steel  
and Aluminum  
Vacuum Pup Tanks



Stainless Steel  
and Aluminum  
Vacuum Tank Trailers

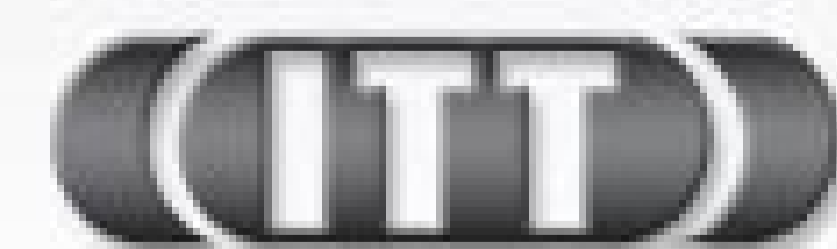

**INDEPENDENT  
TRUCK TANK LLC**  
TANKS • TRAILERS • REPAIR

Building a Reputation Based on Quality, Innovation and Customer Commitment

# HOSE ASSEMBLIES & ACCESSORIES

**We Sell  
The Good Stuff**  
Why buy anything else?



- LIQUID WASTE • PETROLEUM • BIO-DIESEL • WASTE WATER • GREASE TRAP • CHEMICAL
- SEWER CLEANER • JETTING • PRESSURE WASHER • MUNICIPAL VACUUM • LEAF & GRASS COLLECTION

## ABBOTT RUBBER COMPANY, INC.



1700 NICHOLAS BLVD. • ELK GROVE VILLAGE, IL 60007 • 800.852.1855  
E-MAIL [sales@abbottrubber.com](mailto:sales@abbottrubber.com) • WEBSITE [www.pumperhose.com](http://www.pumperhose.com)

## PORTABLE HEPA FILTRATION UNIT



**Filters:** (4) Replaceable elements: 24" x 24" x 11 1/2", 37 lbs. each  
Filter element part number: 3000-01278  
**Unit Rating:** 8000 CFM @ 0.50 in. H<sub>2</sub>O  
**Temperature Rating:** 200°F  
**Inlet:** 12" Diameter  
**Efficiency:** 99.97% @ 0.30 Micron  
**Dimensions:** 41" W x 42" H x 65" L  
**Weight:** 700 lbs.

Protect the environment from harmful waste products while complying with the EPA Clean Air Act with POWER VAC's custom portable HEPA filtration unit. Providing the highest level of efficiency, our HEPA unit is easy to use to provide you with supreme protection and convenience at an affordable price. Call us today for more information.

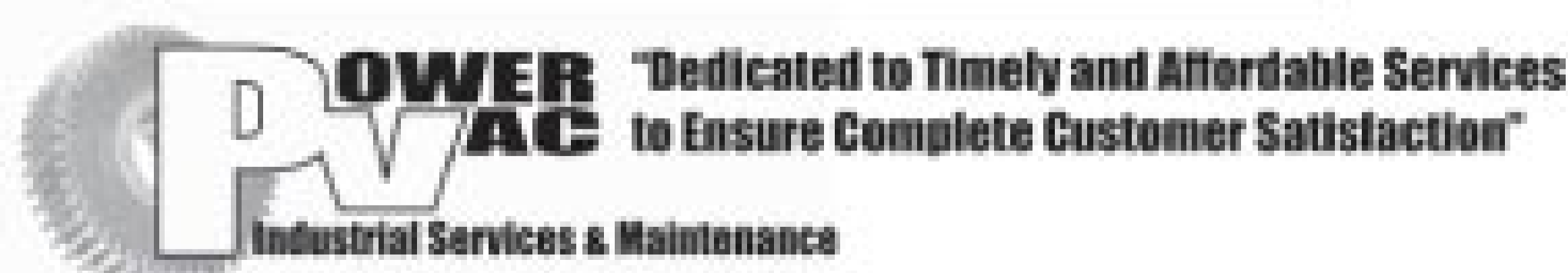

W228N2792 Duplainville Road, Unit G • Waukesha, WI 53186 • P. 262.542.8989 • F. 262.542.6262 • [www.powervacinc.com](http://www.powervacinc.com)

## Custom Built YOUR Truck or Pull-type Chassis or OURS



- Septic Systems
- Municipal Waste Control
- Ag Operations
- Supplier for Brass or Stainless Steel Gate Valves
- Vacuum Pumps of All Sizes

Call Kevien Schroeder Today! 1-800-795-8551 ext. 124

## Vertical Electric Pump

Agitate, transfer or top fill hauling units. Choose from standard lengths of 4' - 6' - 8' - 10' - 12', other sizes available upon request

**Galvanized Construction!**



## BALZER INC.

STEWARDS FOR AG ENVIRONMENTS

CO. RD. 27, Box 458  
Mountain Lake, MN 56159  
1-800-795-8551  
[www.balzerinc.com](http://www.balzerinc.com)



## Seal it Tight! Seal it Easy! Seal it Fast!

- Easy 10 minute installation!
- Secure fit for all systems!
- Made & sold by septic installers!
- Prevent ground water infiltration and save money at the same time!



Apply foam sealant to tank.



Place ring over opening and apply foam.



Place plastic maintenance pipe on ring.



Install lid.

For more information, call us today!

**BrenLin Company, Inc**  
Manufacturers of Seal-R™ Products  
Herman, MN  
**888-606-1998**  
Fax: 320-677-3001 • E-mail: brenlin@frontiernet.net  
[www.seal-r.com](http://www.seal-r.com)

Are you tired of using risers that are too tall or too short for the job you are completing?

Plastic riser pipe will give an exact height each time. Try our system and you will never have to carry concrete pipe and lids again. Save time by not having to assemble multiple sections.

- Seal-R™ Lids Available in 12", 15", 18", 24", 30", 36"
  - Seal-R™ Rings Available in 12", 15", 18", 24", 30", 36"
  - Inner Safety Lids Available in 18", 24"
- Seal-R™ Lids can be personalized

## Portable Restroom Trailers



8 Restroom . .	\$4500
10 Restroom. . .	\$5000
14 Restroom. . .	\$5600
16 Restroom. . .	\$5900
20 Restroom. . .	\$7000

Call about our new design to haul handicaps  
Used trailers also for sale

## Steel Tanks



Polished Aluminum Skirting and Tool Boxes

- NEW • 2011 Dodge, 4x4, 1,000 Waste, 300 Fresh .....\$67,500
- NEW • 2011 Ford 550, 950 Waste, 330 Fresh.....\$63,000
- NEW • 2011 Dodge 5500, 1000 Waste, 300 Fresh New 4x2 \$64,000
- 2005 International, New 1500 Waste, 350 Fresh.....\$47,500
- 2001 International, New 2300 Gallon Tank.....\$37,500

## Trailer Mount Slide-in Tank

600 gallons waste/200 gallons fresh water.  
\$14,000



We stand behind our trucks and trailers!

SLIDE-IN UNITS & USED TRUCKS AVAILABLE / MASPORT, JUROP & CONDE VACUUM PUMPS

CHECK OUR PRICES

## LANE'S VACUUM TANK, INC.

3133 VANZORA RD. • BENTON, KY 42025

800.592.3308 • 270.527.9945

RODNEY LANE'S CELL 270.832.3793

# ART'S TRUCKS & EQUIPMENT

View Our Entire Inventory  
Online: [www.artstrucks.com](http://www.artstrucks.com)  
3001 West Expressway 83  
McAllen, Texas 78503  
956.686.2326 Fax 956.686.5179  
**1.800.292.7007**  
[www.artstrucks.com](http://www.artstrucks.com)

1999 VOLVO Combo Sewer Truck, VOLVO-275 HP Diesel Engine, Allison 3560 Automatic Trans., A/B, A/C, 55,604 Miles, Vac-Con Sewer Cleaner, John Deere Rear Diesel Eng., Lot #2815680 - \$55,500



2000 Chevrolet Vacuum Truck, Cat 3126 Diesel, Allison 3060 Auto Trans., A/B, A/C, 2,250 Gal. Vacuum Tank, Magnum Pump, 3 In. Intake Valve, 4 In. Discharge Valve, 14,635 Miles. Lot #2815633 - \$29,500

2000 Sterling Combo Sewer Truck, Cat 3126 Diesel, Allison 3060 Auto Trans., A/B, Vactor 2110-J4F Sewer Cleaner, JD Rear Engine, 6 Yd. Debris Tank, 76,004 Miles. Lot #3016311 - \$75,500



1994 Ford Combo Sewer Truck, Cummins 8.3L Diesel, Standard Trans., A/B, Vactor 2103 Sewer Unit, 18,854 Miles, Ex-Municipal Truck, Lot #2915929 - \$45,500



"Dedicated to Timely & Affordable Services to Ensure Complete Customer Satisfaction"

Quality Workmanship • Professional Service • Competitive Prices • Guaranteed Satisfaction

### REPAIR & REMANUFACTURE

- Industrial Blowers
- Transfer Cases
- Vacuum Loaders
- Water Pumps
- Pump Trucks



### SALES

- Blowers
  - Used Equipment
  - Aftermarket Parts
  - Flats No More® Tire Sealant
  - Klenztone® Masonry Cleaner
    - Lindhorst Nozzles
  - Portable HEPA Filtration Units
- VACUUM TRUCK REBUILD**
- Guaranteed OEM Parts
  - Work completed by factory trained technicians
  - Fast turnaround time



No Minimum Orders. We service all major manufacturers equipment.

Tired of not finding what you want when you want it? Tired of no one having inventory and not being in a rush to inform you? Does it seem that you can't find what you need or anyone who knows what you want? Does it seem like you're only important to the OEM's when you're buying new equipment? Well we answered YES to all of these questions also. That's why at Power Vac Inc we have a 90% customer retention rate. We know what's important, especially these days, TIME! So the next time you need parts, service or technical assistance call Power Vac Inc, the people who know what's important to you!

Visit Us Online at [www.powervacinc.com](http://www.powervacinc.com)

W228 N2792 Duplainville Road Unit G Waukesha Wisconsin 53186 P.262.542.8909 F.262.542.8262

By **Scottie Dayton**

## **WISCONSIN: WOWRA Pursues Partnership with Realtor Group**

The Wisconsin Onsite Water Recycling Association met with the Wisconsin Realtors Association to educate them about the Certified Private Onsite Wastewater Treatment System Evaluator Program and the need for uniform standards statewide.

The state onsite association developed its certification program four years ago to standardize onsite inspections. The goal of the meeting was to show Realtors the value of the program so that they and lenders would help create a demand for it. The state has 70 certified inspectors. For more information, call Ann Gryphan at 608/256-7757 or e-mail [agryphan@ekgmail.com](mailto:agryphan@ekgmail.com).

## **CALIFORNIA: COWA Accredited**

The California Department of Public Health has approved the California Onsite Wastewater Association as an Accrediting Agency for the Registered Environmental Health Specialists CEU program. The organization's Onsite Wastewater Treatment System Controls course and all other training provide required CEUs for health specialists. Call Evelyn Rosefield at 530/321-2207 or e-mail [cowaemail@gmail.com](mailto:cowaemail@gmail.com).

## **ALABAMA: Homeowners Use Pumping Vouchers**

"Get Pumped" septic tank workshops gave Shelby and Chilton County residents an opportunity to have their tanks pumped or onsite system repaired. To receive a \$250 service voucher, homeowners attended the one-hour workshop on how to maintain their systems. The money is part of a \$75,000 grant to improve water quality in a creek and surrounding watershed.

Participating service providers were not asked to limit fees, but most accepted the vouchers as full payment for a pump-out. The Calera Waste Treatment Plant supported the program by processing the septage.

## **INDIANA: Scholarship Winner Plans Wastewater Career**

Joseph Craven, a graduate of Rushville Consolidated High School, won the 2010-2011 Indiana Onsite Waste Water Professionals Association scholarship. He is attending Indiana University-Purdue University Indianapolis and plans to start his own business managing or designing wastewater treatment products. Craven has worked with his father, Richard Craven, of McCreary Concrete Products in Rushville since he was 14.

## **OREGON: Tank Seterioration Update Given**

The Oregon Onsite Wastewater Association newsletter had a follow-up article on septic tank deterioration. Robb Barnes of Kings Pumping in Dallas wrote that once the scum layer is formed, the only way out for gasses is through the top of the baffles. That is why deterioration concentrates on the corner of the lid directly above the outlet baffle top.

His installers carry glue in test caps that they lay on top of the 4-inch PVC or ABS outlet baffles. "We don't glue them in to retain access

to the outlet line should it require jetting, but we hope to stop gases from escaping to the top of the tank," he says. "When we install a replacement baffle with the Polylok drive-in insert, we also install a gas baffle at the bottom of the replacement baffle." Read the entire letter and view the illustrations at [www.o2wa.org/pages/news.php](http://www.o2wa.org/pages/news.php).

## **TEXAS: Fewer Aerobic Systems Showing Chlorine**

Reports from Texas Onsite Wastewater Association maintenance providers to the Brazos County Health Department showed that almost 40 percent of the area's 6,000 aerobic onsite systems had no chlorine in the recycled irrigation water. That number is up 20 percent from two years ago. Technicians check the chlorine level discharging through the sprinklers three times per year.

## **MISSOURI: New Instructions Given For Pharmaceutical Disposal**

Janet Murray, president of the Missouri Smallflows Organization, states in the group's newsletter that people can properly dispose of pharmaceuticals at home if communities have no drop-off points. Simply empty the medications into a plastic container such as a coffee can, add 12 ounces of Coca-Cola, and allow the acid in the soda to dissolve the capsules for an hour or more. Once everything is well dissolved, add coffee grounds or cat litter to absorb the moisture. Screw the lid onto the container and seal it with duct tape. Place the can in the garbage on collection day.

## *Training* & Education

### **NESC Publications**

National Environmental Services Center publications *On Tap*, *Small Flows* and *Pipeline* are available only in PDF format at [www.nesc.wvu.edu](http://www.nesc.wvu.edu). To receive postings of new issues, sign up at [www.nesc.wvu.edu/listserv/cfm](http://www.nesc.wvu.edu/listserv/cfm).

### **NAWT**

The National Association of Wastewater Transporters has these sessions:

- Nov. 11-12 – Operation and Maintenance, Mill Valley, Calif.
- Dec. 2-3 – Installer Training, Sonora, Calif.

Call Kit Rosefield at 530/513-6658 or visit [www.cowa.org](http://www.cowa.org).

### **Alabama**

Licensing classes are the joint effort of the Alabama Onsite Wastewater Association and University of West Alabama. Courses are at UWA Livingston campus:

- Nov. 10-12 – Basic Installer
- Dec. 2-3 – Continuing Education
- Dec. 8-10 – Advanced Installer Level II

The first day of continuing education classes is for installers and the second day is for pumpers and portable restroom operators. Call 334/396-3434 or visit <http://aowatc.uwa.edu>.

### **Arizona**

The Arizona Onsite Wastewater Recycling Association has these classes:

- Nov. 1-2 – Intro to Design of Onsite Wastewater Treatment Systems, Tucson
- Nov. 3-4 – Advanced Design of Onsite Wastewater Treatment Systems, Tucson



## Calendar

### Oct. 18-20

North Carolina Annual Onsite Water Conference, Jane S. McKimmon Center, Raleigh. Call Joni Tanner at 919/513-1678 or visit [www.soil.ncsu.edu](http://www.soil.ncsu.edu).

### Oct. 19-20

Delaware Onsite Wastewater Recycling Association Conference, Dover Downs Hotel and Casino, Dover. Call Jim Williams at 302/492-3915 or visit [www.dowra.org](http://www.dowra.org).

### Oct. 21-24

Ontario Association of Sewage Industry Services Conference and Expo, Great Wolf Lodge, Niagara Falls. Call 877/202-0082 or visit <http://oasisontario.on.ca>.

### Oct. 25-27

National Onsite Wastewater Recycling Association Technical Conference and Exposition, St. Louis, Mo. Call 800/966-2942 or visit [www.nowra.org](http://www.nowra.org).

Call Kitt Farrell-Poe at 520/621-7221 or e-mail [kittfp@ag.arizona.edu](mailto:kittfp@ag.arizona.edu).

## Iowa

The Iowa Onsite Waste Water Association has the CIOWTS Installation Overview and NEHA credentialing exam on Nov. 19-20 in Prairie City. E-mail Alice Vinsand at [execdir@iowwa.com](mailto:execdir@iowwa.com) or visit [www.iowwa.com](http://www.iowwa.com).

## Missouri

The Missouri Smallflows Organization is offering these CEU courses:

- Nov. 9-10 – High-Strength Waste, Branson
  - Nov. 16 – Selling System to the Site, Camdenton
  - Nov. 17 – Profitable Business, Camdenton
  - Dec. 7 – Selling System to the Site, St. Clair
  - Dec. 8 – Profitable Business, St. Clair
  - Dec. 14 – Pumps, Panels, and Electrical, El Dorado Springs
  - Dec. 15 – Drainfields and Water Management, El Dorado Springs
- Call Tammy Yelden at 417/739-4100 or visit [www.mosmallflows.org](http://www.mosmallflows.org).

## New England

The New England Onsite Wastewater Training Center at the University of Rhode Island in Kingston has these workshops:

- Nov. 4 – Rhode Island Designer Examination Preparation
  - Nov. 18 – AutoCALCS: Automated Bottomless Sand Filter Sizing, Pump Calcs, and Support Material
  - Dec. 2 – Rhode Island Regulatory Setbacks and Buffers
  - Dec. 9 – Nitrogen in the Environment and Onsite Wastewater Systems
  - Dec. 14 – Designing Nitrogen Removal Technologies
- Call 401/874-5950 or visit [www.uri.edu/ce/wq](http://www.uri.edu/ce/wq).

## North Carolina

The North Carolina Pumper Group and Portable Toilet Group are holding the mandatory annual four-hour septage management training seminar on Dec. 11 in Raleigh. The session includes land application site operator training. Call Joe McClees at 252/249-1097 or visit [www.ncpumpergroup.org](http://www.ncpumpergroup.org) or [www.ncportabletoiletgroup.org](http://www.ncportabletoiletgroup.org).

The North Carolina Septic Tank Association is offering the Installers and Inspectors course on Nov. 11-12 in Hickory. Call 336/416-3564 or visit [www.ncsta.net](http://www.ncsta.net).

Pumper invites your state association to post notices and news items in this column. Send contributions to [editor@pumper.com](mailto:editor@pumper.com). ■

# 500 SYSTEMS SAVED THIS YEAR...SO FAR!

THAT'S RIGHT, SINCE WE INTRODUCED AFTERSHOCK  
BIOREMEDIATION RESTORATIVE AT THE 2009 PUMPER  
& CLEANER ENVIRONMENTAL EXPO IN LOUISVILLE,

## 500 SYSTEMS HAVE BEEN RESTORED

BY THE OXYGEN-ENHANCED  
BACTERIA IN AFTERSHOCK,

### SINGLE DAY BIOREMEDIATION PROCESS!

Unlike all other oxidizing products, **AfterShock's** consortium of bacteria and oxidizer can be applied **at the same time**. The oxygen-accelerated bacterial action will quickly digest the organic solid materials that reduce the drain field's capacity to absorb water, effectively restoring drainage through a natural process. The bacteria contained in **AfterShock** are authorized by the USDA, and have been treating septic systems around the world since 1976.



To learn more about this revolutionary approach to restoring drainage as well as our entire line of state-of-the-art products for residential and commercial septic system treatment, grease waste systems, and for bioremediation, please call us toll-free at 1-800-759-2257 to request our product information package. Or log on to [www.SepticOnline.com](http://www.SepticOnline.com). There is no cost or obligation, and no obnoxious salesman will call you (a big plus with us).

If you've waited to get involved with bioremediation because the process is so tedious and time-consuming, now is the time to start. Do it all in ONE TREATMENT. Please call today. Thank you.  
– Rick Howe, President

GREEN PRODUCTS FOR SEPTIC PROFESSIONALS SINCE 1976

CAPE COD BIOCHEMICAL COMPANY

P.O. Box 990 • Pocasset, MA 02559



1-800-759-CCLS  
(1-800-759-2257)

FAX: 508-564-9974 • [www.SepticOnline.com](http://www.SepticOnline.com)

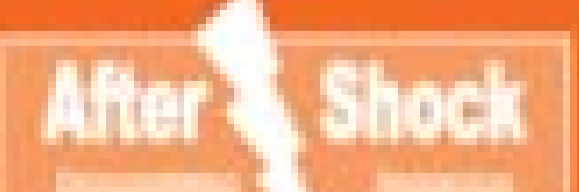



Discounted Portable Restroom Parts and Supplies

Liquid Waste Industries Has Low Prices on  
**EVERYTHING YOU NEED!**

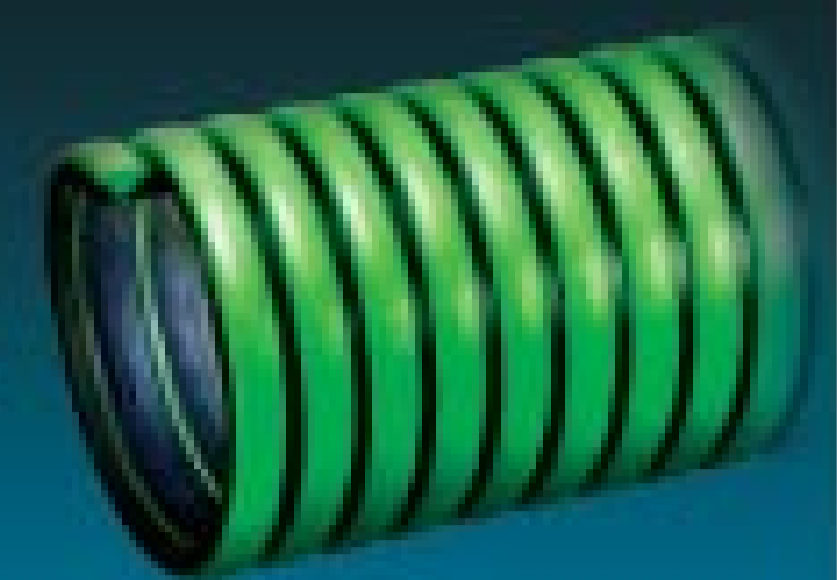

**CALL 877-445-5511** Visit Us Online  
[www.lwiinc.com](http://www.lwiinc.com)

## Atlantic Dewatering Services LLC

**DEWATERING**

**COMPOSTING**

**STAINLESS  
STEEL**

Financing  
available.



**Dewatering Trailer & CCS Composters**

Want a solution which will turn grease and septage into an unregulated product that can be sold?

All our dewatering equipment is available as either a "roll-off" or trailer platform, and our composting equipment is based on a "roll-off" platform. Our dewatering and composting systems offer a complete solution that is portable and easy to install at any site. We also offer a range of pumps and polymer systems.

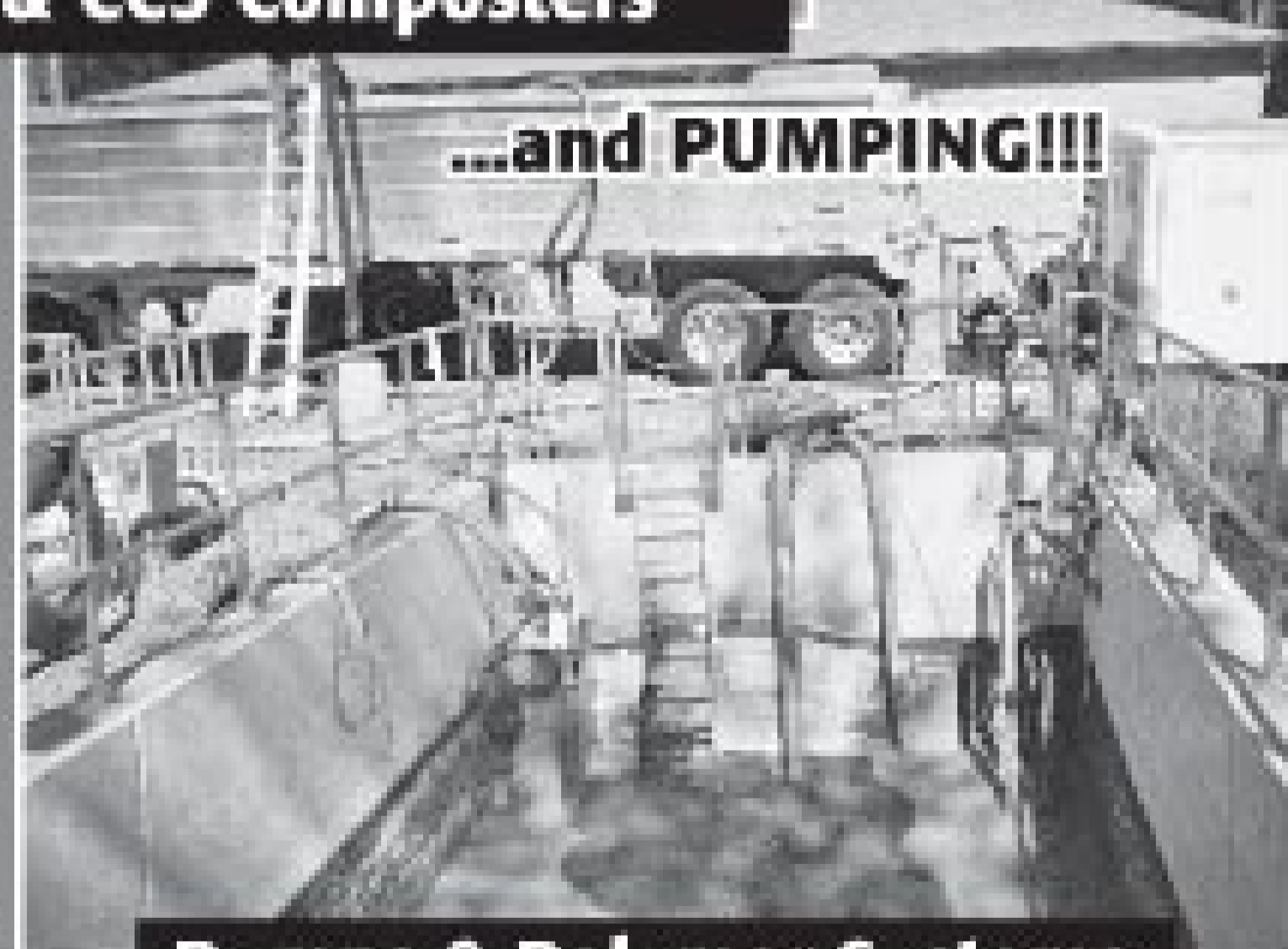

**Pumps & Polymer Systems**

For more information please call

**John 860 677 2300**

**Joe 910 990 2926**

Visit us on the web

[WWW.ATLANTICDEWATERING.COM](http://WWW.ATLANTICDEWATERING.COM)



### 12 VOLT DC HIGH HEAD WASHDOWN PUMP

- 1 HP Washdown Duty Motor for Severe Operating Conditions
- Investment Cast 316 Stainless Steel, Cast Iron or Cast Bronze Construction
- All Models Equipped With High Efficiency Stainless Steel Impeller
- Discharge Port Rotates in 90° Increments
- Four Front Drain Plugs
- Maximum Flow 56 GPM
- Maximum Head 80 Ft. (35 PSI)
- Maximum Temperature 200° F



The AMT 12 Volt DC Washdown Pumps are designed for pumper, septic service, OEM, and marine applications requiring a DC motor. The motor has a one hour duty rating and is furnished with a grade 303 stainless steel shaft. Washdown Duty Pumps are available in a variety of construction and seal materials to meet your specifications. Pull-from-the-rear design for easy servicing without disturbing piping.

**Call us toll free at 888-268-7867 or visit our website  
[www.amtpump.com](http://www.amtpump.com) for more information.**

American Machine & Tool  
A Subsidiary of The Gorman-Rupp Company  
400 Spring Street  
Royersford, PA 19468



# THE "ORIGINAL" LIQUID SMOKE



**Solutions for:**

- Infiltration
- Tracing
- Illicit Connections
- Leaks and more...



M45

[www.turbo-fog.com](http://www.turbo-fog.com) TOLL FREE 1-800-394-0678

## Mobile Dewatering Service



**Municipal & Industrial Sludge Digesters, Lagoons, Ponds, etc.**

- Double Belt Filter Press
- Up to 25% Drier Cake
- Professionally Staffed
- US & Canada

**Fluid Technology, Inc.**

P.O. Box 937, Oxford, OH 45056  
Phone: 513-421-1600  
E-mail: [sales@fluidtechinc.net](mailto:sales@fluidtechinc.net)  
Web site: [www.fluidtechinc.net](http://www.fluidtechinc.net)

## Waterblaster Rentals & Sales

Houston, Texas



**Boatman Industries**

1K to 50K psi  
60 hp to 1000 hp  
Waterblasters & Accessories  
Used Equipment Sales

**713-641-6006**  
[www.boatmanind.com](http://www.boatmanind.com)



**Poly-Triplex® Liner System**  
Cured-in-Place  
Structural Rehabilitation



Up to 20 YEAR  
WARRANTY from the  
Manufacturer to stop  
infiltration, chemical  
corrosion & deterioration.

For Permanent Rehabilitation of  
**MANHOLES \_ PUMP  
STATIONS  
CATCH BASINS \_  
CULVERTS**

For information on the process or  
how to become a Certified Installer,  
please contact:

**850.547.9999**  
[www.poly-triplex.com](http://www.poly-triplex.com)

# Pumper Marketplace Advertising

## THE SHADDIX COMPANY



4-1000 gal.  
Rebuilt Septic  
Tank forms  
**\$7,000 Ea**

FOB Cullman, Alabama

2001 FL 70  
Freightliner  
Low mileage  
**\$35,000**



2002 Non-  
CDL **\$33,000** Both equipped with  
almost new hydraulic set beds

Will build forms to your specifications.

We build hydraulic set beds.

**256-338-4987 or  
256-737-0051**

## T&T Tools, Inc. 800.521.6893



**CALL for a FREE Catalog**

Many styles Available

Insulated  
Soil Probes  
(for locating)

Heat-Treated  
Hooks  
(for covers, lids, etc)

[www.mightyprobe.com](http://www.mightyprobe.com)



DO YOU HAVE SOMETHING TO HIDE?™



**NEW FROM DEKORRA PRODUCTS**

108 Rock to conceal up to 24" diameter plastic septic lids and risers at grade

107 Rock to conceal up to 23" tall septic vent stacks and well casings.

[dekorraproducts.com](http://dekorraproducts.com) | 888.635.8585



**NEW Drainfield Soil Restorative works on the soil NOT THE TANK!**



- » Easy to apply
- » Restores soil failed drain fields
- » Improves perkability

**RCS II, Inc.**  
**518.812.0000**  
[www.septicdrainer.com](http://www.septicdrainer.com)

# DECALS

**FREE SHIPPING**

ON ALL ORDERS WITHIN CONTINENTAL U.S. when you mention this ad

**CALL Us TODAY!**  
**800.829-3021**

- Portable Toilet
- High Tack Decals
- Service Records
- Fleet Graphics
- Equipment Decals
- Lack of Service Tags

**LOW COST  
HIGH QUALITY  
FAST  
TURNAROUND**

**ScreenTech**  
IMAGING  
a division of Roadie Signs, Inc.  
email: [debbie@screeentech.com](mailto:debbie@screeentech.com)  
[www.screeentech.com](http://www.screeentech.com)



We're  
Everywhere  
You Are.

**Pumper.com**



Have you  
seen the  
**onsite installer  
E-Zine?**

Go to [onsiteinstaller.com](http://onsiteinstaller.com)  
to view the e-zine.

[www.PumperTruckMagnets.com](http://www.PumperTruckMagnets.com)  
**1-800-758-2743**

**TCF**  
 EQUIPMENT FINANCE

Experts at Delivering  
 Equipment Finance Solutions

- A general equipment finance company
- Providing a broad range of financing options nationwide for the Environmental Services industry
- Industry expertise allows us to tailor your financing or leasing structure to match your cash flow requirements

Contact:  
**Wendy Wilson** | **Jeanice Jenkins**  
[wwilson@tcfef.com](mailto:wwilson@tcfef.com) | [jjenkins@tcfef.com](mailto:jjenkins@tcfef.com)  
 Ph 317.328.1161 | Fax 317.328.1175  
[www.tcfef.com](http://www.tcfef.com)

**DYNAMIC  
 CABLE REPAIR**

We Repair: General Wire, Rotech, RIDGID, Aries, Insight Vision, Electric Eel, GatorCams, Plumbers Depot, UEMSI, Pearpoint, Spartan, Vision Intruders, Vivax, Inspection Cameras, Locators, Command Modules and Cables

**48-Hr. Turn  
 Around  
 Time**  
**INSPECTION CAMERAS  
 ARE OUR  
 ONLY BUSINESS!**

**973-478-0893**  
**DYNAMIC REPAIRS**  
 40 Arnot St., Unit 20 • Lodi, NJ 07644  
[www.dynamicrepairs.net](http://www.dynamicrepairs.net)

**EASILY MOVE RESTROOMS  
 with  
 Super Mongo Mover®**

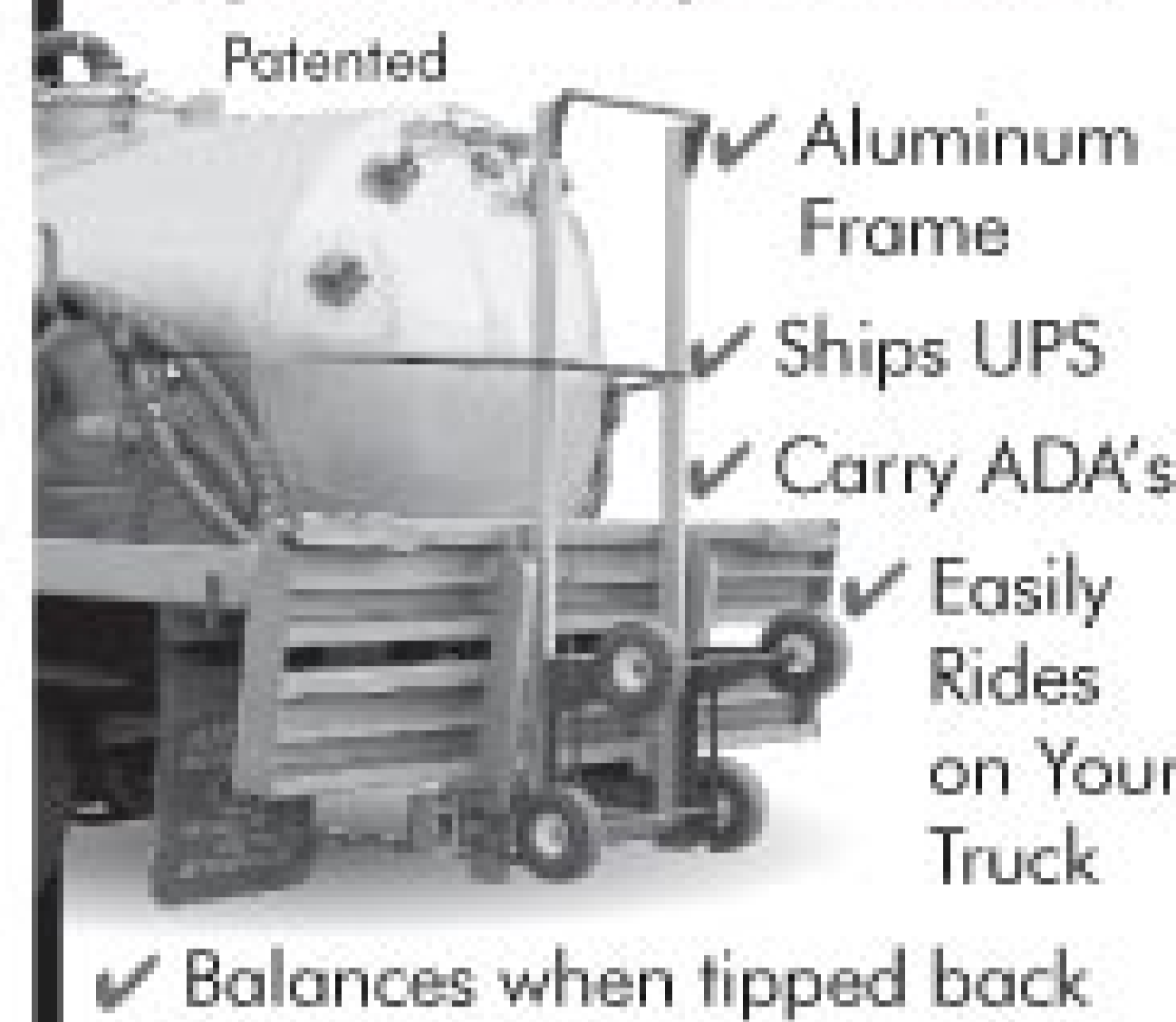

Patented

- ✓ Aluminum Frame
- ✓ Ships UPS
- ✓ Carry ADA's
- ✓ Easily Rides on Your Truck

✓ Balances when tipped back  
 Available with 2, 4, 6 or even 8 wheels and your choice of air or solid foam tires.

**DA** [www.dealassoc.com](http://www.dealassoc.com)  
 Deal Assoc. Inc. **866.599.3325**

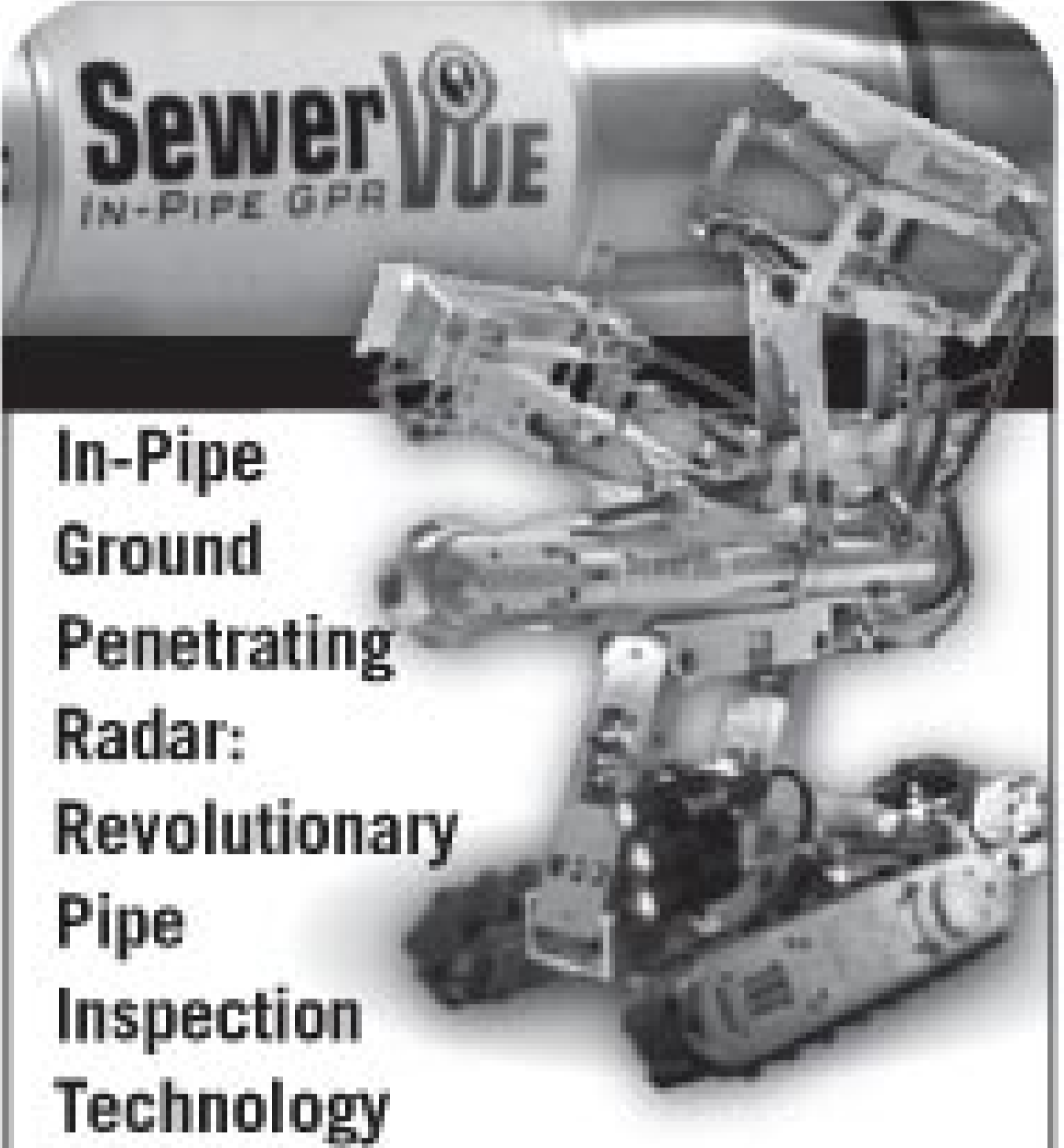

**In-Pipe  
 Ground  
 Penetrating  
 Radar:  
 Revolutionary  
 Pipe  
 Inspection  
 Technology**  
 Accurately measures pipe wall thickness, rebar cover & detects voids within our outside large diameter concrete pipes  
 Prevents catastrophic failures using in-pipe manned entry & proprietary robotic inspection  
 Reliable information about the condition of critical infrastructure & remaining service life of underground pipes  
[info@sewervue.com](mailto:info@sewervue.com) [www.sewervue.com](http://www.sewervue.com)  
**1.888.9 SEWERVUE**  
 1.888.973.9378



**SOLUTION for  
 TRAP WASTE**

Consists of a 10,000 gal. tank with boiler burning 100% brown grease as fuel resulting in brown grease recovered and sold as a commodity.  
 Patent Pending

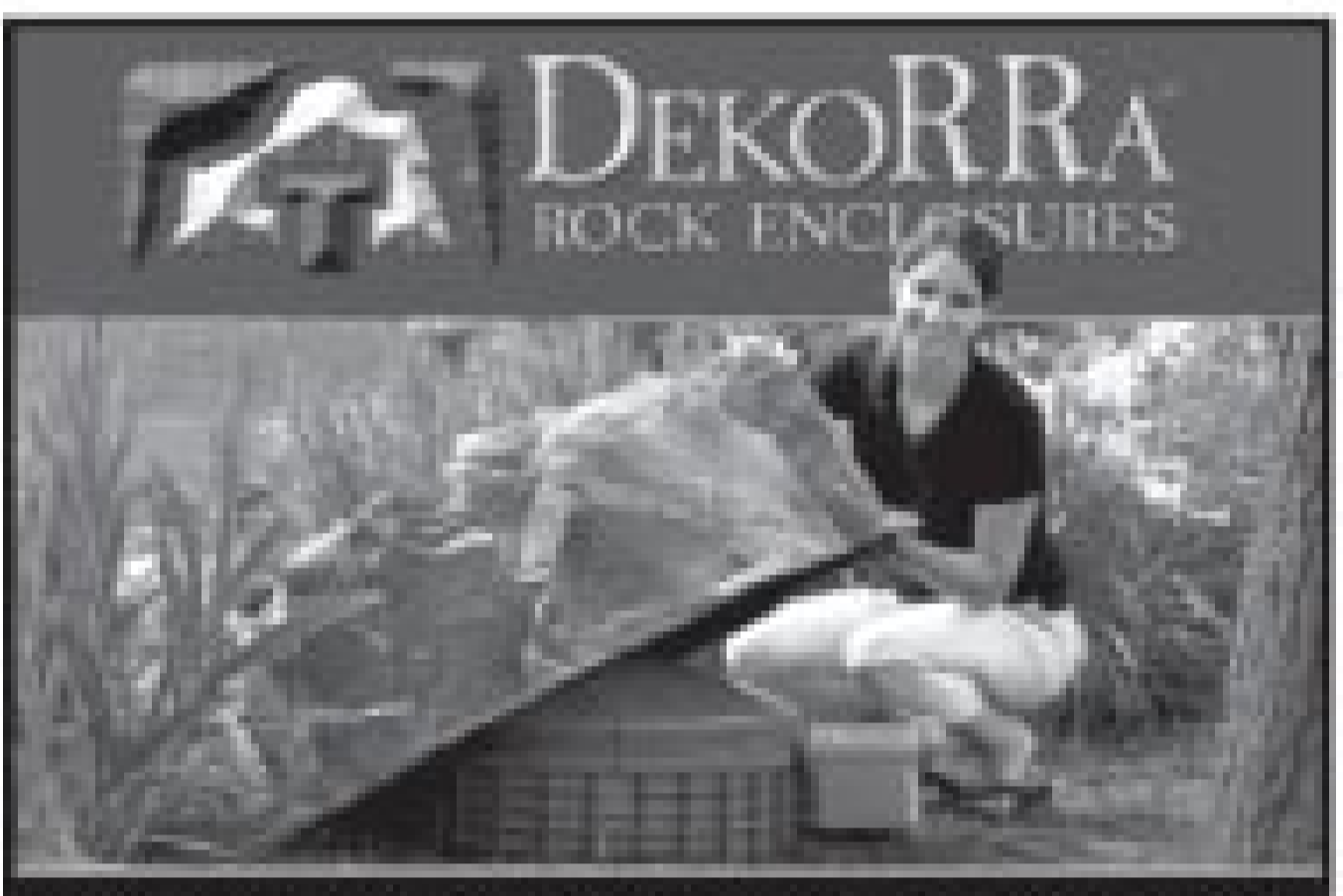

**DO YOU HAVE SOMETHING TO HIDE?™**  
 We're excited to present top-quality rock enclosures made with an all new textured material, RealRock™. This gritty, tough, and variegated rock-like surface is astonishingly realistic—you truly have to see it to believe it.  
 • Several models cover large septic risers—even those with junction boxes  
 • Upgraded commercial construction  
 • New shapes and sizes  
 • Smaller models cover cleanouts and vents  
**DEKORRA**  
 PRODUCTS LLC 888-635-8585  
[www.dekorraproducts.com](http://www.dekorraproducts.com)

**DYE TRACERS**  
 Solutions for:  
 • Infiltration  
 • Septic Systems  
 • Cross Connection  
 • Leaks and more...  
**BRIGHT  
 DYES**  
 Division of Kingscote Chemicals  
[www.brightdyes.com](http://www.brightdyes.com) FREE SAMPLE 1-800-394-0678

**CONFINED  
 SPACE  
 ENTRY  
 PACKAGE**  
**ONLY \$2,995**  
**The best package on the market includes:**  
 • 4-Gas Air Monitor (3 Year Sensor Warranty)  
 • 7' Tripod  
 • 3-Way Fall Protection  
 • Work Winch  
 • Full Body Harness  
 Add a Blower with 15' of duct for only \$350!  
 Add a 5 Minute Escape Respirator for only \$500!  
**MTECH** 800.362.0240  
[www.mtechcompany.com](http://www.mtechcompany.com)

1/4" closed cell gasket seals tight.  
 Ships with 2" stainless steel fasteners.  
**Romotech**  
 Romotech is a custom molder. See us for your new project. 574.831.6450 [www.romotek.com](http://www.romotek.com)  
 • Long lasting durability  
 • On-site installation flexibility  
 • Custom logo option  
 • 15", 18" and 24" sizes designed to fit standard pipes  
 Optional tank adapter accommodates supplied secondary cover

**EQUIPMENT  
 FINANCING**  
 New & Used Equipment  
**\$5,000 - \$50,000**  
**FP**  
 Kirstin Elmer, CLP  
 877-332-9861  
**FINANCIAL PACIFIC  
 LEASING**  
 Since 1975

**It's A  
 BOGGY  
 FULL!**  
**Pumper**  
**pumper.com**  
 > Classifieds  
 > Truck Stop Ads  
 > E-zines  
 > Product Categories

Wolverine Brand  
The Best Septic Vent  
Filter Money Can Buy

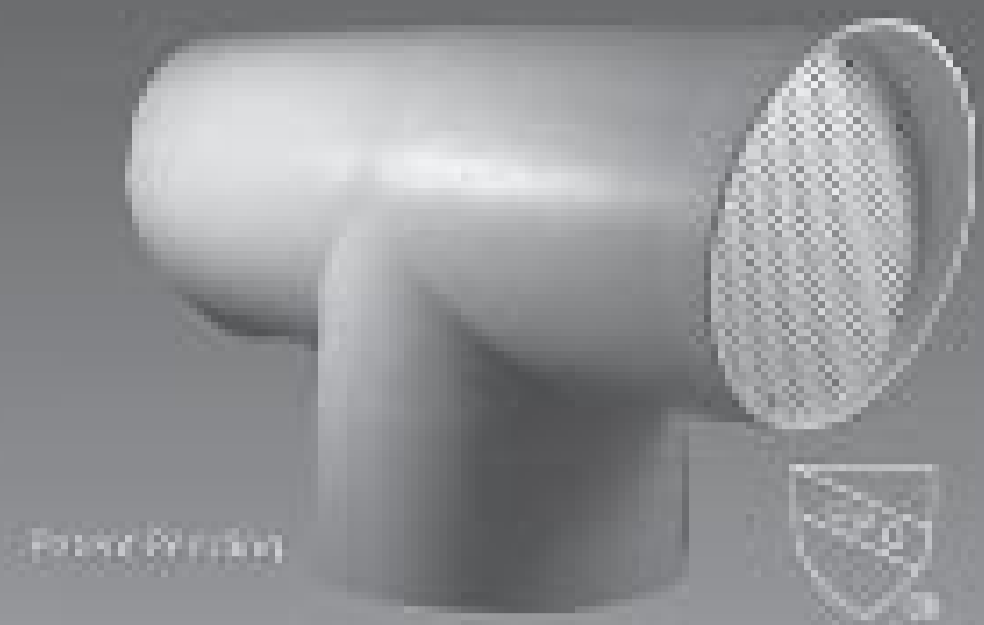

- More Carbon than other filters
- Patented Cross Flow Design Wicks Away Moisture

IndustrialOdorControl.com

866-NO-STINK (667-8465)  
973-846-7817

Simple Solutions  
DISTRIBUTING LLC



## Aluminum Vacuum Tanks

ALUMATANK

progresstank.com

PORTAVAC

## Septic & Restroom Service

WWW.ROOTERMAN.COM



Franchises available with low, flat fee  
New concept. Call 1-800-700-8062.

FRANCHISE PACKAGE \$7,950.

## BioOne®

Biological Maintenance for  
Drain Lines, Grease Traps  
and Septic Systems

- INCREASE PROFITS 20%
- EASY TO SELL
- SIMPLE TO USE
- PROFESSIONAL STRENGTH
- EPA RECOGNIZED

You have everything to  
gain...call 800-951-4246  
for your FREE sample.

One Biotechnology  
www.1biotechnology.com



## WATER JETS FOR RENT



- Units from 4,000 to 40,000 psi, including convertibles
- 60-600 hp, diesel or electric
- Rent, buy or lease
- Branches in MI, TX, NJ, CA, LA

NLB Corp. 1-877-NLB-7996  
www.nlbcorp.com

## FIND LEAKS and Sources of Odor

Quick • Inexpensive • Easy

with the

Superior® 5E



## Electric Smoker

Using Superior® Classic Smoke

1-800-945-TEST

www.SuperiorSignal.com

The Most Durable & Economical  
**Septic Lid**  
Durable & Lightweight Polymer  
WILL NOT Crack Like Concrete!  
Easier to Handle & Transport  
12", 18" & 24" Available  
Easy Installation  
Optional Sand Filled

Lowest Price  
15" & 24"  
Custom Lid

Cost Effective  
6 Pack  
Shipping

800.868.0973

## DISCOUNT ALUMINUM

SHEET,  
COIL,  
PLATE

3003/5052/  
5454/5083/5086  
AND MORE

20 MILLION  
POUND INVENTORY

ARE YOU PAYING  
TOO MUCH?

1-888-540-0066

ASK FOR DAN

FAX:  
440-286-2229

E-MAIL:  
captaluminum@msn.com

## BÖRGER®

Customized pumping  
solutions for your toughest  
liquid waste application!



The Multichopper  
Single Shaft Grinder



The Multicrusher  
Twin Shaft Grinder

Visit us at booth 3243  
at WEFTEC 2010

877.726.3743  
www.boerger-pumps.com

Rotary Lobe Pumps  
Macerating Technology

## Welcome to Bio-Microbicsville

...a growing community built on better ideas

Proven wastewater & storm  
water treatment systems

For more information, visit

www.biomicrobics.com,  
or call 800-753-FAST(3278)

BIO-MICROBICS  
INCORPORATED

Better Water. Better World.™

© 2009 Bio-Microbics, Inc.  
8450 Cole Pkwy • Shawnee, KS 66227, USA  
phone: 913-422-0707 • fax: 913-422-0808  
www.biomicrobics.com • sales@biomicrobics.com

## Anchor Graphics, Inc. Labels & More

- Service Records
- Portable Toilet Signs
- Logo Signs
- Signs (Plastic & Aluminum)
- Gender Signs

All types of custom printing  
and sizes available!  
Check out our great prices!

We Specialize in Waste  
Management Labeling Solutions

April is our magnet  
special month!  
Call for free offers!!!

Best Value in  
the Industry!

10015 Rearwin Lane McKinney, TX 75071  
sales@anchorgraphics.com  
Phone: 972-422-4300 Fax: 972-422-4311  
(800)875-7859 www.AnchorGraphics.com

# Pumper see photos in COLOR at [www.pumper.com](http://www.pumper.com)

# TRUCK STOP



October



**2000 International 530 Septic Truck:** 100% new tires, auto trans., 4000 gal. tank, 400XL Masport pump, rear air tag axle, 145,000 miles, one owner. Nice!  
.....\$60,000  
**517-719-2869** P10



**2004 Isuzu Work Mate:** 650 waste, 300 fresh, Masport DC pump, 4-place toilet carrier with lift. Excellent condition, ready to work. Part trade for slide-in unit. West Coast.....\$23,500  
**360-414-8161** P10



**2005 F450:** 8-month-old Abernethy unit, 500/200, good rubber, nice truck, cold air. ....\$27,500 Firm  
**304-416-3238 WV** P10



**1999 International 4900:** Keith Huber unit, 2200/300, rebuilt engine less than 1,000 miles, with jetter and hydraulic dump. Excellent condition.....\$39,500  
**251-479-2221 AL** P10



**1985 Mack MR:** 3400 gal. tank, 100 gal. fresh water, full hoist, full opening rear door, good tires and brakes, all hoses included, ready to work. Extra new PB 8 pump included (\$4,000 value). \$22,000  
**630-562-2288** P10



**1999 Freightliner FL70:** 33,000 GVW, 7-spd., toilet carrier, Moro M10 pump, 1000 waste/450 fresh.....\$21,500  
**Mike @ 303-478-4796**  
**or JR @ 720-253-8014**  
[www.pumpertrucksales.com](http://www.pumpertrucksales.com) P8M



**2005 Ford F550 Super Duty Diesel Flatbed:** 8-unit stainless steel bed, white/grey, automatic trans., low miles. ....\$21,000  
**1-800-634-2085 NY** P10



**1999 Freightliner 120:** 18-spd., Cat 3406E, 600 hp, 3-stage Jake, new 3600 gal. tank, new R260 Jurop hydraulic drive pump. Delivery available in the USA. ....\$45,000  
**For more info:**  
[www.JEagleTanks.com](http://www.JEagleTanks.com)  
**or call Jerry at 800-721-2774**  
**or 239-656-2774** P10



**2003 Ford F550:** 2WD, auto, Satellite 600 waste/300 fresh, Conde pump, 6L diesel, fresh water pump, portable toilet carrier. Used in daily operation. 250K miles.....\$17,000  
**417-623-4818** P10



**2001 International 4900 DT 466:** 280 hp, 9-spd. trans., Hendrickson susp., 3600 gal. tank with Jurop R260 vac pump, 4" load line, 6" discharge, built in 2008. ....\$45,000  
**318-349-9106 LA** P10



**2005 Sterling L70 Vector/Combo:** Good condition, 37,615 miles.  
.....Asking \$135,000 OBO  
**Please email**  
[skozlowski@nationalvacuum.com](mailto:skozlowski@nationalvacuum.com) P10



**1987 GMC C70:** 2200 gal. tank, 383 gas with 6000 miles, 5+2, air brakes, PTO driven Jurop PN 58, 230 cfm vacuum/pressure. ....\$17,000  
**Mike 435-225-3333 Utah** P10



**2001 Kenworth T300 Cat:** 8-spd., heated valves, Masport pump, new Pik Rite tank, 2300 gal. Durabrite rims, 145,000 miles. ....Asking \$56,000  
**518-774-4960** P11



**2001 International 267 Vector Combo Jetter:** Good condition, 9036 hrs./50,861 miles. ....Asking \$85,000 OBO  
**Please email**  
[skozlowski@nationalvacuum.com](mailto:skozlowski@nationalvacuum.com) P10



**2003 Mack CH:** E-7 330 hp, 10-spd., low miles, new 4000 gal. tank, new Jurop LC420, new accessories, aluminum wheels, ready to go! .....\$65,000  
[www.nationaltruckcenter.com](http://www.nationaltruckcenter.com)  
**Office: 305-691-8407**  
**Michael Vera: 786-554-0892**  
**George Gonzalez: 954-558-0816** P10



**1997 Camel MCB on GMC C8500:** 10-yd. debris body, 500 gallon water tank, hydraulic extendable boom, catch basin gun with reel, Cat 3116 250 hp diesel engine, tandem axle. (Stk. 1659)  
**Call Joe Donlon @ 312-208-6373** P10

# Pumper see photos in COLOR at [www.pumper.com](http://www.pumper.com)

# TRUCK STOP



*October*



**1993 International 9200:** 3500 gal. tank. Truck is in good condition, ready to work. ....\$16,900  
**Joey @ 205-631-8073**  
**or 205-789-9736 AL** P10



**Brand New 2007 Sterling 360:** 3-yr. unlimited mile warranty, new Robinson alum. tank, 600 waste/300 water, liftgate, Conde pump, w/washdown unit. \$49,500  
**Mike @ 303-478-4796**  
**or JR @ 720-253-8014**  
**[www.pumpertrucksales.com](http://www.pumpertrucksales.com)** PBM



**1999 Freightliner FL70:** Non-CDL, 2000 gal. vacuum tank and Jurop MN84 - new in 2008. Very good condition. ..\$29,000  
**703-424-8126 or 703-239-2011** P10



**2000 Freightliner FL70:** 6-spd. trans., air brakes, 300K miles, 2100 gal. tank, AC, working daily, Cummins diesel, Moro pump, alum. diamond plate tool box. ....Was \$34,000 - Now \$24,000  
**269-362-2588** P10



**1999 Kenworth T300 Pumper Truck:** New aluminum 2700 gal. tank, tires and pump in 2007. 327,423 miles, 6-spd., EXCELLENT condition. ....\$42,000 OBO  
**352-249-7289** P10



**STETCO BASIN CLEANERS:** 4 in stock, from city. They run and operate. ....\$8,900 to \$13,900 (\$8,900 has no clam shell)  
**Opdyke Truck Sales**  
**800-520-4704** PBM



**2007 Peterbilt 340:** Presvac 3600 gal. alum. vacuum tank, Masport HXL400WV pump pkg. + 3 heat jackets, built by Vacuum Sales, 14,086 miles. Current price new \$142,560.....Asking Only \$115,000  
**Norm 586-604-2034 MI** P10



**2006 Peterbilt 379:** Cat C-15 475 hp, Jake brake, 13-spd., new 5000 gal. tank, new Jurop LC420 pump, 20K tag axle, alum. wheels. Call for more info. ....\$112,000  
**[www.nationaltruckcenter.com](http://www.nationaltruckcenter.com)**  
**Office: 305-691-8407**  
**Michael Vera: 786-554-0892**  
**George Gonzalez: 954-558-0816** P10



**1994 Ford L 8000:** 8.3 Cummins, automatic, 2500 gal. tank, rebuilt vac pump, 230,000 miles. ....\$12,900 OBO  
**716-942-3292 - NY** P10



**2004 Sterling:** 430 hp, 10-spd. trans., Jake, AC, cruise, new 3500 gal. tank and vac pump, new paint and tires. This is a beautiful truck. ....\$59,500  
**740-820-5520** P10



**2004 Ford F550:** 2WD, auto, Lely tank 700 waste/300 fresh, Masport pump, 6L diesel, dual side service, fresh water pump, portable toilet carrier. Used in daily operation. 190K miles. ....\$19,000  
**417-623-4818** P10



**2008 Ford F-550:** 6.4 diesel, 325 hp, auto trans., 120K miles, 2-yr. warranty on new motor, 19K GVW, 950 waste/300 fresh, Masport HXL-4 pump, Chelsea PTO, 2-toilet rack, 3' side dump, 30' 2" hose. ....\$42,500  
**Steve 618-922-2338 IL** P10



**2004 Vactor 2115 on International 7400 Chassis:** 15-yd. debris body, 1,300 gal. water, 80 gpm @ 2500 psi, 2-stage fan, accumulator, winter recirc., 8' telescopic boom, rotating hose reel. (Stk. 1652)  
**Call Joe Donlon @ 312-208-6373** P10



**1991 Freightliner:** 350 hp Cummins, 9-spd. trans., AC, 3500 gal. tank and Jurop R260 vac pump, less than 1 yr. old. Truck runs and works great; used every day. ....\$26,500  
**740-820-5520** P10



**2007 Peterbilt 379:** Cummins ISX 500 hp, 10-spd., Jake brake, certified 20K front axle, 20K tag axle, new 5000 gal. tank, new Jurop LC420 liquid-cooled pump. ....\$125,000  
**[www.nationaltruckcenter.com](http://www.nationaltruckcenter.com)**  
**Office: 305-691-8407**  
**Michael Vera: 786-554-0892**  
**George Gonzalez: 954-558-0816** P10



**1998 International 4700 W/466E:** Allison auto. trans., air brakes, A/C, new tires, batteries. Satellite 750 waste, 350 fresh w/dual cabinets and catwalk, Masport M2. Under CDL. Real nice condition. ....\$22,500  
**Mike @ 303-478-4796**  
**or JR @ 720-253-8014**  
**[www.pumpertrucksales.com](http://www.pumpertrucksales.com)** PBM

# Pumper see photos in COLOR at [www.pumper.com](http://www.pumper.com)

# TRUCK STOP



October



**2003 International 8100:** Cat C-10, 350 hp, 10-spd., 367K miles, new 4000 gal. US tank, new Juropl LC420 pump, new paint, all new accessories. ....\$59,000  
[www.nationaltruckcenter.com](http://www.nationaltruckcenter.com)  
**Office: 305-691-8407**  
**Michael Vera: 786-554-0892**  
**George Gonzalez: 954-558-0816** P10



**Vac-Con 1999 International 2554:** Auto, 59,238 miles, 8363 hrs., JD engine 2394 hrs., 8" 2-stage tele 10' boom, hyd. 3-stage comp., 80 gpm pump, 1300 water tank, 1" articulating hose reel, 12-yd. tank. NICE UNIT.....\$64,500  
**888-494-7688 - CA** P10



**1993 International 4900 DT 466:** 250 hp, 33,000 GVW, 6+1 trans, new motor 80,000 miles, 2,350 gallon tank, Juropl R260 pump, cab repainted, new tires. Great starter truck. ....\$35,000  
**770-898-3761 - Georgia** P11



**1999 Freightliner Century Class:** 3000 gal. tank, C-12 435 Cat motor, Eaton Fuller 13-spd., fresh paint, 3" intake vacuum port, 6" dump port, Masport pump, ready to work. ....\$33,000  
**541-672-8709 OR** P10



**1995 International 9200:** 3000 gal. tank, 10-spd., new clutch, good condition, used daily. ....\$17,900  
**Joey @ 205-631-8073**  
**or 205-789-9736 AL** P10



**2000 Freightliner FL70:** 33,000 GVW, 3126 Cat, 230 hp, 6-spd. Fuller trans., air, cruise, 140,023 miles, new 2300 gal. tank, new Juropl PN84 pump.....\$38,900  
**Central Wisconsin Body & Hoist Inc.**  
**Jason Wendell 877-355-2924** P11



**2003 Ford 550 with Satellite Tank:** Truck looks and runs great. New pump in 2010, new paint in 2009. 600 waste/300 fresh with washdown, 190,000 miles. ....\$17,000 OBO  
**315-247-0582 NY** P11



**2002 Freightliner FL-70:** 166K miles, new 2200 gal. US tank, new Juropl R260 pump (363 cfm), 1-year/100,000-mile engine warranty. ....\$43,000  
[www.nationaltruckcenter.com](http://www.nationaltruckcenter.com)  
**Office: 305-691-8407**  
**Michael Vera: 786-554-0892**  
**George Gonzalez: 954-558-0816** P10



**2000 International 4700:** 33,000 GVW, automatic, 1000 fresh/450 water, toilet carrier.....\$21,500  
**Mike @ 303-478-4796**  
**or JR @ 720-253-8014**  
[www.pumpertrucksales.com](http://www.pumpertrucksales.com) P8M



**2006 Peterbilt 379:** 442K miles, 5000 gal. heavy duty tank, new Juropl LC420 pump. This truck must be seen! Looks like new! Call for more info. ....\$112,000  
[www.nationaltruckcenter.com](http://www.nationaltruckcenter.com)  
**Office: 305-691-8407**  
**Michael Vera: 786-554-0892**  
**George Gonzalez: 954-558-0816** P10



**TWO FOR ONE SPECIAL!** 1991 Ford LN8000, 1986 Ford LN8000 Vactor jet rodder. Both need minor repairs. ....\$30,000  
**260-489-6021 IN** P11



**Brand New 30-Yard Dewatering Box:** .....\$24,000  
 Also have 20- and 40-yard boxes available.  
[www.dewateringofnewengland.com](http://www.dewateringofnewengland.com)  
**800-379-5977** P10



**2005 International DT466:** Automatic trans., Masport 400 pump, 2600 gallon tank, 11:00x22.5 rubber all 70%, 76,000 miles. Excellent condition, ready to go to work. ....\$59,000  
**Call Russ at 508-207-8524** P10



**1997 Freightliner Vacuum Truck:** 3500 gal. Transway tank, 277,000 miles, Cummins diesel engine, 8LL transmission. ....\$35,000 OBO  
**Diana Macken 716-912-0574 NY** P10



**Grit Grabber 750:** Catches the grit to keep it from entering into the Waste Water Treatment Plant or storage tanks. ....\$21,000  
**603-428-3351** P10



**2006 International 4200:** 64,000 miles, International 215 hp engine, Allison automatic 5-speed, 33,000 GVW, new Progress 2800 gal. aluminum tank with Juropl R260 pump. ....Asking \$55,000  
**318-349-9106 LA** P10



# When a Vac Truck Can't---*Hydra-Tech Pumps Can...*

**Get More Jobs** with Our Solids Handling Pumps

- Eliminate High Suction Lift Problems
- Use for Fast Loading and Unloading of Tank Trucks
- Truck Mounted or Stand-Alone Submersible Pump
- Hydraulic Drive - Your Power or Ours
- 3" and 4" Models with Flows to 900 GPM
- Rugged Cast Construction - Iron, AL & SS



See our full line at [www.hydra-tech.com](http://www.hydra-tech.com)

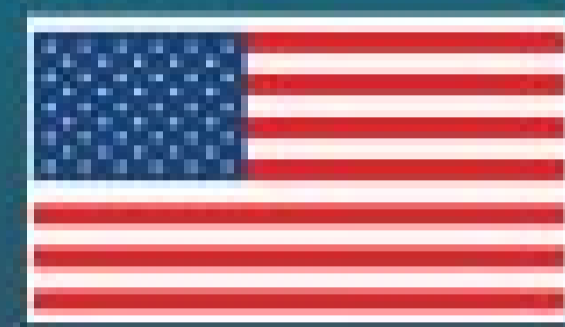
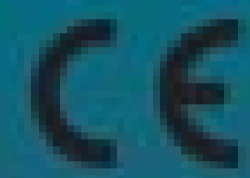

American Made



## HYDRA-TECH PUMPS

email: [htpump@hydra-tech.com](mailto:htpump@hydra-tech.com)

Stop and  
See us at



Booth Number  
**9303**

Mention this  
ad and receive **10% off** your first  
order!

**Septic Fizzytabs** CustomBio  
SEPTIC SYSTEM BACTERIA  
After You Pump,  
Sell A Years Supply Of Bacteria  
Contact for a FREE SAMPLE Info@custombio.us  
561-998-1699

## Clear Computing Software With GPS by StreetEagle

Paperless Operations  
Reduce Your Expenses



Lease or Buy – Call for Internet Demo

Clear Computing  
(888) 332-5327

[www.clearcomputing.com](http://www.clearcomputing.com)

Insight-USA  
301.866.1990 x205  
[www.mds-inc.com](http://www.mds-inc.com)

Our advertising over the years has always  
made mention of the fact that we *build* the  
**BEST VACUUM TRUCK  
IN AMERICA.**



We don't say that as a *cheap* advertising line.

We say it because we work *hard* on every truck and frankly we  
don't want to build the second best truck or the third best.  
Our goal and our results go one way: **The best.**  
We *don't* take shortcuts. We *care* about our customers. We *care* about  
our craftsmanship. We *believe* in customer service. Everyday we strive to  
do better than we did the day before. It's very likely true that there is  
one thing we are not: We are not the cheapest. When was the last  
time you heard that the *cheapest* anything turned out to be the best.

Call us. We build the  
**BEST VACUUM TRUCK IN AMERICA.**



Since 1937  
Glendale Welding Co.  
Glendale, Arizona

**623.937.7414**  
[glendalewelding.com](http://glendalewelding.com)

# Crystal Environmental

Specializing in Industrial & Municipal Solids-Liquids Separation since 1992.



## Patent Applied for **POLYWICK™ DEWATERING CONTAINERS**

- ◆ High Molecular Weight Polyethylene construction is lighter than steel.
- ◆ Water quality results are "Crystal" clear.
- ◆ Ideal for grease or lime stabilized solids – all wetted parts are pH resistant.
- ◆ Exceptional Service Before & After your purchase!



Designed and Manufactured by Bucks Fabricating. Bucks Fabricating and PolyWick are trademarks of Deist Industries, Inc.

Production models may differ from product shown.

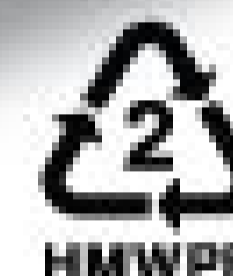

**1-814-434-0540**

**www.crystalenv.com • 1-800-328-9720**

# Septic-Scrub™

**Used by More Professional Pumpers to Increase Their Business**

Backed By Science ■ Proven with Experience ■ Many Satisfied Homeowners

Septic-Scrub™ is a superior product for the maintenance and restoration of septic system drainfields. Customers appreciate that it is environmentally safe, contains no organic chemicals and does not produce any toxic by-products. Most importantly, **Septic-Scrub works.** It breaks down sulfide buildup in the biomat and soil to allow for better water absorption.

Learn more about Septic-Scrub at [www.arcana.com](http://www.arcana.com).

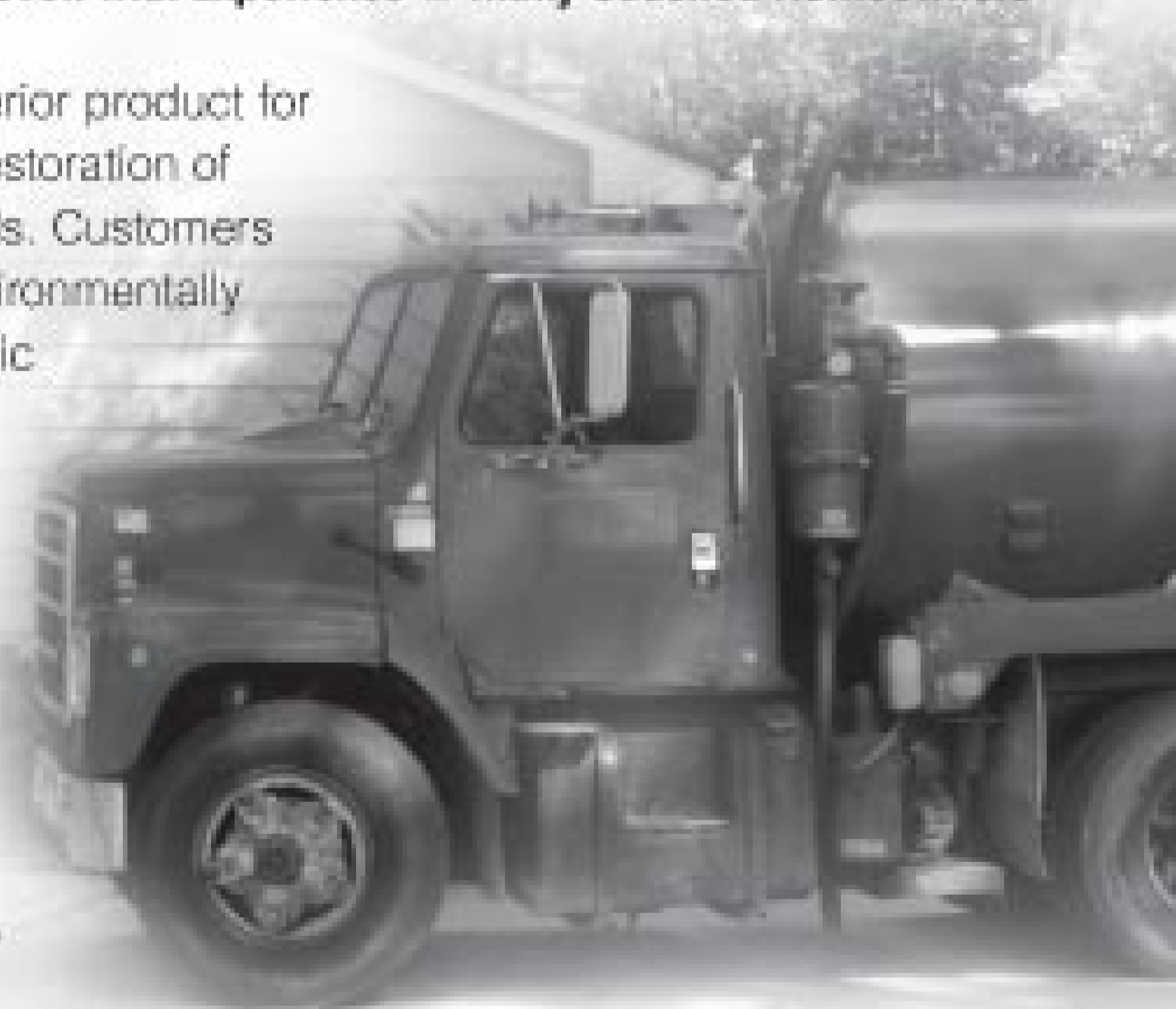

**arcana**

P.O. Box 31057  
Clarksville, TN 37040

For information on increasing sales and providing a valuable service to your customers, call Arcan Enterprises at **888-35ARCAN (352-7226)**

## Vacuum Pipe



## Vacuum Fittings



## Aluminum Camlocks

## Consolidated Pipe & Tube Co., Inc.

Fittings Flanges Hose Pipe Valves

Custom Fitting Fabrication  
Ph: (806) 763-9591

Kwik~Lokk Coupling Distributor  
[karl@vacpumperparts.com](mailto:karl@vacpumperparts.com)

[www.vacpumperparts.com](http://www.vacpumperparts.com)

# POWERFLO

PRODUCTS INC.

800-758-4788

Shop Online!

www.powerflo.com

**Performer Series PF540**



POWERFLO MODEL:	PF540
Air capacity displacement	330 cfm
Air capacity displacement @ 15" Hg	310 cfm
Maximum vacuum	95%
Maximum pressure	30 psi
RPM	1200
Weight	357 lbs

**Jurop**  
PORDENONE

**R260**

- 304 cfm @ 18"
- Air Cooled



The Original **DC-10**  
Heavy-Duty Washdown Pump

**Nylon Secondary**

- 2" - \$166
- 3" - \$217



**Low Pro Primary**

- 3" - \$273
- 3" NPT - \$308

**Lever Action Gate Valve**

- Brass
- 3" - \$98
- 4" - \$121
- 6" - \$215

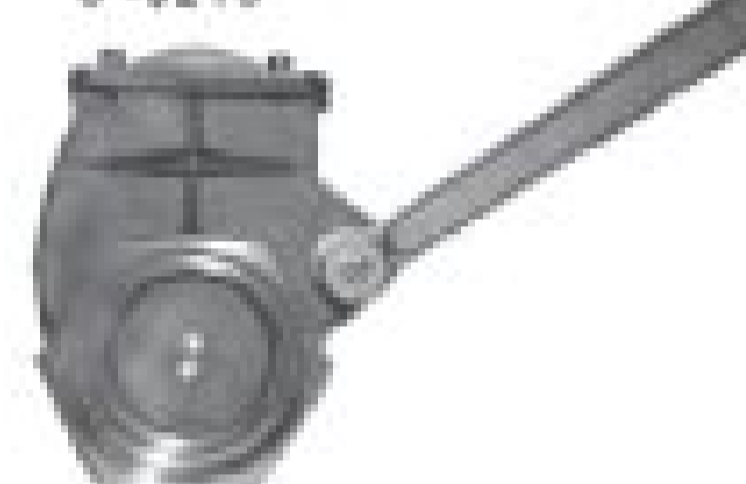

**Piston Action Gate Valve**

- Brass
- 6" - \$183
- 4" - \$110



**Manway Special Gasket in lid**

- 17" - \$172
- 20" - \$254

**RT Angle Gearbox**

- 1" - \$227
- 1 1/4" - \$345



**PUMP VANES**

**BULLET-PROOF**  
your pump with  
**KEVLAR BLADES**

**DURA FLO BLADES**

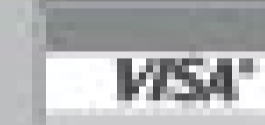

POWERFLO PRODUCTS INC. • 2755 N. Gaviota Ave. • Signal Hill, CA 90755 • Phone: 562-997-0720 • Fax: 562-997-0724

**2200 Gallon Aluminum Restroom Service**

Masport HXL 4 - 160 CFM pump, dual service, stainless washdown and toilet carrier.

2009 Ford 750XLT

Automatic transmission, air brakes.

Located On Our Lot.

**\$87,900** Plus Freight



**GARAFANO**

The

**VERY BEST**  
TRUCK TANKS & SERVICE



**3600 Gallon Aluminum Septic Service**

Masport pumping system, Toolbox

New! International 'Pre-Emission'

310 H.P., 10 speed transmission

Call for complete specifications and price!



Contact: Peter Garafano, Cell: 973-202-2693

Garafano Tank Service

500 Marshall Street, Paterson, NJ 07503

Tel: 973-345-9200 / Fax: (973) 345-7633

Sales, Service & Parts  
Truck Tanks  
Garvac Tanks  
Garfo Leasing  
Frame Straightening

Valve Heaters for your Septic Truck  
**"Arctic Valve Heaters"**

Heat the Valve, Not the Sewage

SIMPLE — EFFECTIVE — SAFE

No piping changes or welding needed on your truck.

For: 3", 4" or 6" Lever Valves

Developed by the inventor of the Arctic Blaster

And **THEY WORK!**

**ORDER NOW!**  
HAVE IT THE DAY YOU NEED IT!



The Amazing **ARCTIC BLASTER**  
Thawing Device

- > THAWS PIPES ABOVE & BELOW GROUND
- > USE ON PLASTIC, COPPER OR ABS
- > EXCELLENT MONEY MAKER

**ARCTIC BLASTERS INC.**

SUNDRE, ALBERTA

403.638.3934

Fax: 403.638.3734

# Mid-Continent Truck Sales, Inc.

891 Adkins Hill Rd. • Norman, OK 73072 • 405-329-5365 • Fax: 405-329-5381 • After Hours: 405-826-4469 • www.vacuumtrucksales.com

*Trucks — Trailers — Vacuum Tanks — Pumps*



1998 IH 4700, DT466E, 6-spd., double frame, MEC8000/PAL vacuum pump, 1600 gallon vacuum tank.



1999 IH 9900, Detroit 60 series (430/500 hp), 10-spd., new Wally 753LN vacuum pump, new 3000 gallon vacuum tank.



1998 Freightliner FL60, Cummins 5.9 (210 hp), 6-spd., Masport H75V vacuum pump, General 47 series triplex, 1100/200 gallon vacuum tank.

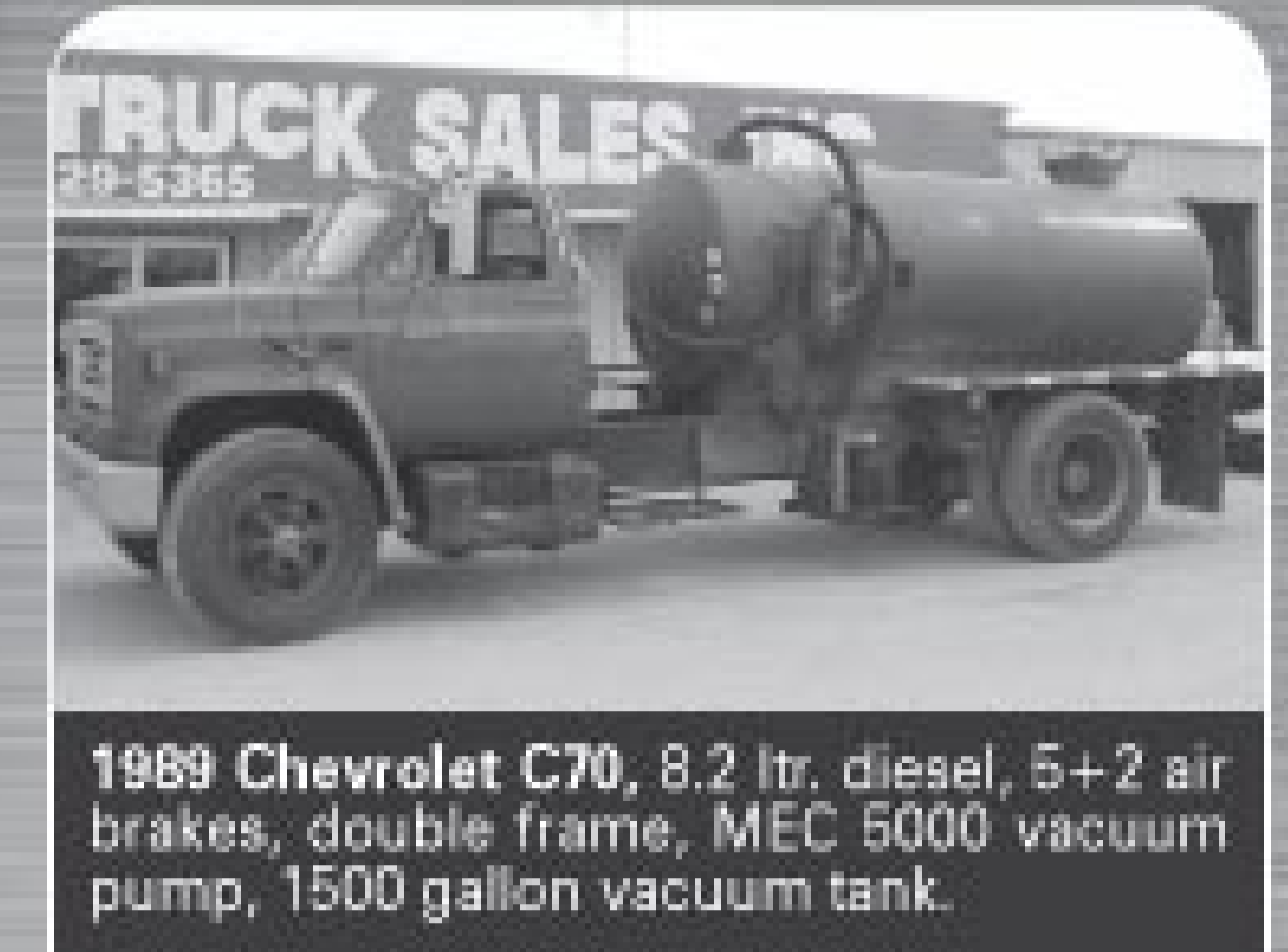

1989 Chevrolet C70, 8.2 ltr. diesel, 5+2 air brakes, double frame, MEC 5000 vacuum pump, 1500 gallon vacuum tank.



**WE WILL BUILD TOILET UNITS TO YOUR SPECS!**



**NVE Masport**

**WE CARRY MOST BRANDS OF VACUUM PUMPS AND PARTS!**



**MID-CONTINENT TRUCK SALES** manufactures and stocks all necessary components to complete your vacuum system. Whether it's pumps, valves, moisture traps, oil catch mufflers, pump frames, etc. **CALL US BEFORE YOU BUY!!**



**NEW 3800, 3400, 3000, 1600 GALLON VACUUM TANKS IN STOCK!**

Call **DAVE PERRY** for TRUCK quotations and **ED PERRY** for TANK quotations.

UNRESERVED PUBLIC AUCTION

**Orlando, Florida**



4- Unused- 2008 Labrie Juggler J10 mtd on 2009/2008 Freightliner M2 Tri/A c/w 4,800 gal 2 comp't tank (3,600 gal solids/1,200 gal liquid), solid-liquid separating unit, NVE 953 (872 CFM) vacuum pump

For complete equipment details and photographs, visit our web site at [rbauction.com](http://rbauction.com)

**OCTOBER 27 & 28**

Auction location:  
700 Ritchie Rd, Davenport, FL  
863.420.9919

**rb RITCHIE BROS.**  
Auctioneers  
**AUCTIONS DONE RIGHT.**

**Agribusiness Supply Company**  
**800-881-6720**

**Call us for a free catalog!**



Metaltecnica Lever Valves  
Metaltecnica Piston Valves  
(Threaded and Flanged)  
Hydraulic and Air Cylinders  
Italian Fittings  
Secondary Shut-Offs  
Camlock Hose Couplings  
Superex Super T-Bolt  
Hose Clamps  
Vacuum Tank Accessories



1212 W. 7th St.  
PO Box 508  
Cedar Falls, IA 50613

# Pumper CLASSIFIEDS

## ADVERTISING

### SANITATION POSTCARDS & BUSINESS CARD MAGNETS:

Remind your customers and prospects with color postcards and magnets. Economical marketing tools. Tradeshow handouts as well. Call 781-844-8600. Visit [www.sanitationpostcards.com](http://www.sanitationpostcards.com).

(PBM)

## AERATORS

PURCHASE AEROBIC TREATMENT PLANT BRAND NAME REPLACEMENT AERATORS ONLINE. <http://www.replacementaerators.com>. Mo-Dad, CajunAire, Jet-air, Econo-HP. <http://www.poundssewersystems.com>. Email: [LbsSewer@aol.com](mailto:LbsSewer@aol.com).

(P10)

## BLOWERS

**VFC200P-5T, FUJI** Pumps, Regenerative Blowers, Ring Compressors. All models, accessories. Authorized distributor. Authorized parts and repair center. Call 888-227-9822. [www.carymfg.com](http://www.carymfg.com).

(PBM)

## BUSINESSES

**Looking to sell your industrial cleaning, hydroexcavation or waterblasting business?** We have buyers. Must have gross revenue in excess of \$1,000,000 annually. Nationwide interest. E-mail [jeffb@colepublishing.com](mailto:jeffb@colepublishing.com) or call 800-257-7222 and ask for Jeff Bruss for more details. **A B2 Business Brokerage Listing.**

(PBM)

**Looking to sell your business?** We can effectively market your business to more than 100,000 potential buyers in the liquid waste, portable sanitation, and sewer & drain industries, as well as your local markets, the Internet and other venues. No upfront fees — you don't pay unless your business sells. To learn more about brokering your business through B2 Business Brokers powered by Pumper, call 800-257-7222. (PBM)

## BUSINESSES

**Florida Plumbing & Sewer Business For Sale.** Established in 1969, owner is moving on. Nearly 8,000 customers in database including some contracted. Business grosses in excess of \$1 million. Extensive equipment including septic, Guzzler and Safe Jet trucks. Equipment has been featured in Cleaner magazine. Asking price is \$649,000. Make an offer. E-mail [jeffb@colepublishing.com](mailto:jeffb@colepublishing.com) or call 800-257-7222 and ask for Jeff Bruss for more details. **A B2 Business Brokerage Listing.**

[www.BTwo.biz](http://www.BTwo.biz). (PBM)

Family owned portable toilet business. Owner with health issues forces sale. 500+ units, 4 service trucks, located in beautiful Sacramento, Calif. area. 16 years established business, loyal customers. Serious inquiries only. Leave message; will return calls. 916-343-3326. (PBM)

**Turn-Key Business:** 25 years, great customer base for sale in Arizona. We are large in real estate inspections, septic pumping, grease traps, oil inspectors, sewer treatment plants, federal government, state, and local government contracts. \$750,000. Sale due to IT'S TIME TO RETIRE!!!! Interested parties call 928-279-6062. This is my personal cell phone; if no answer leave message and I will return your call ASAP. Ask for John. (P9)

**Well-Established and Profitable Texas Septic, Sewer & Installation Business For Sale. PRICE RECENTLY REDUCED.**

Grossing in excess of \$600,000 annually, customer list of nearly 2,000 accounts and 430 contracted customers. Includes nice late model equipment, most are 2007, 2008 model years. Owner retiring after nearly 40 years in business. Real estate available upon request. Reduced to \$450,000. E-mail [jeffb@colepublishing.com](mailto:jeffb@colepublishing.com) or call 800-257-7222 and ask for Jeff Bruss for more details. **A B2 Business Brokerage Listing - www.BTwo.biz.**

(PBM)

## BUSINESSES

**Successful business with a large amount of equipment and inventory.** Profitable sewer and septic business in central Pennsylvania. Increasing revenue over the past 3 years and a large amount of equipment and inventory. Equipment is a mix of old and new, but all is working and making money. Selling price \$349,000. E-mail [jeffb@colepublishing.com](mailto:jeffb@colepublishing.com) or call 800-257-7222 and ask for Jeff Bruss for more details. **A B2 Business Brokerage Listing - www.BTwo.biz.**

(PBM)

Alabama Portolet Business: 40 units, 2004 F 350 crewcab w/Best 150/400 stainless tank. \$35,000 negotiable. 205-938-5195. (P11)

**Philadelphia/Allentown Pennsylvania Area Sewer Business For Sale.** Specializing in collection systems, video inspection, jetting, municipal work. Includes CUES TV & grout truck, Sewer Equipment Corporation jetter truck, Vactor 2100, RIDGID camera, confined space equipment and more! Good revenue history. Great opportunity to expand or start your own business. Current owner wants to retire. **Offered at \$330,000.** E-mail [jeffb@colepublishing.com](mailto:jeffb@colepublishing.com), visit [www.BTwo.biz](http://www.BTwo.biz), or call 800-257-7222 and ask for Jeff Bruss for more details. **A B2 Business Brokerage Listing.**

(PBM)

MOVING TO FLORIDA? Would you like to start a septic and sewer cleaning business? I have license - will sponsor. For more information call Larry at 931-277-5541 or 931-248-1284. (CP10)

BACKHOE, SEPTIC PUMPING, INSTALLATION BUSINESS: Central Illinois. Established 15 years. Most work is in a 40-mile radius. Very nice town; 25 miles from University of IL. Will train and get you licensed. \$90,000. 217-417-0374. (P10)

PORTABLE TOILET/SEPTIC PUMPING BUSINESS FOR SALE IN FRESNO, CA: 60 double trailers, 10 single trailers, 5 triple trailers, 60 skid units, 55 skids w/sink, 4 handicap units, 2 holding tanks, 7 free standing sinks. All blue/white PolyPortables. 2003 International 1500 gallons, 2004 Chevy 3500 450 gallons, 1991 Chevy delivery truck, and 3 delivery trailers. Also willing to sell equipment individually. For more information please call Leo at 559-269-3270. (PBM)

## BUSINESSES

**Dallas/Fort Worth Texas Area Sewer/Rehab Business For Sale.** Drain Cleaning, TV inspection, Pipeline & Manhole Rehab/Relining, Municipal Cleaning and Maintenance business for sale. Excellent opportunity to expand or start your own business. Good revenue history and priced to sell. Includes all equipment to get started. **Offered at \$150,000.** E-mail [jeffb@colepublishing.com](mailto:jeffb@colepublishing.com), visit [www.Btwo.biz](http://www.Btwo.biz) or call 800-257-7222 and ask for Jeff Bruss for more details. **A B2 Business Brokerage Listing.**

(PBM)

4-year-old business in North Idaho/Eastern Washington. Locally owned/operated. 162 units, sinks, trailer, 2001 3/4 Dodge Cummins with Erickson tank 270/100. Extra Best tank 300/100 1600 gal. septic/transfer truck, chemicals. Everything goes. Asking \$180,000. 208-818-9805. (P10)

**Established portable restroom and septic service business located in central Virginia.**

Excellent gross each of the past 3 years with no decline in revenue makes this business recession-proof. Steady work including many contracts and repeat customers. Extensive equipment inventory, good revenue, and owner willing to train. Great opportunity for expansion or a new career. Asking price \$775,000. E-mail [jeffb@colepublishing.com](mailto:jeffb@colepublishing.com) or call 800-257-7222 and ask for Jeff Bruss for more details. **A B2 Business Brokerage Listing. www.BTwo.biz.**

(PBM)

1992 established Port-A-John business in South Texas for sale, \$175K; Last year's rental \$120K; annual & seasonal contracts included. Also included are 2006 F-450 diesel, 500/300 self-contained unit, 80 porta potties, 5 holding tanks, and 18' trailer. 830-334-4388. (P10)

**Northern Minnesota Septic & Drain Cleaning Business For Sale.**

Established in 1965, owner is retiring. 3,500 customers including some contracted. Well-established name for 45+ years. Real estate available for additional fee that adjoins municipal dump site. Hunt, fish, snowmobile right out your back door. **Affordably priced at \$50,000.** E-mail [jeffb@colepublishing.com](mailto:jeffb@colepublishing.com) or call 800-257-7222 and ask for Jeff Bruss for more details. **A B2 Business Brokerage Listing - www.Btwo.biz.**

(PBM)

## BUSINESSES

**North Carolina Septic and Installation Business for Sale.** Showing good growth over the past 3 years. Includes all equipment to operate, extensive customer list, and owner is willing to train if necessary. Asking \$110,000. E-mail [jeffb@colepublishing.com](mailto:jeffb@colepublishing.com) or call 800-257-7222 and ask for Jeff Bruss for more details. **A B2 Business Brokerage Listing; www.BTwo.biz.**

(PBM)

**South Florida Commercial Real Estate, Plumbing, Septic & Sewer Business For Sale.**

Established in 1969, owner is moving on. Nearly 8,000 customers in database including some contracted. Established name with real estate appraised in excess of \$2 million, business grosses in excess of \$1 million, close to \$1 million in equipment including Vactor, Guzzler and Safe Jet trucks. Equipment has been featured in Cleaner magazine. Assumable SBA loan for bulk of selling price. \$2,799,000 for the entire package. E-mail [jeffb@colepublishing.com](mailto:jeffb@colepublishing.com), visit [www.Btwo.biz](http://www.Btwo.biz) or call 800-257-7222 and ask for Jeff Bruss for more details. **A B2 Business Brokerage Listing.**

(PBM)

Portable Toilet Company for sale in Suffolk County, NY. 2 porta-pottie trucks (service & delivery), 2 trailers (10 units & 12 units), 75 portable toilets, 5 handicap units, 2- 4 person handwash stations, 300 gallon holding tank. Asking \$95K - serious inquires only. Call 631-472-1487.

(PBM)

**Green Bay, Wisconsin Area Septic & Drain Business For Sale.**

Solid and steady revenue history and nearly 20 years established. Excellent opportunity to expand or start your own business. Includes very well-maintained 3,800 gallon septic service truck, fully outfitted 2002 Chevy drain service van, drain & sewer equipment, all office equipment and computers, 2,700+ customer list, and more; a true turn-key or easy expansion opportunity. Very meticulously maintained equipment all kept inside a heated shop. Current owner is retiring. Large shop and real estate is also available if desired at additional cost. **Offered at \$249,000.** E-mail [jeffb@colepublishing.com](mailto:jeffb@colepublishing.com), visit [www.Btwo.biz](http://www.Btwo.biz) or call 800-257-7222 and ask for Jeff Bruss for more details. **A B2 Business Brokerage Listing.**

(PBM)

## BUSINESSES

**WANTED:** Looking to acquire septic businesses in Massachusetts. All inquiries will be confidential. 508-868-7627. (PBM)

Bud's Septic Tank Service: Septic Cleaning Business For Sale: 25 years established. 1989 GMC truck, 1200 gallon tank. Payette, Idaho. Phone 208-642-4160 or 208-739-0235. (P11)

**New Jersey VIP Restroom/Portable Toilet Business For Sale.** Servicing Metro Philadelphia and Southwest New Jersey with VIP restroom trailers and portables. Many late model assets including 2 nice service trucks, 1 back-up service truck, pick-up truck, 4 VIP restroom trailers, nearly 300 restrooms, sinks, holding tanks, slide-in unit, 2 forklifts, and more. Assets worth over \$300,000 - priced to sell at \$399,000. E-mail jeffb@colepublishing.com or call 800-257-7222 and ask for Jeff Bruss for more details. A B2 Business Brokerage Listing - www.BTwo.biz. (PBM)

**Looking to sell your portable restroom business?** We have buyers looking in the following areas: Florida, California, Virginia, Iowa, Kentucky, New York, Pennsylvania and more! Must have gross revenue in excess of \$250,000 in most cases. E-mail jeffb@colepublishing.com or call 800-257-7222 and ask for Jeff Bruss for more details. A B2 Business Brokerage Listing. (PBM)

**Chicago-Area Biosolids, Land Application, Dredging and Industrial Services Business.** Established in 1985, owner is retiring. Reputable business includes real estate servicing the entire Chicagoland area with sludge and biosolids disposal and treatment services. Real estate and shop included with sale valued at \$750,000, business grosses in excess of \$3 million annually, \$6.3 million in equipment and assets including several TerraGators, Vac Trailers, dump trailers, loaders and much more. Offered at \$4,900,000 - huge potential, good profit and priced right. Non-Disclosure Agreement required, all P&L statements, list of assets, and financials available to qualified buyers. E-mail jeffb@colepublishing.com or call 800-257-7222 and ask for Jeff Bruss for more details. A B2 Business Brokerage Listing - www.BTwo.biz. (PBM)

## BUSINESSES

**Looking to buy a business** in the liquid waste, portable sanitation, or sewer & drain industries? Call B2 Business Brokers powered by Pumper at 800-257-7222 and we can add you to our VIP buyer list. No obligation, no fees, no pressure. (PBM)

## BUSINESS OPPORTUNITIES

**National Grease Recycling Inc.** Let us teach you how to recycle restaurant's waste fryer grease and oil (yellow grease) only. **No trap grease.** Big \$. Over 30 yrs. experience. Will guide you through complete process from collection to processing to marketing to end users. Don't lose your trap business to competitors that offer both services. We also buy cooking oil, unprocessed, anywhere in the country. Call for information. Dewey Walker. 813-752-9535 or 813-758-2552. (PBM)

**Looking to sell your business?** We can effectively market your business to more than 100,000 potential buyers in the liquid waste, portable sanitation, and sewer & drain industries, as well as your local markets, the Internet and other venues. No upfront fees — you don't pay unless your business sells. To learn more about brokering your business through B2 Business Brokers powered by Pumper, call 800-257-7222. (PBM)

**WWW.ROOTERMAN.COM.** Franchises available with low flat fee. New concept. Visit web site or call 1-800-700-8062 x26. (CPBM)

**Attention PolyJohn Owners:** Receive a **free CD-Rom** of our products to use in your company marketing efforts. Ask your PolyJohn business coach in your area to send you this material today. 1-800-292-1305 Kell. (PBM)

## COMPUTER SOFTWARE

**Money tree!** Critical business tools: Reminder cards, job tracking & more. 30-Day Money-Back Guarantee! Special \$139.59 expires soon. **Summit Reminders Plus™** software. Ritam Technologies - www.ritam.com - 800-662-8471 - 208-629-4462. (P10)

## COMPUTER SOFTWARE

Pumper Plus Billing Software: Regularly \$795. Mention this ad in Pumper.com and purchase for only \$595. Pumper Plus is a billing software package from Galaxy Systems. www.galsys.com/pumperdemo.asp, that handles billing for septic pumping and portable toilet service-type companies. Inquire at solutions@galsys.com or call 800-985-3029. (PBM)

## DEWATERING

22-yard dewatering box w/steel rolling tops. Does not include filter media or polymer injection system. Asking \$23,000. 770-917-0377 GA. (P10)

Stainless Steel BELT PRESS For Sale: Made by Nijhuis, 1.6 meter (63" belt size) in perfect running condition. \$39,000. Call Sergio at 951-545-0649 or email at Sergio@co-west.com. (P10)

ALAR 660 AUTOVAC DEWATERING PLANT. HUGE SAVINGS ON DISPOSAL COSTS!!! MUST SELL. Price reduced to \$40,000. Complete plant, like new. Vac skid with electrical control panel, fully automated system. Grease interceptor and septic separation primary use. All electric, location plans, manuals. Too much to list! CALL TODAY. 808-848-1569. (P10)

Septage dewatering equipment. Includes 1 meter belt press, rotary sludge thickener, polymer unit, storage tanks, etc. Equipment is in operation. To view a video or for more information call 541-269-9020. (P10)

Buy - sell - trade - lease: Filter presses, belt presses, vacuum filters, filter cloth, dewatering bags, tanks, mixers and more! Call Waste Treatment Equipment Specialties at 440-808-8844. **www.wescoequip.com.** (PBM)

## DRAINFIELD RESTORATION

**Soil Shaker 2000.** Universal skid steer attachment for drainfield restoration. Buy factory direct \$5,950. www.soilshaker.com or call 320-293-6644. (PBM)

Model 2000 Terralift, extremely low hours, 3 probes, beads, excellent condition. \$15,000. 970-209-1895. (PBM)

## GREASE SEPARATOR

**BROWN GREASE SEPARATOR: A Solution For Grease Trap Waste.** Downey Ridge Environmental Company offers a patent-pending system consisting of a 10,000 gal. tank with boiler burning 100% brown grease as fuel resulting in brown grease recovered and sold as a commodity. Ph 304-658-4778 or Jim at 304-222-9248. (P10)

## HAZARDOUS WASTE UNITS

2011 Freightliner with new Presvac 3200 gallon, carbon steel, DOT 412 certified, full open rear door, dump style units, PVB750 vacuum pumps. *In production.* (Stock #13444 B, C & D) **www.VacuumSalesInc.com, (888) VAC-UNIT (822-8648).** (PBM)

1997 Freightliner with Presvac 2300 gallon DOT certified vacuum tank, Presvac PV750 vacuum pump with new paint and tank inspections. KLM Companies, 617-909-9044. (P10)

2011 International 7500 with a Presvac 3,200 gallon carbon steel vacuum tanker. DOT certified 407/412, with a PVB-750 pump package. (Stock #13437A) **www.VacuumSalesInc.com, (888) VAC-UNIT (822-8648).** (PBM)

1987 Pete 379 with Presvac 3000 gal. stainless steel dump/door, DOT certified vacuum tank, Presvac PV750 pump, Cummins big cam with alum. budds. KLM Companies. 617-909-9044. (P10)

NEW Presvac 5500 gallon c/s DOT certified vacuum tank trailer unit, with a PV750 pump, Deutz diesel. (Stock #13373) **www.VacuumSalesInc.com, (888) VAC-UNIT (822-8648).** (PBM)

2011 Freightliner M2 with new Presvac 3,200 gallon stainless steel DOT certified dump and door vacuum tank. 900 CFM blower, 330 HP. KLM Companies, 617-909-9044. (P10)

## HYDROEXCAVATION

E. H. Wachs Trav-L-Vac vacuum trailer model TL8700, 400 gallon dump tank, blower type pump, Duetz 40 hp engine, tandem trailer. \$5,500. Michigan. 616-218-3155. (P10)

## JETTERS-TRAILERS

2 SECA trailer jets. Both have Myers 35 gpm, 2000 psi pumps. New paint on both. Located in Dallas. 972-938-1905. **www.empireequip.com.** (CPBM)

2005 Harben/Stormco enclosed trailer, auto reel, 250 gal. tank, Harben motor. Need to rebuild pump. Trailer is brand new. Must sell. \$9,500. 484-225-1442. (P11) **Xtreme Flow Cold Jetter - New!** Model # CJ85-3600TU, tandem axle trailer, 35 HP Vanguard, 8.5 gpm @ 3,600 psi, 325 gal. water tank, 300' hose, General pump. List \$19,995. **Sale only \$14,995. Fully loaded!** 800-624-8186; **www.hotjetusa.com.** (CPBM)

2003 O'Brien Custom Hydro, Model 10580-SC, Cummins 6BT 6 cylinder 5.9 turbo, Myers FE high pressure pump, 80 gpm, 2000 psi, 600' hose, tandem axle trailer, pintle hitch. \$25,000. Call JD 775-825-1595 or, jd@watersvacuum.com. (P10)

## JETTERS-TRUCKS

2000 Chevrolet C8500 jetter truck, Myers DP80 jetting pump, 1" jetting hose, rear engine Cat Diesel, 3435 hrs. Please call 972-938-1905 or 972-679-5124. (P10)

**WHY BUY NEW?!** Standard Equipment Company sells and rents used and reconditioned combination sewer cleaners, jetter trucks and trailers, catch basin cleaners and hydroexcavators. **www.standardequipment.com** or call Joe, 312-706-9678. (P10)

2006 GMC TC6500 cab & chassis truck mounted jetting unit with JET EYE camera system, 3,000 psi @ 50 gpm, 1,000 gallons water, 600' hose, 500 cfm blower, 1/2-yd. debris tank and attachments. **\$149,000 purchase price!** (Stock #13234) **www.VacuumSalesInc.com, (888) VAC-UNIT (822-8648).** (PBM)

**WE BUY USED!** Combination sewer cleaners, jetter trucks and trailers, catch basin cleaners and hydroexcavators. All makes and models; old or late model. Call Tom at 312-706-9636. (P10)

## JET VACS

Jack Doherty Supplies Inc. offers a full range of late model combo units and DOT industrial vacuum loaders. Call us @ 1-800-3DOHENY. (CPBM)

1998 Vactor 2110 on a Freightliner FL80, 28,213 miles, 2-stage fan, 80 gpm, 2,000 psi pump off system accumulator. Was a city owned unit. Located in Dallas. 972-938-1905. www.empireequip.com. (CPBM)

1996 Vac-Con on Ford chassis, newer 3-stage fan, reasonable hours and mileage for age. Good second or entry to business. \$38,900. Call NJ 732-887-2988. (P10)

**WE BUY USED!** Combination sewer cleaners, jetter trucks and trailers, catch basin cleaners and hydroexcavators. All makes and models; old or late model. Call Tom at 312-706-9636. (P10)

2005 Vac-Con on 2005 International, ext. boom, articulating reel, 39,000 miles, 3,950 hours. Call Ken for more info. 904-993-5211 or 904-744-9138. (CP10)

**WHY BUY NEW?!** Standard Equipment Company sells and rents used and reconditioned combination sewer cleaners, jetter trucks and trailers, catch basin cleaners and hydroexcavators. www.standardequipment.com or call Joe, 312-706-9678. (P10)

## LEASE/FINANCING

**North Star Commercial Credit:** Commercial Loans for Trucks or Equipment. Flexible purchase programs to fit your budget. 21 yrs. in the industry. Contact **Tom Myers - 877-804-2274.** (CPBM)

## MARINA/OIL PUMPOUT

Marina pumpout shallow water barge, 1000 gallon tank, Hibon blower vacuum/pressure, Honda engine, water pump/tank, skimmers/hoses, many extras. Call Pat's Pump & Blower. 800-359-7867. (P10)

IF YOU ARE USING AN  
**800 NUMBER**

IN YOUR AD, BE SURE IT CAN BE  
USED IN ALL AREAS NATIONWIDE.

## MISCELLANEOUS

FINALLY! One-man septic lid lifter. Lifts lids with incredible ease. Free shipping, lifetime warranty. Send check or money order for \$230.00 to Brindlee Mtn. Rooter, 130 Co. Rd. 1829, Arab, AL 35016. 256-586-5948. (P03)

New custom built rotary screen for processing/screening septic or grease trap waste, also other liquid material. Originally constructed to screen waste prior to land application, 7'X16' containment box, 12'X3" rotary screen. Works extremely well based on 7 years operating experience. \$30,000. Call JD 775-825-1595 or email jd@watersvacuum.com for pictures. (P10)

## PARTS & COMPONENTS

PARTS & SERVICE for vacuum pumps and vacuum tanks. Vacuum pumps also in stock. Chambersburg, PA. 717-709-0000. Ask for Ken or Randy. (PBM)

## PORTABLE RESTROOMS

25 PJ3 POLYJOHN Express Units For Sale: Good condition, grey, used only for parties, \$300 each OBO and 7 sink stations. Also, 2009 Century II mobile restroom trailer, \$14,000 OBO. Visit www.poopypotties.com or call 810-714-0935 Gretchen. MI. (P10)

35 2-yr.-old Five Peaks units, excellent condition. \$350 each. Shipping available. 402-217-1118. (P10)

PolyJohn PJ3s, blue with white tops, plastic skids, 5-8 years old, construction grade, 120 available, \$175 each. Located in NY. 800-275-3616. (P10)

Over 600 PolyJohn units 1-2 years old. Starting at \$300 each. Minimum purchase of 26 units. 772-562-4604. kim@reliablepolyjohn.com. (PBM)

New, used for only one event. FIVE PEAKS, green, purple, yellow, rwb, teal. Also 80 SENERGYS. \$350.00 pr; 10-4 station sinks \$75.00 pr. 608-835-3459. (P11)

120 PolyJohn PJ3 units, dark green, \$150 each. Good condition. 865-740-1654 or pattbro@tds.net. East TN area. (PT10)

## PORTABLE RESTROOMS

16 Armal Starlight Units. Beige with gray front. NEVER USED! \$250 each or \$3,600 for the lot. SE South Carolina. 843-338-1826. (P12)

Used PolyJohn, PolyPortable tan units, plastic skids, average to excellent condition. \$200-\$300 each. Can arrange shipping. Call Bob at 1-352-796-4540. (PBM)

**GOING OUT OF BUSINESS!** Good condition \$75-\$150 ea; special event units \$150-\$225 ea; half units \$175-\$250 ea; handicaps \$600 ea. All PolyPortables, PolyJohns, Five Peaks, Satellites MUST GO! Contact Manuel @ 305-970-9837 or email malonso@port-o-tech.com. (P10)

Used Satellite, PolyPortables and Taurus for sale, \$175 ea. Located in West Tennessee. 1-901-452-7040. Ask for Josh. (P10)

## PORTABLE RESTROOM TANKS

300 gallon, 225 waste/75 water, brand new, Battioni pump. \$5,500. 315-375-7867. (PBM)

Single or multiple compartment tanks. Choose mild, stainless, or galvanized steel. Capacities from 100 to 6000 gallons, any diameter. Parts and accessories to build your own and save money. 800-545-0174. www.tanksandpumps.com. (PBM)

## PORTABLE RESTROOM TRAILERS

3 Decons. McKee portable toilet transport trailers, 3-12 pack; 2-6 pack. American Engineering 828 Tonto and 814 Royale. 315-437-1291. (P10)

32 foot Portable Trailer with mens & womens restrooms. Used only once. Call/email for more details. Asking \$7,000 OBO. 218-348-2898; tanskisridgeview@hotmail.com. (P10)

1995 14' Oasis Unisex, 7 private entrance stalls w/hand sanitizers, one 6' urinal trough, \$6,000. 1995 28' Olympic, 5 womens stalls, 1 mens stall w/4 urinals, 2 sinks on each side, AC & heat. \$11,000. Call John 610-705-5555 or les@pottyqueen.com. (P10)

## PORTABLE RESTROOM TRAILERS

2007 JAG Portalisa. 1 womens and 1 mens stall. Perfect size for weddings and smaller events. Seldom used. \$10,000. Chris 218-343-0108. (P10)

2008 24' Olympian Executive, (3) ladies stalls, (1) sink, (1) mens stall, (3) urinals, (1) sink, heat, hot water, A/C. Never used - paid \$28,500 will take \$25,000. Call 866-883-9538. (P10)

New and used **RESTROOM TRAILERS** available immediately. 8 to 34 foot luxury trailers. Comforts of Home Services Inc. 877-382-2935. (PBM)

## PORTABLE RESTROOM TRUCKS

2008 Dodge 5500, Cummins, automatic, 50,000 miles, 1000 waste, 300 fresh, under warranty, \$52,000. 2008 Ford 550, diesel, automatic, 64,000 miles, 950 waste, 300 fresh, still has warranty, \$47,000. Rodney Lane cell 270-832-3793. (PBM)

1999 Chevy 3500HD, 454 gas engine. 300 gal. waste, 200 gal. fresh water, Richmac tank. 130,000 miles on truck. Everything works on this animal. We purchased a new truck this year and don't use this one any more. \$6,500. Call Wade 920-573-3646 WI. (P11)

2006 F-550 Pumper Truck, 6 liter diesel, A/T, 950 gallons waste, 330 gallons freshwater, Masport pump, great condition, 112,200 miles. \$30,000. For more details call 1-866-686-3603. (P10)

2000 F450 Satellite toilet truck, auto, diesel, 600 waste/250 water, 2-toilet carrier. \$6,500. Will separate. 845-863-6080 NY. (P10)

1999 International 4700, 6-speed transmission, 268,000 miles, 1200 gallon waste/350 gallon fresh. Non-CDL. \$15,000. Call John 610-705-5555 or e-mail les@pottyqueen.com. (P10)

1996 Isuzu pump truck. Truck used daily. New tires and brakes. 197K miles. 200/600 tank. In good condition. \$4,500. Call Brett @ 352-446-0475. (P10)

2003 F550, diesel, auto, AC, Satellite 2-toilet carrier, 650 waste/300 water. \$7,500. Will separate. 845-863-6080 NY. (P10)

## PORTABLE RESTROOM TRUCKS

2003 Ford F-350, 4x4, auto, flatbed w/liftgate. Carries 5 units. New alum. tank, 300 waste/135 fresh, Conde Super 6 pressure vac pump w/5.5 hp Honda electric start. Real nice condition. \$25,500. www.pumpertrucksales.com. Call Mike @ 303-478-4796 or JR. @ 720-253-8014. (PBM)

2004 4300 International, 25,500 GVW, DT466, Allison, A/C, air-brakes, 3-compartment aluminum tank (450/1400/250), M-10 water-cooled pump, spot lights, 2 Burk water pumps for fill and spray down, restroom carrier. Pictures www.aacoinc.com/classified. Location Phoenix, AZ and Las Vegas, NV. \$30,000. 208-362-3193. (P10)

1997 GMC 6500, motor and trans. rebuilt. The tank is 600 gal. waste and 225 gal. fresh water. \$8,500. 901-452-7040. Ask for Josh. (P10)

Pre-owned 325 US gallon vacuum tank with two (2) 75 gallon poly water tanks mounted on a 2007 FML Fabform Trailer model FMI12-10K Workmate. (Stock #0477) **www.VacuumSalesInc.com, (888) VAC-UNIT (822-8648).** (PBM)

2004 Chevrolet 4x4 2500, 300 gal. waste and 175 gal. fresh water. \$8,500. 901-452-7040. Ask for Josh. (P10)

1998 Ford F-Series, 26,000 GVW, 116,000 miles, 6-speed, 6-cylinder Cummins diesel, Battioni vac, 3-compartment tank, 750 waste, 200/100 freshwater. \$13,000 OBO. 262-675-2497. (P10)

2000 International 4700, 7-speed transmission, 278,800 miles, 1000 gallon waste/400 gallon fresh, Non-CDL. \$16,000. Call John 610-587-8879 or e-mail les@pottyqueen.com. (P10)

1994 International 4700 with 2003 Keith Huber 1100 US gallon waste, 400 US gallon water, 2-compartment, carbon steel vacuum tank, with Masport H7.5V vacuum pump. (Stock #6499C) **www.VacuumSalesInc.com, (888) VAC-UNIT (822-8648).** (PBM)

1996 Chevrolet pump truck. Great starter truck. 257K miles. New engine @225K miles. Sale price \$3,500. Call Brett @ 352-446-0475. (P10)

PLACE YOUR AD ONLINE AT [www.pumper.com](http://www.pumper.com) - IT'S ALWAYS THERE TO MEET YOUR BUSY SCHEDULE

## PORTABLE RESTROOM TRUCKS

2005 Ford F550, diesel, auto, Satellite 650 waste, 300 fresh, unit carrier, 146,000 miles, \$23,000 OBO. Call 845-883-7880, 8-4:30 EST. (P10)

Prime 1,500 US gallon, 2-compartment (1000/500 split) carbon steel; portable toilet service unit. (Stock #3469C) **www.VacuumSalesInc.com, (888) VAC-UNIT (822-8648).** (PBM)

### GOING OUT OF BUSINESS!

Aluminum portable toilet tankers: '02 F-650, \$16K; '02 Inter., \$18K; '03 Inter., \$32K; '04 Inter., \$34K; '05 Inter., \$39K; '06 Inter., \$45K. Contact Manuel @ 305-970-9837, or email malonso@port-o-tech.com. (P10)

2006 Ford F550 XL 2WD Diesel, 139,000 miles Runs and works daily. 1250 gallon Progress aluminum tank. Dual service sides. All hoses and washdown. Burks D/C 10 1000 PSI pressure washer with metal hose reel. Masport HXL4 pump with diesel pump wash system. 400 gal fresh. 4" dump w/2 unit toilet rack. \$35,000. 864-554-1519 or boggero@greenwood.net. (P10)

2004 Int. 4300, stainless, \$42,500; 2002 Int. 4300, \$32,500; 2001 Int. 4700, \$32,500; 2000 Int. 4700, \$25,000; 1998 Int. 4700, \$22,500. 200 restrooms, \$125 - \$300 each. Call 256-757-9900 or visit [www.pbsos.com](http://www.pbsos.com) for more info and pictures. (PBM)

Call A Head Corp. is now taking delivery of 4 new Best Enterprises built pump trucks enabling us to sell 3 2005 and 1 2006 F550 Super Duty pump trucks at wholesale prices. Low, low mileage, these trucks are in showroom condition built with all stainless steel, 1050 gallon tanks (750 water/300 waste), PTO driven Masport pumps, automatics, AC, tool boxes, etc. Starting at \$29,999. Contact Kenny @ 1-800-634-2085. (PTBM)

## POSITIONS AVAILABLE

**Sales Position:** Well established vacuum truck company looking for experienced industrial sales person with vac truck experience for Pittsburg and North Carolina area. Please call Howard 866-766-3822 or email resume to [howard@adlernj.com](mailto:howard@adlernj.com). (P10)

## POSITIONS AVAILABLE

The company is the sales arm of a European manufacturer of sewer cleaning tools in the heavy duty range with very special application know-how. To grow our US sales team we look for: Manager/Salesmanager SME Environmental Products for Contractors/Public Works. The task: • selling heavy duty equipment to distributors and municipalities/public works; • active SME management role (working manager); • pushing sales, overlooking/coordinating our small team; • deployed mainly in the field; • office in North Eastern Georgia. The requirements: • knowledge in water/sewer technologies; • familiar with the world of public works and service contractors; • sales experience, small business management experience. Please send your CV to: [cleanline2010@yahoo.com](mailto:cleanline2010@yahoo.com). (P10)

**SALES POSITION: United Liquid Waste Recycling Inc.,** located in Southeastern Wisconsin, is looking for a salesperson with a direct knowledge of the solid and liquid waste industry. Contact us at 888-558-9611 ext. 119. [united\\_hr@yahoo.com](mailto:united_hr@yahoo.com). (PBM)

## PRESSURE WASHERS

Hot water, mobile wash skids with serious cleaning power. Sold and supported through local distributors. Call 800-274-9376 or visit [www.hydrotek.us](http://www.hydrotek.us). (CMP10)

New Commercial Grade Trailer Special - Single axle, hot water trailer unit, 18 HP Vanguard, 5.0 gpm @ 3,000 psi, with 200 gal. water tank, General pump. List \$11,995. **Sale only \$8,995. Fully loaded! Ready to clean!** 800-624-8186; [www.powerlineindustries.com](http://www.powerlineindustries.com). (CPBM)

## PUMPS-VACUUM

Need a vacuum pump for your portable pumper? Try our new 30 cfm, 12 volt system. Less noise, no fuel. Automatic oiling, cheaper than a gas engine. 800-545-0174. [www.tanksandpumps.com](http://www.tanksandpumps.com). (PBM)

New **Masport** and **Jurop** vacuum pumps. Compare our price before you buy. W-K Machine & Supply Co. Call 1-800-633-8947. Distributor. (PBM)

## PUMPS-VACUUM

**Buy & Sell** all makes and models, **new & used** vacuum pumps & high pressure water pumps, and good used replacement parts. Call for an inventory sheet and save. **www.VacuumSalesInc.com, (888) VAC-UNIT (822-8648).** (PBM)

Vacuum Pumps - New, used, or rebuilt. 30 to 900 cfm. All major brands; air, water, or fan cooled. Rebuild specialists - rebuilt PB, M3, M10, and others available. 800-545-0174. [www.tanksandpumps.com](http://www.tanksandpumps.com). (PBM)

## RENTAL EQUIPMENT

**KMH Equipment Company** has a full range of late model combo units and industrial vacuum loaders for sale, rent or lease. Visit us at our website [www.kmhequip.com](http://www.kmhequip.com) for a complete listing of our equipment, or call us at **888-408-6716.** (P10)

Liquid vacs, wet/dry industrial vacs, combination jetter/vacs, vacuum street sweeper & catch basin cleaner, truck & trailer mounted jettors. All available for daily, weekly, monthly, and yearly rentals. **VSI Rentals, LLC, (888)VAC-UNIT (822-8648) www.vsirentalsllc.com.** (PBM)

## SEPTIC TRUCKS

1988 Mack MR, 5-spd., 4500 gal. Transway tank and pump, tag axle, Hendrickson. \$18,000. 508-548-3412. (P10)

1991 Chev Kodiak, 366 engine, 10000 mi. on OH Masport pump, 2500 gal. tank, recent paint. Ready to work. \$21,000. 928-486-9984. AZ (P11)

1991 International 4900 diesel, 466 engine, 5-spd. trans., 2-spd. axle, 2200 gal. tank, 260 Jurop pump. Runs good; pumps good. \$20,500. Phone 502-352-9613 KY. (T9P10)

2000 Mack CH613 vacuum pumper truck, 3,300 gallon tank w/hydro-jetter, 350 HP, 9-speed trans, 630,000 miles. Hydro-jetter, tank & hoist bed new in '05. 3,300 gallon carbon steel tank w/top manway, 36" rear manway, 3" inlet, 4" outlet, 342 CFM fan cooled Mal vac pump w/12 gallon trap, air operated PTO, hydraulic hoist bed. \$32,000. (Drive axle needs new tires, does not include hoses.) Call 219-819-9010 IN. (P10)

## SEPTIC TRUCKS

1989 Ford Louisville L8000, 4300 gal. tank, wpt 720 Battioni, 7.8 Brazilian motor, good rubber, strong runner. Ready to go to work. \$14,000. Call 616-897-3050 MI. (P10)

1998 Mack RD6885 with a 3,200 US gallon stainless steel vacuum tank unit. (Stock #6653V) **www.VacuumSalesInc.com, (888) VAC-UNIT (822-8648).** (PBM)

2003 Sterling Acterra pump truck, 69,365 miles, 58,000 lbs., 9-speed Fuller Eaton transmission, Cat 3126 300 hp, AM/FM, AC, PS, cruise, Progress 3600 gallon tank all alum., 125 gallon fresh, pressure washer, Wittig pump liquid cooled. \$60,000. 770-317-7089 GA. (P10)

2006 Peterbilt 335, full open rear door. Hoisted tank with all LED lights, new tires. All aluminum wheels. All heated valves. Extremely nice, owners personal truck. Garage kept. All service records available. New truck on the way. \$108,000. 706-234-7252. (P10)

2010 Peterbilt 348s with new Presvac 3,600 US gallon aluminum vacuum pressure tanks with Masport HXL400WV vacuum pressure pumps. (Stock #8807 & 8808) **www.VacuumSalesInc.com, (888) VAC-UNIT (822-8648).** (PBM)

1992 F800 with 2100 gal. tank, 197K, LP gas, Battioni pump, new brakes and paint. Great starter truck. \$9,800. Indiana. 765-914-7583. (P10)

2001 Freightliner FL70, 3050 gal. pumper, 2-tank set-up, w/R260 Jurop pump, ISC 240 hp Cummins, 6-spd., single axle w/lift axle, AC, cruise. Tanks & pump 2 yrs. old. 209,000 miles. Asking \$42,000. 864-592-1234. (PBM)

1981 F-600, 1,800 gallon tank with Masport pump, good tires, great starter truck, \$12,000 OBO. Call 830-334-4388 or 210-385-1055 for more details. (P10)

1989 Ford L9000. 4500 gal. tank, 400,000 miles, tri-axle, 300 Cummins, newly installed engine, clutch, crank seal, Jake brake, adjusted valves, hood hinges/latches, Moro pump (recently rebuilt), double frame (solid), nearly \$16,000 in parts since use. Asking \$20,000 OBO. Call Jim Holden 814-688-4607. (P10)

## SEPTIC TRUCKS

1993 Ford LNT 8000 with 270K, Fuller 10-speed, 250 hp Cummins eng., 3800 gal. Kary Mor aluminum tank. Solid work truck. All hoses on truck included. \$25,000 OBO. Call 847-343-5068 Jim. (P10)

1995 Freightliner, 350 hp Cat, 8LL trans., newer 3365 gal. vac tank, 400 Masport. \$35,000. [www.pumpertrucksales.com](http://www.pumpertrucksales.com). Call Mike @ 303-478-4796 or JR. @ 720-253-8014. (PBM)

1988 International, 2500 gallon tank, two Jurop R260s, good running DT466, worked every day until the truck frame cracked. Best offer. 608-751-1668 WI. (P10)

1997 Mack CH613 E7330, 350 hp, Fuller 10-spd., 54,000 GVW, newer vac tank, 3365 gal., 400 Masport pump. \$35,000. [www.pumpertrucksales.com](http://www.pumpertrucksales.com). Call Mike @ 303-478-4796 or JR. @ 720-253-8014. (PBM)

1999 Freightliner FL70, 2000 gal. tank, fully equipped with hoses and all necessary fittings. Strong working truck. \$39,900. Call 615-794-1776 TN. (P10)

2000 Freightliner FL70, Cummins, 6-speed, 2000 gallon vacuum tank, tank never used, Jurop pump, new, 115,000 miles. \$26,500. Michigan. 616-218-3155. (P10)

1994 F-700, 1,800 gallon tank with Jurop pump, good tires, great starter truck. \$15,000 OBO. Call 830-334-4388 or 210-385-1055 for details. (P10)

Pre-owned 2500 US gallon, carbon steel, vacuum tank only. (Stock #0001V) **www.VacuumSalesInc.com, (888) VAC-UNIT (822-8648).** (PBM)

Need a tank and truck, any size, any make truck? Let us help you get the best deal. Custom built to your specs. For information and a price quote call 800-545-0174. [www.tanksandpumps.com](http://www.tanksandpumps.com). (PBM)

1998 Chevrolet C7500. Caterpillar 3116, 3500 gallon with a Masport H400W. Onboard jetter, hoses. Strong truck! 191k miles. \$42,000. 678-520-6161 GA. (P11)

Five (5) 2003 to 2006 3200 US gallon **stainless steel** vacuum tanks. **www.VacuumSalesInc.com, (888) VAC-UNIT (822-8648).** (PBM)

BUY IT - SELL IT - PLACE IT - [www.pumper.com](http://www.pumper.com) - AVAILABLE ANYTIME, ANYWHERE, ANY DAY



## SEPTIC TRUCKS

2001 Freightliner, 3300 gallons, \$44,900. 1999 Sterling, 3300 gallons, \$44,900. Low miles, ready to pump. VERY WELL MAINTAINED. Michigan. 231-228-7499. (P11)

Pre-owned 2300 US gallon, carbon steel, vacuum tank with Masport H75V vacuum-pressure pump installed on a 1987 Ford L8000 cab and chassis. (Stock #4556V) **www.VacuumSalesInc.com, (888) VAC-UNIT (822-8648).** (PBM)

2004 Intl. DT-466, 130,000 miles, new 2300 gal. tank, \$47,000; 2005 Intl. DT-466, 119,000 miles, 1500 waste, 300 fresh, set up to pump septic or toilets, \$47,000; 2001 Intl. DT-466, new 2300 gal. tank, \$37,500. Rodney Lane cell 270-832-3793. (PBM)

2010 Peterbilt 348 with a new Presvac 3,600 US gallon carbon steel vacuum pressure tank with a Masport HXL400WV vacuum pressure pump. (Stock #8806) **www.VacuumSalesInc.com, (888) VAC-UNIT (822-8648).** (PBM)

1995 Ford LTL9000, 5000 gallon custom tank, w/NEW Moro pump, new tires, low mileage. \$18,500. Call 334-693-5718 or 334-790-9005, Alabama. (P10)

## SERVICE/REPAIR

**Sewer Cam Reel, Camera and Locator Repair:** 48-hr. turn-around time. General Wire, Ratch, Ridgid, Pearpoint, Electric Eel, Gator Cams, Insight Vision, Vision Intruders. Quality service on all brands. For more info. give Jack a call. Dynamic Cable Repairs, Lodi, NJ 07644. 973-478-0893. (PBM)

## SLIDE-IN UNITS

2-yr.-old Imperial Industries slide-in unit, 450 gal. (300 waste/150 fresh), 8.0 Honda engine, electric start, Jurop pump, washdown. \$7,500. 402-217-1118. (P10)

2007 stainless steel 400/200 unit built by Best Industries. Asking \$9000. To make an offer call 1-336-657-0966 ask for Jeff. NC. (P11)

## TANKS

1000 gallon stainless steel vacuum tank, baffle inside, primary and secondary shutoff, one 3" valve. \$3,500. 864-592-1234. (PBM)

## TANKS

Vacuum tanks, 100 to 6000 gallons. All options available; hatches, primary, secondary, valves, catwalks, ladders, etc. Everything needed to build your own septic truck. Choose mild, stainless, or galvanized steel. Ask about full open doors. 800-545-0174. **www.tanksandpumps.com.** (PBM)

**New 3400 gallon tank,** 20' man-way bottom, 3" intake, 4" dump, hose trays, valves, painted. \$12,000. 4000 gallon and many other sizes available. Delivery available. **www.JEagleTanks.com** or **800-721-2774.** (PBM)

Five (5) 2003 to 2006 3200 US gallon **stainless steel** vacuum tanks. **www.VacuumSalesInc.com, (888) VAC-UNIT (822-8648).** (PBM)

600 gallon carbon steel vacuum tank by Lely. Manufactured 9/2006, used off and on 2 years. Single compartment. Sight glasses, 2 top hatches, moisture trap, 4" & 3" openings. Great shape. \$3,900. 919-673-1977. (P10)

Presvac 2,800 US gallon aluminum tank only. (Stock #7959C) **www.VacuumSalesInc.com, (888) VAC-UNIT (822-8648).** (PBM)

## TANK TRAILER

1984 McKenzie 6,700 gallon tank trailer with Honda 3" trash pump, 4" rear discharge. \$6,000. Call John 610-705-5555 or les@pottyqueen.com. (P10)

NEW Presvac 5500 gallon c/s DOT certified vacuum tank trailer unit, with a PV750 pump, Deutz diesel. (Stock #13373) **www.VacuumSalesInc.com, (888) VAC-UNIT (822-8648).** (PBM)

## TOOLS

**T&T Tools:** Probes, Hooks. Probes feature steel shafts with threaded and hardened tips. The insulated **Mighty Probe™** tested to 50,000 volts. **Top Poppers™** open manhole covers easily. Free catalog. **www.TandTtools.com.** Phone **800-521-6893.** (CPBM)

**Crust Busters** - Portable, lightweight machine guaranteed to mix up septic tanks and grease traps! Save time and money! **www.crustbusters.com,** 1-888-878-2296. (PBM)

## TOYS

Septic pumper and vacuum die-cast toy trucks in your choice of colors and logos. Several cabs available. Call 877-450-2100, write to Granite State Collectibles, PO Box 440, New Ipswich, NH 03071; or **www.granitestatecollectibles.com.** (PBM)

## TRAILERS VACUUM/TANKER

2007 FMI Workmate Jr. Service Trailer w/slide-in tank. 325 gal. 7100# GVWR 2 toilet deck. Twin 5400# large brake axles. NEVER USED! Many extras. \$15,000. 843-338-1826. (P12)

## TRUCKS, MISC.

1996 International 9200 sleeper tractor, 10-speed Spicer transmission, 682,000 miles, Detroit 12.7 liter engine, drum pump, \$6,000. Call John 610-705-5555 or les@pottyqueen.com. (P10)

1984 Autocar Conventional tractor, 511,000 miles, 3406 DI 400 Cat, 13 speed transmission, tag axle. \$30,000. Call JD at 775-825-1595, email [jd@watersvacuum.com](mailto:jd@watersvacuum.com). (P10)

## TV INSPECTION

Van is a 2007 Diesel Sprinter Mercedes - 71000 km. EnviroSight built unit with: 125 Rowver (includes large diameter inspection kit), an RC 90 camera head, Back Eye reverse camera, and a RA 200 cable reel. Capable of shooting 150mm - 750mm. System powered by a 5.5 Super ONAN Equinox Inverter. \$140,000. For more information or to set up a viewing please email [mmeyer@dfi.ca](mailto:mmeyer@dfi.ca) (P10)

**WHY BUY NEW?** Standard Equipment Company sells and rents used and reconditioned sewer inspection camera systems. **www.standardequipment.com** or call Joe 312-706-9678. (P10)

2002 Ford E-450 Cube Van, V-10, 57,500 miles, Onan generator, Omni III Camera pan/tilt with zoom, dual monitor, POSM software. \$60,000. Call JD at 775-825-1595 or [jd@watersvacuum.com](mailto:jd@watersvacuum.com) for photos. (P10)

## TV INSPECTION

**WE BUY USED!** Sewer inspection camera systems and components, all makes and models, old or late model. Call Tom 312-706-9636. (P10)

## VACUUM LOADERS

1998 GAPVAX vacuum truck, 28" HG @ 5300 cfm blower w/3,400 hrs., VOLVO chassis with 100,000 miles. \$50,000. 207-854-9360, Wayne or Bill. (P10)

1999 International **heavy spec** with **Guzzler ace** wet/dry industrial vacuum loader. 8" top load boom truck is in excellent condition! (Stock #7390V) **www.VacuumSalesInc.com, (888) VAC-UNIT (822-8648).** (PBM)

1998 Guzzler/Ford Ace wet/dry, 5,500 cfm, 27" blower with full open rear door and offloading pump. Clean truck. KLM Companies, 617-909-9044. (P10)

2008 Demo Internationals 7600 with Guzzler Ace XXS4118TS wet/dry industrial vacuum loaders, 18-yd. debris bodies, dump-type, carbon steel vacuum tanks. **Demo/rental units.** (Stock #'s 4400V & 4401V) **www.VacuumSalesInc.com, (888) VAC-UNIT (822-8648).** (PBM)

## VANES

American Industrial Components: Our vanes are manufactured from the highest quality laminated materials available and are fabricated to exact tolerances and specifications. 800-272-7557. (PBM)

Dura Comp 535, high-quality non asbestos vacuum pump vanes. Good to 400°F. Buy factory direct and save. Same day shipment on most models. Jurop, Battioni, Moro, Masport, Fruitland, Demag. Long lasting Dura-Comp 535 pump vanes carry a "Money-back" guarantee. Call us today. Powerflo Products 800-758-4788 or 562-997-0720. (PBM)

## WANTED

WANTED: Used ADA handicap portable restrooms. Located in Southern California. Contact Warren at 760-290-3306; [warrenvd@diamondprovides.com](mailto:warrenvd@diamondprovides.com). (P10)

Looking for a portable restroom trailer. 2-stall trailer with urinal - Porta Lisa or like make. Needs A/C. Contact: [stevetxcz@aol.com](mailto:stevetxcz@aol.com). (P11)

Very serious and well qualified buyer looking for sewer, septic or industrial business in Dallas, Texas area. Must be grossing between \$500,000-\$1,000,000. All inquiries are kept confidential. Call Jeff at 800-257-7222. (PBM)

Wanted to Buy: Vactor 2100s and late model Guzzlers. Cash. Phone 800-336-4369. (CPBM)

**WANTED TO BUY:** Any make/model GapVax trucks you are wanting to sell. Call 888-442-7829 or email [inquiry@gapvax.com](mailto:inquiry@gapvax.com). (P10)

## WATERBLASTING

WATER JETTING EQUIPMENT. We sell, repair and retrofit water blasters. Visit us at: [www.waterjettingequipment.com](http://www.waterjettingequipment.com) or phone 714-259-7700. (P10)

2004 NLB 40-150 electric, 40,000 psi waterblaster, (0) hours on unit - never used. Marathon Motor on skid with control panel. KLM Companies, 617-909-9044. (P10)

**Gardner Denver** T-450M w/Series 40 Detroit 10K 39GPM. **Jetstream** 4215 w/ Cummins 10K @ 39GPM. **Gardner Denver** TX-450SB w/V12-71 Detroit 10K @ 70GPM. **Gardner Denver** T-450 w/ Jetstream fluid end transmission 10K @ 40GPM. **THE-500UH** 50K bareshaft pump. **NLB** 10-600 Cummins 10K @ 104GPM. Boatman Ind. 713-641-6006. View @ [www.boatmanind.com](http://www.boatmanind.com). (CPBM)

It's **EASY** to submit your classified **ONLINE!**

Just go to: [www.pumper.com](http://www.pumper.com)  
Place a Classified Ad;  
Fill in the Online Form!

PLACE YOUR AD ONLINE AT [www.pumper.com](http://www.pumper.com) - IT'S ALWAYS THERE TO MEET YOUR BUSY SCHEDULE

# POLYLOK™ Inc.

Innovations in Precast, Drainage  
& Wastewater Products



Zabel®  
A Division of Polylok Inc.

# WE HAVE IT ALL!

## New Products



Gravity Effluent Filters



Septic Tank Risers

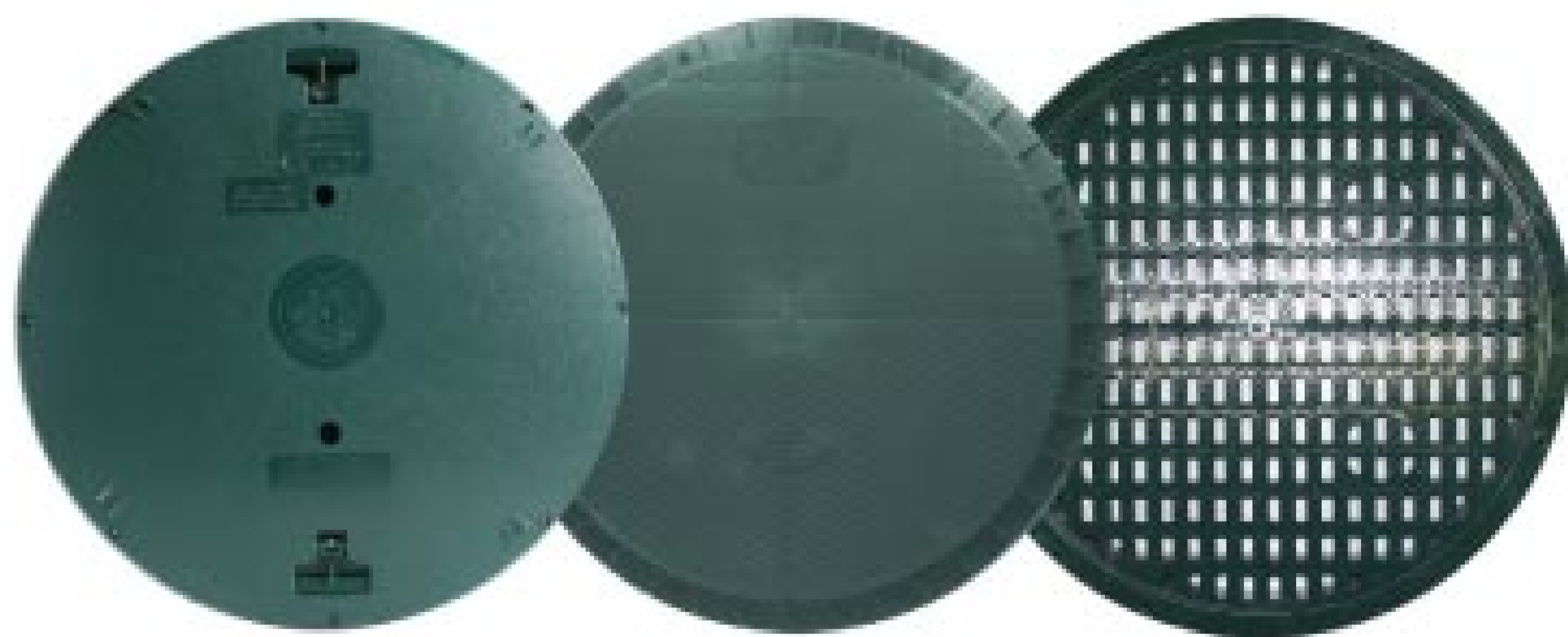

Riser Covers, Heavy Duty Covers & Grates



Decorative Landscape Stones



Poly-Cleanse /  
Polylok Prep & Clean  
(Waste Digesting Bacteria)



18" & 24" Heavy Duty  
Covers and Grates

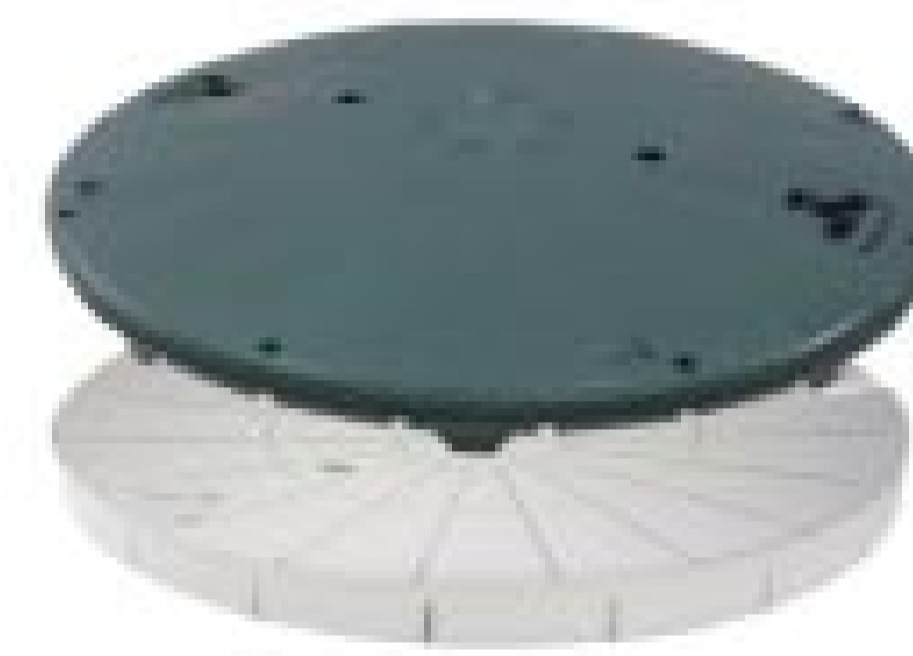

Insulation for Polylok's  
20", 24" & 24"  
Heavy Duty Covers



Air Pumps

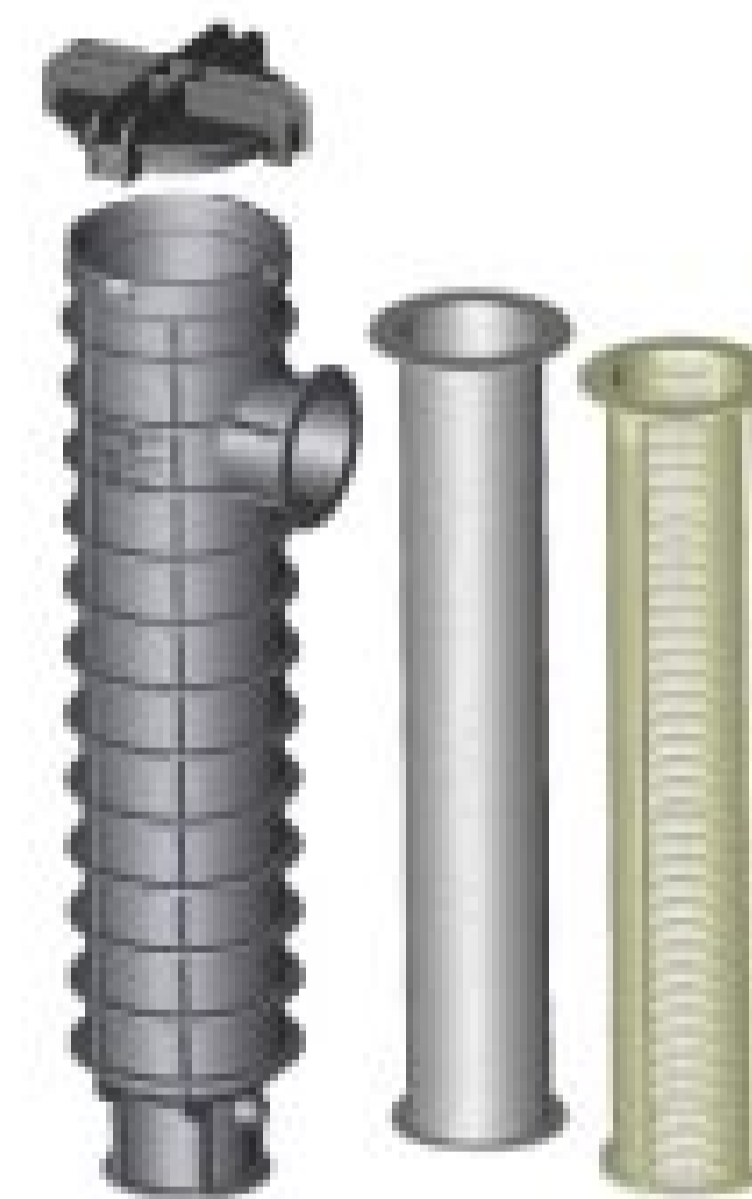

High Pressure Filter



U.V. Disinfection Unit



Poly-Air  
(Activated Carbon Vent Covers)  
4", 3", 2" & 1.5"



Activated Carbon  
Vented Covers  
18", 20" & 24"

1.800.701.3942 / [www.polylok.com](http://www.polylok.com)

Your One Stop Shop for Superior  
Onsite Wastewater Products.

# How a plastic recycling program can help portable restroom operators save the world – and some money

It's not often that a company can save money and positively impact the lives of every human being on the planet at the same time. We recently had the opportunity to learn about a program that will do just that. **PolyJohn Enterprises is launching the first-ever portable sanitation recycling program** in effort to 'close the loop' on the plastic portable restrooms that are manufactured throughout the industry. In a recent interview with PolyJohn's Managing Director, Mike Adams, we learned about the details of this innovative new program.

**Interviewer:** Recycling plastic has been done for a long time. Why has it taken the portable restroom industry so long to get onboard?

**Adams:** Well, it's not that we've been reluctant to get onboard – it's just that we are presented with a very different recycling challenge because of the type of plastic we use in making portable restrooms and the type of wear and exposure our plastic goes through. A plastic milk carton or a plastic bottle lives a life that is very different than a portable restroom! Plus, the plastic materials in those products are very different from the High-Density Polyethylene (HDPE) material used in portable toilets. Although PolyJohn and other plastics manufacturers have been recycling scrap HDPE generated from our own manufacturing processes for years, the challenge for PolyJohn has been finding a way to process the HDPE plastic from used restrooms.

**Interviewer:** What has made recycling used portable restrooms so challenging?

**Adams:** As you can probably guess, there are many reasons this has been a challenge! For one thing, the material from used units may contain HDPE that is up to 20 years old. During that time, the units were out in the field and subject to all sorts of weather conditions and the chemicals that are used

in the cleaning and servicing process. That can make it difficult to ensure that the quality of the material made from that recycled plastic has the same properties as products made from virgin plastic. These factors, along with the sheer logistics of moving restrooms to recycling equipment, have kept manufacturers from recycling used toilets.

**Interviewer:** So, how does PolyJohn's Recycling Program overcome these issues and help operators get their toilets recycled?

**Adams:** First off, our engineering team was able to develop a process that makes recycling the HDPE in used toilets possible. We've run a large number of tests on a variety of units without any problems. **To show operators what's possible, we're launching a pilot program out of our Whiting plant before we begin accepting units at our regional distribution centers.** Operators can find all the details about drop-off at Whiting on our website, and will receive a \$35 Recycling Rewards coupon to be used toward a new restroom or sink for each unit they bring in to be recycled.

**Interviewer:** How does PolyJohn plan to use the recycled HDPE from the used toilets?

**Adams:** Because of the length of time our restrooms last in the field, which can be anywhere from 15 to 20 years, we will not risk using the materials we take in from used restrooms to make side panels, roofs, etc. After extensive testing, however, we have discovered that with some new additives that are now available, we can easily make floor sheet and possibly even mix the recycled restroom material with virgin materials to make our large holding tanks and the like. If we can't use the recycled restroom material after it is mixed at our Whiting facility, we do feel it will be suitable for various uses outside

our industry and have some value on the open market.

**Interviewer:** It must feel good to be able to offer such a program to your customers.

**Adams:** I have to say that there very few things I have done in my thirty plus years in the sanitation industry that I have felt as proud of as this program. **It is just the right thing to do.** We believe our customers – and the rest of the industry as a whole – will feel the same.

**Interviewer:** How can folks learn more about this program?

**Adams:** Just visit our web site at [www.polyjohn.com](http://www.polyjohn.com). All the information about prepping used units and where to send them are posted on link from there.

## Why is it The Right Thing To Do Environmentally?

Recycling 1 ton of plastic saves 7.4 cubic yards of landfill space. If we recycle 125,000 units over ten years, that means we will have prevented 18,038 garbage truck loads of plastic from being put into landfills.

## And Economically?

If you recycle 50 units, you save \$275 over the cost of straight disposal plus you earn \$1,750 worth of Recycling Rewards Coupons good toward the purchase of new PolyJohn products. **Your net gain total is \$2,025!**



**Find out More at [PolyJohn.com](http://PolyJohn.com)!**  
**800-292-1305**

# **PRESVAC**

DESIGNED AND BUILT FOR PERFORMANCE

## **BRIGHT FINISH ALUMINUM TANKS**

for the Septic Pumping Industry...  
Standard tank models from  
2,000 gallons to 5,000 gallons.



## **HYDRO-TRENCHER**

5300 CFM air flow/28" HG vacuum with 8" hydraulic actuated boom, 3000 U.S. gal. stainless debris tank, 1000 U.S. gal. stainless water tank, 9 G.P.M. water pump with pressures to 5800 p.s.i.

## **POWERVAC 5300 FOR WET/DRY OPERATION**

5300 CFM air flow/28" HG vacuum,  
Dump chutes extended to rear of truck,  
Stainless steel 316, DOT 407/412



## **LIQUID TRUCK - DOT 407/412**

Designed for industrial liquid applications

**PRESVAC**

4131 Morris Drive  
Burlington, Ontario, Canada L7L 5L5  
Fax: 905-681-0411

**NATIONWIDE SALES & SERVICE**

**905-637-2353 • 800-387-7763**

**www.presvac.com**