

VACUUM TRUCKS & TRAILERS

DEDICATED TO THE LIQUID WASTE INDUSTRY

Pumper

August 2009 www.pumper.com \$5.00 U.S.

Answering the Call

John's Septic adapts to new demands

PAGE 36



A Winning SMILE

PAGE 28

Happy face logo, TV ads help market Total Septic

CHANGE SERVICE REQUESTED

PAID
U.S. POSTAGE
PSNSTD STD
COLE PUBLISHING

COLE PUBLISHING INC.
1720 MAPLE LAKE DAM RD., PO BOX 220
THREE LAKES WI 54982



There's Always Something New!



WWW.SATELLITEINDUSTRIES.COM

Visit us online for the latest news and special promotions!

HEADLINE NEWS at Satellite Industries



SATELLITE GOES GLOBAL

With the addition of the Global, Satellite can now service the portable sanitation industry with a low priced leader.



[Read More...](#)

[PREMIUM PRODUCT DISCOUNTS](#) [click here](#)

WWW.SATELLITEINDUSTRIES.COM

800-328-3332

Masport®

"Quality Vacuum Pumps & Components"

Air Cooled & Liquid Cooled Vacuum Pumps & Systems

Robuschi Blower Systems

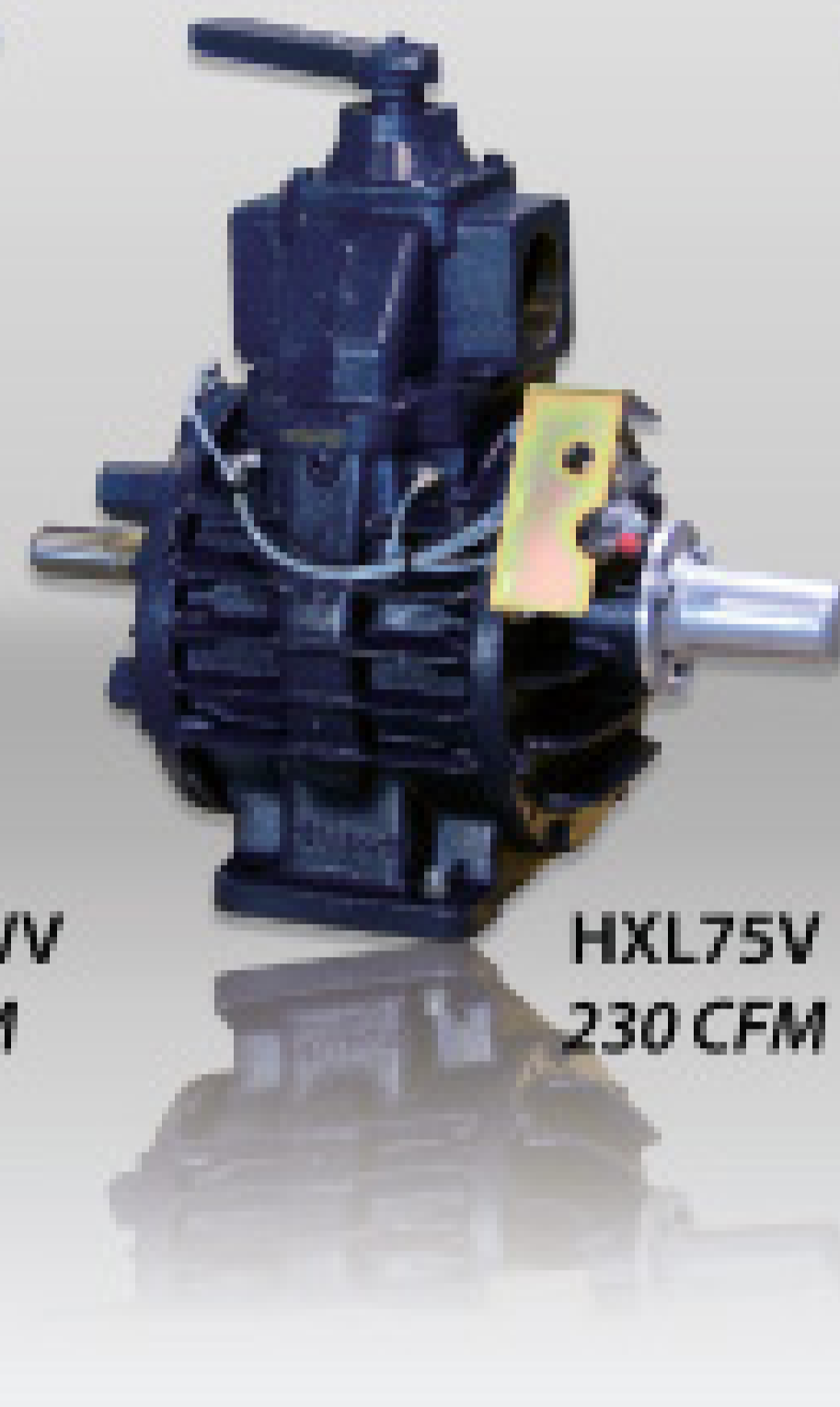

Masport Manway



Low Profile Primary



Inlet Filter



Horizontal Scrubber



Vertical Scrubber



Engine Driven Systems between 5.5 & 24 HP

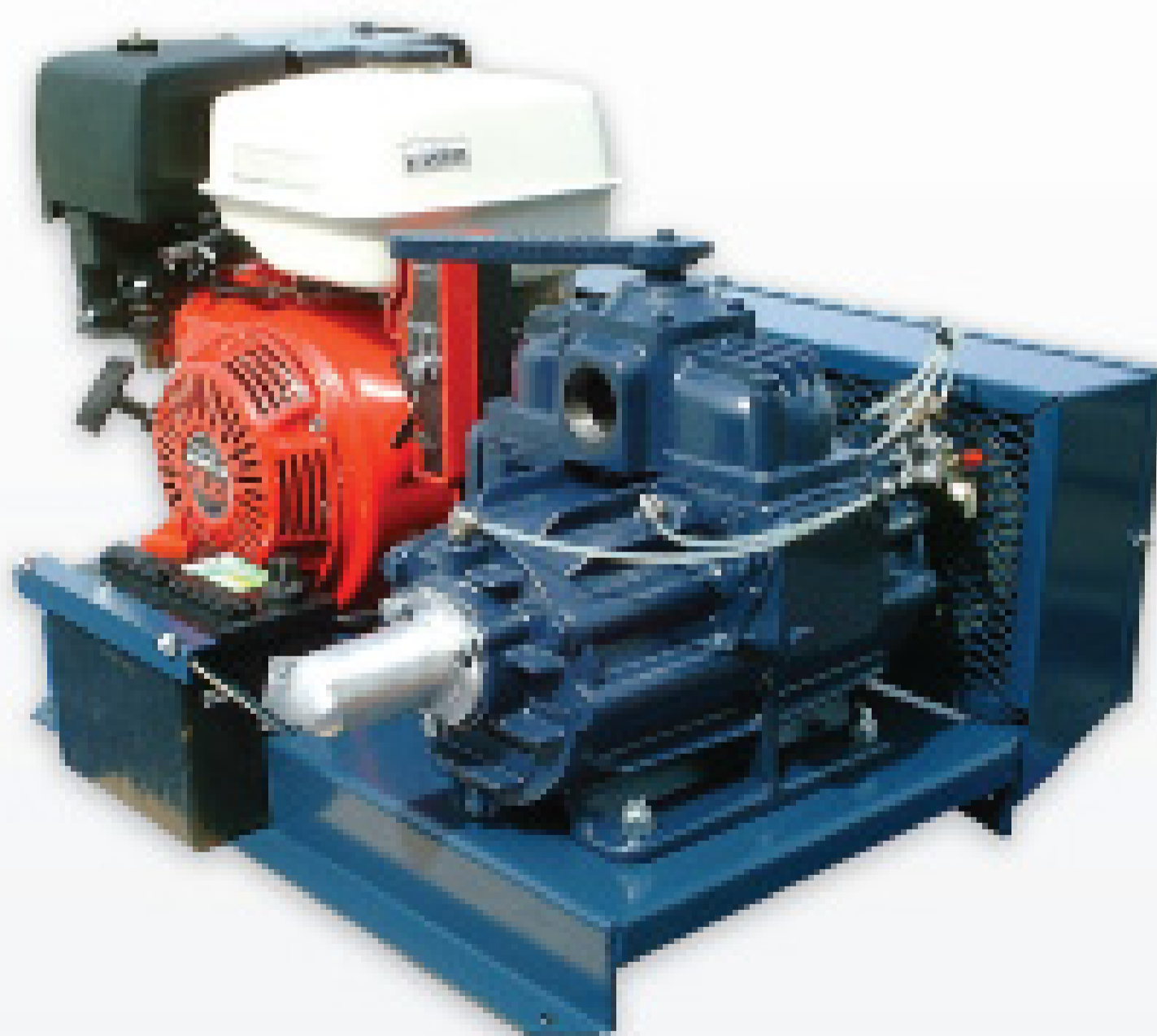

Vacuum & Pressure Relief Valves



Oil Separator



Masport Oil



Products That Improve Your Bottom Line.

To find an authorized Masport dealer in your area,
call toll free 1-800-228-4510.

Visit us online at
www.masportpump.com

Ask us how the Sanitation Station can make you **money.**

Capital Outlay =

Sanitation Station is a Commercial Quality Running Water Restroom great for construction projects that can:

- Boost your cash flow immediately
- Allow you to have No out of pocket expense
- Be moved throughout the jobsite to meet the manpower requirements
- We provide the Marketing Material & Sales Assistance

Once these units are on the Jobsite the revenue stream starts flowing...

DROP BOX Custom Modification Specialist

888-388-7768 • 740-532-7822
www.dropboxinc.com
rmitchell@dropboxinc.com

Reading Between the Lines

Is the *Classy Truck* in Your Yard?

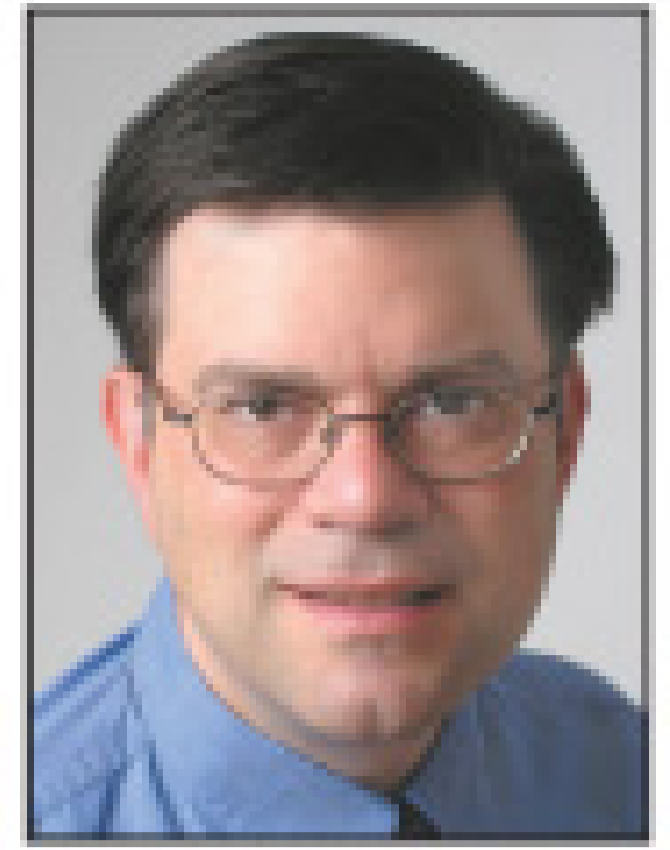

By Jim Kneiszel, Editor

A few weeks ago, the phone rang and I picked it up. "Hello, this is (so and so) from (such and such) Pumping in (insert city and state here)," the male caller said. "I want to find out where to send a *Classy Truck* picture because I have this year's winner parked in my yard."

"Well," I replied, "you sound pretty confident in your rig's chances, but there are a lot of pumpers who would probably take issue with you." "Really? Like whom?" the incredulous caller said. "I'll put my truck up against any of them." Then he promised to send me the digital photo real soon and asked that I keep a page open for his winning truck.

I love *Classy Truck* owners and I love the feature. Service trucks are a great source of pride in this industry, and I had to chuckle at the thought of getting this gung-ho fella sitting around a conference table with the rest of 2009's *Classy Truck* owners arguing over who has the best truck.

WINNING WAYS

What would each of these gearhead pumpers say is the feature that most defines a *Classy Truck*? For some, I'm sure it's the big and beefy Peterbilt, Mack or Kenworth chassis that cradles their moneymaking vacuum equipment. Others might say a certain pump/tank configuration should play into our annual contest winner. Still other pumpers would subscribe the *Pimp My Ride* style of service vehicle, favoring the rig with the most chrome, glowing underbody lighting or wild custom interiors. We've seen it all — elaborate flame paint jobs, small tanks on big trucks, old-school restorations and new trucks fresh from the builder.

So how are the collection of monthly *Classy Truck* entries judged to choose the annual winner? The selection is based on the combination of a reader poll at the end of the year and an office vote of the crew here at *Pumper*. Some folks vote strictly on looks, others on functionality. Often the winner exhibits a combination of both a great paint job and carefully chosen components to build a truck that is both an effective promotional and working tool for its owner.

WHAT'S IN YOUR GARAGE?

I'd love to see more *Classy Trucks* join the competition. The next time you wash your rig at the end of a busy day, I invite you to snap a photo of the truck and send it to me at editor@pumper.com. In the e-mail, jot down the features that you think make your truck a *Classy Truck*.

Oftentimes, pumpers tell me they've always wanted to enter their rig in the *Classy Truck* contest, but busy schedules never seem to let them get around to it. I'd argue there's no time like the present to take a few moments and put your truck up against the industry's best. Like our confident caller said at the top of this column, you might have this year's winner parked in your yard. ■

Contact us: Pumper strives to serve the liquid waste industry with interesting and helpful stories. We welcome your comments, questions and column suggestions and promise a prompt reply to all reader contacts. Call 800/257-7222; fax 715/546-3786; e-mail Pumper editor Jim Kneiszel at editor@pumper.com.

Lenzyme
Solutions for all Waste & Grease Problems

Simple Solution for Your Customer's Sluggish System

NEW ONE SHOT PLUS

BEST PACKAGING - BEST PRODUCTS - BEST PRICE

Discover Marketing Secrets to More Pump-Outs

1-800-223-3083
Call Today for Your **FREE** Sample

ROOTX

Trap-Cleer Lenzyme

HOUSE OF IMPORTS TRUCK SALES

WWW.HOUSE-OF-IMPORTS.COM

CALL ANGEL AT:
786.258.3384
OR
305.691.4778

FAIR PRICE, QUALITY, CRAFTSMANSHIP & SERVICE!



2002 WESTERN STAR
THANK YOU TO JOE COSTULAS



READY FOR
IMMEDIATE
DELIVERY

2005 PETERBILT 335
3600 GAL, DUMP SYSTEM
FULL LOCKERS REARS, 167K ORIG. MILES



2006 MACK GRANITE
THANKS TO JOHN POWELL



2002 INTERNATIONAL
THANK YOU TO MR. PITA - SOLD TO EXPORT

**100,000 MILE LIMITED
FACTORY WARRANTY**

DELIVERY ▶ EXPORT ▶ PUMP WARRANTY: 1 YEAR ▶ TANK WARRANTY: 5 YEARS

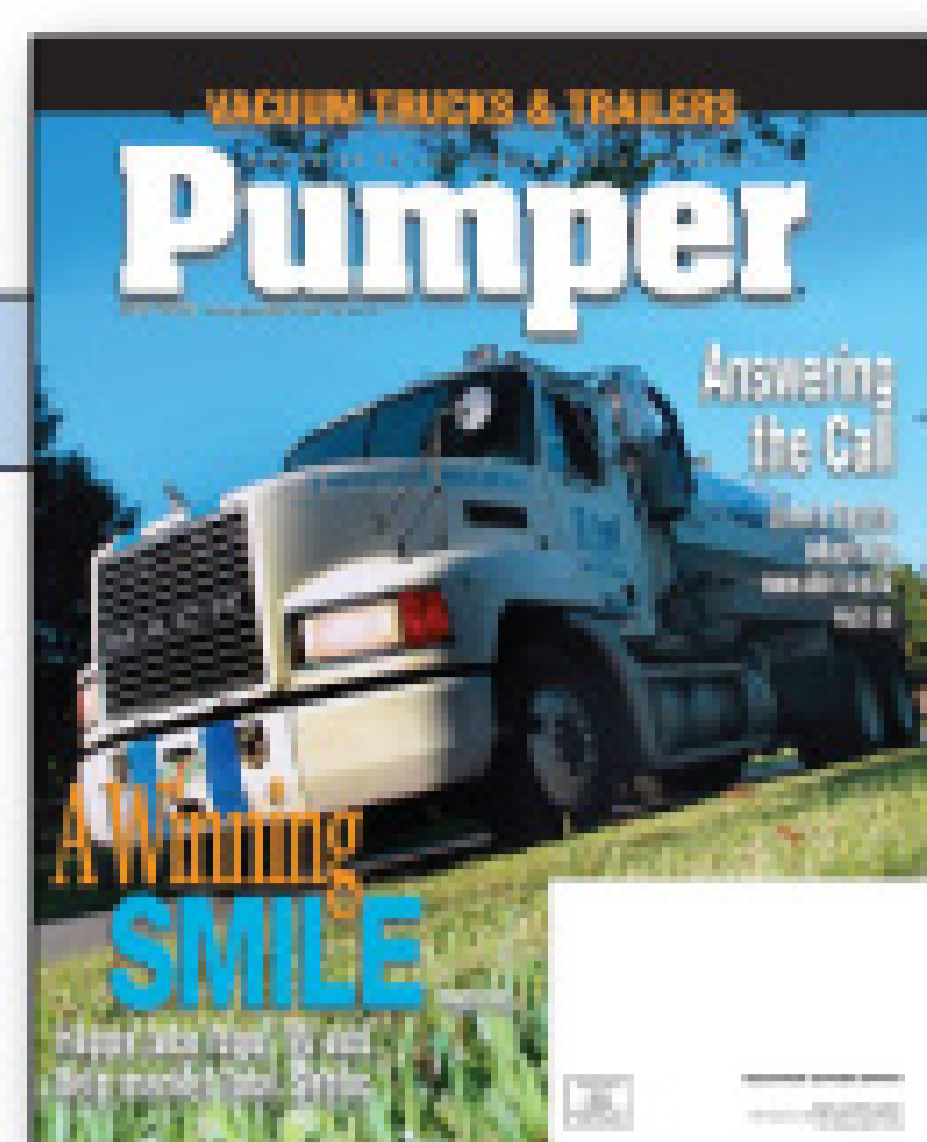

ARTICLES

28
A Winning Smile
- Ken Wysocky

On the cover: Florida's Total Septic uses a happy face logo and television advertising to drive home the company message of do-it-all customer service. On the cover, one of Total Septic's pumping rigs on an early morning run. (Photo by Ed Wodalski)

4
**Reading Between the Lines:
Is the Classy Truck in Your Yard?**
- Jim Kneiszel

10
Letter to the Editor

16
**Building the Business:
File or Pile?**
Follow these six steps to better paperwork organization and you'll soon break free from menacing office clutter.
- Christy Youd

22
**Rules and Regs:
Regulator Clarifies Ohio Onsite Rule Proposal**
- Scottie Dayton

36
Answering the Call
An industrious family celebrates 40 years of pumping tanks and making friends in their Maryland hometown.
- Ken Wysocky

44
**Pump Roundup:
Primed For Action**
Vacuum pump manufacturers offer latest innovations to improve efficiency and performance.
- Ed Wodalski

52
**Overheard Online:
Propane Pump Tank Looks Tempting**
But posters caution a waste hauler to consider all the problems recycling a 1,000-gallon fuel tank might pose to safe truck operation.

56
Fall Truck Maintenance: Pull'er in the Garage
As summer gives way to fall, it's time to make sure your fleet is prepped to handle cold-weather challenges.
- Robert E. Carlson

64
**Pumper Interview:
The Future of Private Waste Processing**
As Orlando's Select Processing prepares to host the 2009 NAWT Waste Treatment Symposium, company president Steve Macchio talks about treating waste for pumpers.
- Scottie Dayton

REGULAR FEATURES

60
Industry News

67
**NAWT News:
Expect More Maintenance, Buy and Sell
Inspection Requirements**
- Tom Ferrero

70
**Reader Pipelines:
Truck Size Matters**
A variety of factors help pumpers determine the size of a new vacuum rig.
- Mary Shafer

76
**Septic System Answer Man:
Stop Short on Trenches?**
More research is needed to determine whether new distribution media products require smaller drainfields.
- Roger E. Machmeier, Ph.D.

80
Money Manager: Getting Credit
Maintain a good credit rating and you'll still find financing at a time when money's tight.
- Erik Gunn

84
Classy Truck of the Month
We feature Ronnie's Septic Tank Service Inc., Brewster, N.Y.

86
**Product News — In the Spotlight: BDP Industries
3DP Belt Press Filter**

90
**Association News; Training and Education;
Calendar**

Coming in September

- Special Issue: INDUSTRIAL VACUUM LOADING**
- Pumper Interview: Are you equipped to be a system inspector?
 - Contractor Profile: North Carolina contractor thrives on tough jobs

Pumper

DEDICATED TO THE LIQUID WASTE INDUSTRY

www.pumper.com

Published monthly by

COLE publishing
Celebrating 30 years of publishing.
1979-2009

COLE Publishing Inc.
1720 Maple Lake Dam Rd.
PO Box 220
Three Lakes WI 54562

© Copyright 2009 COLE Publishing Inc.
No part may be reproduced without
permission of the publisher

In U.S. or Canada call toll-free 800-257-7222
Elsewhere call 715-546-3346
E-mail: info@pumper.com
Web site: <http://www.pumper.com>
Fax: 715-546-3786

Office hours 7:30 a.m. - 5:00 p.m.
Central Time, Monday - Friday

SUBSCRIPTION INFORMATION: A one year (12 issue) subscription to *Pumper* in the contiguous 48 U.S. states costs \$16 (24 issues for \$26; 36 issues for \$36). Subscriptions to Canada or Mexico cost \$28 per year (24 issues for \$54). Subscriptions to all other foreign countries cost \$82 per year. Subscribers are guaranteed monthly delivery of the magazine. To subscribe, send company name, mailing address, phone number and check or money order (U.S. funds payable to COLE Publishing Inc.) to the address above. MasterCard, VISA and Discover are also accepted. Supply credit card information with your subscription order.

Our subscriber list is occasionally made available to carefully selected companies whose products or services may be of interest to you. Your privacy is important to us. If you prefer not to be a part of these lists, please contact Kayla at kaylaw@colepublishing.com.

CLASSIFIED ADVERTISING: RATE: \$1.00 per word, per month. Minimum of 20 words or \$20. All classified advertising must be PAID IN ADVANCE. **DEADLINE:** Classifieds must be received by the tenth of the month for insertion in the next month's edition. **PHONE-IN ADS ARE NOT ACCEPTED.** Ads may be faxed only when charging to MasterCard, VISA or Discover. Please supply all credit card information with faxed ads. Be sure to include your phone number (with area code) in your ad. Make checks payable to COLE Publishing Inc. and mail with classified ad to the address above. **CLASSIFIED ADVERTISING APPEARS NATIONWIDE AND ON THE INTERNET.** Not responsible for errors beyond first insertion.

DISPLAY ADVERTISING: Call 800-994-7990 and ask for Jim, Kim, Winnie or Phil. Publisher reserves the right to reject advertising, which in its opinion is misleading, unfair or incompatible with the character of the publication.

CIRCULATION: Circulation averages 26,071 copies per month. This figure includes all circulation regions (nationwide) and international distribution.



**PUMPER & CLEANER
ENVIRONMENTAL
EXPO
INTERNATIONAL**

Education Day:
February 24, 2010

Exhibits Open:
February 25-27, 2010

Kentucky Exposition
Center
Louisville, Kentucky
www.pumpershow.com



moroPUMPS

"Over 50 years of service and here to stay!"

Ask for a quality Moro pump from your truck builder, or call us for the dealer nearest you.

Pittsburgh, PA . 1-800-383-6304 . fax 412-269-4172 . www.morousaeast.com . moroeast@attglobal.net
St. Louis, MO . 1-866-383-6304, 636.584.8844 . fax 636-583-2044 . www.morousaeast.com . moro@charter.net

The **NEW** Moro Vacuum Pumps from **MORO USA**



PM60A

233 cfm

PM70A

300 cfm

PM80

379 cfm

Isn't it time to UPGRADE to a MORO?

Complete Right Angle Packages

Pumps available from 176-1642 cfm

Completely Assembled



230 cfm

M10



PM80

350 cfm



460 cfm

PM100

DC-STAINLESS Washdown Pump

NO COMPARISON



NO more RUSTY water!

OUTPERFORMS the Burk's cast iron DC-10!

NO More FROZEN pump!



316 Stainless Steel Mounting Brackets, Pump Head & Impeller

Quality RIV Components In Stock — Ready for Shipment



ACCU-LEVEL

Accurate Tank Volume Measurement

No Balls • No Tubes • No Floats • No Worry!
No Internal Tank Components

Get paid for what you pump!

Only pay for what you dump!



Level Indicator

Factory calibrated, the general purpose indicator reads 0-100% of volume in gallons. A single push button allows users to scroll through their active channels.



Pick-up Unit

The general purpose two-wire transmitter provides non-contact level measurement up to 32' and is ideally suited for challenging corrosive, coating or waste liquids.

ADVERTISER index

August 2009

A

 Abbott Rubber Co. Inc.12

 Abernethy Welding & Repair 60

 Acro Trailer Company83

Agribusiness Supply Co.40
Allied Forward Motion LLC....57
American Machine & Tool50
Amthor International.....68
Anchor Graphics Inc.57
Aqua Ben Corp.60

 Aqua-Zyme Disposal Sys.....72

 Arcan Enterprises Inc.50

 ARMAL Inc.59

 Armstrong Equip.13, 40, 62

Art's Truck & Equipment.....83
Atlanta Rubber & Hyd.54

B

Badger Vacuum Trucks.....91
Baker's Waste Equipment....34
Bandlock Corp.....34
Best Enterprises Inc.47
Black Tie Manufacturing17
Brenlin Co. Inc.....18

 Bright Technologies71

C

Cam Spray40
Cape Cod Biochemical10

 Capital Rubber Corp.31
Center Capital Corp.26

C

 Chandler Equipment Inc. 9, 11
Chempace Corporation60

 Clear Computing Inc.84

 Comforts of Home Services 57

 Crust Busters/Schmitz Bros...87

 Cusco Fabricators.....46

D

Denver Truck Sales.....81
Dragon Products27
DropBox Inc.4
Dultmeier Sales24
Dyna Vac Equipment68

E

Ecological Laboratories89

 Elastec/American Marine26
EnviroTub20
Erickson Tank & Pump82

F

 F. S. Solutions.....49
Fergus Power Pump Inc.65

 Flo Trend Inc.43
Fruitland Tool & Mfg.72

G

GapVax Inc.75
Glendale Welding20
Granite Leasing Co.78
Green Way by PolyPortables 35
Guzzler Manufacturing Inc...61

H

Hannay Reels88
House of Imports5

I

Imperial Industries Inc.23

J

 J&J Chemical Co.77

 JAG Mobile Solutions89

K

KeeVac Industries Inc.32
Kentucky Tank Inc.62
Key Commercial Corp.18
Kuriyama of America88

L

L.C. Tanks.....78
L.M.T. Inc.24
Lane's Vacuum Tank Inc.31

 Lely Manufacturing Inc.18
Lely Waste Solutions58

 Lenzyme-Trap-Clear Inc.....4
Longhorn Tank & Trailer87

M

Magnets by Stamp Works ..17
 Marsh Industrial50

 Masport Inc.3
McKee Technologies Inc.55
Michigan Vacuum Truck48
Mid-Continent Truck Sales ..99
Mid-State Tank Co. Inc.78
Milwaukee Rubber Prod.20

 Moro USA East Inc.7

N

National Vacuum Equip.46
NAWT Inc.79
NuConcepts22
Nuhn Industries LTD.....79

P

 Pik Rite Inc.74
PolyJohn Enterprises107
Polylok Inc.....106
PolyPortables Inc.....14-15
Power Vac Inc.22

 Pressure Lift Corp.58
Presvac Systems Ltd.....108

 Prototek Corp.65

R

RA Ross N.E.42
Robinson Septic Service43
RotoSolutions Inc.81
Rush Refuse Systems73

S

Satellite Industries Inc.2, 81

 Septic Services Inc.74
Smithco Mfg. Inc.....54
Specialty B Sales32
Surco Products.....17
Sweet Septic Systems Inc.43

T

 T&T Tools Inc.42
Tank Truck Service & Sales 89

 TankTec.....41
The Service Program52

 Toico Industries Inc.82

 Transport Truck Sales63

 Transway Systems Inc.....53
TSF Company Inc.21
TST, LLC.....48
Tuf-Tite Inc.25

V

V.E. Enterprises Inc.88
Vac-Con Inc.....39
Vacutrux Limited55

 VAR Co.19

W

Walex Products Co.69
Wallenstein Pumps-Elmira ..55
Water Cannon Inc.51
Wee Engineer Inc.12

 Wells Cargo COG71
Westmoor Ltd.33
Wilcox Truck Sales65

Classifieds100
Marketplace92
Truck Stop94

REGIONAL ADVERTISERS

Midwest Supplement

(after page 66)

Advance Pump & Equip.3
Engle Fabrication LLC8
Heritage Truck Equipment6
Liberty Financial Group4
Marengo Fabricated Steel5
Milwaukee Rubber.....2
Pat's Pump & Blower4
Pierson Co.2
T-Line Equipment Inc.6
V&H Inc.8
Vacuum Sales Inc.....7

Eastern Supplement

(after page 66)

Advance Pump & Equip.....3
Andert Inc.....2
Collar City Auctions Realty ..6
Heritage Truck Equipment6
Liberty Financial Group4
Manchester Hose & Coupling ..2
Marengo Fabricated Steel5
Pat's Pump & Blower4
TSI Tank Services Inc.....8
V&H Inc.8
Vacuum Sales Inc.....1, 7

1.800.342.0887
www.chandlerequipment.com



R260 Vacuum Pump
364 CFM | Air cooled



LC300 Contender
300 CFM | Liquid cooled

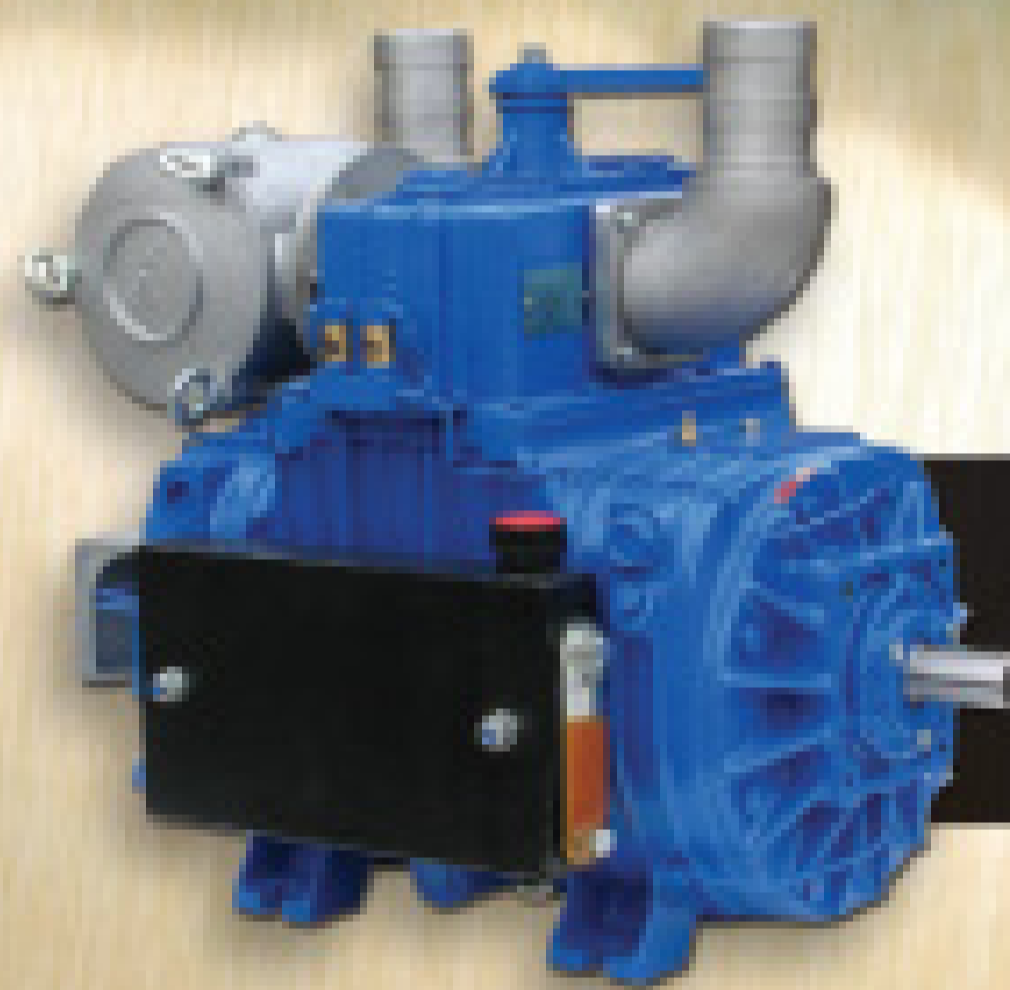

LC420 Contender
425 CFM | Liquid cooled



PVT200 Tri-Lobe Blower
795 CFM | Air cooled

Chandler Equipment makes sure you have everything you need to get the job done. With pumps like the Jurop R260, LC300, and LC420, and the PVT200 blower, you'll have all the air flow you need.

FOR PUMPERS ONLY

SINCE 1976 WE HAVE BEEN DEALING ALMOST EXCLUSIVELY WITH PUMPERS. THAT'S WHY...

- Our products are formulated for the waste YOU are pumping
- Our sales brochures are geared toward septic system maintenance and stress pumping
- Our product application guide is organized by the jobs that YOU do every day.

Most companys' product application guides list their products and what those products will do. Our product application guide lists the jobs that YOU DO every day, and which of our products is the best product to use for those jobs.

APPLICATIONS	PRODUCT	SPECIAL APPLICATIONS
Residential & commercial septic system maintenance		To remove organic stains/odors
Drain/pipe buildup remover		To remove pet stains/odors
Drain field restoration		To clean organically stained carpets/upholstery
Commercial sewer line maintenance		To use as laundry presoak for feces/urine
Restaurant grease trap maintenance: manual		
Restaurant grease trap maintenance: automatic		
USDA facilities		EQUIPMENT APPLICATIONS
ATU's & Lagoons		To use in conjunction with soil fracturing
		To inject through jetter

In other words, we don't tell you what to do so you'll use our products. We tell you which of our products is the best tool to have in your tool box for what YOU are doing on the job... day in and day out.

That's why more pumpers use products from Cape Cod than any others. Because we aren't in the chemical business. We're in the PUMPER business. We're here to help you solve problems, not just to sell you products. We have more hands-on experience, and we're here for YOU...and only you...every day!

To find out more about our products and our program of "Better Business Through Customer Education", please call us toll-free at 800-759-2257. We'll send you our product info packet, including prices and educational brochures. No cost or obligation, and no obnoxious salesman will call you (a big plus with us). Please call today. Thank you.

—Rick Howe, President

GREEN PRODUCTS FOR SEPTIC PROFESSIONALS SINCE 1976

CAPE COD BIOCHEMICAL COMPANY

P.O. Box 990 • Pocasset, MA 02559



1-800-759-CCLS
(1-800-759-2257)

FAX: 508-564-9974 • www.SepticOnline.com

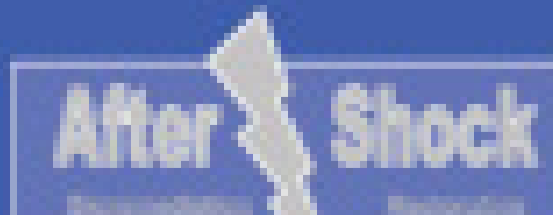

Letter to the Editor

Drainfield Detective Story Appreciated

To the Editor:

We have been out here for nine years, kicking, screaming, yelling about the subject of Zan Ewing's article in the May issue of *Pumper* titled, "Be a Drainfield Detective." Upon inspecting many septic systems, Ewing voiced the concern that "many septic systems have been replaced that were not failing ..."

When we first started American Septic Service, this is what gave us the jump-start in real estate inspecting before the practice became popular. A real estate agent was advised of a failed system she represented and, you guessed it, it had a severed pipe at the outlet delivery. A contractor started installing a new field (from the end of the field) and got to the tank to connect, and *whoops!*

I can't say it too many times: It all begins and ends with the tank — open it, work your way out. We also have a decade of tanks in Cochise County that have a T-baffle extension sitting within 8 inches of the bottom of the tank. The scenario goes like this: The pumper is called out, he pumps through the 4-inch inspection port, the tank backs up again shortly. The third time around, it is declared a drainfield problem and an installer is called. The issue was not the drainfield, but rather that sludge had risen too high and surrounded the outlet pipe so effluent could not leave the tank as fast as it was coming in. Open the tank, clean and pump it properly, and the problem is solved.

Ewing's article encouraged me that someone else sees the problem. I could tell, as I read the article, Ewing knows when a problem is caused at installation. There are classic discoveries. I call it when I see it that way, and the sanitarian has cautioned me not to give my opinion because the ground can settle. That is just plain false (I am being reserved in my language).

If the installer would follow the rules for compaction or undisturbed earth, there would not be the dipped, crimped, or severed deliveries. When you have a pool of sewage and black biomat goo, it is a no-brainer. I have done a study on 278 septic inspections (collating 50 points of discovery on our point-of-sale form) and 39 percent were baffle-related issues, most of them on newer installations where the baffles are not fixed in the tank casting.

As Ewing noted, most of these problems do not show up the first few months and sometimes for years. When the soil finally gets saturated at the end of the tank where the pipe is not performing, it backs up or the pipe gets occluded. However, this is not an extreme case here in Cochise County; we do one of these a week. Poor installation.

In our state, you cannot go back to the installer to fix a problem after a year has passed, which is frustrating. Our state has been criticized for having overlapping certifications for inspection, installation and design. Installers still are not listening. Thank you for the insightful article.

Dawn Long
American Septic Service
Sierra Vista, Ariz.



METALTECNICA s.r.l.

Dares are our job!

Cast iron valve with knife in stainless steel



USA DISTRIBUTOR



Toll Free 1-800-342-0887 - www.chandlerequipment.com



www.metaltecnicazanolo.com

HOSE ASSEMBLIES

MANUFACTURED TO YOUR EXACT HOSE REQUIREMENTS BY THE LEADING SOURCE IN HOSE FABRICATION.



**LOWEST PRICES
GUARANTEED
ON ALL OF OUR**

"QUICK-SHIP"

ITEMS

INCLUDING
HOSE & ASSEMBLIES
COUPLINGS • VALVES • ADAPTERS

300EPDM • 180AR • 180HR • 180BL
390SD • 220RS • GREEN PVC
KANALINE SR • KANAPOWER AT

Genuine

Kanaflex®

Assemblies by

ABBOTT

300EPDM HOSE NOW AVAILABLE IN COLORS

GREEN/BLACK - BLUE/BLACK - RED/BLACK

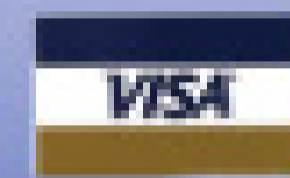

RUBBER COMPANY, INC.

1700 Nicholas Blvd. Elk Grove Village, IL 60007

www.pumperhose.com

1-800-852-1855 FAX: 847-952-0156

sales@pumperhose.com

Wee Engineer

WITH IMAGINATION

Call us for a quote...

WE

Reduced
\$110,875

2008 International 7400 MaxxForce DT, 300 HP, Allison 5-speed automatic, **New 3600-gallon Progress aluminum tank**, full length aluminum hose trays and a **New Masport HXL 400 CFM vacuum pump**, water-cooled.

Price**\$112,875.00 + FET**

2002 Freightliner

FLD112 410HP Cat

CT2, 10 speed Fuller, PS/AC, Air Ride, 395,000 miles **NEW 3500 gallon carbon steel tank** primary/secondary shut-offs, top & rear manway, sight glasses, hose trays, 3" inlet, 4" outlet with lever valves and camlocks. **New National Vacuum 367 Challenger pump** PTO and gearbox driven Price.....**\$58,925 + FET**

Price.....**\$58,925 + FET**

Wee Vac The Wee

Vac fits through a standard doorway and can pump up to 40 gallons of grease at a time. It has a female camlock so it can be downloaded into your truck. It features a 110 volt vacuum pump. **Price: \$1,240**

SPRING MOUNTS

decrease fatigue on your tank frame, mounts to most tanks, easy bolt or weld on style, heavy-duty stress relieved springs.

Mounts with springs...**\$82.00**

Springs alone**\$11.00 each**



2000 Freightliner FL70, Cummins

230 HP, 183,000 miles, 6 speed transmission, PS/AC, Air brakes, 35,000 GVW, **New 2200 gallon, carbon steel vacuum tank**, 3" inlet, 4" outlet, rear work lights, 20" top primary, 20" Rear manway, 5-gallon secondary, Aluminum toolbox. **NEW Battioni MEC 8000 vacuum pump**, 240 CFM, gearbox driven

Price:**\$35,000**

P.O. Box 39 Dayton, IN 47941 Toll-Free: **877-296-2555** Phone: **765-296-2027** Fax: **765-296-3027**

www.wee-engineer.com

NO COMPROMISE



Masport
HXL400WV

At Armstrong Equipment, we believe life and business require certain compromises, but not on those things on which your business and family depend. A beautiful, new and shiny vacuum truck with a burned out pump is nothing more than uncomfortable transportation at four miles per gallon.

Your customers depend on you! Your employees depend on you! Your family depends on you!

We think you should be able to depend on **us!** That is why we sell the most dependable vacuum pumps, parts, valves and tank components available. When it comes to quality and reliability in the tools that make your business successful, there should be:

“No Compromise.”

We proudly stock Masport, Jurop, NVE, Fruitland and G-D Wittig vacuum pumps, Sutorbilt blowers, Garnet Instruments SeeLevel gauges, Clearflow Heavy Duty valves and most other vacuum truck components and accessories. We can also provide replacement pumps and repair kits for most major brands. For more information call us toll free at **800-699-7557**.

ARMSTRONG EQUIPMENT INC.

800-699-7557

11200 Greenstone Ave. • Santa Fe Springs, CA 90670

562-944-0404 • Fax: 562-944-3636

www.vacpump.com

FRUITLAND
RCF500F



GD Wittig
RFL100



GD Sutorbilt
4M



NVE
506

Jurop
R260

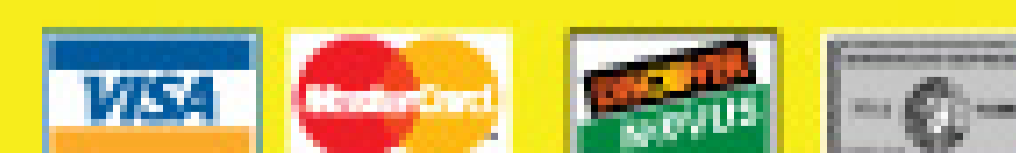

YOUR PROBLEM IS



Jim Pierce, Southeastern Division Manager

JUST ASK. IS THERE SOMETHING WE CAN DO FOR YOU?

We've always felt that our customer's problems were our problems, too. It was one of our founding principles. The people in the industry we serve, their integrity, and their zeal to provide good service mean a lot to us. That's why we've worked hand-in-hand with our customers for nearly 40 years; listening and helping them solve their problems.

So even though your restroom business may be going through some rough times right now, when things get better we believe that quality, integrity and service will have prevailed – in your business and in ours. Thanks for your loyalty and trust.



OUR PROBLEM, TOO

ONE TRUCK SHORT OF GOOD SERVICE

July 2005. Hurricane Dennis had just struck the Florida panhandle, and one of Jim's customers was moving his operation to the Pensacola area to set up for the Forest Service and FEMA. The customer's entire crew was on the panhandle, yet he was short one pump truck. The truck was in Atlanta.

Jim packed a bag, and took off with the truck toward the disaster area. He got as far as Montgomery, Alabama the first night. Due to the crush of evacuees, there were no hotels available so he slept in the truck cab. He arrived at the staging area the next day, and then spent a couple more nights in the truck, coordinating deliveries for his customer, and generally helping out any way he could.



VISIT WWW.POLYPORTABLES.COM TO SEE OUR COMPLETE LINE OF PRODUCTS AND SERVICES



POLY-STANDARD

The Poly-Standard has been the backbone of the PolyPortables line for almost 40 years. It's been tried and proven under every conceivable condition and it's still one of the best restroom values on the market. Many successful businesses have been built around the Poly-Standard unit.

VANTAGE

Looking for the best? The Vantage is a double-walled unit that is built like a fort, with smooth interior walls for easy cleaning. A wide doorway offers convenient entry and there are features that make the Vantage a real workhorse and a pleasure to handle. Check it out online at www.Polyportables.com

INTEGRA

The Integra features a high Keystone roof and wide entrance doorway. It has become our most popular restroom. Many structural parts are interchangeable between the Poly-Standard and Integra models thereby reducing parts inventories and enabling operators to keep their inventory active.

Visit www.Polyportables.com to see our complete line of:

- Portable toilets
- Special needs and VIP units
- Hand Wash stations
- Pumper and flatbed trucks
- Cleaners and deodorizers from Green Way Products
- Business and marketing tips

TOILET DEODORIZERS • TOILET CLEANERS • AIR FRESHENERS • INSECT REPELLANT

All Green Way deodorizers, cleaners and air fresheners are earth-friendly, people-friendly products. They are developed and manufactured in our facilities in Dahlonega, Georgia by Green Way Products, a PolyPortables sister company.



File or Pile?

Follow these six steps to better paperwork organization and you'll soon break free from menacing office clutter

By Christie Youd

Look at just about anyone's workspace and you're bound to see the same thing: piles and piles of paper ... on the desk, the filing cabinet and even on the floor. Paper has overrun many offices, causing stress, confusion and lapses in productivity.

How can paper cause so much turmoil? The answer lies in how we deal with it. When it comes to paper clutter many people make the "putting away" process too complicated. Rather than doing something with the paper, they set it aside. And there is no home for active paperwork representing work that needs to be done. Those papers get spread all over the desk and moved from one side to the other.

Fortunately, you can control the clutter and reclaim your desktop (and even your floor). Use the following six tips to de-clutter once and for all.

1 Create a home for active paperwork

Many people rely on an inbox for active paperwork, and that's one of the biggest mistakes when it comes to de-cluttering. An inbox inherently lends itself to inaction. Do you often have paper sitting in your inbox for a long time? Do papers slip between the cracks because they got buried in your inbox? Is your inbox regularly overflowing? Most people answer "yes" to at least one of those questions.

A better solution is to have a work processing system in your desk file drawer. This tickler file system consists of 31 hanging files, one for each day of the month. Behind those are 12 additional hanging files, one for each month. As each piece of active paper comes into your office, you make a decision as to what date you are committed to taking action on that paper and file it in the appropriate date's file. If it's something you need to schedule further in the year, put it in the appropriate month's file. Each evening you simply pull out the dated file for the following date and prioritize all the tasks the papers represent.

2 Prepare your file drawers

Before you start filing the rest of your papers, you need an efficient filing system in place. To begin, make sure you have access to four file drawers. You should be able to reach each of them while sitting behind your desk. One file drawer will be the tickler file system you just created. The remaining three are what's necessary to properly fit all the documents the average person needs to keep for work.

Keep the system simple. Create five broad categories that encompass all the kinds of papers you need to keep for your job. Research shows the human mind can keep straight up to five distinctions without having to stop and think. Any more than five distinctions is too much effort, and that's when people set the paper aside rather than file it. An example of five broad categories may be Administrative, Sales & Marketing, Financials, Production and Research & Development.

Christi Youd operates the consulting business, Organize Enterprise LLC. She is the author of *Organize Your Office for Success*, and *Organize Your Home in 10 Minutes a Day*. To learn more, visit www.OrganizeEnterprise.com.

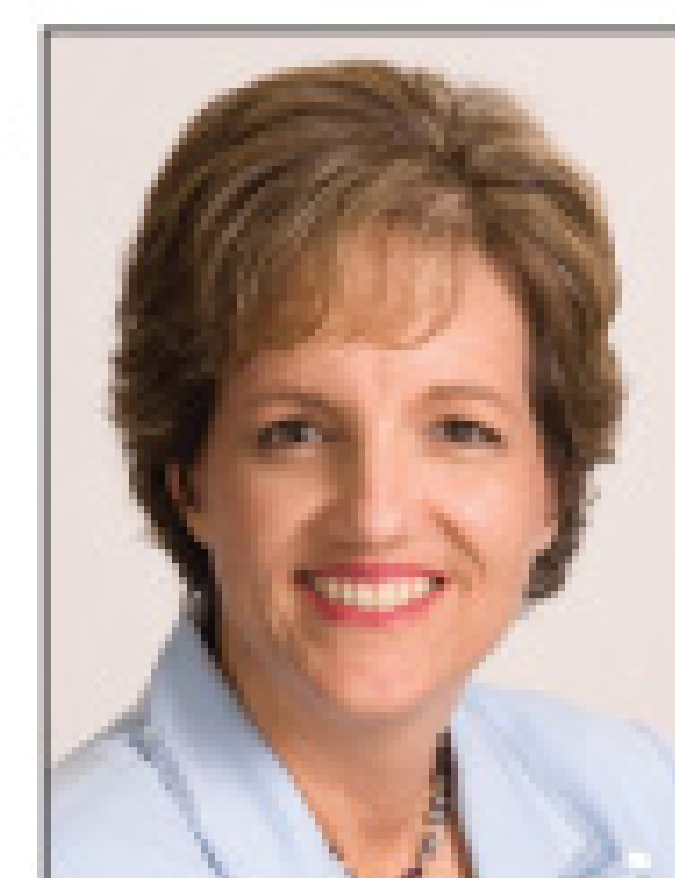

When you know how to file effectively and keep a clutter-free desk, you'll experience less stress and greater concentration, which ultimately leads to increased productivity ... A little de-cluttering today will yield greater productivity and profits for years to come.

Choose the categories that make the most sense with your roles and responsibilities.

Do not subdivide your categories, that complicates the system. You want to be able to find any document by merely remembering "One of Five-Alphabetized," meaning the paper you need is in one of five categories and in alphabetical order. Keeping your filing system this simple also allows others in your office to find documents they need when you are away.

3 Create individual files

Now that you have file drawer space ready and five categories, it's time to create the individual files. You may prefer to delay the actual file-naming process until you've gone through the sorting process. If so, for now simply get your drawers ready to receive all those papers.

Within each of your five broad categories you will have individual file folders. For example, if Sales & Marketing is one of your broad categories, your files within that category may consist of "advertising," "publicity," etc.

When choosing the headings for files, always choose a noun and choose a broad heading. It's better to have fewer files with broader headings, each with 50 pages, rather than many specific files, each with five pages. However, if a file becomes too large and cumbersome, you can subdivide it. Just remember that the greater number of files, the more difficult it becomes to locate and retrieve papers when you need them.

If there are numerous possibilities where a paper could have been filed, you'll learn not to trust your filing system. As a result, you'll start to pile instead of file.

Give each individual file folder its own hanging file, and give both the exact same label. Then, when you need a file, pull out the folder only. Leave the hanging file in the drawer to save its place. When you are finished with the file, read the label on the file folder and find the same label in the drawer on a hanging file. Again, keep everything alphabetized.

4 Insist on proper file placement

When labeling files, many people make the mistake of labeling one file on the left side, one in the center, and one on the right side throughout the drawer. This looks nice when you set it up, but as soon

as you add a new file, you mess up the system. Soon you're not sure where to expect the next label, so you have to slow down and study your file labels every time you need to file a paper away. As a result, you'll have the tendency to set the paper aside rather than file it.

A better approach is to use straight row filing, where each tab is directly behind the tab in front of it. Keep the tabs in alphabetical order. That way you know where each tab is and in what order they come.

5 Speed sort through the de-cluttering process

With your tickler file prepared, filing system created and individual file folders ready, it's time to tackle the mounds of paper in your office. Check with your accountant, attorney or manager about what types of documents you legally have to save. Then, as you handle each piece of paper, ask yourself the following questions:

- Can I discard this? (Under what circumstances will you use this piece of paper again? If you need it again, is there another source to get it from?)
- Can I delegate this?
- Can I handle this in 60 seconds or less? (If it's something you can do right now in 60 seconds or less and get it out of your life, then do so.)
- What date am I committed to take action on this? (Put it in that day's tickler file.)
- What heading do I want this filed under in my files?

This is a filter system where you get rid of as much as you can. By the time you're done with these questions you should only be left with the documents you truly need to keep.

6 Insist on maintaining a proper fit inside your file drawers

You have a proper fit if you can open a drawer, open the file, insert the paper and close the drawer using one hand. When there is an improper fit, the filing process becomes a bother and you tend to procrastinate filing papers. Therefore, when your filing cabinets get too stuffed, go through the speed sorting questions again. Eliminate what you can. Move the rest to long-term storage.

LESS PAPER = LESS STRESS

When you know how to file effectively and keep a clutter-free desk, you'll experience less stress and greater concentration, which ultimately leads to increased productivity. So no matter how bad the paper clutter is in your office, get started on these tips today. A little de-cluttering today will yield greater productivity and profits for years to come. ■

Refrigerator Magnets Work!!



As Low As 35¢

Quantity Discounts
2-color Imprint

Pumper Truck Shape
Actual Size 4 1/2" x 2"

Straight Line Setup **FREE!**

Call For Details
1-800-758-2743



BLACK TIE

MANUFACTURING

SIMPLY THE BEST TRAILER BUILT...



...Supported by the **BEST Re-Rental Program Available**
(\$1,500,000 paid to partners in 2008)

CALL NOW FOR A QUOTE AND RENTAL MARKET ANALYSIS

877-253-3533
www.blacktiemanufacturing.com

©2008, Black Tie Manufacturing, Inc.

MOBILE RESTROOM SUITES



CUSTOMIZE YOUR OWN!

BlueMuscle™

Potty Fresh Plus™

Portable Toilet Deodorizer



GREAT PRICING • GREAT PERFORMANCE

SURCO®

- Since 1946 -

US - 1-800-556-0111 • Intl. - 412-252-7000
Canada - 905-216-8018
Website - www.surcopt.com

©2009 SP

LELY

Commercial Wastehandling Equipment

Put Our Experience to Work for You

Aluminum Tanks • Full Open Door Hoist Tanks

ASME DOT 407/412 Code Tanks

- Standard and custom tanks
- Carbon steel and aluminum available
- A tradition of reliable service
- Large range of sizes (400 - 6000 Gal.)
- Complete line of parts



- 1) Vacuum and Pressure Relief Valves
- 2) Easy to Read Vacuum and Pressure Gauges
- 3) Balanced Tubular Pump Drive Shafts
- 4) Full Length Hose Trays
- 5) Get Tank Protection with Aluminum or Spray Liner
- 6) Low Profile Primary Shut-Off with SS Float Ball
- 7) 20" Top Manway
- 8) Three 5" Sight Glasses
- 9) Stainless Steel Boxed Upper ID Light Bracket with Truck-Lite Brand Lights
- 10) 24" Rear Manway with 4" or 6" Discharge with Camlock Fittings (up to 36")
- 11) DOT Approved Step Bumpers
- 12) 4 Anti-Sail Mud Flaps
- 13) Large Hose Hooks
- 14) 3" or 4" Intake
- 15) We carry blower packages for your heavy duty jobs

Portable Toilet Trucks

Available On All Models

- Hot Shift PTO with Automatic Transmission
- Balanced PTO Axle
- Heavy Duty Toilet Carrier
- Trailer Hitch
- Spring Rewind Reel (Optional Dual Service)
- 2" Bucket Quick Fill
- Driver Side Work Station
- Dual Side Tool Box



- Electric Water Pump 40 PSI 6 GPM (Air Pressurized Optional)
- Coated Water Compartment
- Full Set of Working Lights
- Truck-Lite Lights
- 50 ft. Water Hose with Nozzle
- Vacuum and Pressure Relief Valve

Lely Manufacturing, Inc.

P.O. Box 789 Wilson, NC 27393

800.334.2763

sales@lelyus.com



—partners in wastehandling—

www.lelyus.com

Seal it Tight! Seal it Easy! Seal it Fast!

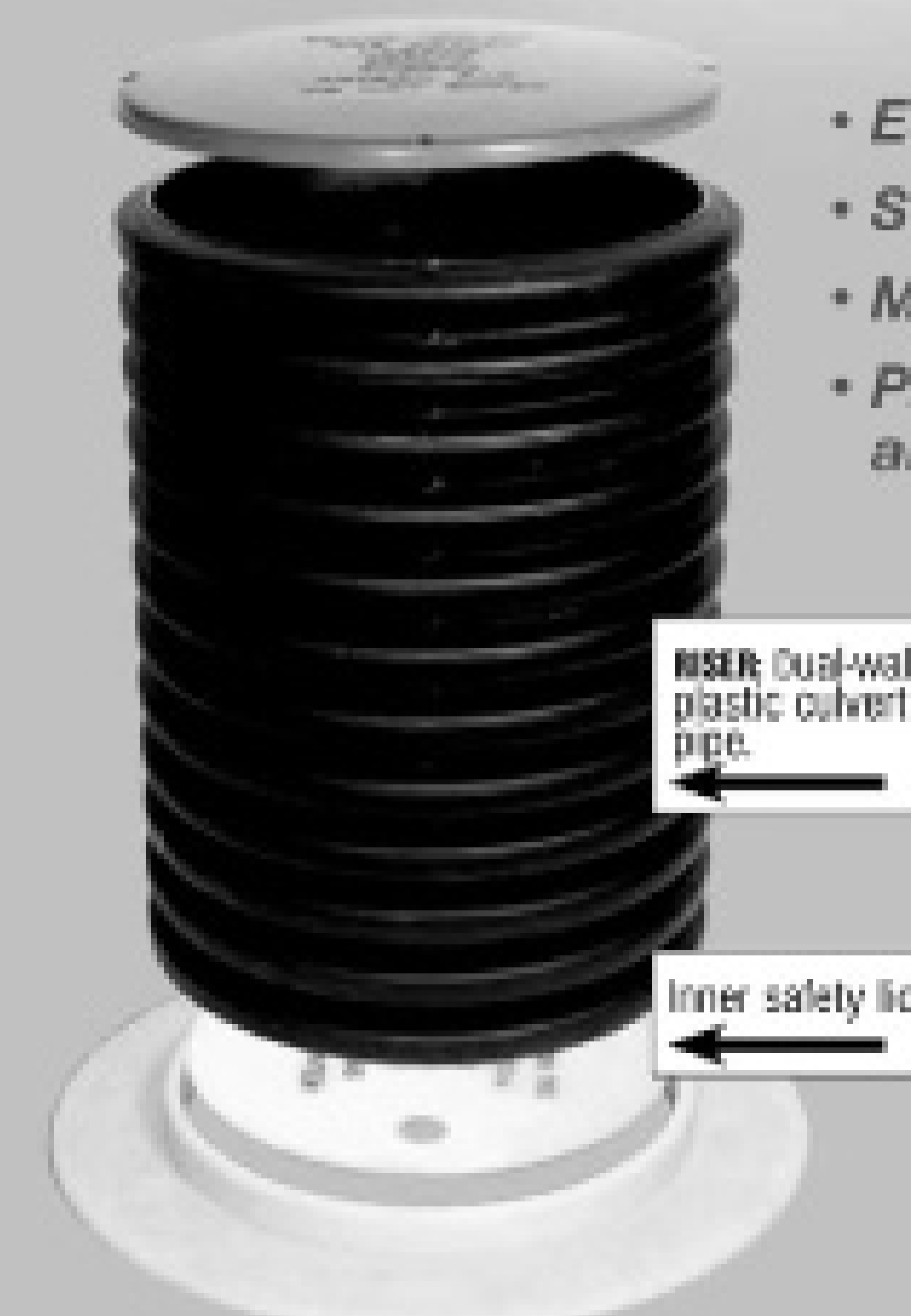

- Easy 10 minute installation!
- Secure fit for all systems!
- Made & sold by septic installers!
- Prevent ground water infiltration and save money at the same time!



Apply foam inside to tank.



Place ring over opening and apply foam.



Place plastic manhole pipe on top.



Final lid.

Are you tired of using risers that are too tall or too short for the job you are completing? Plastic riser pipe will give an exact height each time. Try our system and you will never have to carry concrete pipe and lids again. Save time by not having to assemble multiple sections.

- Seal-R® Lids Available in 12", 15", 18", 24", 30", 36".
- Seal-R® Rings Available in 18", 24", 30".
- Inner Safety Lids Available in 18", 24".

Seal-R® Lids can be purchased. Seal-R® Lids are constructed with UV resin to resist degradation from exposure to sunlight.

For more information, call us today!

BrenLin Company, Inc
Manufacturers of Seal-R® Products
Herman, MN

888-606-1998

Fax: 320-877-3001 • Email: brenlin@brenlinet.net

www.seal-r.com

We Have Money To Loan



If you need equipment to grow and your bank said "NO," call "JIM THOMAS"

We are not affected by the economy. Conserve your working capital. Keep existing credit lines intact, and enjoy the security of knowing financing is there when you need it. We offer loan and leasing plans tailored to individual needs.

- Portable Toilets
- Sewer Equipment
- Pumper Trucks
- TV Inspection
- Water Jetters
- New and Used Equipment
- Vacuum Trucks

- ❖ Programs offer longer terms for older equipment.
- ❖ We do start ups.
- ❖ 90 Day Delayed Billing.
- ❖ Seasonal Payment Programs Available

Get Pre-Approved for the Pumper & Cleaner Environmental Expo

Prompt, no nonsense financing designed to meet individual requirements. Payment plans that are generally lower than other finance plans. With years of experience, we understand the competitive nature of your business.

We're prepared to act quickly and decisively!

Toll-Free 877-333-4539 • www.keycommercial.com



KEY COMMERCIAL CORP.

Commercial Equipment Leasing

"Getting You The Credit You Deserve"

LOOK FOR OVER STOCK SALE- PRICES GOOD ONLY WHILE SUPPLIES LAST!



VERTICAL MUFFLER

OVER STOCK SALE!
3 LEFT AT THIS PRICE!!

1 1/2" ~~\$197.95~~ **\$160**
2" ~~\$196.95~~ **\$160**
3" ~~\$278.95~~ **\$220**

*3" Openings Sold Unpainted



10 GALLON SECONDARY

OVER STOCK SALE!
7 LEFT AT THIS PRICE!!

~~\$482~~ **\$299**

*3" Openings Sold Unpainted



21" MANWAY
OVER STOCK SALE!
10 LEFT AT THIS PRICE!!

\$165

*Sold Unpainted

OVER STOCK SALE

5 LEFT AT THIS PRICE!

JUROP R260



- 363 CFM
- 18" CONTINUOUS DUTY
- BALLAST PORT COOLING
- AUTOMATIC OILER

\$2595

BUY BULK AND SAVE!

EPDM SUCTION BULK 100 FT ROLLS



GET IT IN COLORS
SAME LOW PRICE

2" ~~\$2.19~~ **\$1.69** 3" ~~\$3.69~~ **\$2.89**
4" ~~\$6.59~~ **\$5.39** 6" ~~\$11.35~~ **\$10.95**

SAVE MONEY- PROTECT YOUR FITTINGS!

SAFETY LOCK

2" **\$1.65**
3" **\$1.95**
4" **\$2.50**



SAFETY BUMPS

COMFORTABLE HANDLE
SAFEGUARDS YOUR FITTINGS

2" **\$16.25** MXF SET
3" **\$25.95** MXF SET
4" **\$33.75** MXF SET

COUPLINGS AND REDUCERS



100'S
OF
THEM!



FEMALE X MALE REDUCER



3" X 2" **\$17.85**
4" X 3" **\$26.25**
6" X 4" **\$45.95**

EPDM SUCTION CPLD M X F QUICK CONNECT



GET IT IN COLORS
SAME LOW PRICE
INCLUDES FITTINGS!

NEW LOW PRICE!

3" X 20' ~~\$84.95~~ **\$79.95**
3" X 25' ~~\$101.95~~ **\$94.95**
3" X 30' ~~\$117.95~~ **\$109.95**
3" X 33' ~~\$129.95~~ **\$118.95**

PORTA -TUFF HOSE

NEW PORTABLE TOILET HOSE!
A Varco Exclusive!



2" X 25' ~~\$91.70~~ **\$91.70**
2" X 30' ~~\$108.70~~ **\$108.70**
2" X 35' ~~\$125.45~~ **\$125.45**
2" X 40' ~~\$142.20~~ **\$142.20**

- NO CUFFS!
- 100 FT LGTHS
- EASY REPAIR!
- MOST FLEXIBLE HOSE WE HAVE!

TIGER TAIL CPLD M X F QUICK CONNECT



INCLUDES FITTINGS!

2" X 25' ~~\$96.75~~ **\$91.70**
2" X 30' ~~\$113.00~~ **\$108.70**
2" X 35' ~~\$129.75~~ **\$125.45**
2" X 40' ~~\$145.50~~ **\$142.20**

VALVES PUMPS

LEVER VALVES



3" **\$105.95**
4" **\$154.95**
6" **\$268.95**

CRAZY PRICE!

JUROP PN58



- 230 CFM
- FORCED OIL LUBRICATION
- 3" CON-NECT

\$1580⁹⁵

JUROP PN23



- 93 CFM
- FORCED OIL LUBRICATION
- 3" CON-NECT

\$1140⁹⁵

NO ONE BEATS OUR PUMP PRICES!

VAC TRUCK ACCESSORIES



1 1/2" BRASS VACUUM RELIEF VALVE

2" **\$173.25**
3" **\$173.25**

\$21.95



BRASS PRESSURE VALVE

1 1/4" **\$24.95**
1 1/2" **\$28.95**
2" **\$36.95**



VACUUM PRESSURE GAUGE

- 0-30 Vacuum
- 0-30 PSI
- Liquid Filled
- 1/4" Male NPT

2.5" Face **\$13.95**
4" Face **\$40.95**



2" **\$157.95**
3" **\$215.95**

HOSE BREAKING OFF AT TRUCK? YOUR CHOICE SAME PRICE

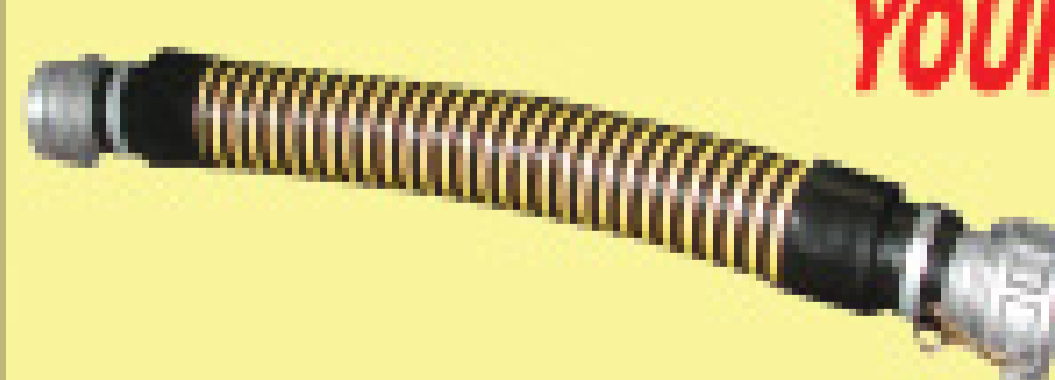

VARCO FLEXI-JOINT

3"

\$51⁹⁹

4"

\$65⁹⁹



VARCO TUFF-JOINT

SLUDGE HOE



\$62.50

SCRAPERS



from **\$50.00**



SPOONS
Includes Fiberglass Handle!

from **\$105**

FREE CATALOG



SHOP ONLINE AT WWW.VARCOPUMPER.COM

OPEN LATE NITES AND WEEKENDS!

TOLL FREE

866-872-1224

SOURCE KEY
8P9





The New Way For Grease Disposal

Does your customer have one?



Order with or without the containment and save cost

The Outdoor Envirotub is environmentally friendly and made from 100% recycled materials. Light weight for easy movement. Stores up to 1200 pounds of grease. Non-stick plastic surface for easy cleaning and eliminates grease build up. Self closing lid to reduce odors and rain water. Built in containment, catches overflow, spills, perfect for coastal communities. Keeps trash areas clean, endorsed by property management and restaurant companies.

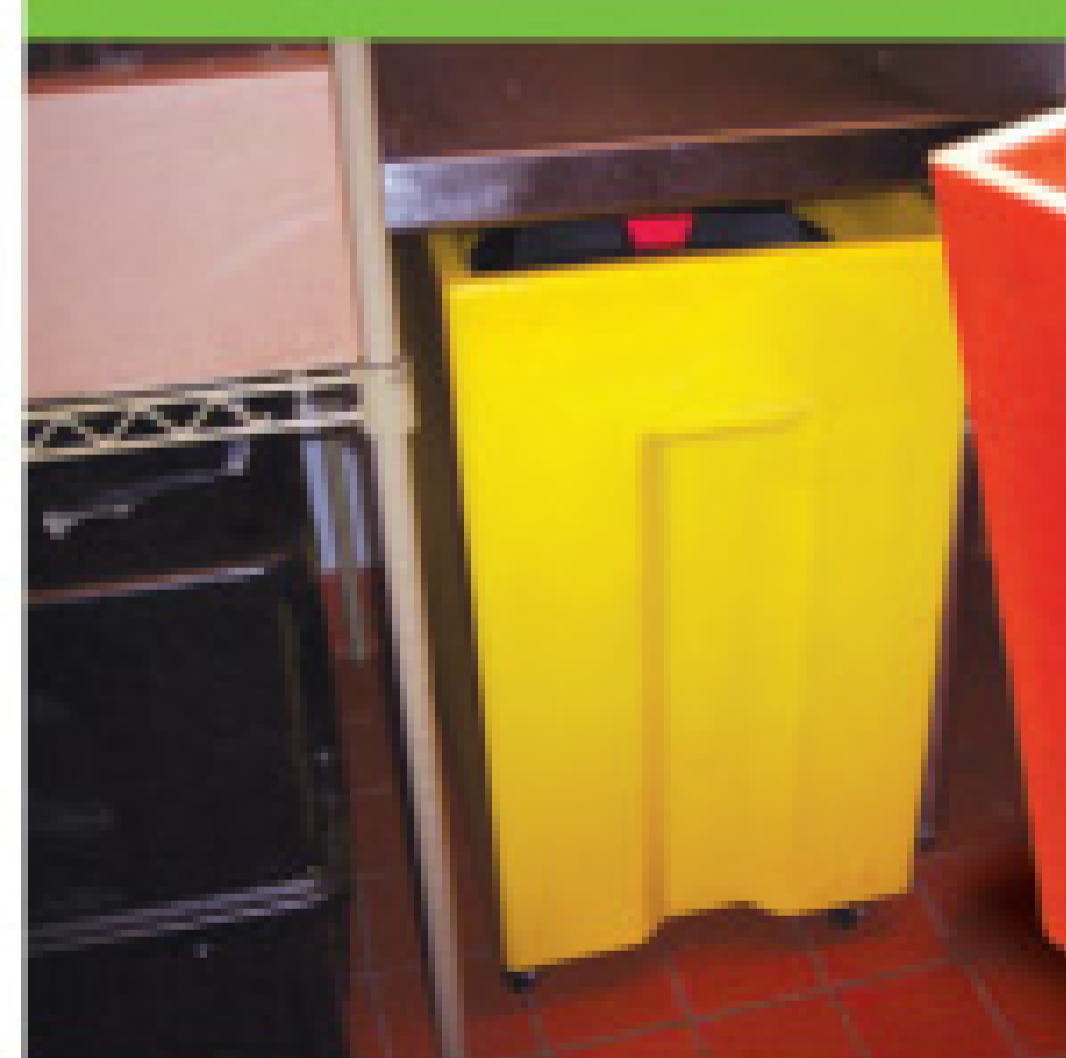

The indoor tub made to keep grease thieves away. Stores up to 55 gallons of grease. Fits under most two and three compartment sinks. Perfect for small kitchens with limited space, malls, colleges and food courts.

- > Self Closing Lid
- > Full Containment
- > 100% Recycled Plastic
- > Easily movable

ENVIROTUB

www.envirotub.com

PO BOX 1343, CORONA, CA 92878

1.866.777.4322

Kanaflex® 220RS Rubber All-Weather Suction Hose

SUPER FLEXIBLE IN COLD WEATHER

Call for Low Prices on 100' Lengths & Coupled Hose Assemblies

A revolutionary new method of manufacturing rubber suction and discharge hose has drastically reduced costs to hose users. The new process, ten years in development, utilizes Kanaflex SBR TYPE "T" POLYMER to give the lightweight, rubber hose outstanding flexibility and long life.

New Series 220 rubber suction and discharge hose has excellent dimensional stability and is easy to couple. Manufactured in six sizes from 1-1/2" through 6", the hose is available in 100' lengths. I.D. and O.D. are smooth. Temperature range is -40° F to 160° F – ideal for industry and construction job site use.



SAVINGS UP TO
50%
FOR SUCTION &
DISCHARGE HOSE
USERS!

Distributors of: **Dunlop • Goodyear • Kanaflex • Plastiflex Hi-Vac & Other Hose • P-T & Evertite Quickcouplers Dixon & Le-Hi Couplings • Hose Clamps • Banding Equip.**

MRP

Toll-Free
1.800.325.3730

Milwaukee Rubber Products, Inc.

www.milwaukeeerubber.com

FAX: 262.781.1742

MAILING ADDRESS: P.O. Box 451 . Butler, WI 53007

WAREHOUSE: N52 W13319 Falls Creek Ct. . Menomonee Falls, WI 53051



For a Great Reward ...



We are an ASME shop.
Best Built Vacuum Trucks in America
vacuum trucks ♦ parts ♦ service

www.glendalewelding.com



623.937.7414



Since 1937
Glendale Welding Co.
Glendale, Arizona



50 YEARS OF DEPENDABILITY

TUFF-JON



- One-Piece Construction
- Lightweight
- Rust-Free Hardware
- Wood and Poly Skids
- Large Variety of Colors

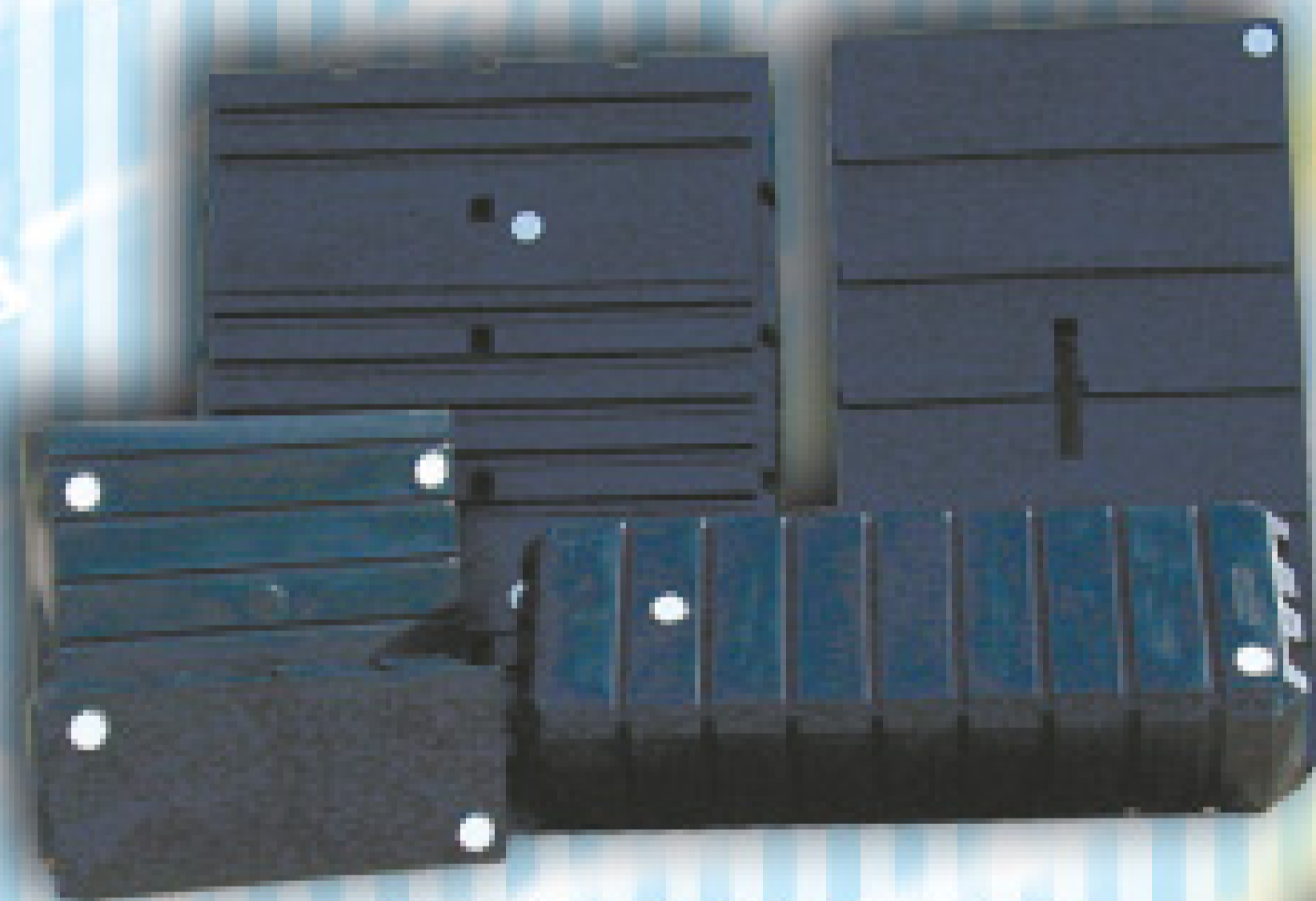

Tanks in 60, 105, 225, 300 and 440 Gallon Sizes



Tuff-Jon III



Tuff-Jon



TJ Junior Single Free Standing Sink (20 gallons fresh water)



90 Gallon Free-Standing Sink (45 gallons fresh water)

— OPTIONAL ACCESSORIES —



7-1/2 Gallon Handwasher optional for the standard Tuff-Jon



Tuff-Jon with Lifting Bracket Assembly



60 Gallon Rinse Tank



Sky Heater



Sinks available for the Tuff-Jon III

The TSF Company Inc. | 2930 S St. Phillips Rd. | Evansville, IN 47712

Toll Free: **1-800-843-9286** | **812-985-2630** | Fax: **812-985-3671**

E-mail: **tsftuffjon@sbcglobal.net** | Web Site: **www.tuff-jon.com**



PORTABLE TOILETS / HOLDING TANKS / HAND WASH UNITS / ACCESSORIES

Regulator Clarifies Ohio Onsite Rule Proposal

By **Scottie Dayton**

Todd Paulus, unit manager for the Stark County Health Department in Canton, Ohio, states that a bill in the state legislature revising Ohio's onsite regulations will not cost homeowners as much as \$50,000 to install onsite systems, as some have claimed.

"A few who oppose the state's Home Sewage Treatment System Study Commission findings are attempting to invoke public outcry against the rules by overinflating the costs of these systems," he says.

"Stark County is using most of the principles in the proposed regulations, and our installation costs are \$7,000 to \$15,000.

Occasionally, in the worst soils, a drip system will cost \$18,000 to \$20,000. Since January 2008, we've installed 333 systems. The average costs are \$9,850 for new systems, \$8,475 for replacements, \$3,501 for alterations, and \$8,438 overall."

In July 2007, Ohio rescinded new onsite rules that required some properties to replace conventional drainfields with mounds or pretreatment with low-pressure pipe drainfields. Counties were left on their own to determine what to do next.

Stark County opted to install less costly, less maintenance-intensive systems that still abided by most of the principles of

the 2007 law. Besides conventional drainfields when soils permit, the county uses dosing siphons or Flout system (www.flout.net), and some flood dosing. Furthermore, the cost of technology has decreased since 2007, and more options are available.

According to Paulus, the most debated principle in the proposed rule requires a vertical separation distance for high seasonally perched water tables and harsh limited soil conditions. Approved procedures to reduce the distance would be to elevate or pretreat, or both. Opponents have objected to the additional expense of doing so.

Rules and Regs is a monthly feature in Pumper. We welcome information about state or local regulations of potential broad interest to onsite contractors. Send ideas to editor@pumper.com.

Most soils in Stark County are moderate. Paulus admits that counties with worse soils may have a different perspective than his. "The average prices I mentioned included systems ranging from standard trenches and mounds to pretreatment with flood or (low-pressure pipe) dosing," Paulus says. "Fewer than 2 percent are drip systems." ■

NU CONCEPTS

MANUFACTURER OF QUALITY PORTABLE RESTROOMS AND SINKS



Dual VIP Restroom Trailer

From \$9,841

Ideal for:

- Weddings / Parties
- Sporting Events
- Food Festivals
- Community Events
- Restroom Remodeling
- Movie Production

Features:

- Solar Powered
- Self-contained
- Flushing, china toilet
- Enclosed sink
- Power Converter (option)
- Air-conditioning (option)
- Interior Heater (option)
- Sink Water Heater (option)



1737 S. VINEYARD AVENUE • ONTARIO, CA 91761

PHONE 909-930-6244 • TOLL FREE 800-334-1065 • FAX 909-930-6237

www.NUCONCEPTS.com

FACTORY AUTHORIZED SERVICE

for: **ROOTS-DRESSER, ROBUSCHI, HIBON, H&H, HOLMES and KAISER Blowers**

Fast Delivery - Large Selection - Best Price - Great Service
New - Rebuilt - Core Exchange

Exchange Units - Most Models of Roots, Robuschi, Hibon, Holmes, H&H and Kaiser

- ◆ Roots 1125 Trinado
- ◆ Roots 1021 DVJ
- ◆ Roots 1024 RAS
- ◆ Roots 1021 RAS
- ◆ Roots 824 RCS
- ◆ Hibon SIAV 840
- ◆ Hibon SIAV 8702
- ◆ Hick Hargreaves 4084

New Blowers & Pumps Available From POWER VAC

- ◆ Roots
- ◆ Robuschi
- ◆ Hibon
- ◆ Hick
- ◆ Masport
- ◆ Moro
- ◆ Aerzen

DRESSER ROOTS

hibon KAISER

ROBUSCHI

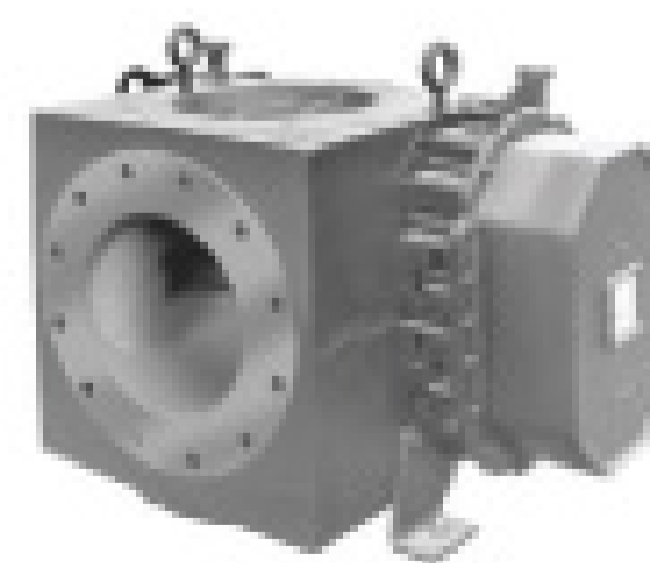

POWER VAC
INCORPORATED

1-800-822-4887

W228 N2792 Duplainville Rd. • Unit G. • Waukesha, WI 53186
(262) 542-8989 • Fax: (262) 542-6262 • www.powervacinc.com

Aluminum, Steel & Stainless
Tanks Manufactured,
Assembled and Serviced by
Quality Imperial Employees!



Imperial
Industries Inc.
Wausau, WI
800-558-2945



2009 I.H./ 4000 Gallon
Aluminum Stock Unit



After
28 Years

We Are Still
The "One" For ...

In-Stock Truck/
Tank Units
And Stock Tank
Bodies Ready
to Mount!

Customized Units
With Approval
Drawings,

Quality
Manufacturing
And Service,

Pumps, Toilets,
Wash Sinks and
Chemical Fresheners
for your
everyday needs.

MID-STATE
www.midstatetruck.com

Allen Luebbe
800-236-2044

allenl@midstatetruck.com

Slide-In Units, Portable Service Units and Toilets
In-Stock and Ready for Delivery

800.558.2945

"The Proud Tradition Continues ..."

Visit Our Web Site www.imperialind.com



Jim Stieber

jim@imperialind.com

Randy Tischendorf

randy@imperialind.com



Parts • Supplies • Equipment

HOSE
• Suction
• Transfer
• High Pressure



VALVES
• Lever
• Ball
• Piston
• Solenoid

FREE
318 PAGE
CATALOG!



dultmeier.com

1-800-553-6975

Davenport, IA

- Vacuum Trucks
- Sewer / Jetter
- High Pressure
- De-Watering



Vacuum Pumps



Transfer Pumps

1-800-228-9666

Omaha, NE

Experience Matters.

Custom vacuum tanks built to your specifications.

For nearly 50 years, our tank builders have been setting the industry standard for innovation and value. Everything we build is customized to your exact specifications. Start with a bare tank and add only the options that are suitable for your application. What about service? Our technicians can rebuild pumps or furnish parts such as vanes, seal kits, housings, and rotors for most pumps. Whatever you need, let us put our experience to work for you.



Bare tank w/no attachments

Bare Tank:

Prices are for the tank only with no openings, hatches, rails or other attachments. LMT can furnish items for you to attach to your tank at additional cost. Please call for more information and pricing.



Basic tank w/optional manway and hose trays

Basic Tank:

Prices include primary shutoff, full length rails (straight or tapered), 4" discharge nipple, and 3" intake nipple.

Check out some of the options:

- ✓ Manways (20", 25", 36")
- ✓ Full open door (2 types)
- ✓ Primary & secondary shutoffs
- ✓ Valves for loading & unloading
- ✓ Oil catch mufflers
- ✓ Suction hose & couplings
- ✓ Mounting rails & kits
- ✓ Vacuum pumps (Jurop, Masport, Moro, Fruitland, and others)
- ✓ Hose trays and hangers

And more...

LMT Basic & Bare Tank Prices:

(subject to change without notice)	Basic Tank	Bare Tank
1500 gallon: 54" dia. x 12' long w/1 baffle.....	\$ 5,150.....	\$ 3,765
2000 gallon: 60" dia. x 14' long w/2 baffles.....	6,200.....	4,850
2500 gallon: 66" dia. x 14' long w/2 baffles.....	7,100.....	5,700
3000 gallon: 68" dia. x 14' long w/2 baffles.....	8,000.....	6,570
3500 gallon: 72" dia. x 17' long w/2 baffles.....	9,550.....	8,030
4000 gallon: 78" dia. x 16' long w/2 baffles.....	10,685.....	9,125
4200 gallon: 78" dia. x 17' long w/2 baffles.....	11,170.....	9,590

Custom sizes up to 6000 gallon are available.

All lengths are can length excluding flanged and dished ends. All tanks over 70" dia. have 2 braces of 2" x 3" solid steel to prevent collapse of tank. All tanks are cleaned with an acid solution and prime painted. We can also customize the paint color for an extra fee. Tanks are manufactured with mild steel and are welded with submerged arc process for the best strength and appearance. Stainless steel is available at extra cost.



Call us at 800-545-0174 before you buy!

LMT Inc. - Custom Vacuum Tanks

Tel: 309.932.3311 • Fax: 309.932.3155 • info@tanksandpumps.com

www.tanksandpumps.com

Septic Tank Riser, Lid & Safety Pan™

FREE FREIGHT ON FULL CARTONS!

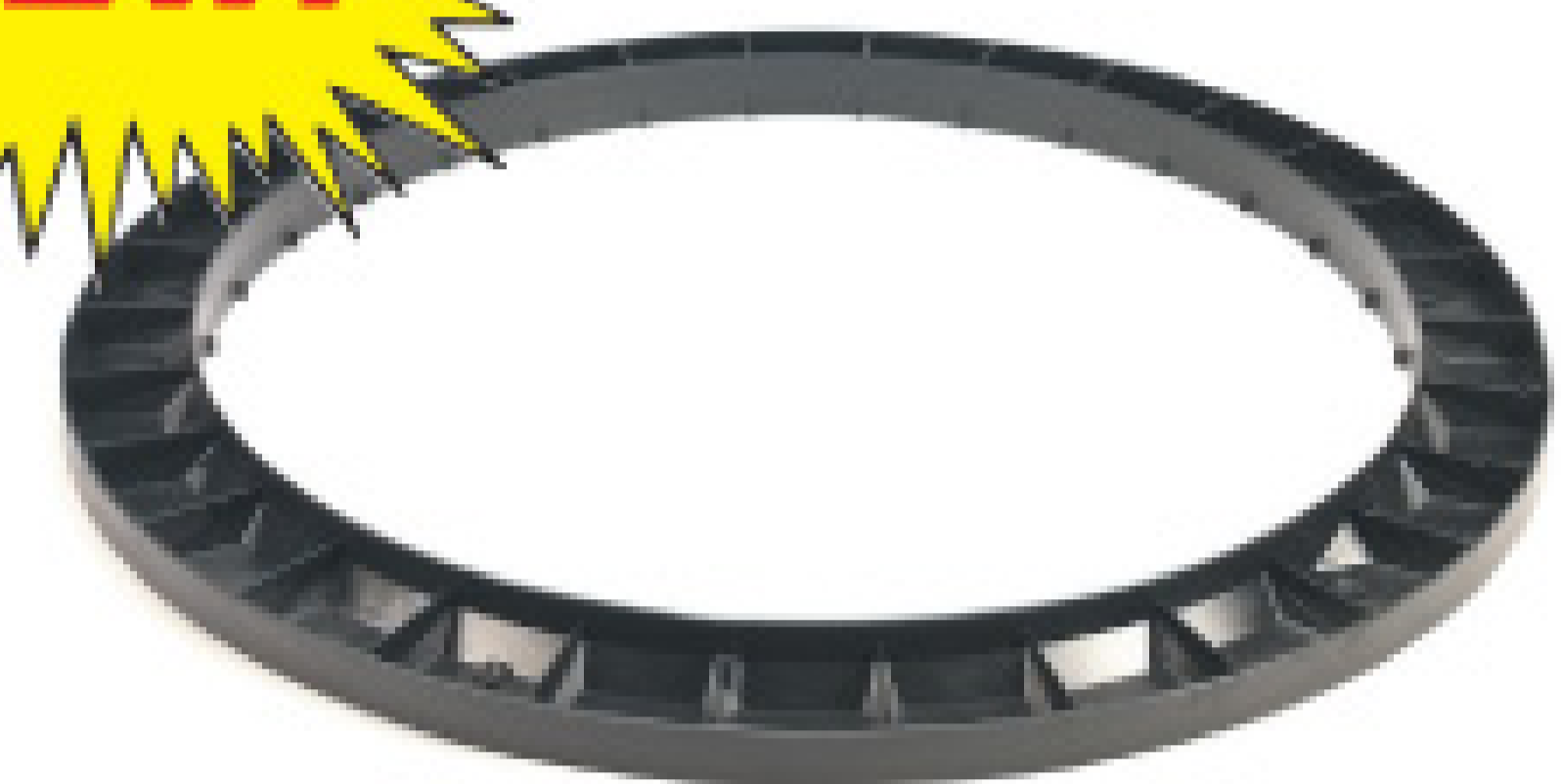

Tank Adapter Ring

New - Horizontal Safety Screw.

Safety Pan™ to Riser attachment with 6 vertical stainless steel screws.

Riser to Riser attachment with 6 vertical stainless steel screws.

Patent Numbers
5,617,679 &
5,852,901; other
pats. pending.

Riser Lid

with Molded-in gasket.
Available in 12", 16", 20" and 24" diameters.

Concrete Lid w/handle

Safety Pan™

Safety Pan™ available in 16", 20" and 24" diameters.

Riser

For septic tanks. Stackable in 6" increments. Available in 12", 16", 20" and 24" diameters.

Tank Adapter Ring

For mounting riser flush to top of tank when casting-in is not an option.

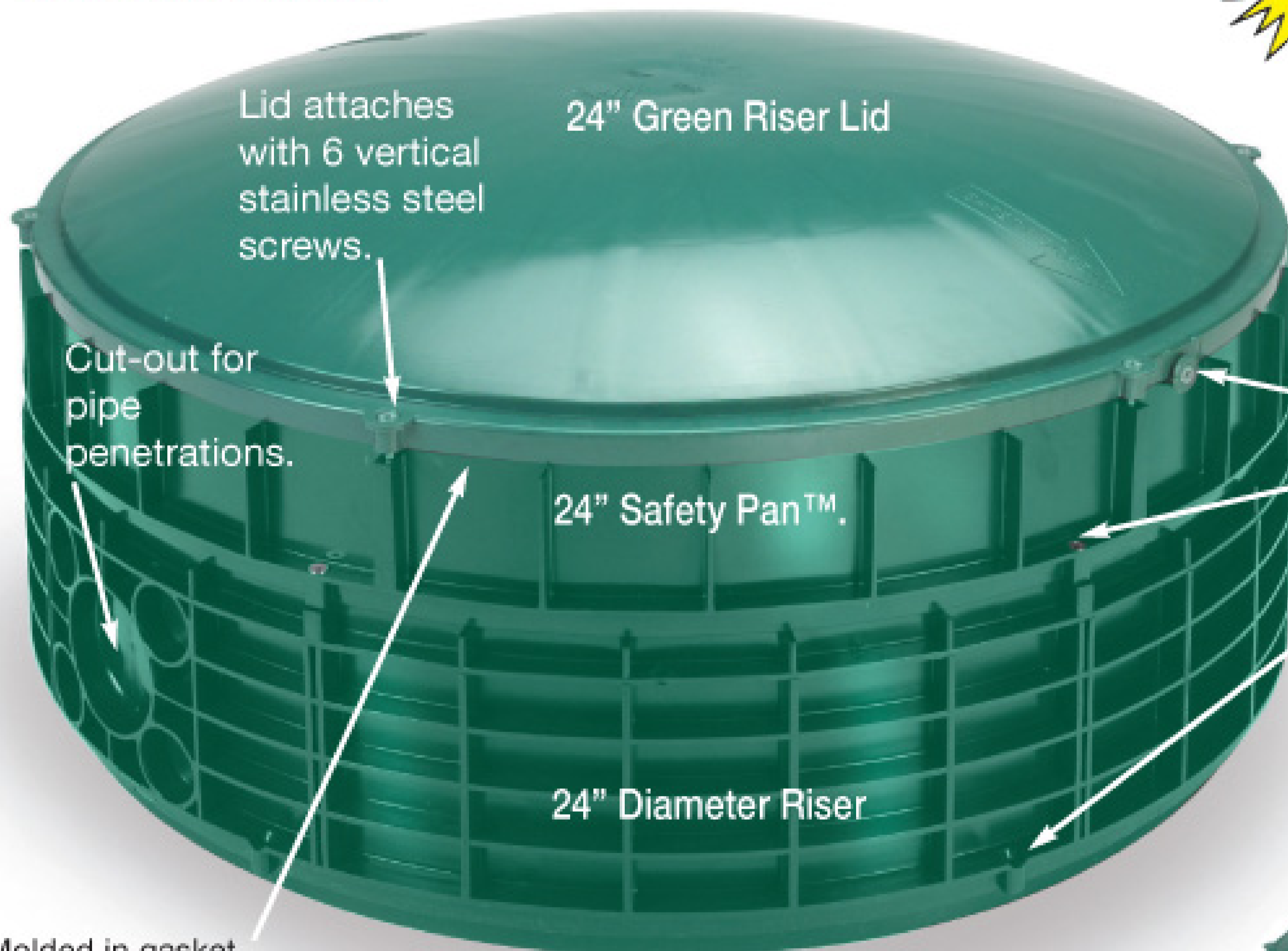

Lid attaches with 6 vertical stainless steel screws.

24" Green Riser Lid

Cut-out for pipe penetrations.

24" Safety Pan™.

24" Diameter Riser

Molded in gasket.

Available in 12", 16", 20" and 24" diameters.

Effluent Filters

Patent Numbers
6,319,403; D 431,629; other
pats. pending.

800 GPD
ANSI/NSF
Standard 46

4" Sch. 40 & SDR-35

EF-4
4" Filter

1500 GPD
ANSI/NSF
Standard 46

4" Sch. 40 & SDR-35

EF-6
6" Filter

Gas/Solids
Deflector

One-Piece Tank Seal

For concrete Septic tanks and D-boxes. Accepts pipes from 1-1/2" to 4". Mounts with or without concrete flash.



TS-4-RUBBER TANK SEAL
(will hold 10psi)
TS-4PRO TANK SEAL
(will hold 5" vacuum)

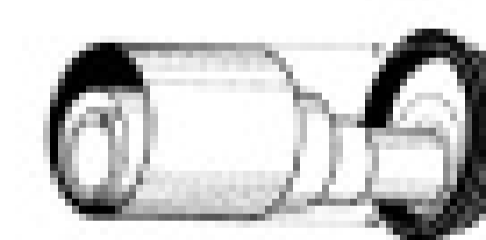

Free Freight: 32¢

Patent No's
4,951,914,
5,624,123
& 5,711,536;

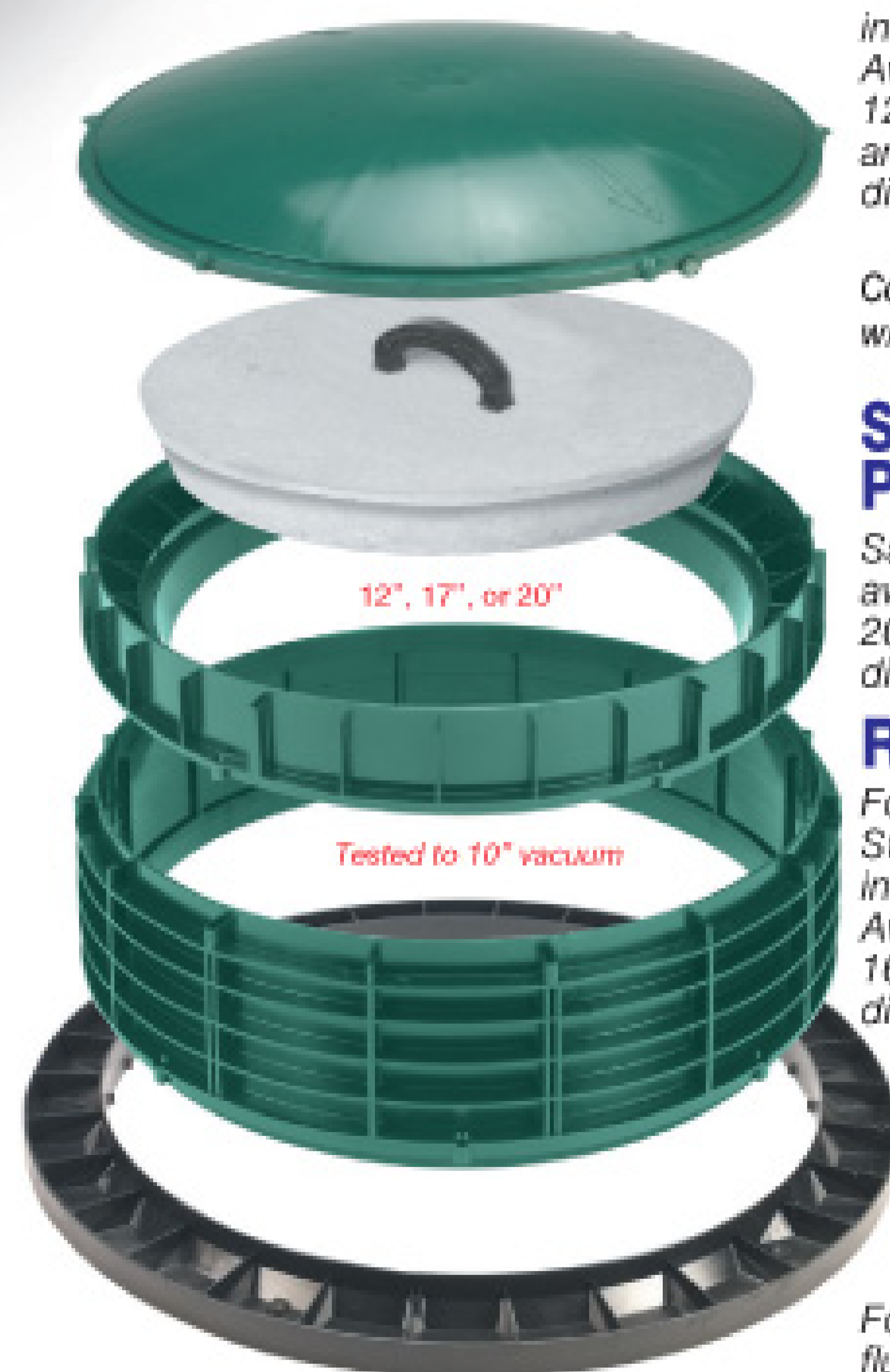

12", 17", or 20"

Tested to 10" vacuum

“We invest in People”



Call **800•344•2224**

and ask for
Bob Marino

- **New and Used Equipment Financing**
- **Competitive Rates and Terms**
- **No Hidden Cost/Simple Application Process**

- > Portable Restrooms > Video Inspection > Jetters
- > Service Vehicles > Industrial Vac Trucks

www.CenterCapitalCorp.com

Celebrating 26 Years of Loyal Service

*Center Capital Corporation is a subsidiary of Webster Bank, N.A., Member FDIC
All financing programs are subject to credit approval.



1000 Gallon Trailer Mounted Vacuum System



EXPERTS IN PORTABLE VACUUM SYSTEMS!

PACS 1000

PACS trailer mounted vacuum systems are available in a variety of configurations. PACS 1000 is designed for removing liquids, solids, and sludge from land or water. Costing less than vacuum trucks, the PACS is approved for highway towing. Integral hydraulics allow the PACS to run oil skimmers and pumps, as well as lift the tank to dump contents.

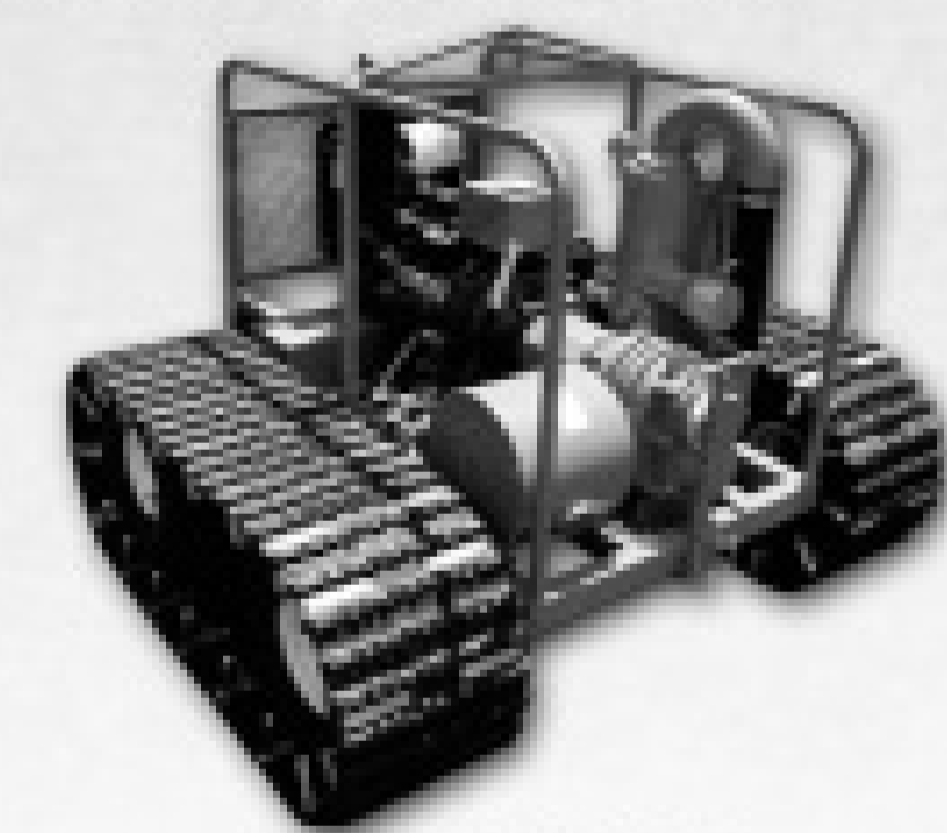

**ELASTEC
All Terrain Vac**

Oil Skimmer

Sucking up money for vacuum trucks

Our Drum Skimmers are optimal for rapid response oil cleanup. Extremely efficient and cost effective, they will give you an edge over competitors.



DrumIt

The drum filling vacuum head with auto shut off. DrumIt quickly connects to vacuum trucks for a clean interception of debris and liquids.



ELASTEC
AmericanMarine
Innovative Environmental Products

1309 West Main, Carmi IL 62821 USA
Tel: (618) 382-2525
Fax: (618) 382-3610
E-mail: elastec@elastec.com



www.elastec.com

PU10/08



DRAGON

PRODUCTS, LTD.

We Make It Happen!



Ask about our easy
Credit Terms and
Convenient Financing.



Insulated Stainless Steel Tankers
MADE IN THE USA!



Smooth Wall
V-Bottom Frac Tanks



Aluminum/Carbon Steel/
Stainless Steel
Vacuum Tankers



Vacuum Boxes
and Roll Offs



Aluminum/Steel
Bobtails and Pup Trailers



Centrifugal
Pumps,
Parts and
Service

email for more information:
sales@modernusa.com

877-778-4280

check out our website:
www.modernusa.com

A Modern Group Company

Jeremy Neer is general manager of Florida's Total Septic, founded in 1992 and owned by Jimmy Lapin. (Photos by Ed Wodalski)

A Winning SMILE

By Ken Wysocky

Florida's Total Septic uses a happy face logo and television advertising to drive home the company message of do-it-all customer service

Never underestimate the power of a distinctive, eye-catching business name and logo. For proof, look no further than the smiley faces on the vacuum trucks operated by Total Septic Service in Orlando, Fla.

The trademark smiley face, a play on an iconic 1970s pop culture symbol, appears on the rear of the Total Septic fleet. The vehicles also feature a simple, yet bold color scheme that includes the company's name in large block letters. The graphics all come together to help the company build brand recognition.

Owner Jimmy Lapin says a milk truck

inspired the smiley face concept.

"On a miserable, hot August day, I was sitting behind a milk truck with a smiley face on the back — no name, just a smiley face," he says. "It made my day to see that face. I couldn't wait to get even with the truck to see the name of the company."

"People call all the time and ask if we're the company with the smiley face on the back of our trucks," says Lapin's daughter, Nichole Margeson, the company's office manager. "It works — people really remember us. Those trucks are moving billboards."



A trademark smiley face appears on the rear of Total Septic's fleet.

Lapin almost ran into legal issues with a large retailer, which asked him to "cease and desist" using his original logo because it was too similar to the retailer's own "falling prices" logo. So Lapin made the smiley faces' eyes look downward to the right, which appeased the mega-corporation.

As for the company name, Lapin wanted something that would simply and clearly state what the company was all about. A small epiphany occurred one day at his kitchen table.

"We do anything that has to do with



Diesel mechanic Anthony Hall repairs an engine on a Total Septic truck. All repairs are done in-house, saving time and money.

“I ALWAYS WANT GOOD RAPPORT WITH MY COMPETITORS. IF WE HAVE OVERFLOW WORK, WE GIVE IT OUT TO OTHERS. THEN IF THEY HAVE OVERFLOW WORK, THEY’RE MORE LIKELY TO SAY, ‘HEY, GIVE JIMMY THAT JOB.’ IT WORKS OUT FOR ALL OF US ... INSTEAD OF WORKING AGAINST EACH OTHER AND BEING CUTTHROAT ABOUT IT.”

Jimmy Lapin

TO VIEW TOTAL SEPTIC SERVICE COMMERCIALS AIRED IN THE ORLANDO, FLA., MARKET, GO TO YOUTUBE.COM AND SEARCH FOR TOTAL SEPTIC COMMERCIAL.

water,” Lapin says of his company, established in 1992. “Our motto is, ‘If water flows thru it, we do it.’

“One morning, I was eating Total cereal for breakfast,” he says. “I immediately thought of our company ... the name says it all.”

TELEVISION ADVERTISING

Recognizable trucks are just one way Total Septic gets the word out about its services, which include septic pumping, drain cleaning and drainfield installations. The company’s multimedia marketing campaign also includes television commercials, which Lapin estimates generate about 12 percent of his business volume (about 60 percent septic pumping, 20 percent stormwater drain cleaning, 10 percent commercial and home drain cleaning and 10 percent drainfield installations).

Lapin writes the commercial scripts and a local television station produces them. Although he has no formal marketing or scriptwriting experience, Lapin says he understands promotion.

“It just comes naturally,” he says. “You just

tell people what they need to know — how our company can upgrade customers to today’s operating standards.”

So far, Lapin has developed three 30-second commercials, all aimed at the residential and commercial pumping market. Each one costs about \$20,000 to produce and \$130,000 to broadcast about seven or eight times daily for a year.

“I saw a plumber running commercials and felt we should give it a try,” he says. “We were told the commercials made a 10 percent difference in the plumber’s business.”

Because of the economic downturn, Total Septic is cutting back to running spots twice a day. But Lapin is still bullish on television advertising, noting that the company’s telephones “started ringing off the hook” after the commercials started running.

Lapin believes the commercials augment a word-of-mouth reputation established by his more-than-30-years-experience in the industry.

“We do little things, like hand-rake after every (installation) job,” he says. “And we

don’t leave tractor ruts everywhere. When we leave, the ground is ready for sod. A landscaper might charge you big bucks to rake out and level your yard.”

BIGGER NOT ALWAYS BETTER

Over the years, Lapin has learned one important business lesson: Growth isn’t always good. In fact, when it comes to generating a profit, less is sometimes more, as the saying goes.

“Bigger isn’t always better, believe me,” Lapin says. “The best (sales) year I ever had, I didn’t even make a profit because I had such a high payroll. When you’re running a large business, you’ve got to have a serious infrastructure of good supervisors in place, otherwise you have one guy running 65 men. After a while, it gets to be too hard to handle.”

Difficulty in collecting payment from customers further complicated the situation. Sobered by the lack of profits and overwhelmed by the logistics, Lapin did some serious downsizing, concentrating on septage pumping services and turning down work

Profile

Total Septic Service Orlando, Fla.

Owner: Jimmy Lapin

Founded: 1992

Employees: 29

Services: Septic pumping and installations, residential and commercial drain cleaning and industrial waste hauling

Service area: Central Florida and portions of southern Florida, plus greater Charlotte, N.C.

Web site: www.totalseptic.com



At left, Scott Thompson, a retired health department official, is the company’s geotech expert. At right, owner Jimmy Lapin and his daughter, Nichole Margeson, discuss a TV commercial that Lapin wrote.



Technician Eddie Parks updates a customer on the condition of his septic system during a morning pumpout near Orlando.



related to new construction. The move paid dividends: Compared to five years ago, Total Septic's sales volume is about half of what it used to be — but the company now turns a profit, and Lapin is a saner man.

"Not being able to collect money was the straw that broke the camel's back," Lapin says. "Now I ask for half payment upfront, so that at least pays for materials. If you can't pay for materials, you won't survive very long."

DISPOSAL ISSUES

Lapin also has learned to keep a sharp eye on waste disposal costs, and he changes disposal methods when it makes sense financially. For example, he land-applied septage for

years because it was cheaper than taking it to treatment facilities. Now, taking advantage of transportation savings, he relies on the nearby Orange County sewage treatment plant for waste disposal.

One of the biggest challenges Total Septic faces is grease trap waste disposal. The Orlando area is densely populated with restaurants, which creates high demand for grease trap cleaning. But Orange County doesn't accept grease trap waste, a situation Lapin is actively lobbying with county officials to change.

At present, Lapin disposes grease trap waste at a private processor he views as a business competitor.

A FLEET FOR DIVERSIFIED SERVICE

Lapin believes business diversity is critical to his company's success. The company offers a full array of septic services, including installations and certified inspections. Its services also include handling industrial waste, cleaning industrial plants, cleaning and repairing sewer lines and lift stations, video drain line inspections, and commercial and residential drain cleaning. Lapin estimates the company's sales volume is split 50/50 between commercial and residential work.

Geographic expansion has also keyed company growth. Total Septic operates loca-

tions in West Palm Beach and Jupiter, as well as Charlotte, N.C.

A wide array of services demands a large stable of equipment. On the pumping side, Lapin builds out his own trucks, using steel tanks from Modern Welding Company Inc. Total Septic runs four Mack R trucks (1979, 1989, 1994 and 1998) with 3,500-gallon

Lapin Embraces the Competition

Befriending competitors makes good business sense, says Jimmy Lapin, owner of Total Septic Service in Orlando, Fla.

"I always want good rapport with my competitors," he explains. "If we have overflow work, we give it out to others. Then if they have overflow work, they're more likely to say, 'Hey, give Jimmy that job.' It works out for all of us ... instead of working against each other and being cutthroat about it."

If competitors aren't receptive to Lapin's share-the-wealth philosophy, he doggedly persists until he wins them over.

"If people keep pushing me off, I just keep going back to them," he says. "If you keep shaking their hand, after a while they'll give up because you're a nice guy."

Lapin says his friendly attitude stems from his upbringing in a large Polish family where raucous get-togethers were the norm. Lapin's grandfather, whom he worked with for a time, also believed strongly in embracing competitors.

"Even if a competitor doesn't want to do business with us, we still help out if they need it," Lapin says. "That was my grandfather's attitude. It all comes back to you eventually."



Pump truck technician Bryan Warren fills out a waste disposal manifest. Orange County requires all septic companies to fill out the form, which must have the customer's signature, waste hauler's signature and a signature from the waste processing facility.

tanks; a 1997 Mack R truck with a 4,000-gallon tank; and a 1990 Mack R pump truck with a 4,500-gallon tank. For commercial drain cleaning, Total Septic owns a 1991 Vactor truck with a 2,000-gallon waste tank and a 1,200-gallon freshwater tank, built by Jack Doheny Companies; and a 1998 Vactor truck with a 2,000-gallon waste tank and a 2,200-gallon freshwater tank, built by Environmental Products of Florida.

DEEP ROOTS IN THE INDUSTRY

Lapin comes from a long line of pumpers. His grandfather, George Lapin, started AAA Septic in 1959. His uncle, Dennis Lapin, established Lapin Septic Tank Service Inc.

Jimmy worked for his grandfather then worked for his uncle for about 11 years, establishing a pumping division for the company, which before had focused on installations. Then he split off to start Total Septic.

"I never looked back and he never looked back, and we're the best of friends," Jimmy Lapin says.

Nichole Margeson represents the fourth generation of Lapins to work in the septic industry, which underscores Total Septic's standing as a family-run company guided by family principles.

"We just treat people good — like we'd want to be treated," Lapin says.

And, of course, make them smile. ■

MORE INFO:

Environmental Products of Florida

407/798-0004
www.epofc.com

Jack Doheny Supplies Inc.

248/349-0905
www.dohenycompanies.com

Vactor

815/672-3171
www.vactor.com

CAPITAL RUBBER CORP

Get Connected.

WEATHERFLEX EPDM

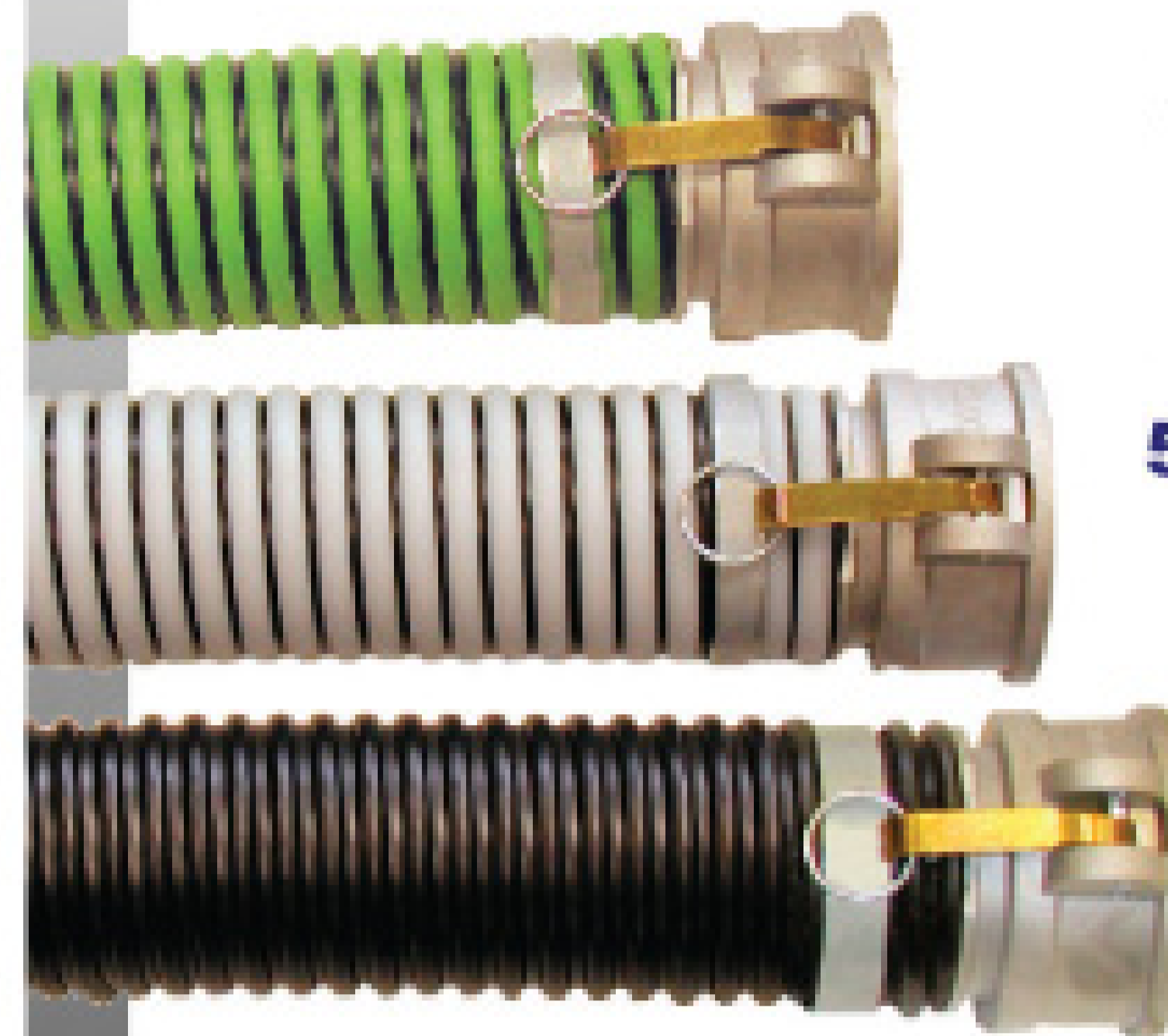

**4 INCH HOSE
OVERSTOCK SALE!**
GREEN AND BLACK EPDM
25 FT COUPLED: \$ 150
50 FT BULK HOSE: \$ 210

**3 INCH HOSE
EVERYDAY SPECIAL!**
25 FT: \$ 102.50
33 FT: \$ 129.50
COUPLINGS INCLUDED!

POWER BOOSTER

INCREASE VERTICAL LIFT



- INCREASE:**
- CAPABILITY
 - POSSIBILITY
 - PROFITABILITY

PATENT-PROVEN DESIGN ALLOWS YOU TO HARNESS THE POWER OF A COMPRESSED AIR OR WATER SOURCE TO SIGNIFICANTLY INCREASE THE PERFORMANCE CAPABILITIES OF YOUR VACUUM TRUCK!

PUT IT TO THE TEST

NEW REDUCED PRICES ON:

- LEVER VALVES
- PISTON VALVES
- SAFETY BUMPS



CALL FOR FREE CATALOG

845 N DILLON DRIVE
WOOD DALE, IL 60191

(800) 258-3000



WWW.CAPITALRUBBERCORP.COM

Steel Tanks



Polished Aluminum Skirting and Tool Boxes

- 2009 Dodge 5500, Cummins Diesel, Automatic, 19,500 GVW, 1000 Waste, 300 Fresh
New 4x2 \$62,500
New 4x4 \$65,500
- 2008 GMC 5500, Duramax Diesel, Allison Automatic, 19,500 GVW, 1000 Waste, 300 Fresh
New \$59,000
- 2007 GMC 5500, Duramax Diesel, Allison Automatic, 19,500 GVW, 1000 Waste, 300 Fresh, Miles in 40,000
4 Trucks Available \$48,000 each

Aluminum Tanks



by Amthor 5/16" Thick

- 2009 Dodge 5500, Cummins Diesel, Automatic, 19,500 GVW, 1000 Waste, 400 Fresh
New 4x2 \$71,500
New 4x4 \$74,500
- 2008 GMC 5500, Duramax Diesel, Allison Automatic, 19,500 GVW, 1000 Waste, 400 Fresh
New \$68,000
- All Brand Trucks Available
- New Septic Trucks Available
- Used Septic and Toilet Trucks Available

Portable Restroom Trailers



Trailer Mount Slide-in Tank

600 gallons waste/200 gallons fresh water.
\$13,500



8 RESTROOM | 10 RESTROOM | 12 RESTROOM | 14 RESTROOM | 16 RESTROOM | 20 RESTROOM

SLIDE-IN UNITS & USED TRUCKS AVAILABLE / MASPORT, JUROP & CONDE VACUUM PUMPS

CHECK OUR PRICES

LANE'S VACUUM TANK, INC.

3133 VANZORA RD. • BENTON, KY 42025

800.592.3308 • 270.527.9945

RODNEY LANE'S CELL 270.832.3793

We stand behind our trucks and trailers!

Aluminum & Steel **IN STOCK!** www.KeeVac.com New, Used & Refurbished

Coming Soon *progress tank* Stainless Steel

1700 Gallon Restroom Tank
Dual service, Low work station.
2008 Kenworth 300 Series
22,000 G.V.W, auto. trans.

Under! \$75,000



Two Year Warranty

2002 Freightliner FL112 - CAT C-10
NEW! 3600 Gallon - Masport 400 CFM

Under! \$85,000

2000 Gallon Restroom Tank
Masport HXL4 standard pumping
system, dual service.

2009 Hino Model 268A
Auto trans., Hyd. brakes,

Under! \$85,000



KeeVac
Industries Inc.

866-789-9440

Complete **'IN STOCK'** Work-Ready Factory Assembled Units!
Let Us **SAVE YOU \$\$\$** On Your Next New Vacuum Service Truck!

FINANCING
DELIVERY
CUSTOM BUILDS



PORTA-JOHN UNITS



STAINLESS STEEL & STEEL UNITS -
CALL FOR INFORMATION



TANKS TO YOUR SPECIFICATIONS

PUMP DISTRIBUTOR

- * BATTIONI
- * JUROP
- * BOWIE
- * MASPORT
- * FRUITLAND
- * MORO

Pump Rebuild Kits In Stock

**CALL TODAY FOR
INFORMATION
OR PRICES ON
TANKS, PUMPS
AND ALL PARTS**

Secondary Shutoffs

Sight Glasses, Valves & Couplings

12" Primary Shutoffs

21" & 36" Manways

BASE TANKS INCLUDE:

1/4" Thick Steel • Pipe Reinforced Baffles • Primary Shutoff
Flanged and Dished Heads • 21" Top and Rear Hatches
Full Length Under Carriage on Bottom of Tank

BASE TANK PRICING

2100 GALLON	\$5800	3360 GALLON	\$8140
2500 GALLON	\$6740	3570 GALLON	\$9000
3000 GALLON	\$7575	4000 GALLON	\$9920



800.364.7307

2100 EAST BOOTH ST. • SEARCY, AR 72143
Fax: 501.279.0003 • E-mail: sbs@cdlworld.net

PERFORMANCE

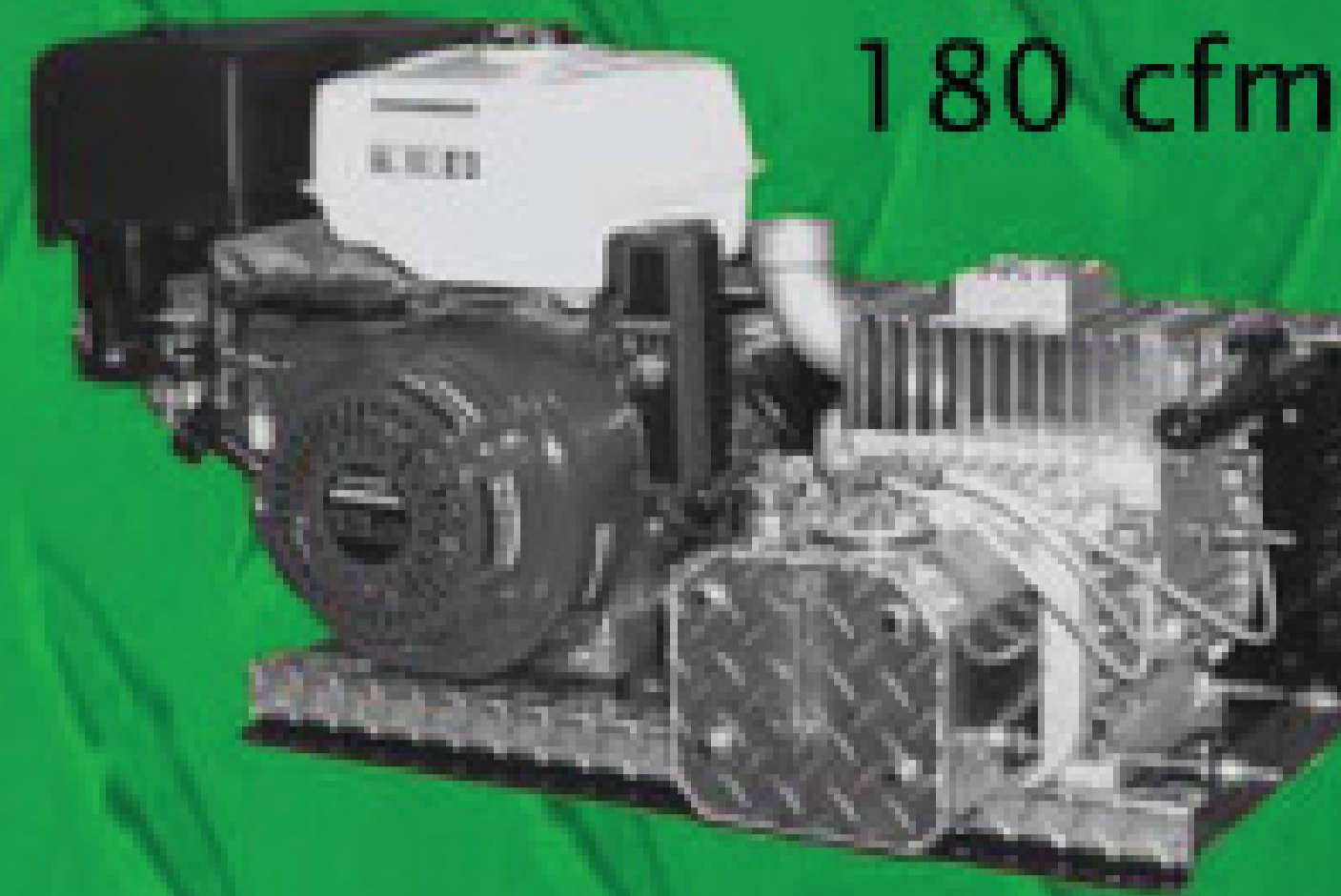

RELIABILITY

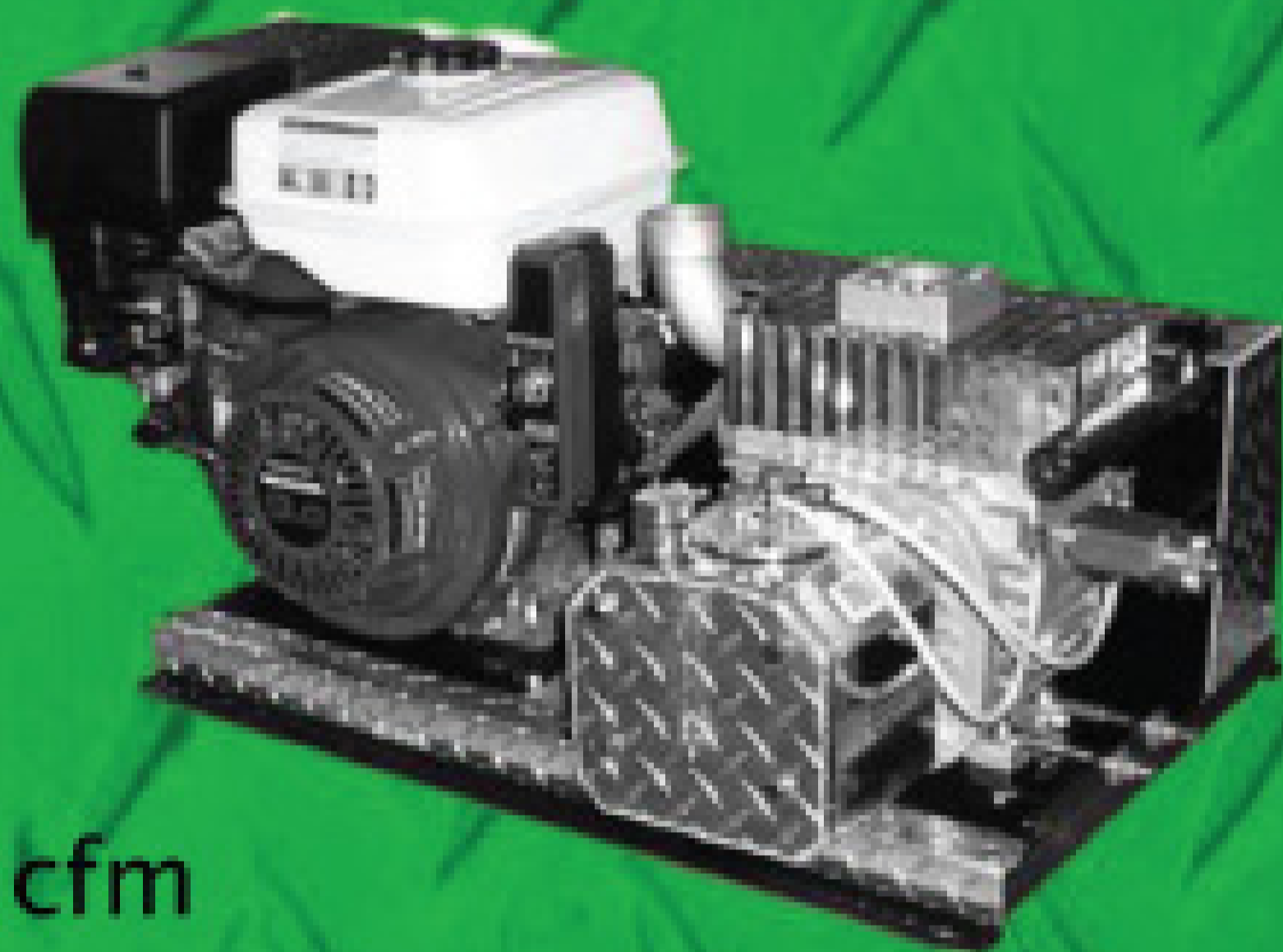

PROVAC



Ideal for Grease Traps



QUALITY

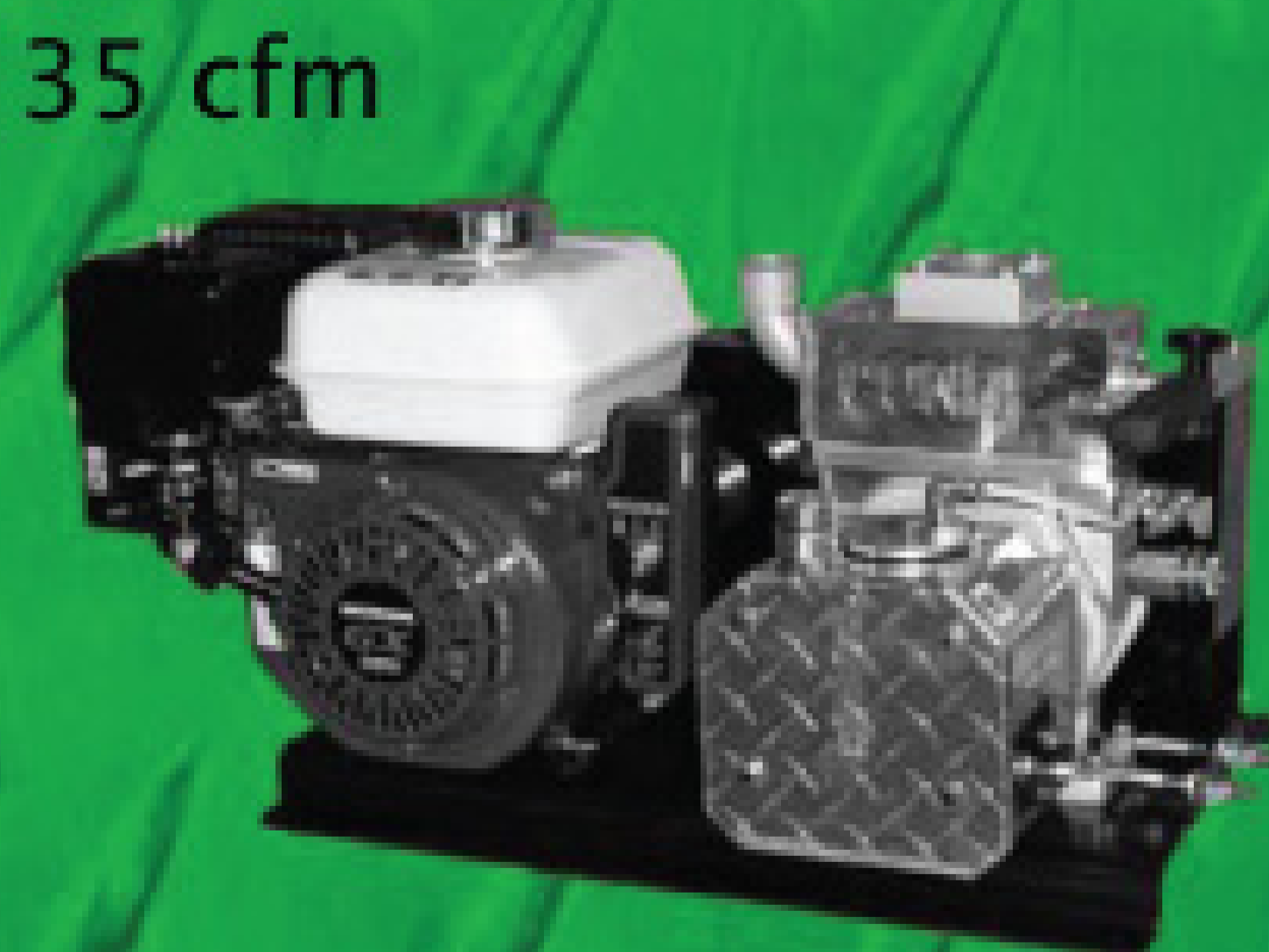

Westmoor, Ltd

PO Box 99, Sherrill, NY 13461

800-367-0972

**DOWNLOAD
OUR CURRENT
CATALOG!!!!**

www.westmoorltd.com

MADE IN AMERICA

Dewatering Containers



Bakers Waste Equipment Inc (BWE) designs and manufactures dewatering sludge containers which are specified to provide septic and grease haulers onsite waste processing capabilities.

Filter Panel Structures are available in stainless steel, galvanized, or mild steel with chemical resistant protective coatings on the substructure.

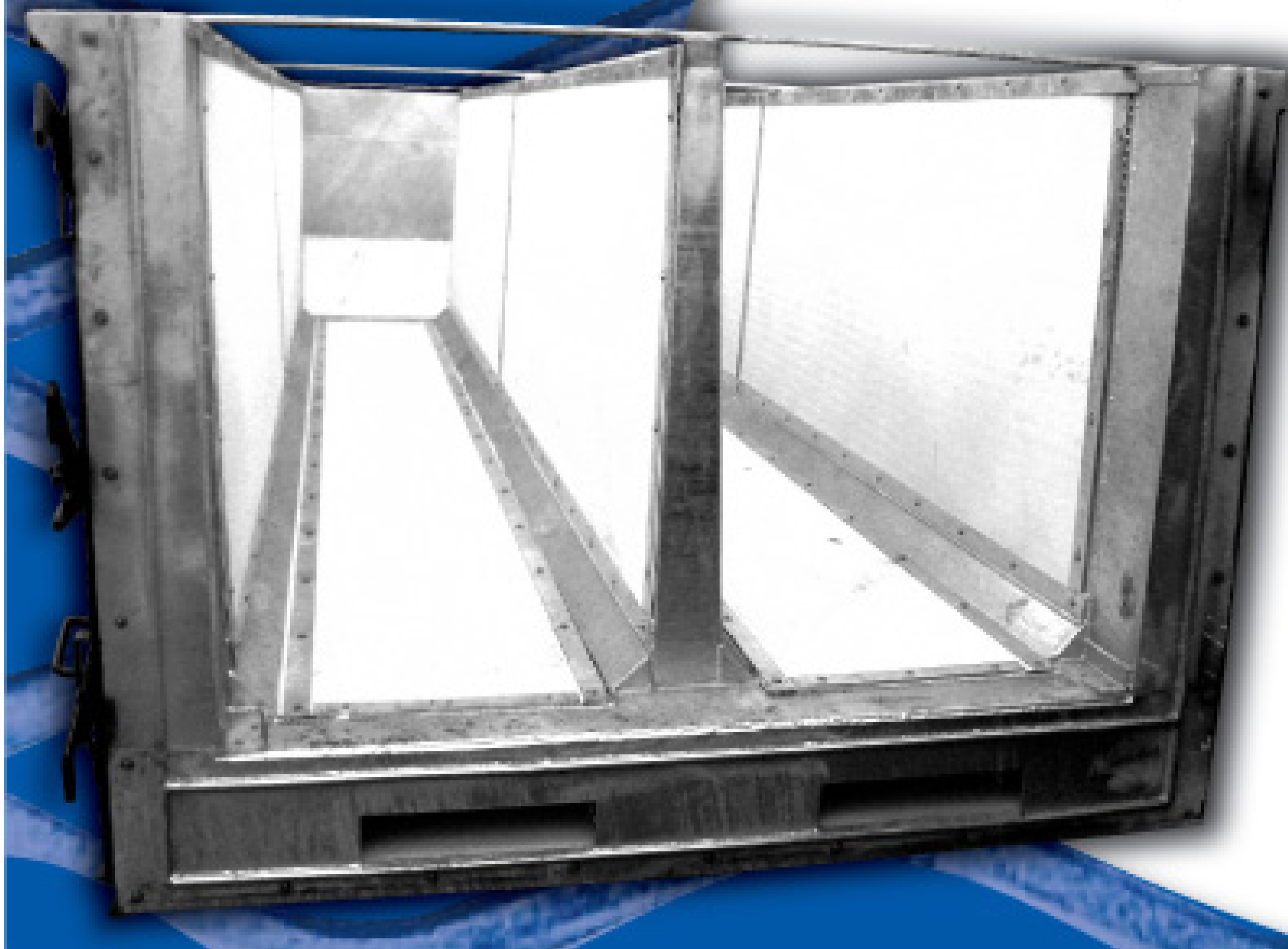

Standard Specifications Include:

Capacities in 15, 20, 30, and 40 cubic yard designs
 Heavy Duty Construction
 Processing Rates from 15,000 to 25,000 Gallons Per Day
 Internal Center Wall Provides Dual Compartments for More Efficient Filtration and Separation of Waste.

Designs Available with Permanent (330 Micron) or Disposable Filter Media
 (3) Ratchet Closures on Sealed Sludge Gate
 Cable Lift or Hook Lift Capabilities

BWE
 BAKERS WASTE EQUIPMENT

800/221-4153
828/879-8222
828/879-8557 fax
www.bwe-nc.com

Irrigation fittings are for irrigating – NOT vacuum.
 How many dollars are you spending
SUCKING AIR?
 Industry-proven, quality vacuum couplings from
 Bandlock will put money into your pockets.



4" to 12" Male Coupler



Steel Crown 4", 6" and 8" Press End



Hazardous Material Profile Gaskets (Safety)



4" to 12" Female Coupler



4" and 6" High Aluminum Bulk Nozzles



Rubber Gaskets

Recognized as the #1 Relief Valve in the World

CLOSE TOLERANCE COUPLERS AND FITTINGS BRING "SAFETY" TO YOUR WORK PLACE.

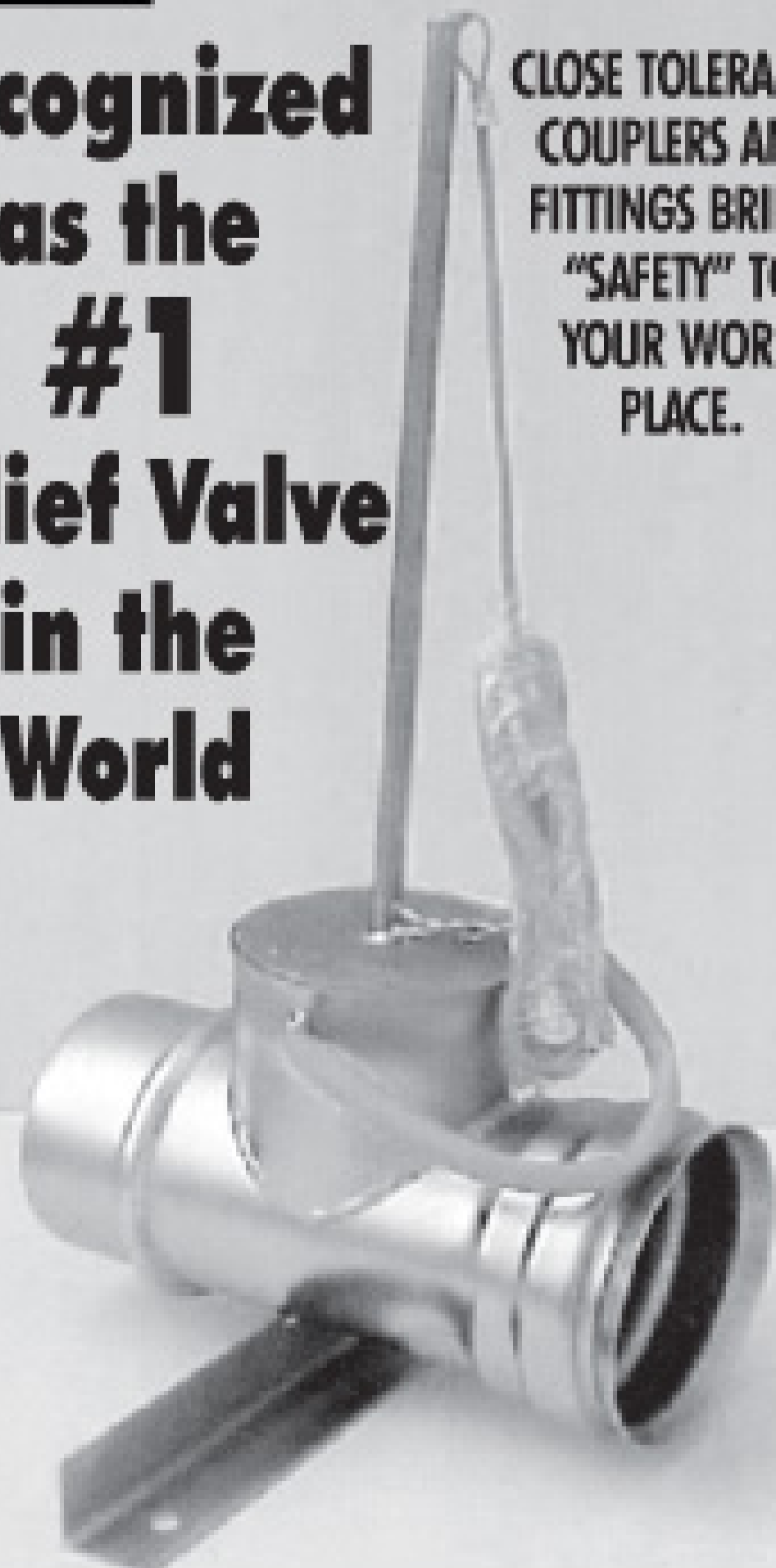

BANDLOCK Corp.

MADE IN THE U.S.A.

Call or fax today to get your catalog!
1-800-659-2978
Fax: 909-930-2551
www.amesbury.com

SUPERIOR "QUICK" CONNECT VACUUM AND PRESSURE COUPLINGS AND ACCESSORIES



6" and 8" Aluminum Weldon



Special "Y" Reducers



BANDLOCK "Y"'s



Aluminum & Steel Pipe



BANDLOCK Reducers

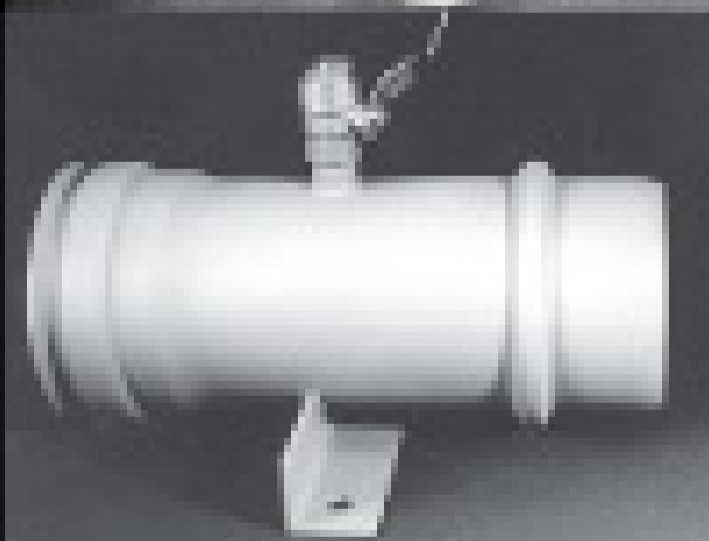

Wet Valve, 6", 360° Injected



Male and Female 4" to 12" End Plugs



EZ Lift Clamps



Standard & Internal 4" to 12"

WHAT'S THE DIFFERENCE BETWEEN A BULLET AND A SLUG?



DriPax, THROW AND GO DEODORIZER. IT'S ALL ACTION!

Those bullets streaking down the highway can be your trucks when you use new DriPax throw and go deodorizer. No more messy liquids, no more awkward measurements, no half dissolved tablets and packets, no delays. Just pure deodorizing power in a 100% biodegradable portion controlled pack. DriPax is all action - no fillers. It's the difference between a bullet and a slug.

Aim to get your free samples now. Call (800) 241-7951.



99 Crafton Drive, Dahlonega, GA 30533 USA • Phone (800) 241-7951 or (706) 864-3776 • Fax (706) 864-8111 • www.polyportables.com

Only PolyPortables offers high-performance Green Way Products

TOILET DEODORIZERS • TOILET CLEANERS • AIR FRESHENERS • INSECT REPELLANT

All Green Way deodorizers, cleaners and air fresheners are earth-friendly, people-friendly products. They are developed and manufactured in our facilities in Dahlonega, Georgia by Green Way Products, a PolyPortables sister company.



ANSWERING THE CALL

An industrious family celebrates 40 years of pumping tanks and making friends in their Maryland hometown

By Ken Wysocky

In 1969, John E. Call established John's Septic Tank Service in Aberdeen, Md., with little more than a 1957 Dodge 1 1/2-ton truck equipped with a homemade, 1,000-gallon steel tank — and enough integrity and old-fashioned work ethic to fill it many times over.

"To pump out septic tanks, he'd hook up a hose to the engine intake manifold," says his son, John R. "Honest John" Call, who now owns the business with his wife, Gloria. "It took about 10 minutes to build up enough vacuum to pump out the tank. Sometimes the ball float that cut off the vacuum when the truck tank was full would get stuck, and liquid would get into the engine and seize it up.

"Then I'd have to take out the spark plugs and turn the engine over to pump water out of the cylinders," he continues. "We had to do that many, many times. He always had a fresh set of spark plugs stored behind the driver's seat."

A lot about the pumping industry has changed since then, and the Call family has made adjustments to better serve their market along the way. This year, the family celebrates 40 years in business and is ever vigilant in adapting to make sure they can be around for 40 more if they so choose.



At right, John R. Call and John R. Call II with their dog Luke. Above, the Calls team up to remove a manhole lid at a local church. (Photos by Shannon Zirkle)



Profile

John's Septic Tank Service
Aberdeen, Md.

Owners: John and Gloria Call

Founded: 1969

Employees: 4

Specialties: Residential septic pumping and grease-trap cleaning

Service area: Harford, Cecil and Baltimore counties

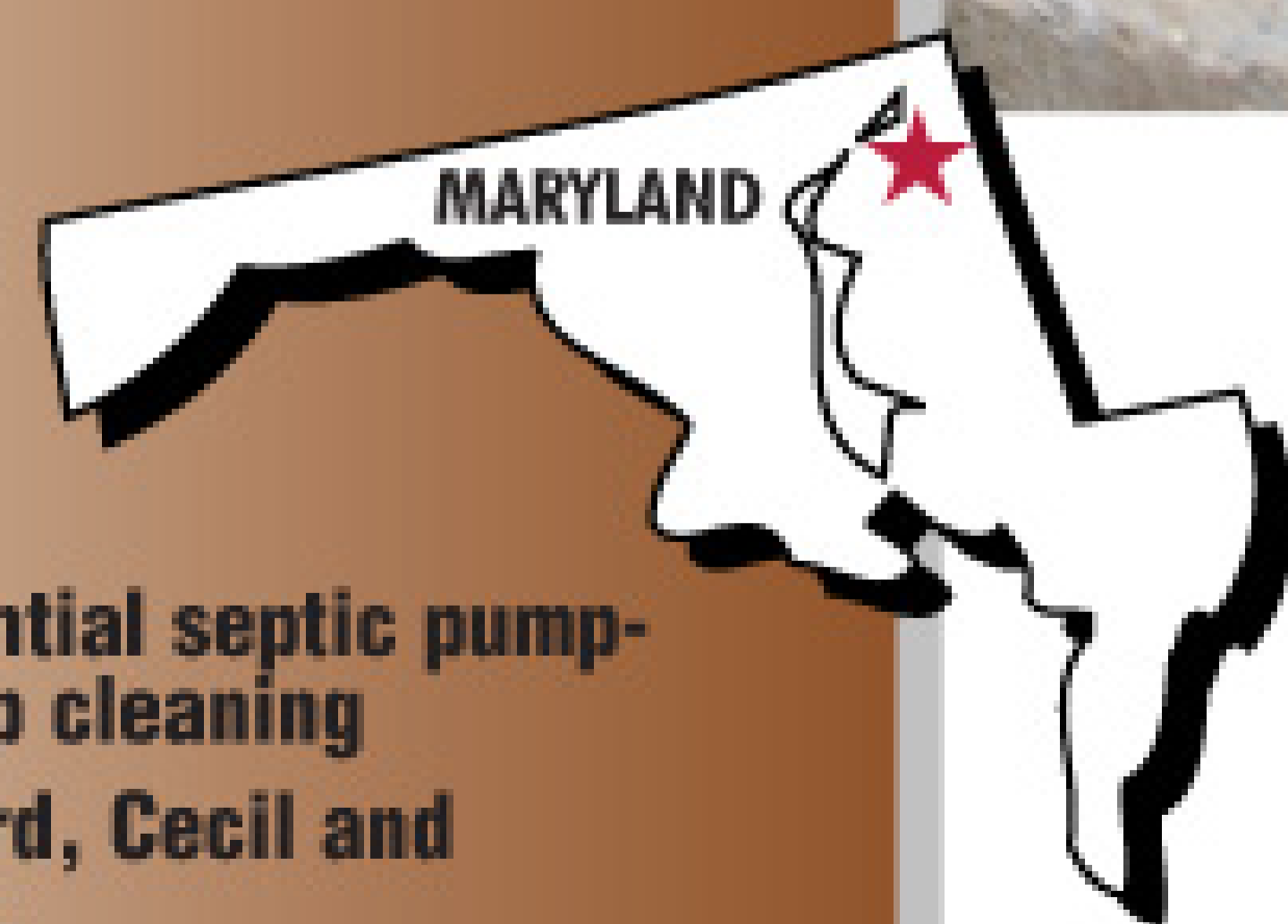



John's Septic team members (from left) include owners John R. and Gloria Call, their son, John R. Call II, Joel Garvin, Kimberly Call and Elma VanHorn.

WE'VE COME A LONG WAY

The primitive equipment the company used in the beginning shows just how far they've come. That old truck with the manifold vacuum setup is a far cry from the gleaming trucks the company relies on today: a 2002 and 2007 Peterbilt 330, each equipped with 2,400-gallon steel tanks and Masport 400 pumps; and a 2005 Ford F-750 with a 2,400-gallon tank and a Masport 400 pump. Abernethy Welding & Repair Inc. outfitted all three trucks.

"These modern trucks have tripled my productivity since I took over the business," Call says. The company's business mix is about 60 percent residential septic tank

cleaning and 40 percent grease trap cleaning.

While the truck technology has changed radically, one thing has always remained steadfastly the same at John's Septic through three generations of family involvement: an unswerving commitment to hard work, honesty and customer service.

"I've been doing this since I was 17 years old," says Call, who bought the business from his father in 1987. "My father instilled in me the ethic of treating people like I want to be treated. That's been our business philosophy for all these years."

When Call bought the business from his father, he took steps to modernize the company's equipment. He started by buying a used

"I PROBABLY CHARGE A LITTLE BIT MORE THAN SOME BECAUSE I THINK MY 40 YEARS OF EXPERIENCE IS WORTH SOMETHING, NOT TO MENTION THE HOURS WE PUT IN SEVEN DAYS A WEEK. THERE'S ALWAYS NEW GUYS STARTING UP AND CHARGING LESS. BUT WE STICK TO OUR GUNS. YOU GET WHAT YOU PAY FOR."

John R. Call

1978 International vacuum truck with a 1,500-gallon tank.

"Even with that truck, we could only pump about one and a half septic tanks before we'd have to go dump the load, then come back and finish the rest of the second tank," says Call's son, John R. Call II. "We couldn't even do two full septic tanks with it."

In 1990, the Calls upped the ante and became one of the first septage pumpers in the area to invest in a 2,200-gallon tank, built onto an International 4300.

PARTED WITH HARLEY

"Dad wanted to build up the company so bad that he gave the dealer his 1977 Harley-Davidson motorcycle as a down payment on the truck," says Call II. "The dealer promised not to sell it until Dad came back with some cash. But by the time Dad went back, the bike was gone."

From the early days of John's Septic, founder John E. Call is shown installing a residential septic system.



YOU DIG, WE PUMP: Two families work hand-in-hand for three generations

The strong family ties that bind John's Septic Tank Service in Aberdeen, Md., also extend to an old family friend, Dan Curry, who along with his brother, Yogi, owns AM Curry Excavating Inc., located in nearby Havre de Grace.

The Calls and the Currys have been sending business each other's way for decades, starting with Dan's father, Charles, and John E. Call, who founded John's Septic.

"We both bought our fathers' businesses the same year, and we've worked together for more than 30 years," John R. Call, the current owner of John's Septic and John E. Call's son, says of his long-standing relationship with Curry. "Danny does excellent work and keeps his equipment in excellent shape. I know he's not going to be leaking oil or hydraulic fluid all over someone's place while he's working."

"If we come across a metal tank that's falling in, we call him to give a price (for digging it out)," says John R. Call II, the son of John Call. "And if he's doing a repair, he calls us out to first pump out the tank, so he can work."

"It's unusual for people to stay in business with each other for so long," he adds. "Many relationships like this end up with both sides arguing over money. But Dad and Danny have always been able to work things out and keep each other happy."

The three-generation family business celebrates its 40th anniversary this year. In this photo taken in the early days of the business, the late John E. Call is shown with his son, John R. Call, and his grandson John R. Call II.

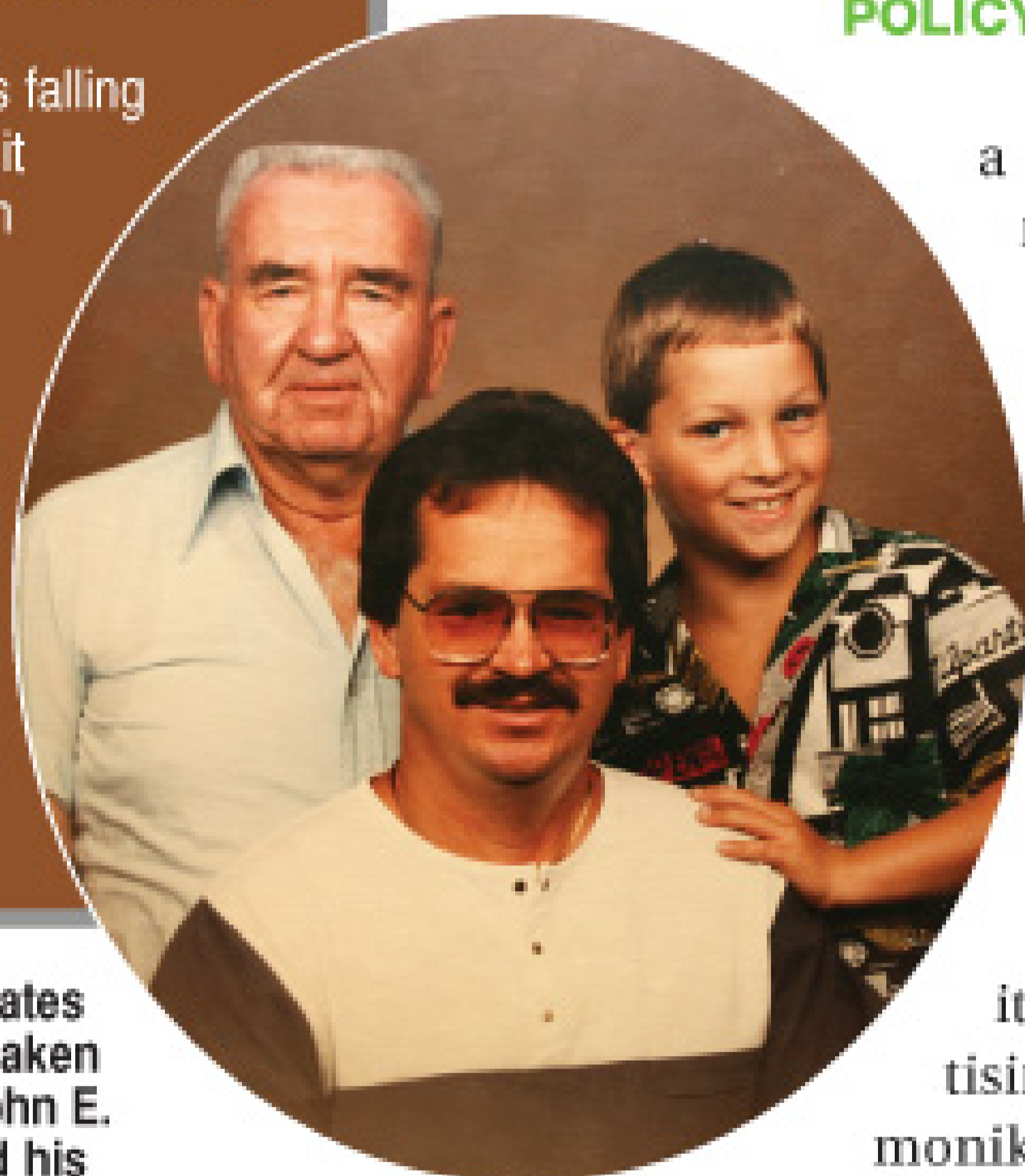

"That was real painful for me — Dad used to take me on rides on it," Call II says.

Adds his father: "I had just restored the bike. John cried because he couldn't believe I was selling it."

Now the Calls are eyeing a 3,200-gallon capacity pumper truck, prompted by a new ordinance in Harford County that requires two-compartment, 1,250-gallon septic tanks on all newly built homes.

"They think (the dual-chamber setup) will improve the effluent going to the drainfield," Call II says of the tighter regulations on septic tanks. "It makes each job harder because there are two manhole covers now. We put one hose in the tank and pump out the sewage, then we reverse the pump and backflush the tank."

"With a 3,200-gallon vacuum tank, we'd be able to pump out two full (1,250-gallon) tanks, or three older 1,000-gallon septic tanks at a time."

"WE LOVE OUR JOBS — NEITHER OF US MIND GETTING UP IN THE MORNING FOR WORK. I'VE BEEN DOING THIS SINCE I WAS 17 YEARS OLD, AND JOHN WAS EIGHT OR NINE YEARS OLD WHEN HE STARTED RIDING IN THE TRUCK WITH ME. ALL I KNOW IS THAT WE PROVIDE A SERVICE FOR PEOPLE, AND THEY'RE ALWAYS GLAD TO SEE ME."

John R. Call

Call's philosophy on maintaining a fit fleet is simple: Keep the service vehicles in tip-top shape, but trade them in as soon as they start nickel-and-diming the company with repairs.

"I like to trade them in while they're still looking good," he says. "Image is everything in this business."

HONESTY — THE BEST POLICY

Years ago, a friend who runs an excavating business, Dan Curry, nicknamed Call "Honest John." The name stuck, and the business now uses it in its local advertising. The moniker reflects

Call's philosophy of always doing what's best for customers — even if it costs the company money.

"If I get to someone's house and find the tank doesn't need pumping, we tell the owner that," Call says. "Or if there's a clog in the outlet at the back of the tank, I tell them that if they're not afraid to use a shovel, they can dig down to the distribution box themselves and run a garden hose through it. If that doesn't work, then I'm happy to fix it."

"We don't want people to spend more money than they have to," he says. "That kind of honesty pays off in the long run."

That doesn't mean Call's prices are lower than needed, however.

"I probably charge a little bit more than some because I think my 40 years of experience is worth something, not to mention the hours we put in seven days a week," he says. "There's always new guys starting up and charging less. But we stick to our guns. You get what you pay for."

"For instance, I check everything out

before I stick a hose in a tank, and if I find a problem, I let the homeowner know," he explains. "If they aren't home, I write it down on the invoice."

STANDING PAT

John's Septic doesn't adhere to a bigger-is-better philosophy. Call learned a valuable lesson in that regard about 10 years ago, when he entered the portable restroom field.

"We had 100 restrooms, but it was too time consuming," Call says.

"We did it for about four years," Call II adds. "With just the two of us running trucks, there was no time for anything else. We'd be delivering restrooms on Friday nights for parties, then miss church on Sunday morning to go pick them up. It was just too much to do."

"What we have now meets our needs," he says. "We have a house and my parents have a house. We have enough money to take care of us."

Above all else, the elder Call relishes the fact that he and his family are keeping alive the legacy his father built. He says his business base includes many people who've been faithful John's Septic customers since the 1960s, and who fondly recall his father, who worked until he was in his 70s and lived to be 93 years old. The long family history makes working with his son even more special.

"It's a wonderful blessing that John works with us," Call says. "We love our jobs — neither of us mind getting up in the morning for work. I've been doing this since I was 17 years old, and John was eight or nine years old when he started riding in the truck with me."

"All I know is that we provide a service for people, and they're always glad to see me."

Adds Call II: "We just do the best job we can. People always tell me how good my grandpa was and how good my father is, so I feel obligated to live up to that standard."

And keep on preserving a proud family tradition. ■

MORE INFO:

Abernethy Welding & Repair Inc.
800/545-0324

Masport Inc.
800/228-4510
www.masportpump.com



VAC-CON

PRE-OWNED EQUIPMENT

MORE POWER TO YOU



2005 VAC-CON V321LHAD

- 2005 IH 7600
- CAT C-13 380 HP / 10-SPD
- 50 @ 3000 / DEUTZ 138 HP
- Mileage: 31,000

\$195,500



1997 VAC-CON V312THAE/1300

- 1997 Ford LNT8000
- 275HP / MD3060
- 50 @ 3000 Water Pump
- Mileage: 66,703

\$105,000



2000 VAC-CON V312LHA

- 2000 Sterling LT7501
- CAT 275 HP / Allison MD3060
- 60 @ 2000 / Cummins B3.9
- Mileage: 27,115

RECONDITIONED \$138,000



2006 VAC-CON VPD4212LHAE

- 2006 IH 7400
- IH 285 HP / Allison 3000RDS
- 80 GPM @ 2000 PSI / DEUTZ 138 HP
- Mileage: 82,000km

\$205,000



2006 VAC-CON V312LHAD

- 2007 STERLING LT7501
- CAT 275 HP / Allison 3000RDS
- 50 @ 3000 / DEUTZ 138 HP
- Mileage: 23,000

\$209,500



2000 VAC-CON VPD3609SHA

- 2001 IH 2654
- 275 HP / Allison MD3060
- 60 @ 2000 / John Deere 4045T
- Mileage: Approx 45,000

\$145,000



2001 VAC-CON V312LHAD/1300

- 2001 Sterling LT9501
- CAT 380 HP / 10-Speed
- 80 @ 2000 / Cummins 110 HP
- Mileage: 73,000

RECONDITIONED \$185,000



2004 VAC-CON V311LHAD

- 2004 Sterling LT7501
- CAT 275 HP / Allison MD3060
- 65 @ 3000 / DEUTZ 138 HP
- Mileage: 88,200

RECONDITIONED \$195,000



www.vac-con.com



Ultimate Lease Hotline:
888-817.1757

969 Hall Park Drive • Green Cove Springs, FL 32043 U.S.A.
Tel: 904-284-4200 • Fax: 904-284-3305
www.vac-con.com • vns@vac-con.com



GET MORE JETTER FOR YOUR DOLLAR!

We include all the options, others charge extra!

UVJ Models
5 gpm @ 4000 psi
Cold Water \$5995
Hot Water \$7995

NEW Models



Don't see what you want?
We do custom fabricate!

Fully Loaded Models
7 gpm @ 4000 psi \$10199
11 gpm @ 2500 psi \$11999
15 GPM @ 3000 psi \$18399
20 gpm @ 2000 psi \$ 19999
18 gpm @ 4000 psi \$37899



See our complete lineup from economy models, van mounts, portables and more on the web at:

www.camspray.com 800-648-5011

Agribusiness Supply Company

800-881-6720

Call us for a free catalog!



Metaltecnica Lever Valves
Metaltecnica Piston Valves
(Threaded and Flanged)
Hydraulic and Air Cylinders
Italian Fittings
Secondary Shut-Offs
Camlock Hose Couplings
Superex Super T-Bolt
Hose Clamps
Vacuum Tank Accessories



5719 Westminster Dr., Suite E
Cedar Falls, IA 50613

ARMSTRONG EQUIPMENT INC.

MODEL 806B SEELEVEL ANNIHILATOR™

MODEL 806B SEELEVEL ANNIHILATOR™

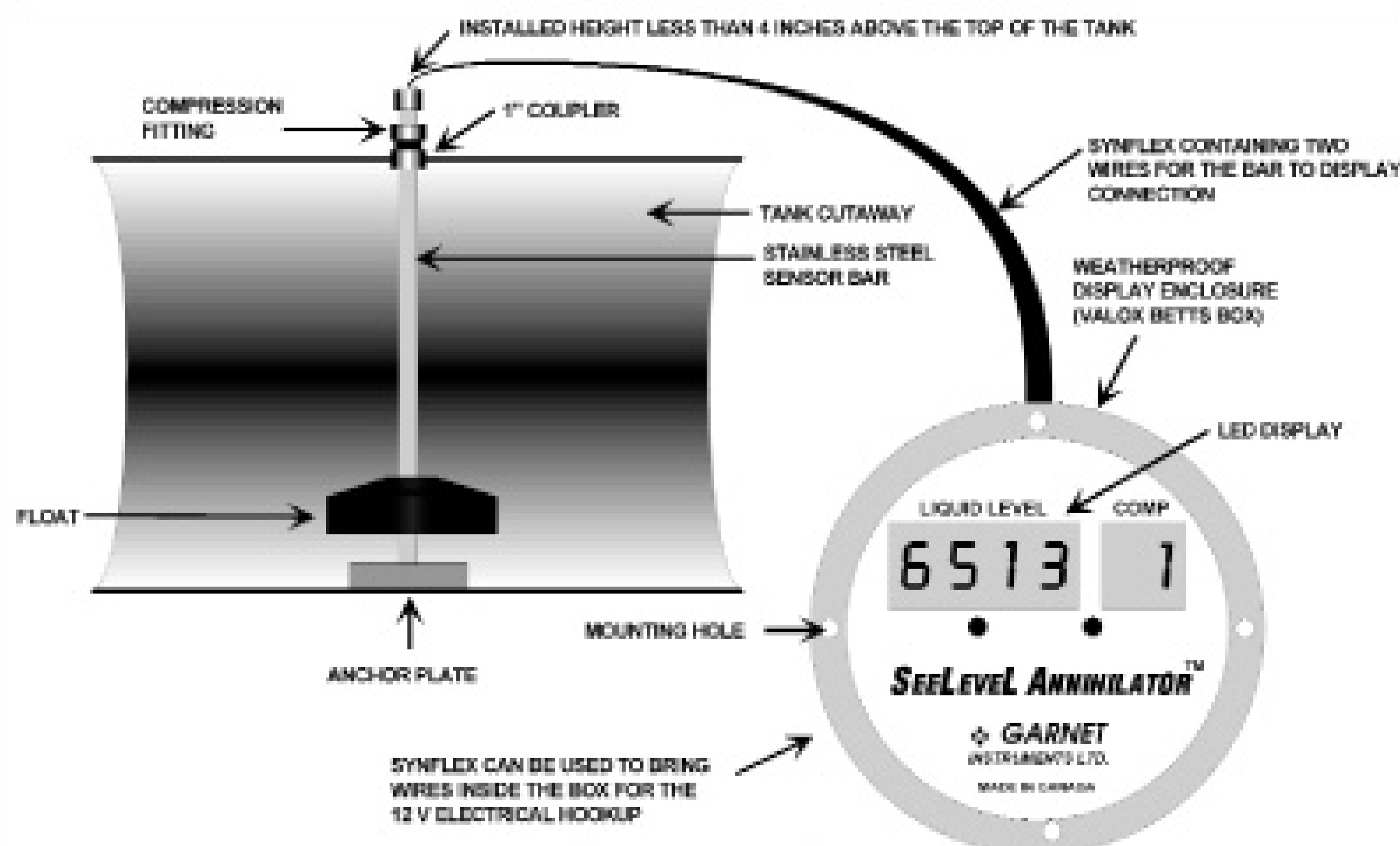

• **Accurate Readings to 1/4"**
Even with vacuum or pressure on the tank. No need to shut down pumping to check tank level.

• **Work Safely**
Can be programmed to control warning devices.

• **Plan Your Route**
Tracking customers tank size allows for improved route planning.

• **Protect Your Pump, Avoid Spills**
See the level of your tank throughout the pumping process.

• **Maximize Efficiency**
Avoid unnecessary trips. Can I get one more load, or should I head for the dump? The guessing game is over.

• **Communicate With Your Customers**
Pumping 1500 gallons from a 1000 gallon tank indicates problems

These are all good reasons to equip your next truck with a SeeLevel model 806B liquid level gauge system. The 806B can be programmed to read liquid levels in up to three compartments with only one display. It can also accept up to three alarm settings for triggering a warning light, sounding an audible alarm, or closing a loading valve; all while the tank is loading.



11200 Greenstone Ave. | Santa Fe Springs, CA 90670
800.699.7557 or 562.944.0404 | fax: 562.944.3636
e-mail: sales@vacpump.com | web: www.vacpump.com

To find out if the 806B can benefit your business, contact your tank manufacturer or call us
Toll Free at 1-800-699-7557

TankTec

Tank Technologies & Supply Co. LLC
 Portable Restroom Service Trucks
 Septic, Grease & Grit Trucks
 Refined Fuel Trucks

888.428.6422

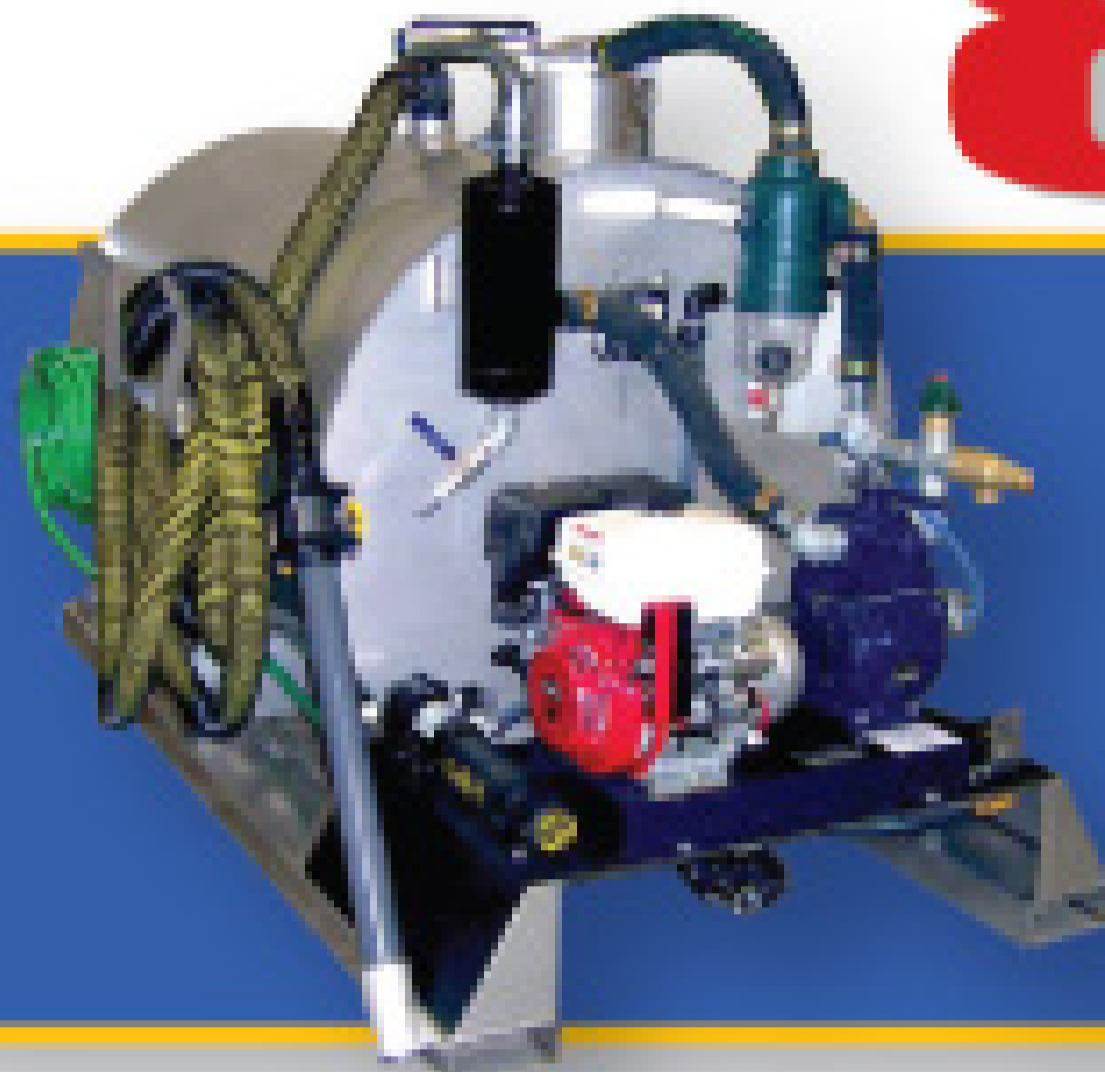

Slide-In Tanks

300 Gallon (200/100 split)
 450 Gallon (300/150 split)
 550 Gallon (380/170 split)

Aluminum Construction
 Honda Gas Motor (5.5 hp or 9 hp)
 Conde 70 CFM or Masport 106 CFM Pump
 Whale Water Pump

Completely Self-Contained and Ready to Work!
Single Compartment and Custom Configurations Available

2009 Ford F550
 1500 Gallon

\$70,500

1100 Waste / 400 Fresh
 Masport HXL4V Pump System
 Burks DC-10 Water Pump



5 Portable Restroom Units in Stock!

Many Trucks IN STOCK! Ready for IMMEDIATE DELIVERY!

2008 International 4400
 3600 Gallon

\$107,000 +FET

10-Speed
 DT466 300 HP/ 860 TQ
 Masport HXL400WV 400 CFM
 Water Cooled Pump System



5 Single Axle Septic/Grease Units in Stock!
7 Tandem Axle Units in Stock from \$74,900

Ask About In Stock Trucks • Call for Lease Payment Details
 Tanks in Stock • Financing and Leasing Options Available • Dual-Use Options
 Customize to Your Needs • PRS 800-2500 Gallon • Vacuum 1000-6000 Gallon



PORTAVAC



ALUMACONK

Tank Technologies & Supply Co. LLC • 888.428.6422 • www.tanktec.biz

Steve Nelson • snelson@tanktec.biz
 Andy Nelson • anelson@tanktec.biz

Local • 763.755.8075 • Fax • 763.757.9788
 10100 Quinn St. NW, Minneapolis, MN 55433

10280 Brecksville Road Brecksville, Ohio 44141



R.A. ROSS N.E., INC.

INDUSTRIAL & TRUCKING BLOWERS • VACUUM PUMPS • SALES, SERVICE, & INSTALLATION



75V

We have a **FULL SERVICE REPAIR SHOP** capable of servicing and repairing a wide variety of different makes and models of blowers and vacuum pumps from all your top manufacturers including
**Tuthill/MD • Drum • Gardner Denver • Cycloblower • Duroflow • Sutorbilt • Roots • Hibon
 Fruitland • Moro • Masport • Wittig • NVE Challenger • Jurop • Battioni • Presvac
 Blackmer • Roper • Ranger • Viking**



SDS12

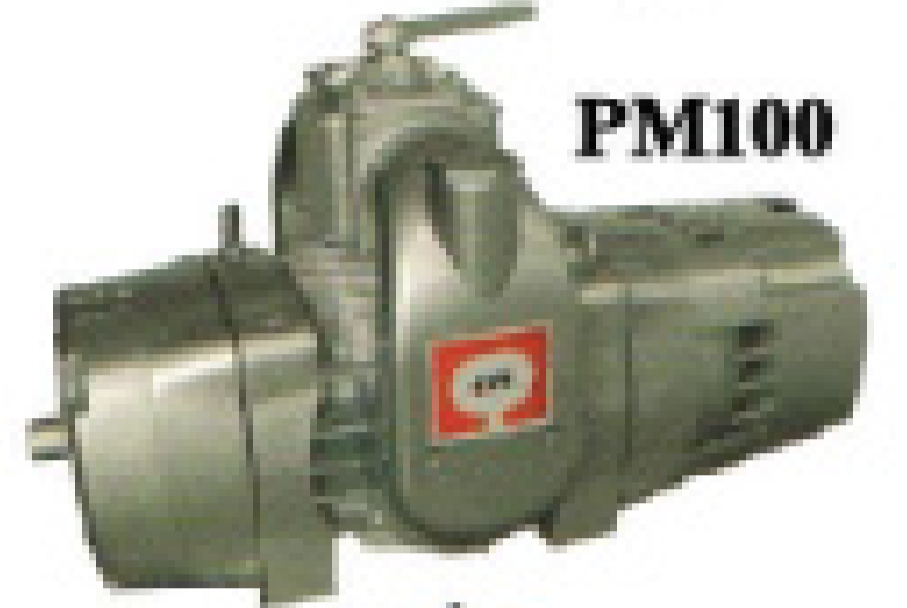

PM100



PVT200



RCF500

FRUITLAND



R260



**Chandler
Equipment, Inc.**



NVE FRUITLAND



Vacuum Pumps • Components • PTO's • Hydraulics • Valves • Manways • Gear Boxes • Mufflers • Silencers • Gauges • Camlocks • Hose

TOLL FREE 1.800.678.4581 PHONE 440.546.1190 FAX 440.546.1188 EMAIL RAROSSNE@RAROSSNE.COM WEBSITE WWW.RAROSSNE.COM



T&T Tools, Inc.

Fax: 800.521.3260
Email: sales@tandttools.com

800.521.6893
www.MightyProbe.com

Call for a FREE Catalog



Call for a FREE Catalog

HOOKS...

- > Several different styles of heat-treated hooks are available
- > Top Poppers are great to open manhole covers
- > The Handy Hooks allow two handed use

PROBES...

- > Insulated, standard, and specialty soil probes
- > Metal shaft sizes: 3/8" round, 3/8" hex, or 7/16" hex
- > Replaceable tips are threaded on and hardened
- > A "slide" allows the handle to pound the shaft into the ground

Dewatering Made Simple.



Sludge Mate™ & Poly-Mate™

The Flo Trend® Sludge Mate® and Poly-Mate® form an economical and simple to use sludge dewatering system.

The Poly-Mate® conditions sludge through the addition of polymer prior to the dewatering process which occurs in the Sludge Mate®.



These units are designed to dewater sludge from a multitude of waste stream sources including: water and wastewater treatment plants, septic tanks, car washes, industrial sumps and lagoons, grease traps,

rendering plants, and food processing plants. The Sludge Mate® and Poly-Mate® are available in a variety of sizes and configurations, and are built to custom specifications.



Flo Trend Systems
707 Lehman St.
Houston, TX 77018

800.762.9893
713.699.9893
Fax: 713.699.8054
sales@flotrend.com

"DON'T BE EMBARRASSED AGAIN!" HOW AWFUL...

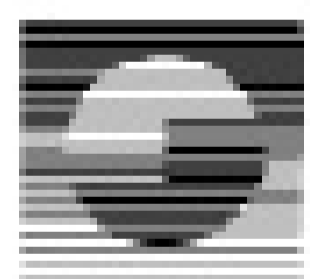

800-622-8768
sweetair.com

SWEET SEPTIC SYSTEMS, INC.
5701 Mother Lode Drive • Placerville, CA 95667
Fax: 530-622-1087

SWEET AIR™ FILTERING DEVICE

HOW WONDERFUL...



435 GALLON VACUUM TANK



- 1/4" Aluminum Construction
- Conde Super 6 Pressure Vac Pump with 5.5 hp Honda Electric Start
- 12 Volt Water Pump
- 300 Waste/135 Fresh
- 25' Hose and Wand
- 2" Sight Eyes in Waste
- Sight Tube on Fresh Water
- Completely Self-Contained
- Ready to Work

OTHER SIZES AVAILABLE

Robinson Septic Service Inc.

125 Rockrimmon Dr., Bellefonte, PA 16823 • t: 814.353.0263 • email: honeydippers@aol.com
1.800.252.3848 • www.robinsonseptic.com

PRIMED for Action

By Ed Wodalski

VACUUM PUMP MANUFACTURERS
OFFER LATEST INNOVATIONS TO
IMPROVE EFFICIENCY AND
PERFORMANCE

A dependable, hardworking vacuum pump is the heart of any efficient septic-cleaning job. But dependability, reparability and recovery are only a few of the important features to consider when shopping for a pump. Should you go liquid or opt for air? Are low profile and low noise among your needs? As the busy summer season begins to wind down, here are a few pumps and technologies from the industry's top manufacturers to consider when you update or expand your fleet.

LIQUID COOLED

The liquid-cooled **HXL400WV vacuum pump** from **Masport Inc.** delivers 400 cfm of air flow with an operating range of 1,000 to 1,275 rpm. Weighing 450 pounds, the pump is capable of achieving 27 Hg intermittently and 25 Hg continuously at sea level. In pressure mode, the pump will produce



HXL400WV vacuum pump from Masport Inc.

30 PSIG intermittently and 20 PSIG continuously. Engineered for faster load times and optimum recovery, a water stabilized cylinder allows higher continuous vacuum and eliminates freeze-ups during the winter months. The mechanically driven oil pump ensures correct oiling with no adjustments needed. The integral four-way valve is designed with a self-adjusting, spring-loaded spool to eliminate leakage through normal wear. Easy to service and rebuild, the pump features a double-end shaft to accommodate clockwise and counter-clockwise rotation drive systems. Each pump also comes with a vacuum relief valve. Forged high-tensile hub shafts with integral bearing jacking screws come standard, along with Viton O-rings and shaft seals. **800/228-4510; www.masportpump.com.**

AIR SERIES

The **PM60A, PM70A and PM80A Air Series** vacuum pumps from **Moro Pumps** are engineered to deliver 233 cfm, 300 cfm and 379 cfm at 29 psi and 1,100 rpm with a 3-inch hose connection. Features include a positive feed oil pump system, cantered rotor, Kevlar vanes, high-quality bearings and open porting manifold design. All the pumps are available for gearbox, hydraulic or factory gear reduction drive. The PM80A has a suggested tank size of 1,500 to 4,000 gallons. **800/383-6304; www.morousaeast.com.**



PM Air Series vacuum pumps from Moro Pumps

Conde SDS from Westmoor Ltd.

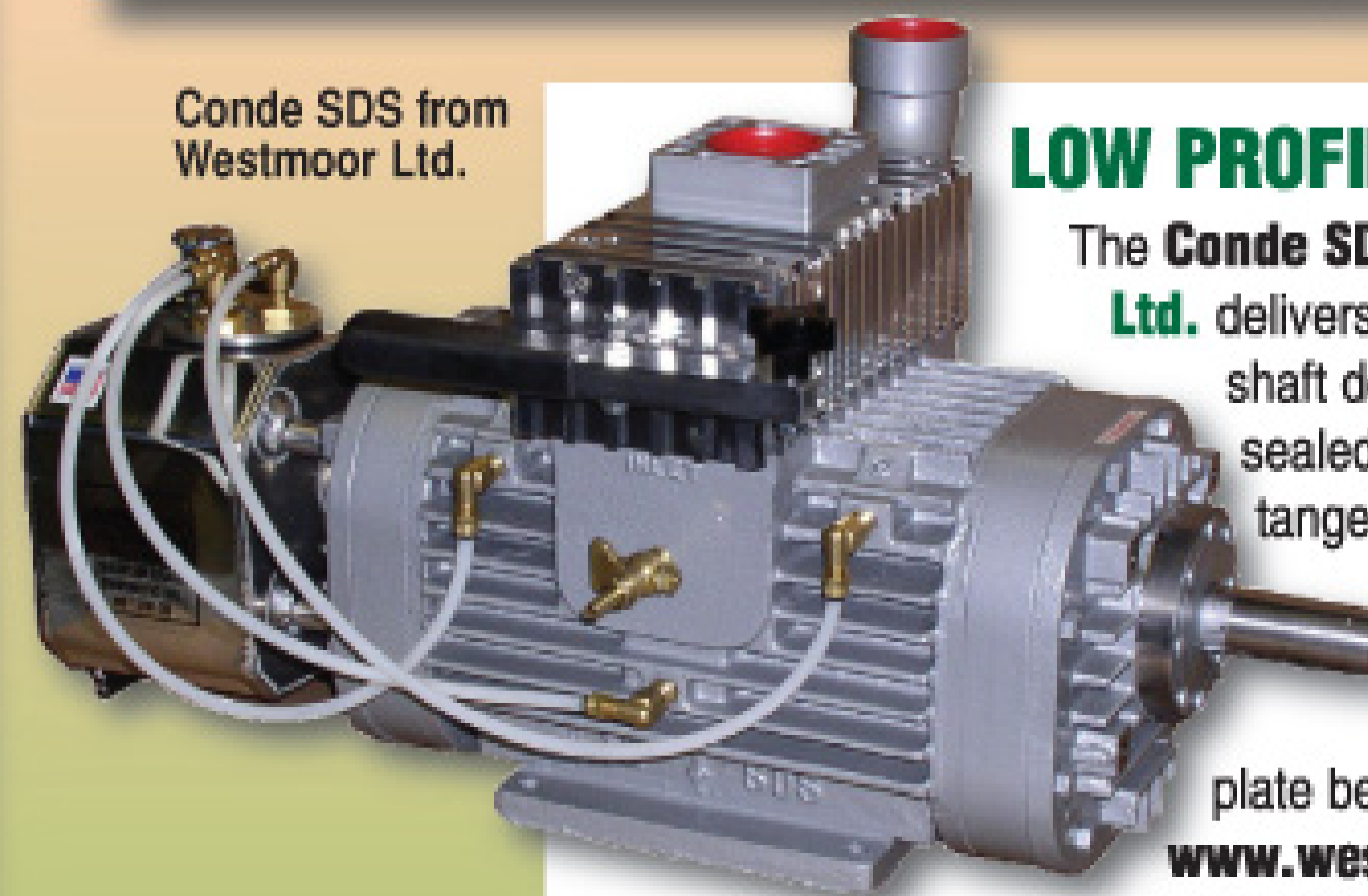

LOW PROFILE

The **Conde SDS** ultra vacuum pump from **Westmoor Ltd.** delivers 230 cfm free air and features double-shaft design, automatic oiling, low profile, sealed bearings, end thrust protection and tangential rotor design for longer vane life. PowerPak gasoline-powered vacuum pump units feature a Briggs & Stratton engine, V-belt drive, diamond-plate belt guard and trim. **800/367-0972; www.westmoorltd.com.**

HEAVY-DUTY APPLICATION

The **250 Series** centrifugal pump from **Dragon Products Ltd.,** Pumps Division, features a stainless steel tungsten/silicone mechanical seal, SKF heavy-duty bearings and brass labyrinth seals. Hydraulic, electric motor or diesel engine pump packages are available, as well as a short frame space-saving version. Dragon also has a full range of agitators from 3 to 25 hp with keyless coupler for easy installation. **866/941-8198; www.modernusa.com.**



250 Series from Dragon Products Ltd.

LOW NOISE

The liquid-cooled **Jurop LC300 Contender** vacuum pump from **Chandler Equipment Inc.** is designed to deliver 300 cfm at 27 inches of continuous vacuum. The low-noise, direct-drive unit hooks to the truck engine and requires no auxiliary cooling system. It has asbestos-free heavy duty vanes, a vacuum-pressure changeover valve and non-return valve integrated in the pump manifold. **800/342-0997; www.chandlerequipment.com.**



Jurop LC300 Contender from Chandler Equipment Inc.

AIR COOLED

The **RCF 500** heavy-duty, air-cooled vane vacuum pump from **Fruitland Tool & Mfg.** is designed for continuous duty and reduced downtime. The 350-cfm pump (1,400 rpm) has eight vanes and close tolerances for optimum performance. A positive displacement oil pump requires no maintenance or adjustments, and delivers precisely the correct amount of oil to each of four locations for minimal oil consumption. Heavy-duty roller bearings and a self-centering rotor allow for quiet, efficient operation. The cooling system incorporates a high-flow fan and shrouded housing that ensures low pump temperatures for all applications and environments. The unit also features easily accessible vane checkpoints and an integral stainless steel filter option that works on both vacuum and pressure to keep debris from entering the pump. Options allow for any mounting or drive configuration. The 450-pound pump provides 320 cfm at 18 inches Hg with pressures to 30 psi. **905/662-6552; www.fruitland-mfg.com.**



RCF 500 from Fruitland Tool & Mfg.

HIGH VACUUM BLOWER

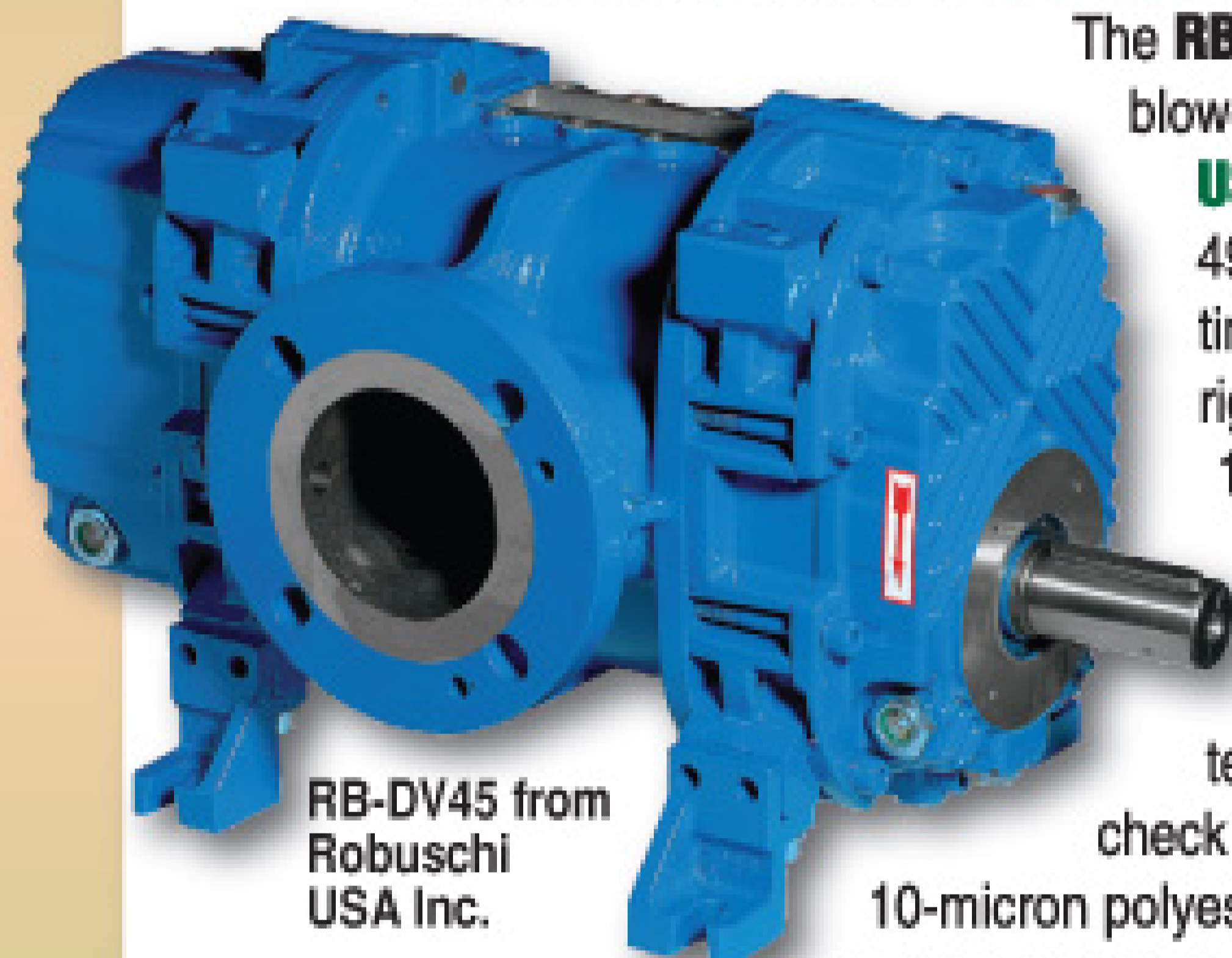

RB-DV45 from Robuschi USA Inc.

The **RB-DV45** high vacuum blower from **Robuschi USA Inc.** delivers up to 494 cfm at 27 Hg continuous vacuum. The right-angle unit has a 1:2 gearbox with flex coupler. Other features include 12-volt gearbox cooling system, remote 4-way and check valves, inlet filter with

10-micron polyester element, exhaust pressure gauge and gearbox temperature gauge, as well as pre- and post-inlet filter vacuum gauges.

704/424-1018; www.robuschiusa.com.

INDUSTRIAL DUTY

U.S.-built, industrial-duty **Challenger Series 607 and 866** rotary vane vacuum pumps from **National Vacuum Equipment** are available with either fan- or liquid-cooled options. Features include built-in crash protection, factory installed temperature probe and easily accessible integral final filter. Delivering 367 and 506 cfm, respectively, the pumps take their name from the European equivalent of 607 and 866 cubic meters of air flow per hour. Other features include mounting bosses on the end plate for gearbox or hydraulic mount; corrosion-resistant, high temperature, clear flow oil lines; an optional diesel flush kit, and remote oil tank with integrated screen. **800/253-5500; www.natvac.com. ■**



Challenger Series from National Vacuum Equipment

LOW MAINTENANCE

The **Wallenstein 753** air-cooled vacuum pump from **Elmira Machine** features close machining for efficient high vacuum. Weighing 340 pounds, the 350-cfm pump with 27 Hg maximum vacuum has extra wide, heavy duty rotor vanes for lower maintenance and less downtime, low rpm operation (1,150 rpm) for quiet operation and easy internal access. **800/801-6663; www.elmiramachine.com.**

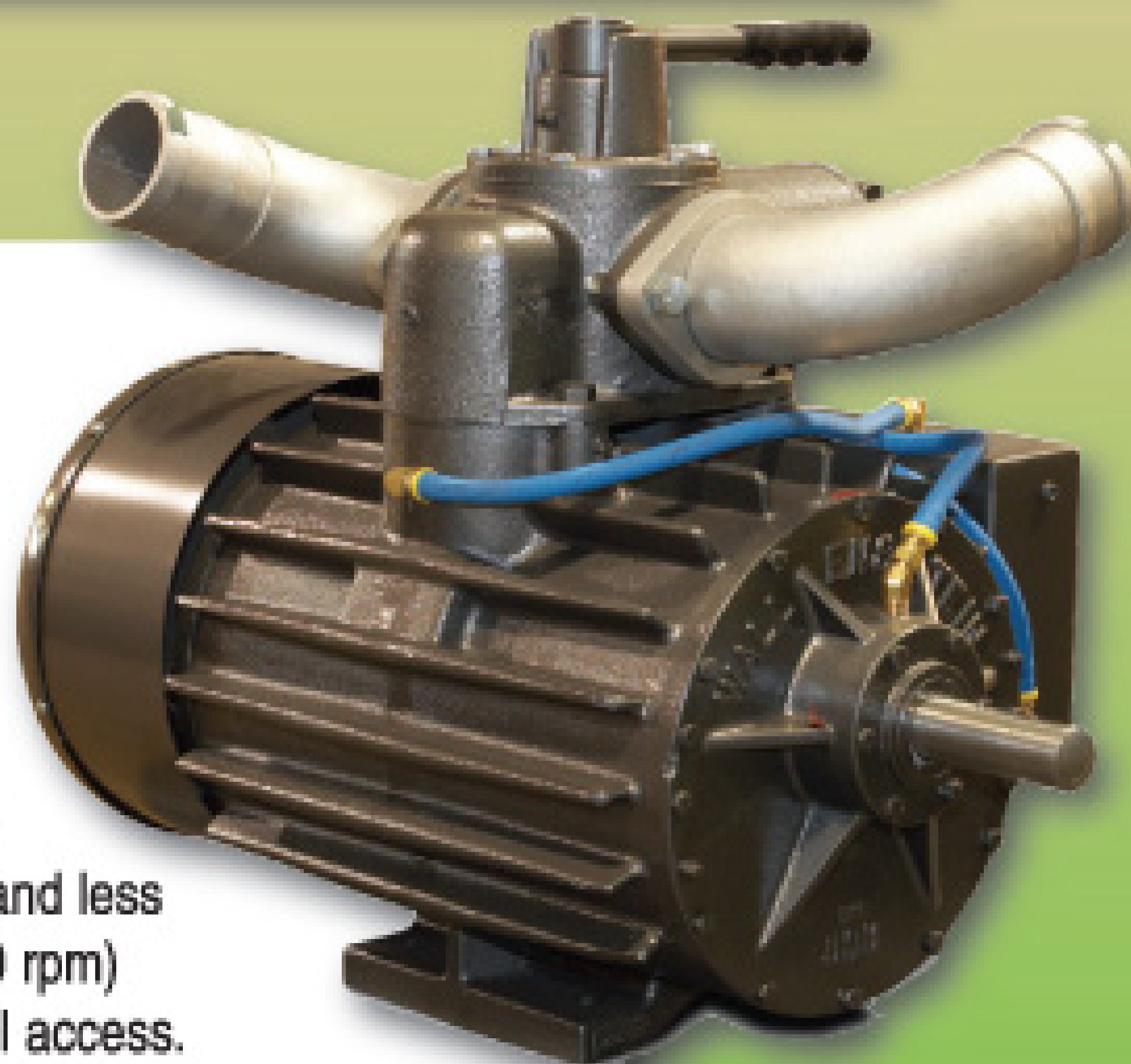

Wallenstein 753 from Elmira Machine

NVE

National Vacuum Equipment
800-253-5500 | www.natvac.com

Introducing
The **607 Challenger™**
Formerly the 367 Challenger™

Same Excellent Performance You Expect! Re-Engineered Externals to Save You Money!



Fan Cooled

Being the **BEST** means never settling!

In that spirit we have reengineered the external portions of the BEST rotary vane vacuum pump on the market meeting the design objectives of lowering costs and adding user friendly features.

Check out the innovations in the only US built industrial duty vacuum pump at www.natvac.com or call for more information.

Challenger™ remains the **BEST** pump built in the **BEST** country!



Liquid Cooled
shown with optional Diesel Flush Kit
and Remote Oil Tank

Cusco...

Working for You To the Last Drop!

What type of equipment are you looking for? Whatever your application, Cusco has the right product for you. For a complete listing of all our products and services visit us at www.wastequip-cusco.com.



Call for a Quote Today! 1-800-490-3541

CUSCO

A WASTEQUIP COMPANY

BEST ENTERPRISES, INC.

It's all about the Stainless



Best Enterprises, Inc.
3513 W. Mt. Springs Rd.
Cabot, AR 72023

1-800-288-2378
Ph: 501-988-1905

www.bestenterprises.net
Fax: 501-988-2880
info@bestenterprises.net

Setting New Standards in Truck Mounted Tanks



TRI STATE TANK

Priced Under
\$50,000

Looks And Runs
Like New!

**2004 International 4300
2000 Gallon Aluminum (500/1500)**

184,000 miles
Complete engine overhaul at 157,000 miles
Thoroughly tested! New hoses!

\$49,950 FOB Kansas City, KS



\$40,000 Less Than A 2009 Model With Same Features

1200 Gallon Septic Pumper
Masport HXL75 pumping system.
2008 Sterling Bullet 305 HP Cummins,
auto trans., hyd. brakes, 84" C.A.

\$69,750 As Low As **\$1243** mo.



BUY IT NOW! \$99
'Guaranteed Credit Approval'

*Per month until January 2010, thereafter regular payments for 60 months with no residual buyout.



Call Us At
888-281-9965
Fax: 913-279-3151

phodes@tristatetank.com

www.tristatetank.com

Michigan Vacuum Trucks

**Custom Built Tanks
to Your Specs!**

P.O. Box 234 Carleton, MI 48117

Specializing in
New Vacuum Trucks.
Used Vacuum Trucks.
Toilet Trailers & Slide in Units.

*We Can Also Mount a Custom Designed
Vacuum Tank on Your Chassis!*

Custom Built Vacuum Trucks to Meet Your Business Needs



All trucks are equipped
with **Masport Pumps &
1/4" Steel Construction**

**Masport
NVE**

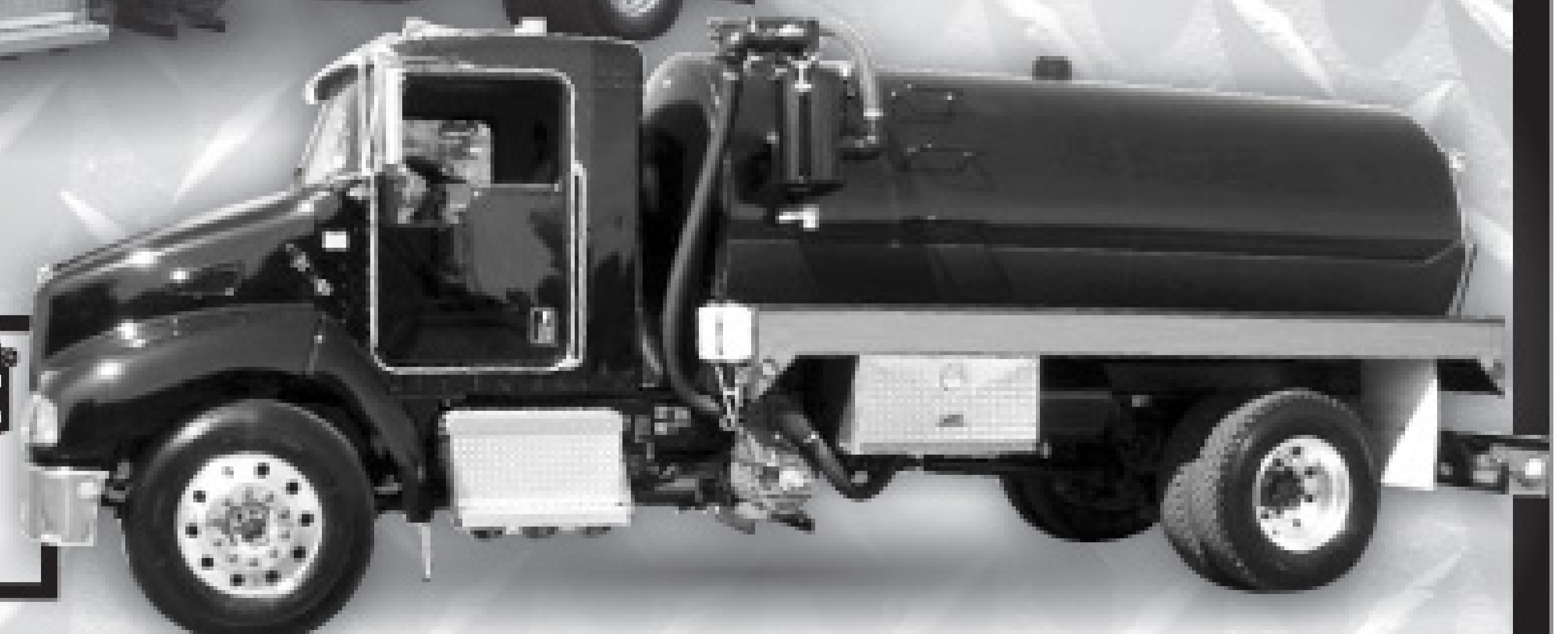

Totaled Your Truck?
Rent a Vacuum Unit
while your truck gets fixed

Call for a FREE quote today!
734.777.0390

*Prices are subject to change.

Building A World of Solutions



Huge Selection of Used & Refurbished Trucks!



Unit #36652 2005 International 7600
 Guzzler DF ACE High Dump, Roots
 1021 DVJ Blower 27", New Paint
READY TO WORK!



Unit #M1334 2009 Sterling 9501
 Guzzler Predator, 3000 Gallon Debris
 Tank, Demag RFL 100 Pump
READY TO WORK!



Unit #06873 Sterling LT9501 Hibon
 8702 27" Blower, Dense Phase
 Offload System, Auto. Transmission
READY TO WORK!

Many More Units Available • Warranties for Most Equipment we Sell and Service

1.800.822.8785 www.fssolutionsgroup.com

Quality People Doing Quality Work

DOT Industrial Vacuum Hoist Units



DOT Industrial Vacuum Units



Portable Restroom Service Units



IN STOCK - 650/350 gal.
Call for Details
Ready for Immediate
Delivery

**SPECIAL
PRICING
\$52,000**

Mini Vac Trailers



**DOT
Code
& Non
Code**

Slide-In Units



THANK YOU to Lester Septic in MI for purchasing this 300 waste/100 fresh Slide-In Unit. More units in stock. Please call for more information.

Marsh
INDUSTRIAL

P.O. Box 1107 - 135 E Mile Road - Kalkaska, MI 49646
p: 231.258.4870 - f: 231.258.2019 - sales@marshind.com

800.952.1537 - WWW.MARSHIND.COM

AMT
A Subsidiary of The Gorman-Rupp Company™

12 VOLT DC HIGH HEAD WASHDOWN PUMP

- 1 HP Washdown Duty Motor for Severe Operating Conditions
- Investment Cast 316 Stainless Steel, Cast Iron or Cast Bronze Construction
- All Models Equipped With High Efficiency Stainless Steel Impeller
- Discharge Port Rotates in 90° Increments
- Four Front Drain Plugs
- Maximum Flow 56 GPM
- Maximum Head 80 Ft. (35 PSI)
- Maximum Temperature 200° F



The AMT 12 Volt DC Washdown Pumps are designed for pumper, septic service, OEM, and marine applications requiring a DC motor. The motor has a one hour duty rating and is furnished with a grade 303 stainless steel shaft. Washdown Duty Pumps are available in a variety of construction and seal materials to meet your specifications. Pull-from-the-rear design for easy servicing without disturbing piping.

Call us toll free at 888-268-7867 or visit our website www.amtpump.com for more information.

American Machine & Tool
A Subsidiary of The Gorman-Rupp Company
400 Spring Street
Royersford, PA 19468



Septic-Scrub™

The First Choice for Pumpers to Restore and Maintain Drainfields

Backed By Science ■ Proven with Experience ■ Many Satisfied Homeowners

Septic-Scrub™ is a superior product for the maintenance and restoration of septic system drainfields. Customers appreciate that it is environmentally safe, contains no organic chemicals and does not produce any toxic by-products. Most importantly, **Septic-Scrub works**. It breaks down sulfide buildup in the biomat and soil to allow for better water absorption.

Learn more about Septic-Scrub at www.arcan.com.

arcan

P.O. Box 31057
Clarksville, TN 37040

For information on increasing sales and providing a valuable service to your customers, call Arcan Enterprises at **888-35ARCAN (352-7226)**





1-800-786-9274

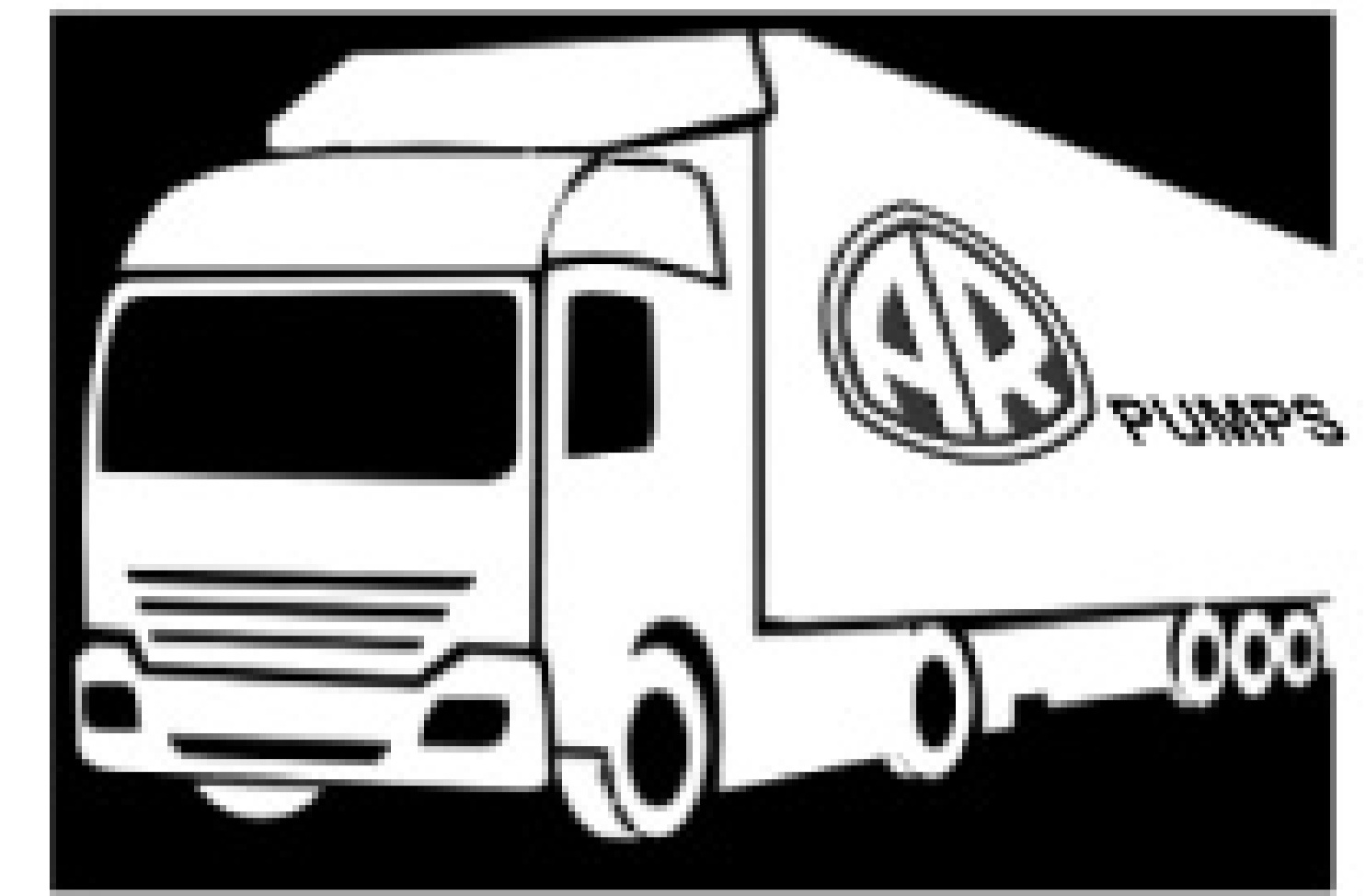

Water Cannon Stocks 1000's of Radial & Triplex Pumps

Vertical Homeowner Pumps - Plumbed Includes Injector & Oil - 7/8" Hollow Shaft



56711	2.2GPM - 2400PSI	RMW22G24-ST-P	\$69
56713	2.2GPM - 2400PSI	RMW22G24-SX-P*	\$96
56724	2.4GPM - 2600PSI	XJW24G26P	\$99
56720	2.0GPM - 2700PSI	XJW20G27P	\$99

*Long Tubes (Not Shown) Reversed Side Position

Axial Pumps - Plumbed Includes Injector, Bolts & Oil - 3/4" Hollow Shaft



42.0162	2.5GPM - 2700PSI	RMV25G27P	\$99
56729	2.5GPM - 2700PSI	SJV25G27-P	\$187

Triplex Pumps - Plumbed Includes Injector, Bolts & Oil - 3/4" Hollow Shaft



56755	3.0GPM - 3000PSI	RSV30G30P	\$159
-------	------------------	-----------	--------------

Triplex Pumps - Bare Includes Bolts & Oil - 1" Hollow Shaft



52703	4.0GPM - 3500PSI	XMV4G35	\$149
52705	4.0GPM - 3700PSI	XMV4G37	\$159
52708	4.0GPM - 4000PSI	SXMV4G40	\$199
52716	4.0GPM - 4000PSI	RKV4G40	\$239
52719	4.5GPM - 4000PSI	RKV45G40	\$299

Shaft Drive Triplex Pumps - Bare Includes Oil - 24 mm Crankshaft



57711	4.0GPM - 3700PSI - 1750RPM	RKA4O37NL	\$249
57716	4.0GPM - 4000PSI - 1750RPM	RKA4O40NL	\$259
57724	3.5GPM - 4000PSI - 1450RPM	RKA35G40NL	\$259
57729	3.43GPM - 4350PSI - 1450RPM	RK13.30NL	\$289

*Shown With Optional Unloader & Rail Kit

Propane Pump Tank Looks Tempting

But posters caution a waste hauler to consider all the problems recycling a 1,000-gallon fuel tank might pose to safe truck operation

This feature in Pumper reports noteworthy conversations that take place in Pumper Discussion, an e-mail based forum for industry professionals sponsored by COLE Publishing. Pumper Discussion provides for the exchange of information and ideas on septic and drainfield installation and maintenance, trucks and equipment, portable sanitation, chemicals and additives, and much more. To find out more about Pumper Discussion, or to subscribe, visit www.pumper.com.

Information and advice in Overheard Online is offered in good faith by industry professionals. However, readers should consult in depth with appropriate industry sources before applying such advice to a specific business situation.

Overheard Online

SHOULD I USE A PROPANE TANK ON MY VAC TRUCK?

Question:

I had an old 1-ton truck with a 500-gallon boiler on the back. For vacuum, I tapped into the vacuum source of the truck's engine. Well, I didn't do this, the previous owner of the business did.

The truck got so old it had to be replaced with the new 2-ton truck that I just bought. I have a new 1,000-gallon 1/4-inch-thick steel propane tank to use for my new vacuum service truck. It's 15 feet long and is one of the common propane tanks you see outside of small commercial businesses.

I have a fear that this tank might collapse under pressure. I will be hooking it to a Conde 70-cfm pump. Should I be bracing the sides of this tank with steel? On another note: The tank has dished ends not flat ends.

Answers:

If it's 1/4-inch steel with rounded tank heads, the suction would most likely not make it collapse if the proper relief valves are installed. Another issue to consider is that you will not have any internal tank baffles and your loads may abruptly shift during travel.

I did the very thing you're talking about. I took a 500-gallon propane tank and shortened it up to install crossways on a truck. It was a big-time fire hazard while working on the tank. Propane tends to soak into the steel, even after a good washing. Just be careful.

A 1,000-gallon tank will carry 8,000 to 8,500 pounds, not including the weight of the tank itself. A 2-ton chassis would be capable of 4,000 plus or minus pounds on the rear axle. With the weight of the tank figured on top of that you'd be two to three times overweight. Not a very safe situation.

You would be wasting a lot of your truck's hauling capacity by using the heavier propane tank. You would be much further ahead to buy a tank specific for the application. Then you could spec the necessary baffles and pressure/vacuum relief valves.

I did the very thing you're talking about. I took a 500-gallon propane tank and shortened it up to install crossways on a truck. It was a big-time fire hazard while working on the tank. Propane tends to soak into the steel, even after a good washing. Just be careful.

I'm not fond of propane. It has always scared me. A friend (welding professional) put a 4-inch fitting/outlet on the end of the tank for me. The first thing we did was hook a hose onto the exhaust of my new International, and hooked the other end onto a pipe on the top of the new propane tank. We let it idle for about 20-30 minutes (until the tank felt warm to touch), and then he cut into it and welded it for me. I guess any of the propane pockets that were still inside were carried out by the exhaust. I had never heard of this before.

If you don't install a baffle on the inside, you will look like a bobblehead doll at the red lights or stop signs, not to mention the dangers posed by liquid movement on curves, etc. You need to have someone in the manufacturing end of tanks give you some advice on this. ■

NEED SOFTWARE?



The Leading QuickBooks® add-on Software for today's Portable Sanitation Business.

- Zero interest and in house financing - 30-Day Money Back Guarantee.
- Software now starting from \$99.95 per month. PC based.
- Interface with QuickBooks® -The Service Program generates your recurring route billing and seamlessly allows you to print the invoices in QuickBooks®
- Palm and Windows PDA Handheld Support w/Remote Sync
- 30 Day No Risk FREE Trial with Weekly Training
- Easily Manage Routes
- Track Pick-Ups & Drop-Offs
- Works with Mapquest® and Mappoint®
- Track Inventory at Multiple Locations
- FREE Updates and Quick Books training

866.480.1879
www.theserviceprogram.com

LOADED PETES OR INTERNATIONALS YOUR CHOICE



2010 Peterbilt 340

\$114,900.00

US Funds – FOB Buffalo, NY
Many options available. Detailed specifications on request.

- Cummins Paccar PX-8 330 Hp
- Fuller 10 speed
- 18,000 front axle, 40,000 pound rear axle
- Air ride, factory air conditioning
- Chrome bumper
- Polished aluminum rims all around
- Bridgestone tires
- Full-locking differential
- Power windows

BOTH TRUCKS HAVE THE FOLLOWING OPTIONS:

- 3600 gallon capacity
- 396 cfm fan-cooled TSI 500 vacuum pump
- 2 baffles
- 20" top man-way, 20" rear man-way
- Heavy-duty primary & secondary shut offs
- Toolbox
- Sight glasses
- Heavy-duty rear bumper
- Full-length hose trays
- 6" discharge, 4" intake
- Complete factory specs available upon request



2010 International 7500

\$106,500.00

US Funds – FOB Buffalo, NY
Many options available. Detailed specifications on request.

- International Maxxforce 10 350 Hp
- Fuller 10-speed transmission
- 18,000 pound front axle, 40,000 lbs rear axle
- Air-ride suspension, factory air-conditioning
- Combination engine/exhaust brake
- Polished aluminum rims all around
- Continental tires
- Thermostatically controlled heated mirrors

2010 INT. Navistar 4300 M7, 2,500 gal.



- Maxxforce 7 230 Hp
- Fuller 6-speed short shift
- 12k front, 21K rear
- Air-ride, air-conditioning
- TSI 500 Vacuum Pump
- **Call for Full Details**

\$76,900 US Funds

WE PAY BORDER CROSSING CHARGES • LEASING? WE CAN REFER YOU TO THE SPECIALISTS • OVER 40 YEARS IN BUSINESS

TRANSWAY
SYSTEMS INC.
PROFESSIONAL VACUUM EQUIPMENT

DELIVERY SERVICE
AVAILABLE

www.transwaysystems.com

Toll-Free 800-263-4508

Tel. (905) 578-1000

Fax (905) 561-9176

314 Lake Ave. North
Hamilton, Ontario L8E 3A2

We pay attention to the details.

- Fabricated to the best industry standards using the highest quality products available
- Custom configurations to your specifications
- VISA, American Express, MasterCard, & Discover
- Fast, same day shipping, low freight rates

**ATLANTA
RUBBER &
HYDRAULICS**

1640 D Sands Place, Marietta, GA 30067
Toll Free: 800.282.6272 • Phone: 770.955.5225
Fax: 770.955.2377 • e-mail: sales@atlantarubber.com



Visit
Atlanta Rubber
at our
NEW
Web Site

www.AtlantaRubber.com

SmithCo
SIDE-DUMP TRAILERS

SIDE DUMP

Call **800-779-8099**
www.sidedump.com

30902 C38
Le Mars, Iowa 51031



*Manure, Slurry, Sludge, Green Waste, Food Residuals, Compost, SmithCo Hauls it All.
Stock Pile, Spread, Stability, Selection, Service...SmithCo*



Commercial



5300 CFM



Industrial



Biosolids



Food Waste Trailers



Grease Trap



Tank Kits

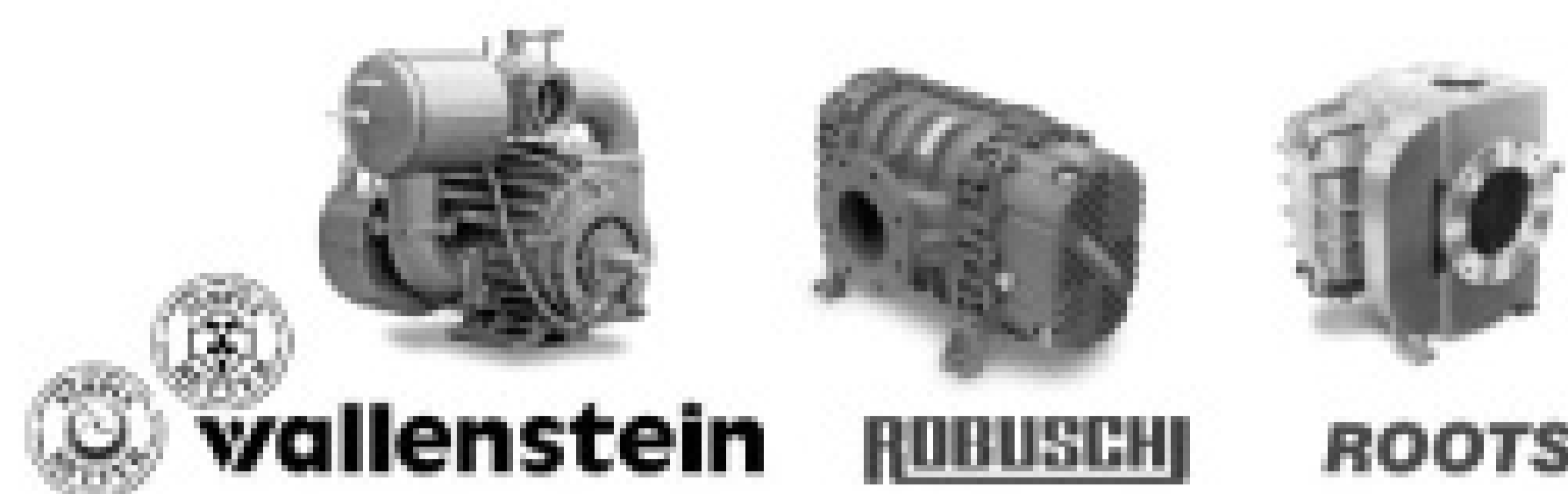

vallenstein ROBUSCH ROOTS

High Air-flow - High Vacuum
Rotary Vane Pumps & Blowers

vacutrux

Specialized Organic Vacuum Equipment

1-800-305-4305

info@vacutrux.com



Septic



Low Profile Underground

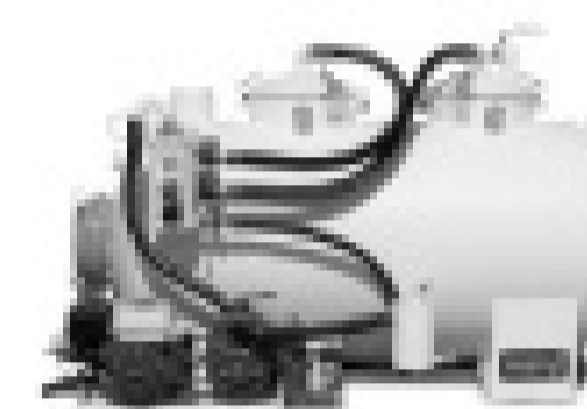

Pickuptrux

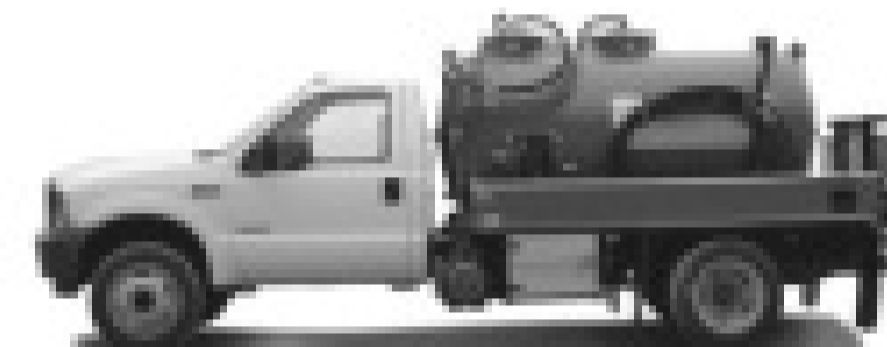

Supertrux



Maxitrux

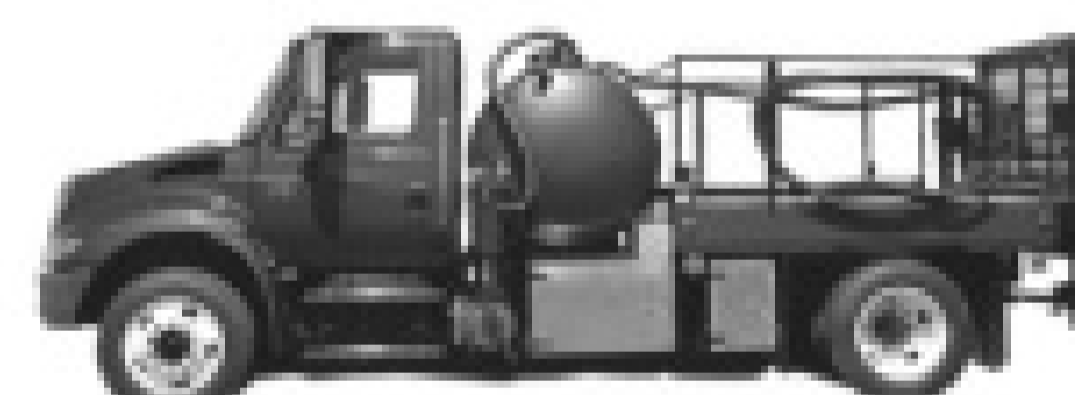

Routetrux



20 Martins LN, Elmira
Ontario, Canada N3B 2A1

DISTRIBUTION OPPORTUNITIES

Best Selling Toilet Transporter!



Industrial Duty Comfort Stations



Self Contained Hand Wash Stations

Florida	Minnesota	California
Steve Bale Ent. Tel: (407) 822-3997 Fax: (407) 822-3998 Apopka FL	Satellite Industries Tel: (800) 328-3332 Fax: (763) 553-1905 Minneapolis MN	Plumas Sanitation Tel: (530) 832-0370 Fax: (530) 832-0373 Portola CA
Alberta	Colorado	Texas
Ted Hoover Tel: (866) 587-7262 Fax: (403) 946-4110 Crossfield AB	Columbia Sanitary Tel: (303) 526-5370 Fax: (303) 526-9686 Golden CO	Woyt Enterprises Tel: (903) 586-6493 Fax: (903) 541-0874 Jacksonville TX

EXPLORER sanitation trailers

Toll Free 1-866-457-5425

fax 519-669-8331

www.mckeetechnologies.com

OEM OPPORTUNITIES



QUALITY RIV BRASS VALVES

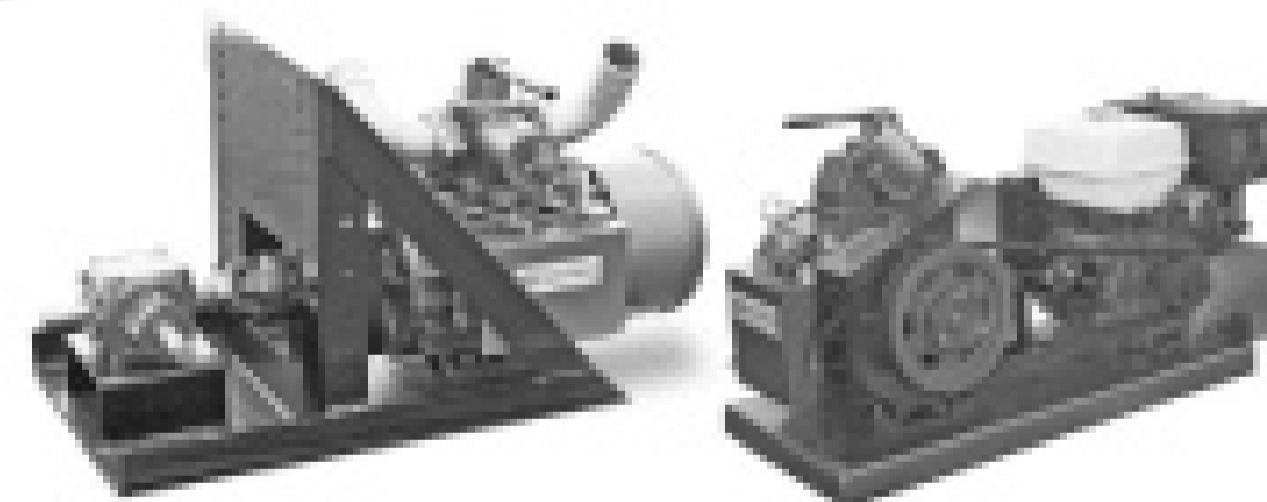

DRIVE PACKAGES



COMPONENTS



vallenstein
vacuum • pumps

Toll free (800) 801-6663 Fax (519) 669-8331



THOUSANDS IN SERVICE

FALL TRUCK MAINTENANCE

PULL 'ER in the GARAGE

AS SUMMER GIVES WAY TO FALL, IT'S TIME TO MAKE SURE YOUR FLEET IS PREPPED TO HANDLE COLD-WEATHER CHALLENGES

By Robert E. Carlson

As the pumping industry moves from the busy summer season to the fall and winter, it's time to park your rigs in the shop and make sure all the mechanical systems are working properly. Just like you want to avoid a breakdown during the hectic summer months, truck failure is not an option in the colder months, either.

So as Mother Nature prepares to hurl a snowball in your direction, let's look at effective ways for you to duck the frozen projectile and keep your trucks safe from common wintertime breakdowns. Follow this step-by-step approach to fall maintenance so you'll have fewer worries running down the road:

LOOKIN' UNDER THE HOOD

Five basic things to check:

1. The battery. How old is it? Are there any signs of corrosion where the cables connect? Does it need to be replaced? Is there anything worse than a dead battery in below-zero weather?

2. The oil. Cold weather will thicken the oil and hinder the process of engine lubrication. You might want to switch to a "thinner" oil based on manufacturer specifications. Don't forget to check the oil in the rear-end differential. Manufacturers usually recommend shifting to a lighter weight gear oil in colder temperatures. One other note: Having the right oil is important, but it won't help much if you're two quarts low.

3. Antifreeze. What's in the radiator now? Make sure the heating and cooling system is ready for the coldest temperatures you're likely to experience.

4. Tune-up and timing. When was the last time you checked the engine timing or got a tune-up? A well-tuned engine will maximize fuel economy.

5. Hoses. Visually inspect all hoses in and around the engine. Some hoses tend to dry out and crack as summer passes. Those hoses will again be tested to get you through the winter.



THE WALK-AROUND

Let's close the hood and check out the rest of the truck:

1. Tires. Tire tread wears rapidly in summer due to the heat and hot stopping. Are the tires going to make it through the winter or are you going to be slip-sliding away? Think about winter tires for better traction, and if you're located where you deal with serious winter weather, what about chains?

2. The body. If you're in a snowy climate, you'll be seeing a lot of salt and chemicals on the roadway. These materials are corrosive to your truck body. As winter progresses, make sure you wash these chemicals off on a regular basis.

3. Heated collars. If your trucks have heated collars, make sure they're operating properly before you actually need them.

4. The brakes. Summer's drifting away. Lots of hot stopping has taken a toll on the braking system. Are the brakes going to make it through the winter without maintenance? Get the brakes checked and make necessary upgrades before the sloppy weather sets in.

THE VACUUM SYSTEM

The truck is ready to go, but what about the vacuum pump and the operating system:

1. Vacuum pump oil. Manufacturers recommend switching to lighter weight oil in winter. This prevents the pump from bogging down. Masport, for example, recommends going from a GST ISO 68 Turbine Oil to GST ISO 46 Turbine Oil in the colder climates. Other pump manufacturers also have their recommendations, so check the operating manual or call the pump manufacturer. Don't assume that because everything is working properly today that it will be fine tomorrow.

REGULAR SEASONAL TRUCK MAINTENANCE, ESPECIALLY PREVENTATIVE MEASURES, IS NOT SOMETHING YOU CAN AFFORD TO SKIP BECAUSE OF A LAGGING ECONOMY. SAVING A BUCK IN THE SHORT TERM MIGHT COST YOU A FORTUNE DOWN THE ROAD.

2. Water in the system. Many of you have had a pump freeze overnight and the following morning you found a cracked vacuum pump. The housing itself wasn't the problem, but the water inside the housing caused the problem. Clearly, a lot of water and liquid is pumped every day. Some of it scoots past the primary and stops at the secondary. That's why it is critically important to drain the secondary every day after pumping. If you wait until the next morning, the water has frozen in the secondary and now any pumping will cause the water to bypass the secondary and head for the pump. The next night, in freezing temperature, the water will turn to ice, expand, and crack the housing. Time for a new pump.

3. Pressure and vacuum relief valves. If these valves freeze, due to water or other liquids, and they don't function properly, you run the risk of collapsing the tank or with pressure, exploding the tank. Neither is good for business. These valves can be tested in minutes before starting out every day and even on every job.

4. Hoses. Going into winter, double check the condition of all hoses. Not just the suction hoses, but look at hoses that connect the primary to the secondary, and the secondary to the pump. Make sure water is not trapped in the hoses overnight. There's nothing like starting the vacuum system on a freezing day and there is no suction because ice has shut the system down.

5. Visual check. Take a look inside the primary. Is it beginning to rot away? Is it good for another winter? If there's a manway on the tank, open it up, grab a flashlight, and inspect the interior. Rust? Other types of corrosion?

A FINAL WORD ON SEASONAL MAINTENANCE

Regular seasonal truck maintenance, especially preventative measures, is not something you can afford to skip because of a lagging economy. Saving a buck in the short term might cost you a fortune down the road. ■

Industry's 1st Collapsible Mover

Move portable restrooms in a fraction of the time compared to using the leading competitor solution. Collapse, store, & go. No transportation hassles. What's your time worth?

- ✓ Fits on a truck
- ✓ Fits in a john
- ✓ Durable & sturdy
- ✓ Lightweight
- ✓ Easy to use
- ✓ Time Saver



mini
METRO
mover.com

call for a quote
920.493.2987

www.miniMETROMover.com

©2009 Allied Forward Motion LLC
mini METRO mover patent pending

SHOWER TRAILERS DISASTER RELIEF - ARE YOU PREPARED?



Call Now
To Be Included As A
Preferred Supplier

Standard Options

- Includes LPG Heat On Demand Water Heaters
- Private Showers
- Changing Area with Optional Bench
- Water Resistant Interior
- Steel Studs & Roof rafters
- Exhaust fans

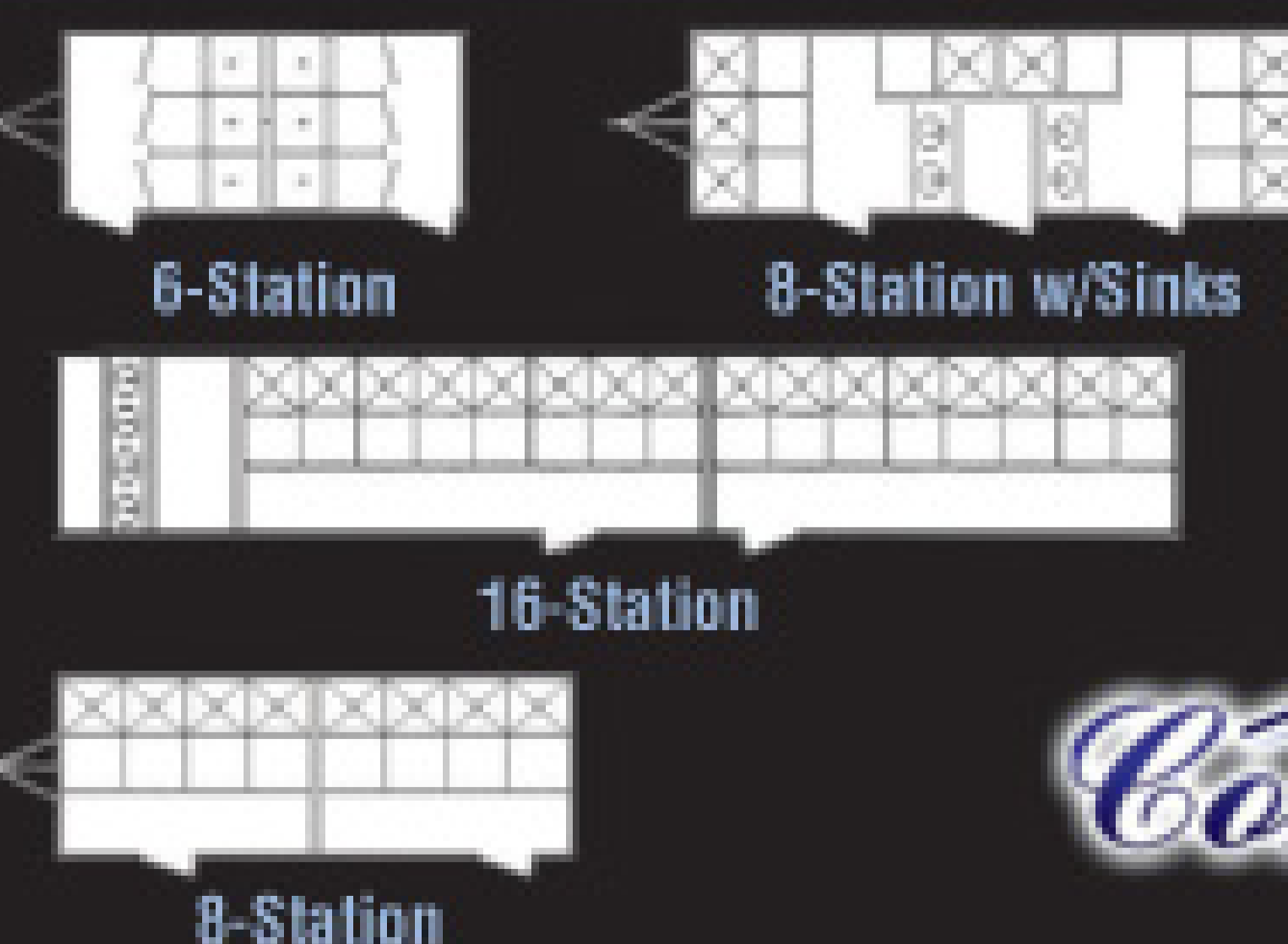

Comforts of Home
Services, Inc.

info@cohsi.com • 877.382.2935 • www.cohsi.com

Decals • Signs • Labels & More!



We Specialize in Waste Management Labeling Solutions

- Service Records
- Lock Out Tags
- NCR Records
- Warning Decals
- Logo Signs
- Gender Signs
- Service Call Forms
- Service Tags

All Printing & Signs Can be Customized at No Additional Charge

1-800-875-7859 www.AnchorGraphics.com
Fax: 972-422-4311 Info@anchorgraphics.com



Lely Waste Solutions, LLC

Temple, TX | 800 367 5359

Thanks To
A-1 WASTE WATER SERVICE



80 BBL Vacuum Tank
Thanks To **RANDY WISE**



Temple, TX
800 367 5359
Fax 254 938 7204

www.lelywaste.com

Bruce Curry
bcurry@lelywaste.com
Earl Ballard
eballard@lelywaste.com

You've Seen it at the Show
You've Heard of its performance
See what it can do for you.

POWER BOOSTER
Patented Technology for Pumping

Discover how over **30 years** industry experience and proven technology will increase your vacuum truck performance. By providing limitless vertical lift and distance capability, this unit will shorten project time.

Solid engineering coupled with rugged, lightweight construction make the **Power Booster™** the ultimate pumping solution. Unsurpassed execution in highly viscous applications.

PL Pressure
Lift Corp

972.355.0550

Call for a **FREE Demo DVD**



TOP LINE

Top Line Accessories

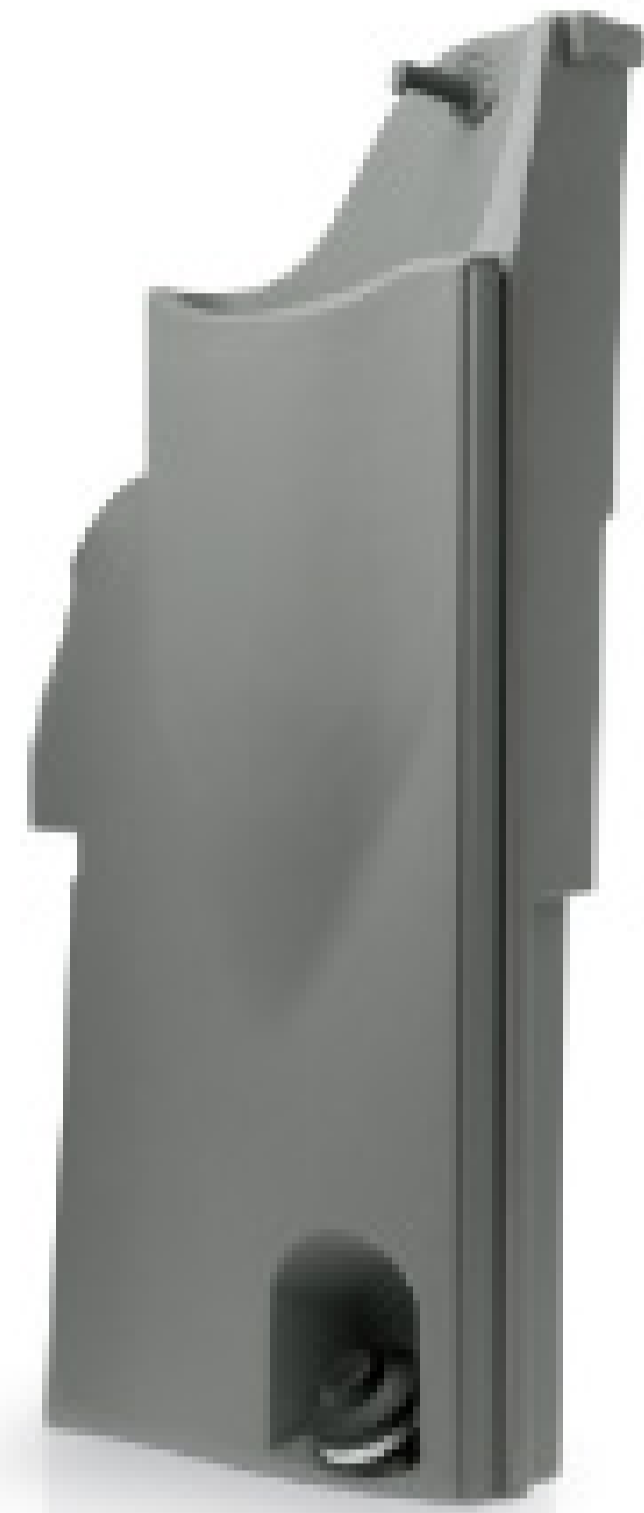

Hand Wash



Fresh Water Flush



LEOMES

Walls do not have Armal logo.

REGULAR PRICE
~~\$ 599.00~~
DISCOUNT PRICE
\$ 339.00
OR LESS.

Armal

www.armal.biz

Armal Inc. 122 Hudson Industrial Drive, Griffin, GA 30224 - USA
Phone 770 491 6410 - Fax 770 491 9458 - Toll Free 866 873 7796
armal-inc@armal.biz

chempace[®] corporation

www.chempace.com

Serving the Industry for Over 40 Years!

One-Stop-Solutions For PORTABLE SANITATIONS & SEPTIC & GREASE HAULERS!

**BUYING DIRECT
ALWAYS EQUALS
COST SAVINGS**

**CALL FOR
MONTHLY
SPECIALS!**



**SEPTIC TANK
ADDITIVES \$6**
(Per Pkg)



**NEW
PACKAGING
OPTION**

**LONG LASTING
PINK CUBE**
\$40 EA (4 Per Case)

Designed to last in hard
to service lifelines/grease traps

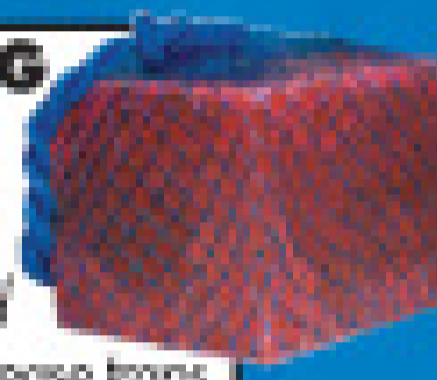

Big Shot[®]

Con2 & Con2 Plus

- Super Strength Concentrate
- Non-Formaldehyde
- Ideal for Summer Use

**NEW
FEATURES
ON 3 GREAT
PRODUCTS!**

**NEW
FORMULA!**

**ENHANCED
FRAGRANCE!**

**STRONGER
DYE**

Ultra PowrPak XL

- Convenient Carry Pail
- Effervescence



SEWER FOAM

\$59.75 (Per Pail)
Reduce solids & hydrogen
sulfide odors • Economical
approach to sewer maintenance

BUY DIRECT CALL 800-423-5350

Industry NEWS

Vanair Acquires Air N Arc

Vanair Mfg. has acquired Air N Arc Inc. of Hiawatha, Kan., and will relocate operations to its manufacturing facility in Michigan City, Ind. Vanair will maintain the current Air N Arc product line and dealer network. It also has retained president Vince Eck, sales manager Dean Strathman and production manager Donnie Stone. Vanair manufactures vehicle-mounted air compressors, generators, multi-drive systems and power take-off technology.

Satellite Industries Enhances Web Site

Satellite Industries has enhanced its Web site, www.satelliteindustries.com, to include Global restrooms and accessories obtained with the acquisition of Hampel Corp. The site also includes product promotions, expanded industry news and a World Class Customer Service program that tracks customer satisfaction with order entry, order fulfillment, delivery and overall product quality.

Crest Precast Launches New Web Site

Crest Precast has launched a new Web site, www.crestprecastconcrete.com, featuring complete product drawings for septic tanks and grease interceptors.

Ohio Approves Puraflo Residential Wastewater System

The Ohio Department of Health and the state's Sewage Treatment Technical Advisory Committee have approved the Bord na Mona Puraflo Peat Fiber Biofilter wastewater treatment for 2-foot soil depth credit installations. ■

ABERNETHY 1.800.545.0324

abernethyinc@charterinternet.com

WELDING & REPAIR INC. Financing Available



2009 International 4400E Series, 260 hp diesel DT 466 engine, 6-spd. trans. and world class auto, air brakes, 33,000 GVW, A/C, 2500 gal. tank, Masport HXL400 pump. Also, 2500 and 3500 gal. tanks. **READY FOR DELIVERY.**

• Ford • GM • International

2009 INTERNATIONAL 4400

2500 gal. tank, (1) 6-spd. trans. & (1) auto trans.

2-2009 KENWORTH T300

2500 gal. tank, auto trans., 260 hp

NEW PORTABLE TOILET UNITS:

2008 5500 CHEVROLET 1000 gal. 700 waste / 300 fresh, 2 Wheel Drive & 4 Wheel Drive available

3-2009 INTERNATIONAL 4300

1500 gal. portable toilet service units, auto trans.

2009 KENWORTH

1500 gal. portable toilet service unit, auto trans.

WE WILL CUSTOM BUILD YOUR TANK UP TO 5000 GALLONS!

600-1500 Gallon Portable Toilet Trucks:
Our Truck or Yours

SEVERAL GOOD, OLDER TRUCKS TO CHOOSE FROM:

- 2006 International - 2500 gal. tank, 65,000 miles
- 1998 Volvo - 4000 gal. tank
- 1995 Chevrolet - 1800 gal. tank, gas, under CDL
- 1995 International - 2500 gal. tank

PORTABLE TOILET UNITS:

- 2007 Chevrolet 5500 - Call for prices.
- 1999 International 4700 - 1100/400 gal. tank, good condition
- 1999 Sterling - 1500 gal.
- 1997 Ford F450 - 800 gal. tank
- 1994 UD - 1200 gal. tank

**MANY OTHER UNITS IN STOCK!
CALL FOR UPDATE**

TRUCK REFURBISHING AVAILABLE

NVE Wittig Masport

COMPLETE PARTS AND IN-HOUSE SERVICE

www.abernethywelding.com

Coagulants and Flocculants for Septic, Grease, Municipalities and Industry

**Celebrating
33 YEARS
in business**

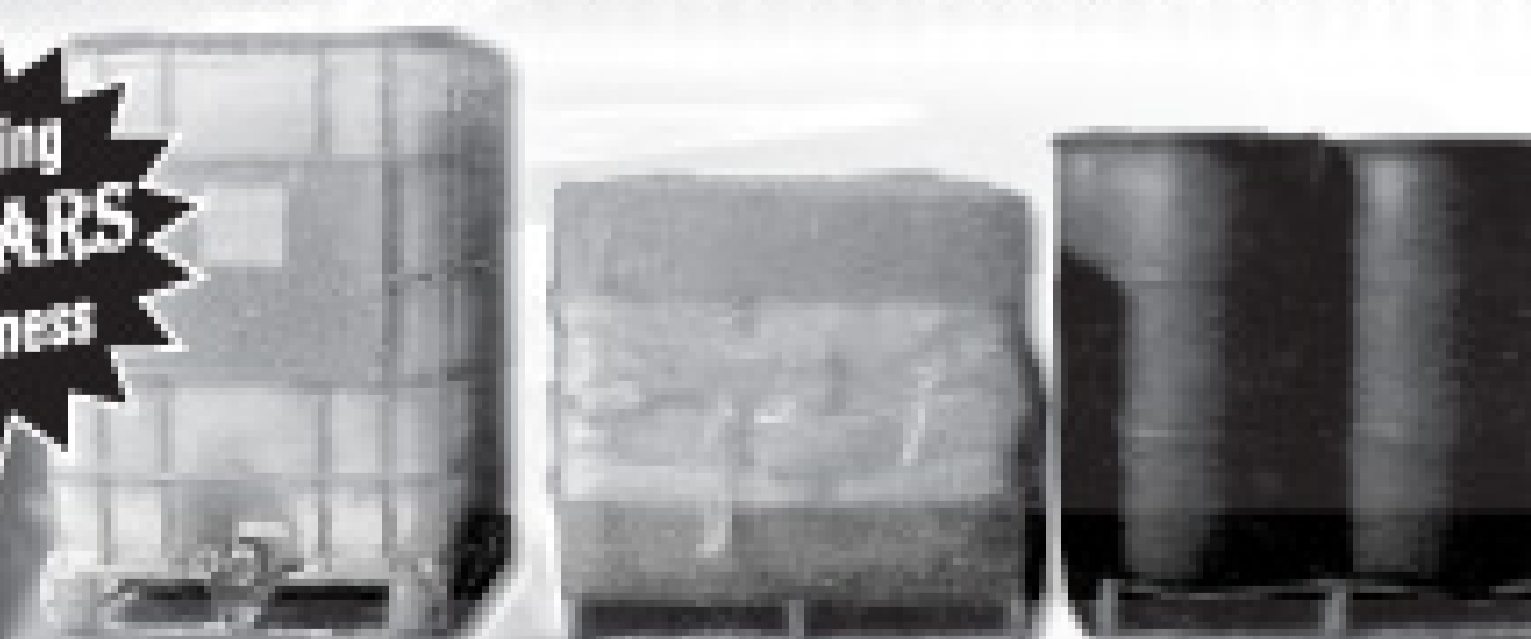

Save Money • Save Time • Save Polymer

- Dewatering polymers for all dewatering equipment
- All forms: Dry and Emulsion
- Variety of packaging sizes to meet customer needs
- Both East & West coast shipping points
- Expert technical staff
- Specific solutions for our customers

Call Toll-free:
877.771.6041

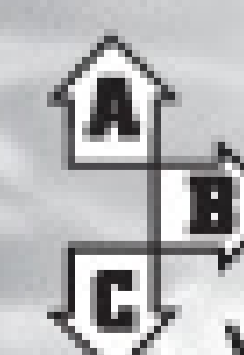

Aqua Ben Corporation

1390 N. Manzanita St. • Orange, CA 92867

www.aquaben.com • sales@aquaben.com

GUZZLER®



A True WORKHORSE

The Guzzler CL has been referred to by contractors, operators and mechanics as the workhorse of the industry. Its easy to operate, easy to maintain and built to last — all for an affordable, no-nonsense price. Tough times call for a tough, reliable truck you can count on. Put a workhorse to work for you — the Guzzler CL.

Call today for a demonstration or more information
815.672.3171 • www.guzzler.com

GUZZLER
Subsidiary of Federal Signal Corporation

No COMPROMISE



Don't accept a substitute for quality. The Burks DC-10 is still the most popular, high volume washdown pump available.

With flow rates to 20 gpm and pressure to 40 psig, the Burks DC-10 is the pump of choice for filling and washing your portables.

Contact your local tank manufacturer for more info, or call us toll-free at:

800-699-7557

**ARMSTRONG
EQUIPMENT
INC.**

11200 Greenstone Ave. • Santa Fe Springs, CA 90670
562-944-0404 • Fax: 562-944-3636

www.vacpump.com

LOW PROFILE Portable Holding Tank

100 • 210 • 300
Gallon Sizes

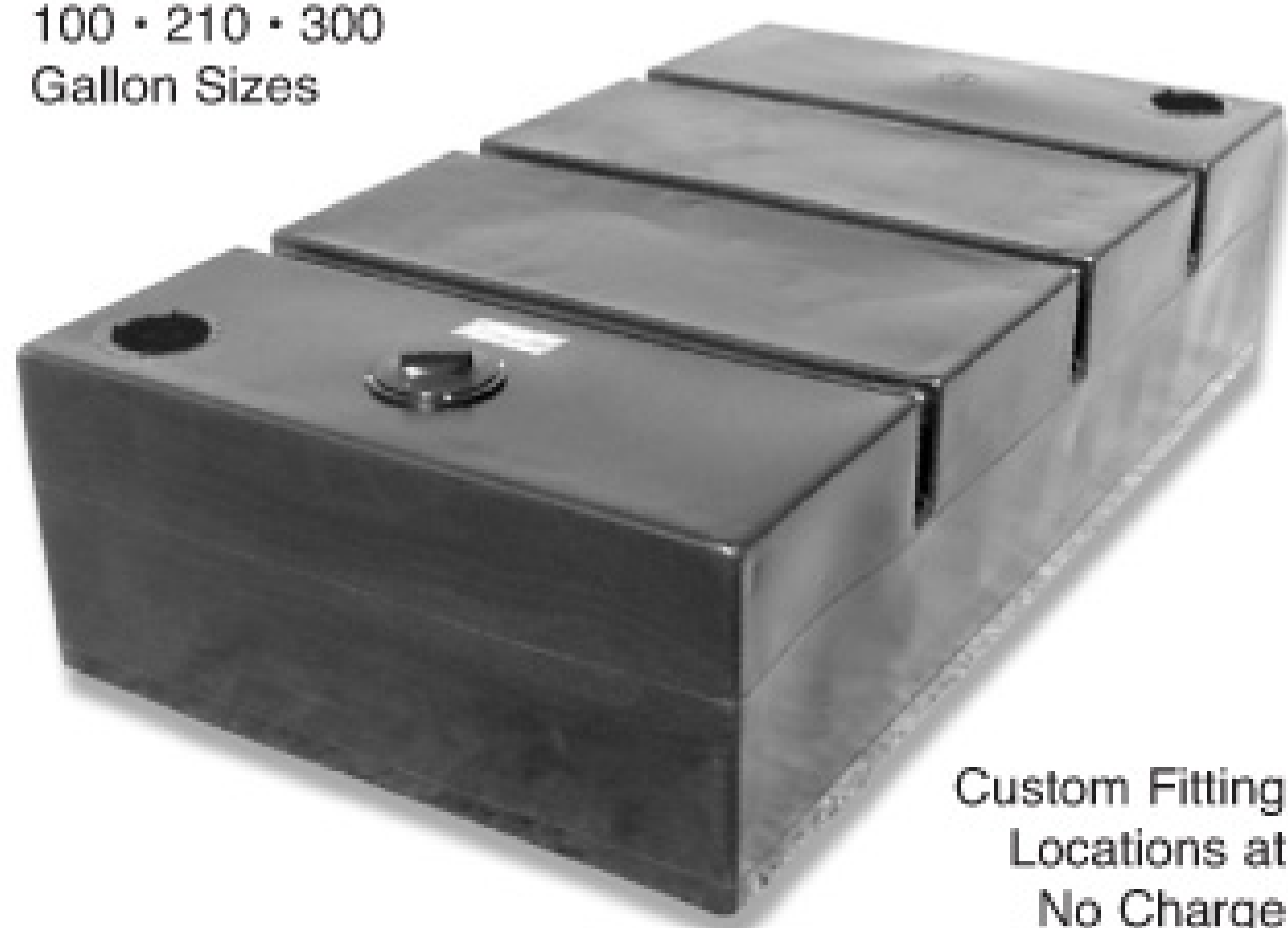

Custom Fitting
Locations at
No Charge

Septic and Cistern Tanks



Mega Holding Tank
1250 Gallon Size

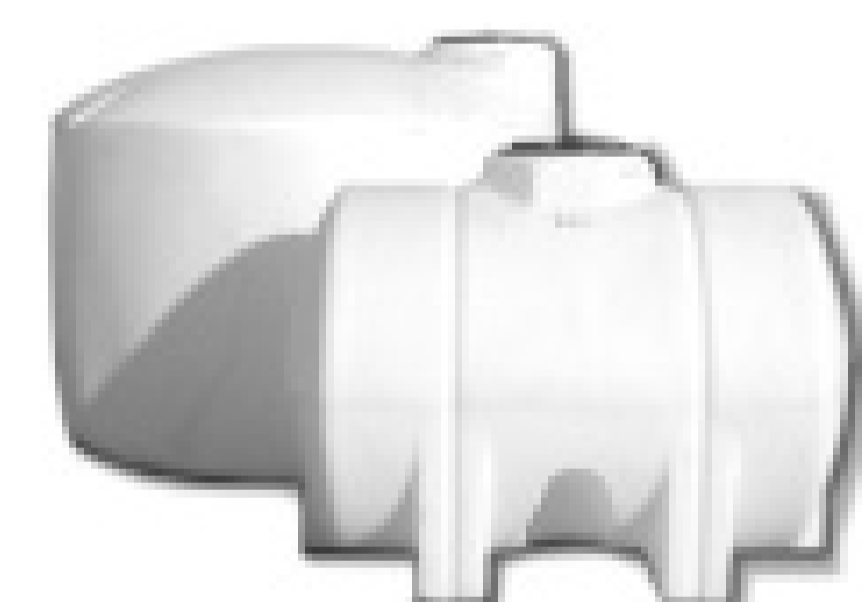

Bulk Storage and Transport Tanks



Ball Valves and
Cam Lock Couplers

On-Site Water System

OSW PLUS —

- Tough 65 gal. Tank
- Removable cover for easy cleaning
- 115V On-Demand Pump 3.5 gpm 45 psi
- Low water shut-off
- GFCI Protected
- Filter
- Ships UPS

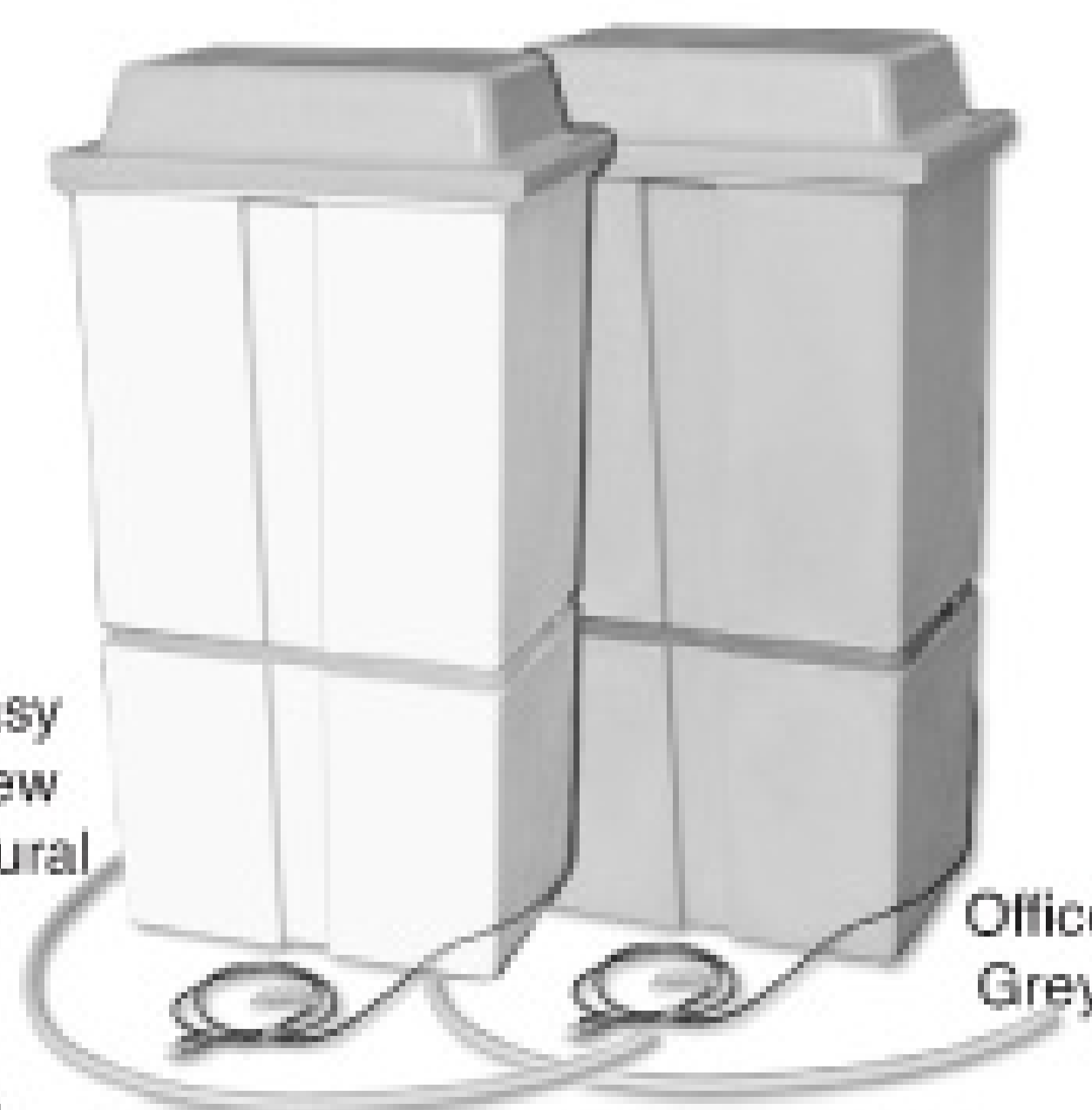

Easy View
Natural

Office
Grey

OSW DELUXE —

- Add external fill connection w/float valve

NORWESCO

Distributor Since 1987

Nationwide Shipping Points

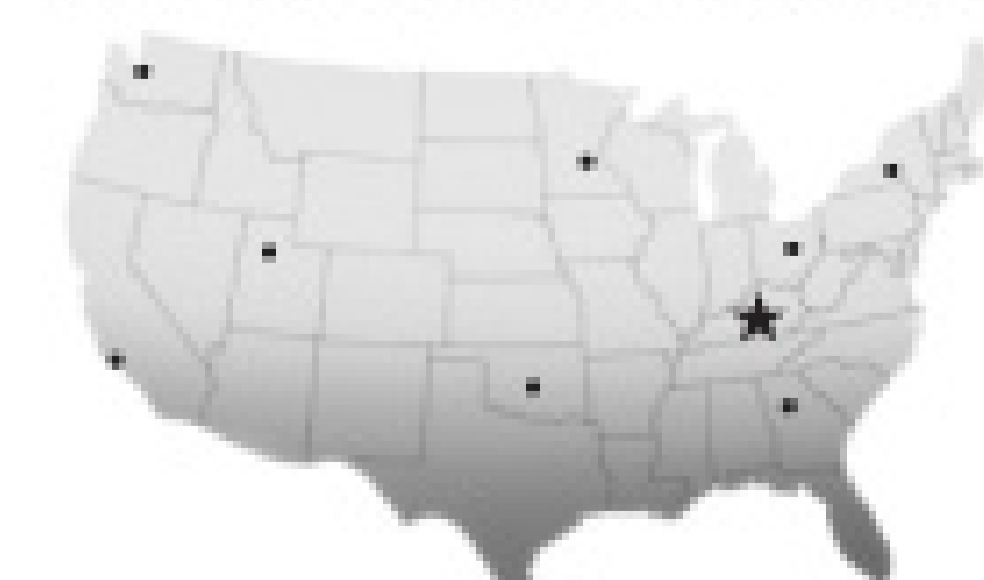

KentuckyTank

Plastic Tanks and Accessories

1-888-459-8265

www.kentuckytank.com

TRANSPORT TRUCK SALES, INC.

Ask for Scott or Frank – 888-395-7551
After hours call Scott at 816-590-4076



What Does It Take To Be A "Qualified Chassis"?

- ✓ Pass our 12 point checklist. (We send this out with every quote!)
- ✓ Pass a D.O.T. certified inspection!
- ✓ Pass the warranty inspection!

What Does All This Do For You?

- ✓ Nationwide drive train warranty for 2 years/ 200K miles! (restrictions apply)
- ✓ A tough truck that is ready to work as hard as you do!

YOUR TRADES ARE WELCOME!

**Searching For A Brand New Chassis?
We Have Them In Stock!**



(3) 2005 International 4300's, DT-466E 220HP, Autos, Non CDL, AC, Progress 2000 gallon aluminum portable toilet tanks, HXL -75 Masport vac pumps, two tool boxes, fresh water pumps, toilet racks, excellent condition, ready to work.
Call For Pricing!

2000 Freightliner FL-70, ISC 225HP, auto, AC, cruise, NON CDL, new 1850 gallon steel vac tank, new PN-84 Juroop pump.

Call For Pricing!
2-YEAR 100,000 MILE DRIVE TRAIN WARRANTY



2000 Freightliner FLD120 Severe Duty, 12.7L Detroit 430 HP, 13 spd, jakes, double framed, 18# fronts, 46# rears, new 3360 gallon steel vac tank, new liquid cooled HXL-400 Masport vac pump.
Call For Pricing!

2-YEAR 200,000 MILE DRIVE TRAIN WARRANTY

2002 Sterling Acterra, Cat 230 HP, 6 spd, AC, cruise, 33# GVW, new 2300 gallon steel vac tank, new PN-84 Juroop pump.

Call For Pricing!
2-YEAR 100,000 MILE DRIVE TRAIN WARRANTY



2002 Freightliner FL-112, CAT C-10 350 HP, 9 spd, jakes, 14,600# fronts, AC, double framed, new 3600 gallon alum. vac tank, new Masport HXL-400 vac pump.
Call For Pricing!

2-YEAR 200,000 MILE DRIVE TRAIN WARRANTY

2001 Mack CH613, E-7 380 HP, 10 spd, jakes, AC, double framed, LOW MILES, new 3360 gallon steel vac tank, new liquid cooled HXL-400 Masport vac pump.

Call For Pricing!
2-YEAR 200,000 MILE DRIVE TRAIN WARRANTY

Delivery Available Anywhere in the Lower 48!!

The Future of Private Waste Processing

As Orlando's Select Processing prepares to host the 2009 NAWT Waste Treatment Symposium, company president Steve Macchio talks about treating waste for pumpers

Many pumping contractors build wastewater treatment plants to process the waste they haul, but Steve Macchio of Lindenhurst, N.Y., is in the wastewater treatment business. His facilities, one each in Lindenhurst, Orlando, Fla., and Elkhart, Ind., treat restaurant grease trap waste, septage, sewage sludges and portable restroom waste. Some also process non-hazardous industrial wastewater.

Macchio says he's been able to modify each property, making the treatment plants as operator-friendly as possible. Lindenhurst was a precious metal recovery facility, Elkhart treated pharmaceutical wastes, and Orlando was a privately owned plant that land-applied lime-stabilized septage.

The National Association of Wastewater Transporters chose Macchio's Select Processing facility in Orlando as part of its Waste Treatment Symposium on Oct. 9-10. Macchio talked to *Pumper* about the benefits and challenges of operating a privately owned wastewater treatment business and how it differs from what most pumpers do.



"PUMPERS BUILDING TREATMENT PLANTS TO SERVICE WHAT THEY HAUL SHOULD STICK WITH SEPTAGE AND UNREGULATED WASTE. THOSE LOOKING TO ENTER THE TREATMENT BUSINESS SHOULD CONSIDER PROCESSING THE MORE COMPLICATED WASTE STREAMS, BUT THEY REQUIRE ADDITIONAL FOCUS AND ENERGY BECAUSE OF THE DIFFERENT TREATMENTS AND REGULATIONS."

Steve Macchio

challenges is controlling odors to keep the neighbors happy.

Pumper: What type of filtration do you use?

Macchio: All of our tanks are above ground, but most are enclosed. The complete Lindenhurst operation is indoors. The plants have odor control devices such as chemical scrubbers that cleanse the air before it's released into the atmosphere.

Pumper: Who runs your treatment plants?

Macchio: Each facility has a manager who reports to me. Depending on the state, some need a treatment plant operator license; others, a licensed operator has to work a certain number of hours to cover the facility's license requirement. My managers have experience in septage hauling and understand trucks. I taught them how to run the plants, but it takes a year or two before they are effective.

Pumper: What is your opinion of pumping companies joining forces to operate treatment plants?

Macchio: Pumpers joining with other pumpers or associations have potential, but it's based on who wants to be involved and can they work together harmoniously? The disadvantages are that the operation most likely would not generate enough profit to benefit all the shareholders, and multiple partners could sometimes prolong the decision-making process. The benefits are that partners reduce the capital burden and bring diverse expertise to the table.

Pumper: What challenges do you see on the horizon for the private treatment processing industry?

Macchio: Siting a plant is one of the most difficult, followed by the approval process and having the capital. That won't change. I learned that owning a waste hauling company could hurt your treatment plant business because other haulers fear you will steal their customers by offering lower prices. That's why I don't own one.

On the other hand, municipal facilities closing their doors to haulers would enhance and support private industry. It could be an opportunity to build or expand existing plants.

Pumper: Because municipal treatment plants don't work for a profit, how do privately owned facilities combat the lower prices?

Macchio: I make it more profitable for the hauler to come to me. Even though my rates are fairly competitive with those of municipalities, pumpers get in and out faster and can do more jobs. They make up

Pumper Interview

By **Scottie Dayton**

Pumper: What was your first treatment plant?

Macchio: Lindenhurst. I saw a need for treating wastewater from pumpers and cleaning companies since working at my family's business, RGM Liquid Waste Removal Corp. For 15 years, I envisioned a facility that provided better service than municipalities, remained open around the clock every day and catered to the needs of the industry. We sold RGM in 1998, and four years later I opened Lindenhurst. Orlando followed in 2004 and Elkhart in 2005.

The facilities are designed to get trucks in and out quickly. The volume at Lindenhurst is 400,000 gpd, where we have two double bays. Elkhart and Orlando have two single bays and are permitted for 500,000 gpd and 188,000 gpd respectively. The trucks discharge directly into automatic screening units, and personnel are present to sample the waste. They are trained that time is money for haulers, and getting them back on the road to their next job is the most important thing after acceptance and treatment quality control.

Pumper: What do you believe is the future of privately owned treatment plants?

Macchio: They supply a better service than government-run operations. Although the permitting and approval processes are daunting and the construction of plants expensive, I believe we'll see more. The permitting process is difficult because it involves the approval of local, state, and federal agencies. The public approval process involves hearings and overcoming the not-in-my-back-yard syndrome because of the odorous waste. Therefore, one of our main priorities and biggest

the difference that way, or by driving shorter distances, or by discharging at any time of the day or night.

Thirty different pumper companies use the Lindenhurst plant, 25 use the Elkhart plant, and 20 use Orlando. Like any business, you can't be sloppy. The plants aren't cash cows. They're businesses that require efficiency. You can make money if you're on top of the game.

Pumper: How involved is processing a combination of waste streams?

Macchio: Federal regulations don't allow the mixing of regulated wastes with unregulated wastes in certain processes, so we have different treatment trains. We can process septage, portable restroom waste, and grease together because they are unregulated. Depending on the state, sewage sludge might need separate handling, but industrial waste must be processed separately based on type and classification. Combine the two and the (U.S. Environmental Protection Agency) looks at it as dilution, so it's very important for plant operators to keep meticulous records.

Lindenhurst has three separate discharge lines and monitoring manholes before the effluent is mixed and released into the city sewer. One manhole is for unregulated wastes, the second for certain types of industrial wastewater such as pharmaceuticals, and the third is for landfill leachates and rinse waters. The other plants have one or two discharge lines and manholes.

Pumper: How do distance and the type of waste affect the competitive factor?

Macchio: Certain industrial waste streams can withstand a long haul. Septage and grease trap wastes usually require a disposal facility within 15 to 20 radial miles. Pumpers building treatment plants to service what they haul should stick with septage and unregulated waste. Those looking to enter the treatment business should consider processing the more complicated waste streams, but they require additional focus and energy because of the different treatments and regulations. ■

What's Your Opinion?

Pumper welcomes letters from readers responding to articles we publish or offering comments and opinions of interest to the industry. You can submit your letter by:

MAIL: Pumper, P.O. Box 220, Three Lakes, WI 54562
FAX: 715/546-3786 ■ E-MAIL: editor@pumper.com

All letters must be signed. Please limit your letter to 500 words or less. We reserve the right to edit all letters for length and clarity.



"Duel Power Lid"

Plugs, Lids & Adaptor Rings

Sizes Available: **18", 24", 30" & 36"**



Fergus Power Products
 Providing "Environmental Products"

The Company who maintains a pulse on the environment!
 Toll Free **1-800-243-7584**
 E-mail **fpproducts@prtcl.com**
www.FergusPowerProducts.com

WILCOX TRUCK SALES, INC.

Lowell, Arkansas **SINCE 1978**

I-540 Exit #78 & Hwy 71B
 2 hours East of Tulsa or 1.5 hours South of Joplin

Toll Free **888-207-2074** Fax **(479) 770-6089** www.wilcoxtrucksales.com

<p>1998 International 4700</p>  <p>New 2300 Gallon Vacuum Tank, with (2) 21" Domed Top Washout Manways, (1) 36" Rear Cleanout, (2) 1/2" Dished Baffles, New Juroop R260 Pump, DT466, Air Brakes, A/C</p>	<p>1997 International Paystar 5000</p>  <p>M11 Cummins, 330 HP, 9LL, Hendrickson, 4.89 Ratio, Budd Wheels, 208,776 Miles, 20/46 GVW, Quad Locks, New 100 Barrel Vacuum Tank, New Juroop R260 Pump</p>
<p>1999 Mack CH613</p>  <p>One Owner, New 80 Barrel Vacuum Tank, New Juroop R260 Pump, New Timbren Suspension Enhancements, E7 Mack, 380 HP, 9 Speed, Excellent 24.5 Radials on Polished Alcoa's</p>	
<p>1987 International F9370</p>  <p>Big Cam Cummins, 350 HP, 9 Speed, Hendrickson Suspension, 236" WB, Budd Wheels, 70 Barrel Vacuum Tank, Gardner Denver Pump</p>	<p>1993 Peterbilt 379</p>  <p>New 3360 Gallon Vacuum Tank, New Juroop R260 Vacuum Pump, One Owner, N14+ Cummins, 370 HP, 9 Speed, 240" WB, Fabulous Truck.</p>

"Just to let you all know, I did get my new AR-1 today. I played with it in my yard for about half an hour and put it to work this afternoon. I have to tell you this is the best tool I have ever invested in. I look forward to a long-lasting relationship with Prototek."

Thanks again,

Peter M. Christopher,
 Fairfield County Home Inspection L.L.C.
 Fairfield CT



"You are very welcome, Peter!"



Prototek

ECONOMICAL • EASY **800-541-9123**
www.prototek.net email: prototeksales@prototek.net



Old Pueblo Septic and Drain Service Inc.
Tucson, Ariz.

Owner: Scott and Amy Dugan
Founder: 1986
Employees: 15
Services: Residential septic and drain services since 1986

Service Area: Pinal County
Western Arizona
Old Pueblo Septic and Drain Service Inc.
1801 W. Alamo Blvd. Suite 100
Tucson, AZ 85705
Tel: 520-298-1100

IN GOOD HANDS

Evaluate the lessons and understanding of the business needed to be an elderly family ownership transfer for Old Pueblo Septic and Drain Service

By Jeff Conroy

When Scott and Amy Dugan founded Old Pueblo Septic and Drain Service Inc. in 1986, they were just getting started. Today, the company has grown into a successful business with 15 employees and a strong reputation in the Tucson area. The Dugans' story is a testament to the power of family ownership and the importance of proper planning for the future of the business.

Separation ANXIETY

Water Tech owners build their own custom solution offering simplicity and significant disposal cost savings

By Scott Dayton

When the Dugans decided to separate, they agreed that the best way to proceed was to sell the business. The new owner, Scott Dayton, took over the business and has since built a successful company. The Dugans' story is a testament to the power of family ownership and the importance of proper planning for the future of the business.

Water Tech owners build their own custom solution offering simplicity and significant disposal cost savings

By Scott Dayton

When the Dugans decided to separate, they agreed that the best way to proceed was to sell the business. The new owner, Scott Dayton, took over the business and has since built a successful company. The Dugans' story is a testament to the power of family ownership and the importance of proper planning for the future of the business.

Corvette package and employee loyalty

When the Dugans decided to separate, they agreed that the best way to proceed was to sell the business. The new owner, Scott Dayton, took over the business and has since built a successful company. The Dugans' story is a testament to the power of family ownership and the importance of proper planning for the future of the business.

On top of new technology

When the Dugans decided to separate, they agreed that the best way to proceed was to sell the business. The new owner, Scott Dayton, took over the business and has since built a successful company. The Dugans' story is a testament to the power of family ownership and the importance of proper planning for the future of the business.

REPRINTS AVAILABLE

Full copies of the original magazine
Hard copy color reprints
Electronic reprints

Visit pumper.com/editorial for articles and pricing

E-mail jeffl@colepublishing.com or call 800-257-7222

Featured in an article?

Make the most of it!

REPRINTS AVAILABLE

Full copies of the original magazine
Hard copy color reprints
Electronic reprints

Visit pumper.com/editorial for articles and pricing

E-mail jeffl@colepublishing.com or call 800-257-7222

Tanks Look

When the Dugans decided to separate, they agreed that the best way to proceed was to sell the business. The new owner, Scott Dayton, took over the business and has since built a successful company. The Dugans' story is a testament to the power of family ownership and the importance of proper planning for the future of the business.

On top of new technology

When the Dugans decided to separate, they agreed that the best way to proceed was to sell the business. The new owner, Scott Dayton, took over the business and has since built a successful company. The Dugans' story is a testament to the power of family ownership and the importance of proper planning for the future of the business.

Tanks Look

When the Dugans decided to separate, they agreed that the best way to proceed was to sell the business. The new owner, Scott Dayton, took over the business and has since built a successful company. The Dugans' story is a testament to the power of family ownership and the importance of proper planning for the future of the business.

REPRINTS AVAILABLE

Full copies of the original magazine
Hard copy color reprints
Electronic reprints

Visit pumper.com/editorial for articles and pricing

E-mail jeffl@colepublishing.com or call 800-257-7222

Tanks Look

When the Dugans decided to separate, they agreed that the best way to proceed was to sell the business. The new owner, Scott Dayton, took over the business and has since built a successful company. The Dugans' story is a testament to the power of family ownership and the importance of proper planning for the future of the business.

Corvette package and employee loyalty

When the Dugans decided to separate, they agreed that the best way to proceed was to sell the business. The new owner, Scott Dayton, took over the business and has since built a successful company. The Dugans' story is a testament to the power of family ownership and the importance of proper planning for the future of the business.

REPRINTS AVAILABLE

Full copies of the original magazine
Hard copy color reprints
Electronic reprints

Visit pumper.com/editorial for articles and pricing

E-mail jeffl@colepublishing.com or call 800-257-7222

Tanks Look

When the Dugans decided to separate, they agreed that the best way to proceed was to sell the business. The new owner, Scott Dayton, took over the business and has since built a successful company. The Dugans' story is a testament to the power of family ownership and the importance of proper planning for the future of the business.



Expect More Maintenance, Buy and Sell Inspection Requirements

By Tom Ferrero

An Oregon homeowner received a letter from his township saying he needed to hire a certified inspector to inspect his onsite system. He called for the names of NAWT-certified inspectors in his town. This is not an isolated occurrence.

Pumpers must become aware that maintenance and buy-sell inspections with pump-outs are coming. For example, Iowa's time-of-sale inspection bill took effect in July. Missouri, Massachusetts, Arizona and New Mexico (there probably are more) require inspections for the transfer of property. As of January 2006, Oregon required time-of-transfer inspections for all alternative treatment technologies. As of last April, onsite systems within the Delaware watershed must be inspected before property transfers.

Delaware's Class H Inspection Program requires mandatory pumping during inspections. The West Virginia Department of Health and Human Resources suggests an onsite system inspection every three years and a pump-out every three to five years.

California is battling over regulations requiring onsite inspections every five years and tank pump-outs when they are one-quarter full. If passed, the rule takes effect next July. Some states are building buy-sell inspections into their septic codes as they amend them.

Counties with watersheds often mandate onsite maintenance and point-of-sale inspections. Wisconsin's Wood and Vilas counties and the Land O' Lakes area require

an inspection every three years. It's also common in Minnesota. States write the rules, then let the counties implement the requirements, often without any input from the onsite industry. That's disappointing.

No one has ever controlled his destiny by sitting on his hands. Pumpers must be aware of what is happening at the state level and become involved in policymaking decisions. Many state onsite waste-

water associations are working in these areas, and those that are not, should be. People forget that the U.S. Environmental Protection Agency doesn't regulate onsite systems. It offers management guidance, funds installer and operation/maintenance credentialing, encourages NAWT, and encourages states to do management programs. The states have the authority to write rules.

As states update their septic codes, many require certification in all areas of the onsite industry, not just inspections. NAWT's training programs prepare pumpers to become competent inspectors. However, if we hold a training session in a state that doesn't require certification, nobody comes. That's sad, because pumpers who took our courses at the Pumper & Cleaner Environmental Expo International all said how rewarding they were, and looked forward to what came next.

Since we don't have courses all over the country, NAWT will offer its one-day vacuum truck technician training, two-day inspector training, and two-day, 12-hour onsite operations/maintenance course at the 2010 Pumper Expo.

What's the difference between the last two courses? Inspector training is geared

toward inspecting systems for buy-sell agreements. The operations/maintenance sessions follow the Consortium of Institutes for Decentralized Wastewater Treatment syllabus, but are modified to fit the allotted time. This is a good course for people who took our inspection training and now need eight hours of continuing education for recertification. It covers onsite systems from head to toe with an amazing number of checklists.

Management of onsite systems is coming, and as inspections become more sophisticated, the question of who does them arises. My son and his partner own a septic company in the Philadelphia suburbs. At least 12 municipalities in his service area have management requirements — all different. The rule to pump tanks every three years, however, is wrong. The NAWT approach is to inspect and evaluate each system individually. Pumpers know how to measure sludge volume in tanks. States should set the pumping standard at a percentage of the tank's capacity. Cleaning tanks unnecessarily doesn't make systems operate better, and too frequently could harm them.

Some Pennsylvania townships require a maintenance inspection every three years. They provide the inspectors. My son's company excavates and pumps some of the tanks. That's a step in the right direction because NAWT-certified pumpers are doing the work. We'd like our industry to provide the inspectors, too. The more pumpers who certify in these areas, the more control we have over what happens to our industry.

Yes, some municipalities have never heard of NAWT or the National Environmental Health Association Certified Installer of Onsite Wastewater Treatment Systems national credential. NAWT and NEHA are working with regulators to remedy that oversight through the Memorandum of Understanding partnership. Many agencies are members already. Last fall, the State Onsite Regulators Alliance joined the team. Sitting at the table with them provides the opportunity to demonstrate what NAWT and NEHA do, and the value of our training programs.

What good is certification if the paper means nothing to your local or state authorities? The time is coming when it will mean something. It's a long time out for the whole country, but it's happening now, every day, somewhere. Nationally recognized certification is coming, and it will be good for us.

DATES TO REMEMBER

The NAWT Waste Treatment Symposium is Oct. 9-10 at the Renaissance Orlando Resort SeaWorld (www.renaissanceseaworldorlando.com). To qualify for the hotel discount of \$150 per night double occupancy plus 12.5 percent taxes, register for your room by calling NAWT at 800/236-6298. These rates apply only for Oct. 8-9, after which they return to \$217 per night. The Water Environment Federation Technical Exhibition and Conference, or WEFTEC, follows at the Orange County Convention Center on Oct. 12-14. You'll want to stay for that event.

Registration to the Waste Treatment Symposium includes free admission to the WEFTEC exhibit hall on Monday (www.weftec.org), where you'll find many vendors with information on waste treatment. The symposium's registration fee is \$275 for NAWT members and \$375 for nonmembers. Sign up early, space is limited to 200 people. Download the registration form at www.nawt.org. Registrations must be received by Sept. 21. Don't miss seeing equipment process genuine septage and grease trap waste, and learning from the most competent, knowledgeable people in the field. ■

STATES SHOULD SET THE PUMPING STANDARD AT A PERCENTAGE OF THE TANK'S CAPACITY. CLEANING TANKS UNNECESSARILY DOESN'T MAKE SYSTEMS OPERATE BETTER, AND TOO FREQUENTLY COULD HARM THEM.

Tanks
made with
attention
to detail.



Amthor is Innovation

Looking for a new tank? Think Amthor.

At Amthor, we deserve our reputation for quality, innovation and expertise. Our products meet the demands of today's consumer AND exceed industry expectations. With a nationwide distribution network, delivery is simplified. Plus, you'll enjoy exceptional customer service. Visit us online for specifics.



www.AmthorInternational.com
For your nearest distributor contact: Hank Vanderveen
VA Office: 434.656.6233 • Tel/Fax: 252.293.1284 • Cell: 845.494.0104



Dyna-Vac Equipment

888-298-8668



Looking for *Power, Performance and Economy*... You Found it!!!
Sewer Cleaning, Hydro-Excavating, Catch Basin Cleaning
We Build What You Need....

Dyna-Lite

**Grease Trap Service
Equipment** designed for
*Fast, Professional
Service* with options and
accessories to get the job
done right!!



J
V
6
0
0



200 & 500
Gallon
Units

Dyna-Lite Trailer and Pump System

Highest Quality Vacuum Pumping Equipment

WWW.DYNAVACEQUIPMENT.COM



Our **VALUE** goes deeper than you realize.

When it comes to portable sanitation solutions, WALEX delivers much more than blue deodorizers and accessories. We're giving you **innovative research & development** that has set all the current standards for excellence. You're getting **proprietary breakthroughs** that our competitors can only emulate. When you choose WALEX, you're not only getting **the best on the market today** — *you're also supporting your industry's future.*



For more information, contact us at **910.371.2242**, toll-free **800.338.3155**
or visit our website at **www.walex.com**.

Truck Size Matters

A variety of factors help pumpers determine the size of a new vacuum rig

By Mary Shafer

One of the main considerations when purchasing a new vacuum truck is just how much truck you actually need. There are many factors to think about: average trip length, distance to disposal, type of jobs, location and size of the average customer's tank. All these factors help pumpers decide whether they choose a compact, agile vehicle or a hefty, roomy rig.

Because the vehicle will be a primary tool in revenue generation for years, and because it will be critical to efficient production on a daily basis, the decision is never lightly made. A significant, six-figure investment adds gravitas to the process.

Three pumpers share here what they think about when it comes time to retire an old rig for a replacement, or to accommodate the happy circumstance of expansion. When it comes to long-term profitability, one thing's for certain: Size really does matter.



Name:
Mark Booso
Company:
Booso's Septic Tank Cleaning
Location:
Lewisburg, Ohio
Employees: 2
Years in Business: 8

"Truck size is important," says Mark Booso, owner of Booso's Septic Tank Cleaning, which services the east-central portion of the Buckeye State. "What you drive has to fit what you do." Situated about halfway between Dayton and the Indiana state line, Booso primarily serves suburban and rural customers with septic

pumping, inspection and the installation of risers and baffles.

After you decide what you need, he says, "The biggest consideration is money — what you can afford. And it's not just buying the truck you have to think about. There's the cost of keeping it up: regular maintenance, the tires underneath. That's all part of the long-term cost, and you have to remember that."

He says that the biggest disadvantage of larger trucks for his business is that some of his smaller trucks already have trouble fitting between big trees and buildings, or down a narrow drive. "I think we'd also have problems with some customers who'd be afraid a bigger rig might hurt their driveways."

He runs smaller trucks, Ford L7000 bodies with tanks averaging 1,500-gallon capacity. He says he doesn't see moving up to anything larger any time in the near future.

Comments may be directed to Mary Shafer in care of Pumper. You may also e-mail pipelines@pumper.com.

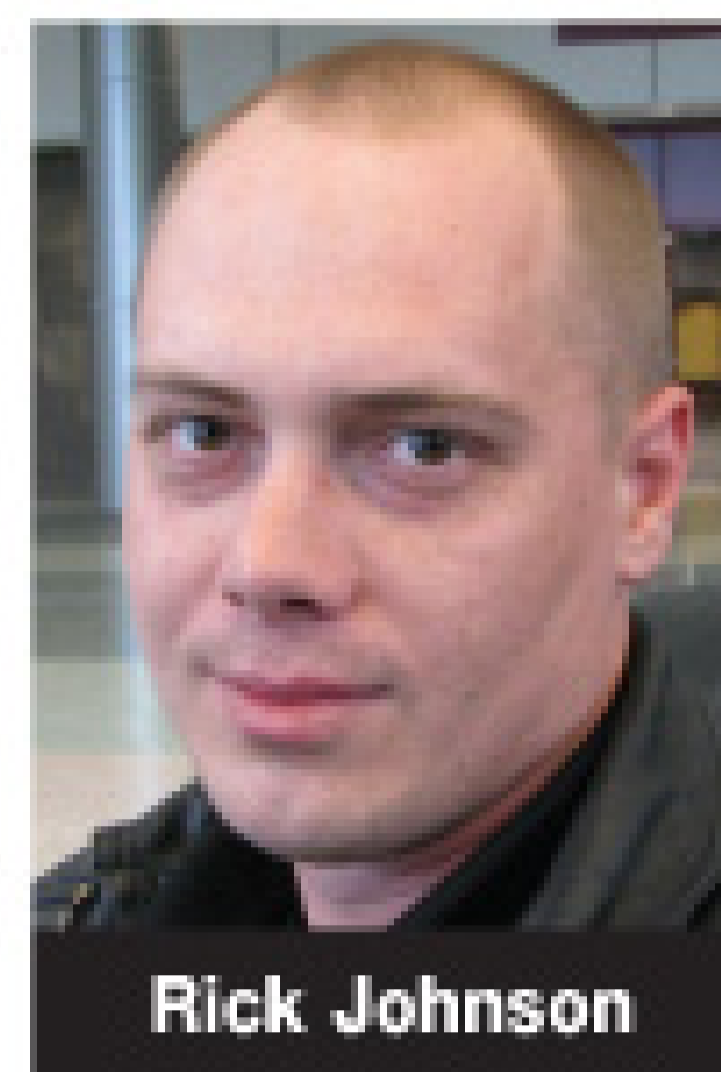

Name:
Rick Johnson
Company:
AAA Drain Doctor
Location:
Waterloo, Iowa
Employees: 17
Years in Business: 35

For AAA Drain Doctor, the pressure's on to go bigger, but the downward pressure of the economy is more powerful for the time being. The company performs residential and commercial septic pumping, drain cleaning and relining for customers in northeastern Iowa. Its fleet includes two 3,600-gallon

vacuum service trucks.

"In our area, we've got new mandates from the municipal plants where we dump that say even if we bring in half a tank or just a single load, we get charged the same as a full load," says technician supervisor Rick Johnson. "So we're definitely going to be looking at going with bigger trucks."

This move, he says, would help the company achieve economies of scale by being able to run more or longer routes before having to make a disposal run. It would also allow the pumpers to make sure their tanks are as full as possible, to get their money's worth at the plant.

Economic considerations right now are holding the company back when it comes to making fleet upgrades. New truck purchases will have to wait until business becomes more regular and can sustain that expense. "We'll have to wait until more of our corporate customers go back to preventive maintenance and there's more work for the trucks to do," Johnson says.

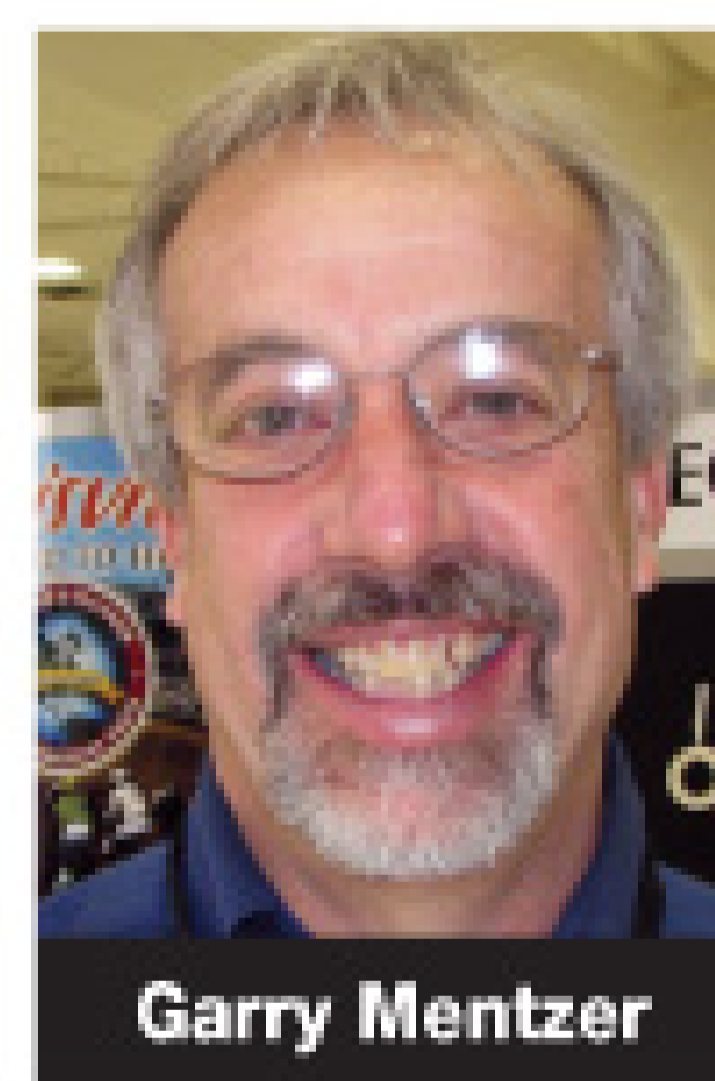

Name:
Garry Mentzer
Company:
Reliable Sanitation/
G.D.M. Inc.
Location:
Colorado Springs,
Colo.
Employees: 12
Years in Business: 35

"We have gone bigger where we need to," says Gary Mentzer. His company, Reliable Sanitation/G.D.M. Inc., services the Pike's Peak region of central Colorado. "We have all different size trucks, small trucks that handle small jobs, large vehicles we can use to handle multiple-site jobs."

The firm, which operates five smaller companies under the umbrella of G.D.M. Environmental, performs septic and grease trap pumping, and sewer and drain cleaning for residential, commercial and municipal customers. It fields a fleet of about 30 vehicles, most of them Kenworth trucks. The company's largest vacuum truck has a 4,000-gallon tank, "only because of (Department of Transportation) weight restrictions," says Mentzer. He would clearly like to run larger trucks, but his territory's spread-out nature requires them to go over too many smaller, weight-restricted bridges.

"I don't think there are too many cons to running larger trucks, when you think of advantages and disadvantages," he says. "I think it's

"In our area, we've got new mandates from the municipal plants where we dump that say even if we bring in half a tank or just a single load, we get charged the same as a full load. So we're definitely going to be looking at going with bigger trucks."

Rick Johnson

Tell us what do you do After Hours

After Hours is a new feature in *Pumper* exploring what business owners do and issues they face outside of the workplace. Topics may include interesting hobbies, unusual side businesses and pursuits, personal challenges (like coping with long-term health issues, taking care of parents, running a marathon, etc), helping family members reach their goals or charitable pursuits.

We explore topical issues like balancing work with family time, fitness and travel, working toward financial goals or retirement, or other general lifestyle or "human interest" stories.

If you know of someone in the industry who would make an interesting human interest story, please call Jim Kneiszel at 866/484-6131 or e-mail him at editor@pumper.com.

really something where the pros outweigh the cons when it comes to going bigger. In our area, most of the smaller guys are getting bigger trucks so they can do more jobs. Probably the biggest issue driving that has been fuel costs. If they can stay out and keep pumping and not have to go back and forth to dump, that saves them some money." He notes that fuel prices have been going up and will continue to be an issue.

Mentzer acknowledges that challenging terrain in mountain and hill country may help dictate the trucks chosen by some contractors. "The really large (industrial vacuum) trucks we have, we try to keep off the big hills (of the Rocky Mountains)," he says, but it isn't due to the steepness of grade or the thinner, engine-stalling atmosphere, as one might suspect.

Instead, it's because there's more chance for these large rigs to get stuck on uneven terrain. "We do take these trucks into some of the more 'off-road' type areas, if the majority of the ground is flat. We just pull them as close as possible (to the pumping site) and bring extra lengths of hose to cover the rest of the distance." ■

Everyone's talking about it.

Find out why.
Get your **FREE** subscription today.

ONSITE installer PROMOTING WASTEWATER TREATMENT
QUALITY AND PROFESSIONAL EXCELLENCE

Visit www.onsiteinstaller.com or call 800-257-7222.

The ALL New Comfort Elite

- Hydraulic Lowering System: no steps, platforms or railings
- 20' modular unit features 10 private unisex restrooms
- 4-sink exterior handwashing station
- Vacuum Macerator Pump System: allows for direct sewer connection, doubles usage capacity and low fresh water demand

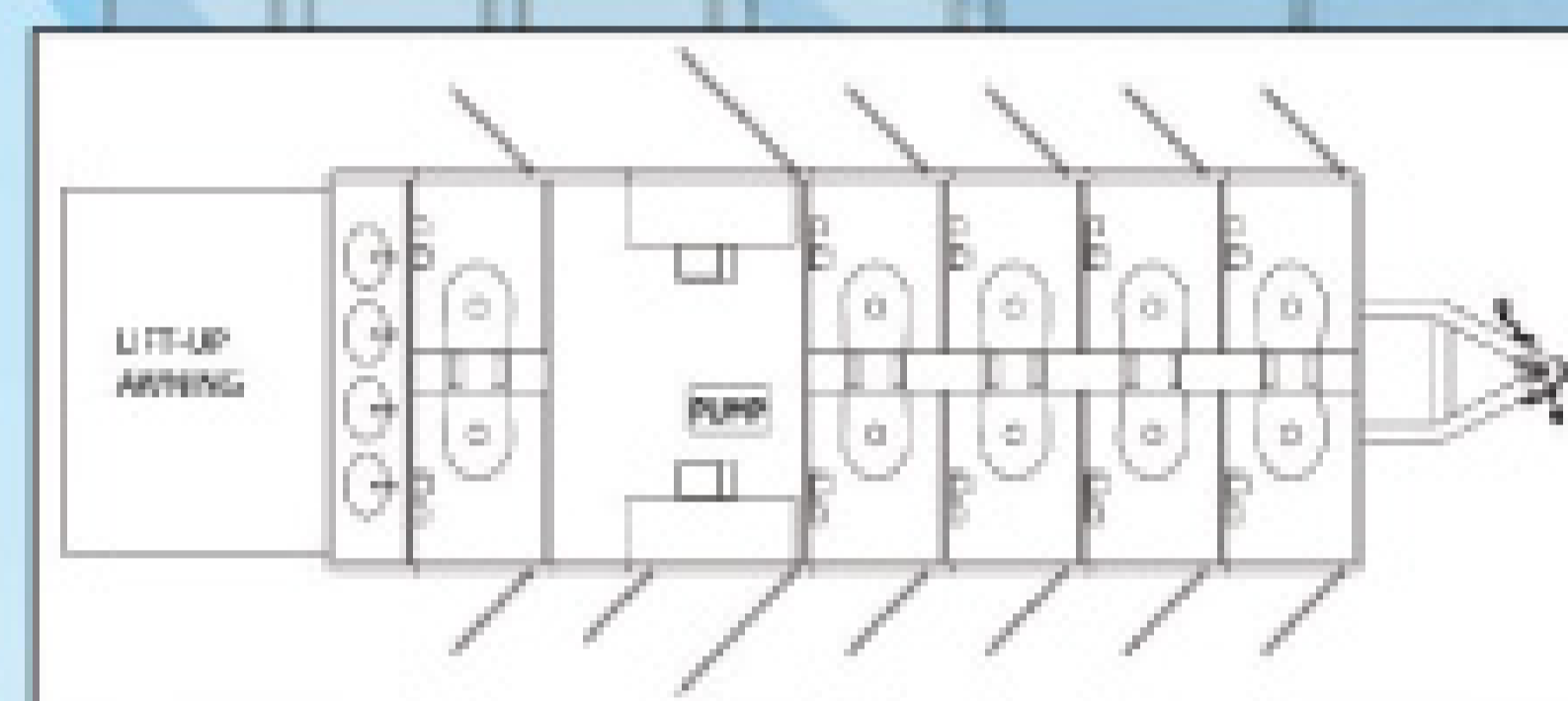

Wells Cargo COG

Effective Solutions. Uncompromising Quality.

Phone: (888) 574-4222

Web: www.wellscargoCOG.com



Belt Filter Presses For:
Grease Trap
Septage
Industrial Waste



GOT SLUDGE??

Dewatering made Simple
Get the Real Answers!

www.brightbeltpress.com
Tel: 269-793-7183 - Fax 269-793-8793
127 N. Water Street, Hopkins, MI 49328
MADE IN THE USA

Call today for More information!!
800-253-0532



In these tough economic times, trust the experience that
52 YEARS OF MANUFACTURING
and a dedicated team of professionals can bring you.

FRUITLAND VACUUM PUMPS



Tool & Die Maker
42 yrs.



Machinist
26 yrs.



Machinist
43 yrs.



Tool & Die Maker
29 yrs.

*"A Few of our
Long Term
Professionals"*



Markets:

- Industrial •
- Oilfield •
- Septic •
- Grease •
- Environmental •
- Wastewater •

**Used and Proven by
World's Top Liquid
Vacuum Service Companies.**

Fruitland Tool & Manufacturing

"Committed to Quality, Reliability, and Guaranteed Performance"

Contact us today: **1-800-663-9003**
 Visit us @ www.fruitland-mfg.com For more info.



Aqua-Zyme Disposal Systems

*"From the Grease Trap to the Garden"
- Dewatering & Composting -*

#1 Box on the market!

The ADS Dewatering System

is built by a pumping company for pumpers. You are welcome to come and watch the 30 yard box dewater 20,000 gallons of grease trap waste and/or septic tank waste in only 2 hours!

By using the ADS dewatering system along with our Compost Facility, we have turned our disposal costs into a profitable venture!

Call 979-245-5656 for Info!
\$ Financing Available \$

P.O. Box 489, Van Vleck, TX 77482 • www.aqua-zyme.com
 1-979-245-5656 • zymme@aqua-zyme.com • U.S. Patent # 6,364,122



Filter Box Interior

Draining Down

Up to \$7,500 off all 2008 inventory.*

NEW AND PRE-OWNED SALES | RENTAL | LEASING | PARTS | SERVICE | BODY SHOP | FINANCING

If you're in the market for a refuse vehicle, make Rush Refuse Systems your resource. We have one of the largest inventories of work ready trucks in the country, representing the industry's leading brands. Whether you need to buy, rent or lease, we have a full spectrum of financial resources available. And, we support you through our Rush Truck Centers network of over 50 locations — with an extensive parts and accessories inventory, highly skilled ASE-certified service professionals and exceptional body shop capabilities.

Last DOT Vacuum Tank in Stock.



Peterbilt 340 Standard Vacuum Trucks

Automatics and standards in stock ready to go to work. Non-code 3600 gallon Pik-Rite tank. Masport HXL400WV liquid cooled pump, aluminum hose trays, internal primary to secondary piping for clean mount. 10 yr tank warranty standard. Options can be added before delivery. Compare our standard specs to anybody! **Call for pricing.**



Peterbilt 340 Industrial Vacuum Truck

Allison 3000 RDS automatic transmission, PACCAR PX-8 330HP DOT 407/412 3150 gallon Cusco units. Moro PM100 pump, hydraulic full opening rear, vibrator box, air actuated valves, full walkway with handrail, 20 ton dump capacity cylinder.

**Close out pricing – was \$159,900
now just \$154,900.**



2008 Peterbilt 365 with 4200 Gallon Oilfield Vacuum Tank

Standard transmission in stock ready for delivery. CAT C13 430HP. Pik Rite 4200 gal steel tank. Masport HXL400WV liquid cooled pump. Aluminum hose trays. Options can be added before delivery. **Call for pricing.**



2009 Peterbilt 340 with 4000 Gallon Aluminum Vacuum Tank

Automatic or standard in stock ready to go to work. Imperial 4000 gal aluminum tank. Masport HXL400WV liquid cooled pump, Aluminum hose trays. Options can be added before delivery. Two Stage engine brake included. **Call for pricing.**

877-661-4511

Refuse Sales Team: Gregg Wilkinson | Jason Guzauskas | Jesse Fullilove | Ryan Johle
refusesales@rush-enterprises.com | 8810 IH-10 East | San Antonio, TX 78219

*Prices listed here include discount and FET, and are subject to any state and local taxes. Discounts vary based on list price and age of vehicle. Prices subject to change. See your Rush Refuse Systems representative for complete details.

Refuse Systems



www.rushrefusesystems.com



PORTABLE TOILET
SERVICE UNITS
SLIDE IN UNITS
HOISTED UNITS
ROLL OFF UNITS
CUSTOM UNITS

www.pikrite.com

pikrite

Manufacturing & Sales - 60 Pik Rite Lane - Lewisburg, PA 17837

1-800-326-9763



WHIRLWIND AERATOR



Best Value!

The **STA60** and **STA80** are specifically designed for years of trouble-free service and is a superior replacement for all 60 and 80 model pumps on the market.

CARRIES A 2-YEAR WARRANTY



BIO Control Panel
with Lift Station,
Aerator, Timer
& High Water
Alarm

BULLET

**High Head
Filtered
Effluent
Pumps**



Flagg-Air Model 340

- 3450 rpm
- 1/4 hp, 115V
- Enclosed motor
- Stainless steel shaft
- High impact plastic parts
- Operates quietly
- 2-yr. warranty
- Fits in place of most original manufacturers' units
- Replacement parts available



The Flagg-Air 340 does not carry the NSF seal. Check local and state regulations for approval in your area.

MEDO HEM LA-80 Linear Pump



with low pressure
alarm & light;
with on & off
switch

MEDO Piston



LA-60
LA-80B
LA-100
LA-120

SECOH Diaphragm



EL 60
EL 80
EL 100
EL 120

GAST
0523
1023

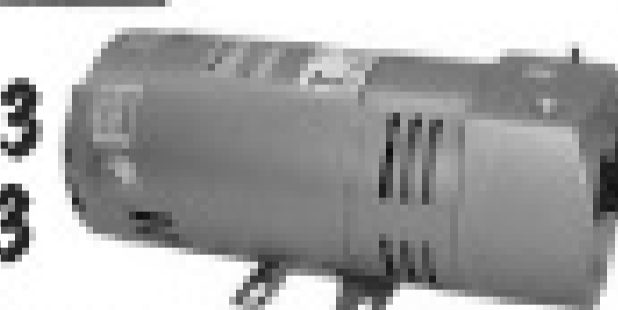

Rotary Vane
Compressor

Regenair®

R3105-12
Blower

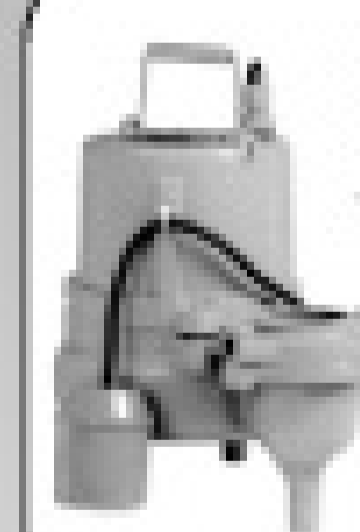

Hydromatic,
Zoeller, ABS,
Liberty &
Myers
Pumps

Conde SDS 6 Engine Driven



Units available
20 to
180 cfm



**Moro PM80
Turbo 350 cfm**
Moro Pumps: from 176 to 1642 cfm



Septic Services, Inc.



toll free **1.800.536.5564** • 636.583.5564 • fax 636.583.6432
e-mail septic@fidnet.com • web www.septicserv.com

**Don't put your crew in danger
or pay costly fees for damages**



Not only do we give you the best **quality** - our trucks and equipment are the **easiest to operate**, provide the **safest** operator positions, are the most **fuel efficient**, have the **lowest maintenance costs**, and have the **highest resale value!** GapVax® units have **no visible dust emissions**. We **CUSTOM** build to your specs. We have a **PATENTED** superior filtration system that saves you money and provides a longer life for your GapVax® and parts/accessories! So if you're thinking about buying not only is **NOW** the time but we're your **#1 choice!**

Get GapVax®

INDUSTRIAL VAC TRUCKS
HYDRO-EXCAVATORS
COMBINATION JETVACS
WETVACS
SKID MOUNTED VACUUMS
CYCLONE TRAILERS
BAGHOUSES
CYCLONE AUTO-LOADERS...

**ALL sizes,
custom built for you.**

Call today!!!
888-442-7829
toll-free US/Canada



PARTSEXPRESS
A DIVISION OF GAPVAX

*The Perfect Fit
for ALL your parts
& accessory needs!*

~ Visit

www.gapvax.com

to check out our videos and testimonials ~

Stop Short on Trenches?

More research is needed to determine whether new distribution media products require smaller drainfields

By Roger E. Machmeier

Q Some manufacturers of newer types of distribution media say the size of a drainfield trench can be reduced over traditional installations using rock because the distribution media is more efficient. I have been doing that and the trenches seem to be working OK. Do you think it's OK to reduce the length of trenches from what would be required for rock?

A I think the jury is still out on your question. Unfortunately, there was not a great deal of research available to establish the original numbers we now use for sizing soil absorption systems. However, those numbers have been used for many years and are still generally accepted for a rock-filled system. This system would use 3/4-inch-plus rock as the distribution medium.

There are a number of manufacturers selling distribution media other than rock for drainfield trenches and other soil absorption systems. Most manufacturers offer various technical reasons why the size of the soil absorption system can be reduced when using their distribution medium. However, I am not aware of any physical information on the actual performance of these various systems.

MONITOR THE SYSTEM

It is simple to monitor the performance of any drainfield trench system. If the new systems were monitored, the manufacturer of the distribution medium would have performance field data valid for the sizing of future systems. The procedure would be to first carefully analyze the soil texture where the trench system was to be installed.

The total length of trenches designed for the system should be divided into a number of shorter trenches. The shorter the individual trench length, the more accurately the performance could be evaluated. Effluent should be fed into the trenches using sequential distribution with a drop box at the head end of each trench.

The first trench in the system will be filled to maximum treatment capacity before any effluent will flow to the second trench. A drop box at the head of the first trench is required for this to happen. When the first trench is full, the extra effluent flows to the second trench, and so on. Each trench must have an inspection pipe at the far end so the effluent depth can be measured and recorded.

CALCULATE FLOW

When the onsite sewage treatment system reaches equilibrium, the total amount of trench length being used can be measured and recorded. Trench length is only part of the information required. The other essential information needed is the amount of sewage flowing into the system. The amount of sewage flow will vary from day to day, so an average daily rate of flow will need to be calculated.

The sewage flow rate can easily be measured with a simple water meter. The meter is connected into the water system piping to measure only the water used in the home. The piping for outside faucets should bypass the water meter. On a new house, such piping can easily be arranged. It may be a little more difficult on existing water system piping.

The water meter does not need to be of the quality used by cities. A

water meter having an accuracy of 1 percent is adequate. Such water meters are likely available for less than a hundred dollars.

The object is to get the average daily rate of flow into the sewage treatment system. The other information is the amount of drainfield trench being used.

WATER METERS REQUIRED?

The average daily flow rate, together with the length of trench being used will give an important design value. This will be the number of gallons of sewage per day per foot of trench. And this is the value the manufacturer of distribution media should have for their product.

The same procedure should be used for drainfield trenches using rock. Unfortunately, again there is not much valid data on trench performance using drainfield rock.

Most of the distribution media manufacturers use the design table for rock-filled trenches. They reduce the area required by an amount that makes their product price competitive with rock.

I understand some states now require water meters be used with new types of distribution media. I don't know if there is a reporting system set up to collect valuable data for the onsite industry. It would be a good idea to involve the local permitting agency when collecting performance data on any onsite system. This would make the information public and not subject to question about accuracy.

You stated the systems you installed with reduced area were working "OK." To me this simply means the amount of sewage flow is not greater than the amount the system will treat.

Roger Machmeier, Ph.D., P.E., retired as an Extension Agricultural Engineer for the University of Minnesota and is a past recipient of the pumping industry's Ralph Macchio Lifetime Achievement Award. He answers reader questions regarding septic system operation and maintenance. Contact Machmeier through COLE Publishing by e-mail at editor@pumper.com, by fax at 71/546-3786; or by mail at P.O. Box 220, Three Lakes, Wis. 54562.



When an onsite sewage treatment system is designed, the average daily sewage flow rate must be established. Most onsite codes use the number of bedrooms to predict the sewage flow rate.

It is typical to use an estimated sewage flow rate of 150 gpd per bedroom. If a four-bedroom house is built, the estimated daily sewage flow rate will be 600 gpd. If the house is occupied by a couple who are both employed and have no children, they will not use an average of 600 gallons of sewage per day.

And, let's say a reduced area soil absorption system is installed for this house. Of course the system will work "OK" since the sewage flow rate is considerably reduced from the design value. But this doesn't necessarily mean the reduction in area from rock sizing is valid. It simply means the reduced area drainfield is working because the sewage flow is reduced from the value used to size the system.

BETTER PERFORMANCE EVALUATION

Research I was involved with at the University of Minnesota measured sewage flow rates from 10 homes. As I recall, the average flow rate from those homes was about 60 percent of the amount used to size the trench system. Reduced area systems would have worked well for those homes because the sewage flow rate was reduced.

In summary, the onsite sewage treatment industry needs to do a much better job of monitoring and evaluating the performance of all onsite systems. Accurate performance data is needed for the design of future innovative systems. ■



**PRO's #1 CHOICE
IN DEODORIZERS!**

TRUEX 70-10 NON-FORMALDEHYDE
SUPER CONCENTRATED EXCLUSIVE SPECIALTY FRAGRANCES

55 gallon drum was ~~\$1475~~ea now **\$1350**ea*

TRUEX 70-12 NON-FORMALDEHYDE
ULTRA CONCENTRATED EXCLUSIVE SPECIALTY FRAGRANCES

55 gallon drum was ~~\$1795~~ea now **\$1575**ea*

* Delivered Pricing In 48 Lower Continental States
VOLUME DISCOUNTS AVAILABLE

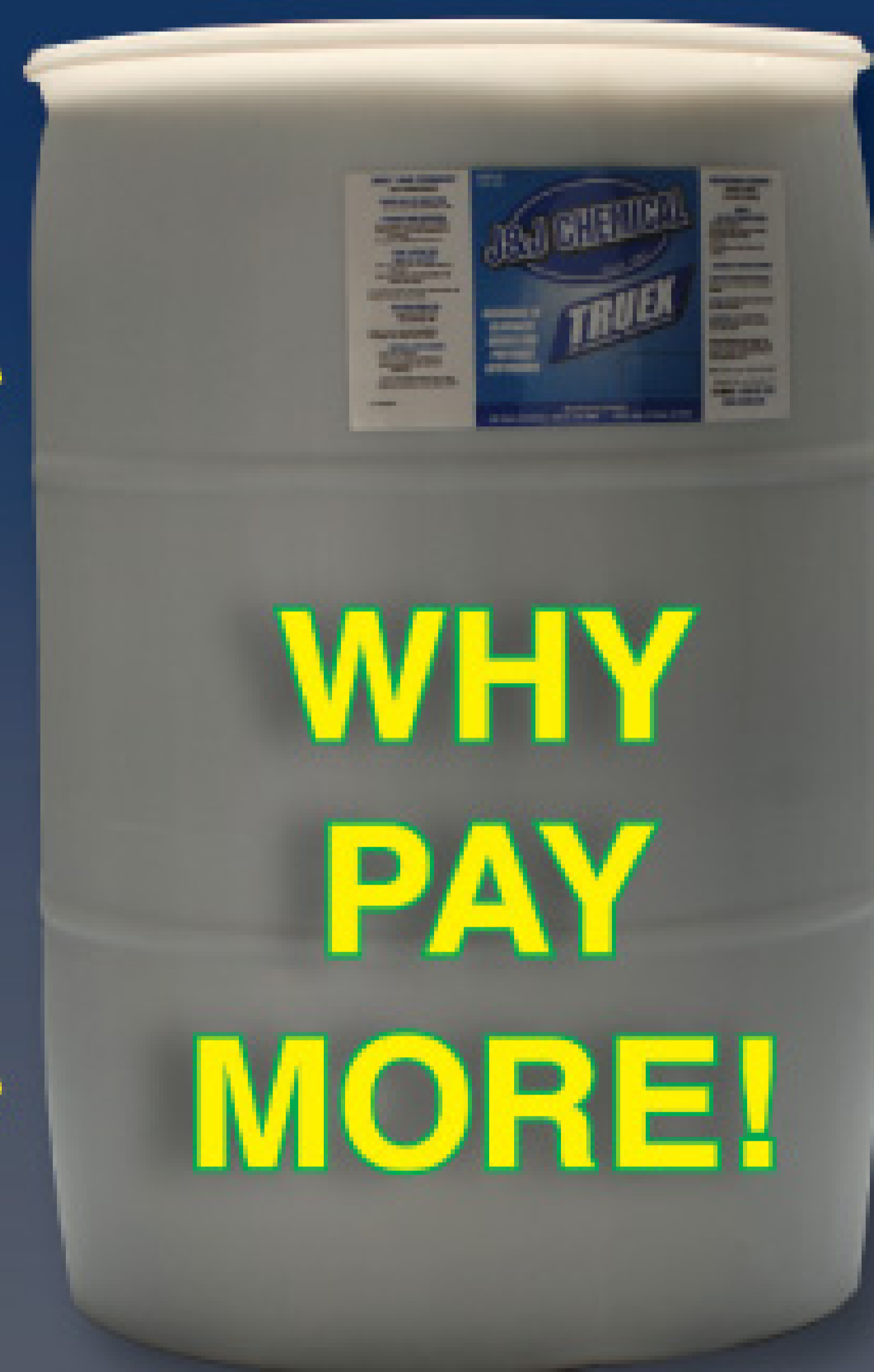

EXCLUSIVE SPECIALTY FRAGRANCES
SUNBURST • FRESH SCENT • MELON BREEZE • SUMMER LINEN

**HOW MUCH WILL OUR VALUE PROGRAM
SPECIALTY FRAGRANCES SAVE YOU THIS YEAR?**



CALL TODAY AND SAVE BIG!
1-800-345-3303
www.jjchem.com



IN STOCK! Drive Away Today! **Financing Available.**

New! 3600 Gallon Aluminum Front Hoist Septic Service Tank

Rear Opening Door

6" discharge / 4" inlet
Robuschi 65 Series 912 CFM blower package.

2008 7500 Series International

350 HP, 10 speed transmission, diff locks,
18,000 lb. front axle.

\$144,500

Masport HXL400 Water Cooled Pump
6" Rear Discharge / 4" Inlet
Large Tool Box

Refurbished! 2005 Mack CX613

330 H.P. Mack engine
10 speed trans., Double frame
14,600# front / 40,000# rear

\$87,350



2000 Gallon Septic Pumper

Masport HXL75 pump, tool boxes.

2008 Toyota Hino Model 338

6 speed trans., air brakes

\$79,849

Refurbished 2005 Mack

Front axle: New king pins, bushings & brakes.
Engine: New rod & main bearings & rear main seal
New clutch
Rear air suspension: New bushings and brakes
New virgin tires. New paint.

'Limited Drive Train Warranty'

888-848-3727

L.C. TANKS LaVerne Charlet

email: lctanks@bellsouth.net fax: 270-898-4055
175 Cascade Dr, Paducah, KY 42003

Aluminum, Steel & Stainless Steel Tanks Available

1200 Gallon Septic Pumper

Masport HXL75 pumping system.

2008 Sterling Bullet

84" C.A.
305 HP
Auto. trans.
Hydraulic
brakes

\$69,750



Tanks For Your Business

Mid-State Tank manufactures stainless steel and aluminum tanks and has become a well-known and respected supplier for the agricultural, aviation, industrial and fire services, as well as pressure/vacuum tanks.

Mid-State Tank holds an ASME stamp and is D.O.T. approved.



Mid-State Tank Co., Inc.

PO Box 317 • Sullivan, IL 61951
(800) 722-8384 • Fax: (217) 728-8384
www.midstatetank.com



\$ We've Got the Money \$

For All Your New and Used Equipment Needs

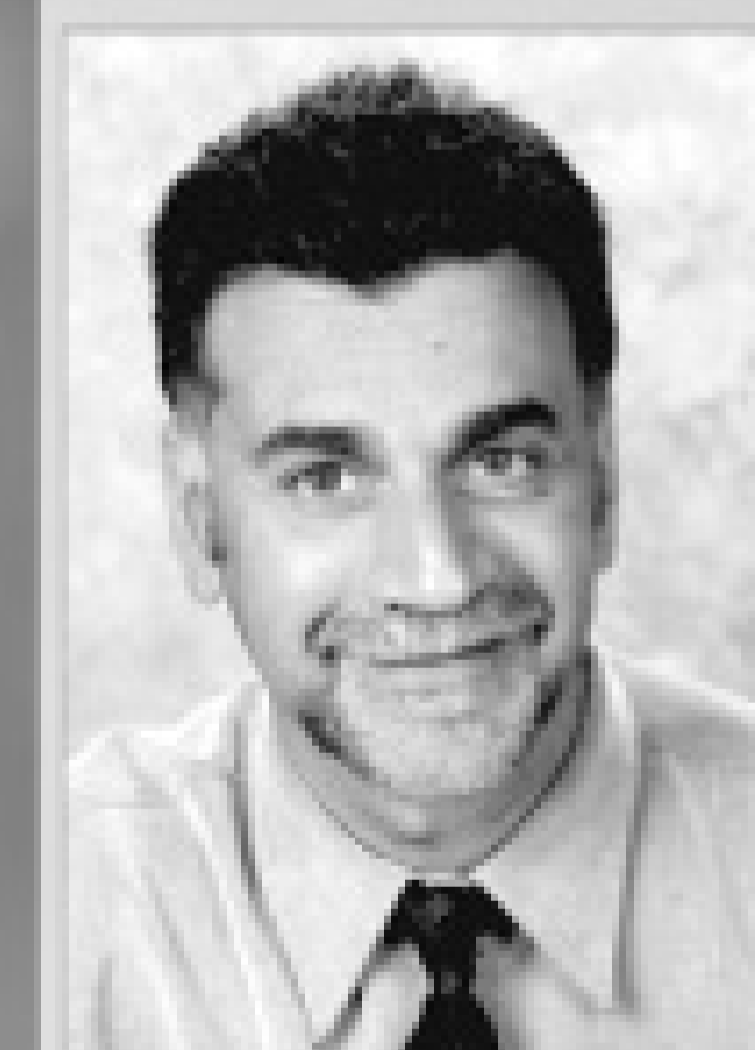

Chuck Territo



Mike Rausch

- \$250k Application Only
- Simple Approval Process
- Lease or Loan Options
- New & Used Equipment
- Flexible Finance Options
- Start Up Programs

Let us put our 35 years of experience to work for you! Call today and see why...

It pays to lease with us!

Granite Leasing Co.

800.246.7997

www.graniteleasing.com



300 US GAL to 15,000 US GAL Capacities



1-877-837-7323

www.nuhn.ca

nuhnind@nuhn.ca



4TH Annual WASTE TREATMENT SYMPOSIUM

Don't miss this **Opportunity** to learn about technologies first-hand!

- ✘ Hear presentations on treatment technologies
- ✘ See equipment process real septage and grease trap waste
- ✘ Build connections with industry leaders in treatment technologies

Finalize your plans for the NAWT 4TH Annual Waste Treatment Symposium, held on **October 9th and 10th, 2009 in Orlando, Florida at Select Processing of Orlando**. Call the NAWT office for the NAWT special rate of \$150 per night plus 12.5% taxes for October 8 and 9.

2-Day Agenda. The Waste Treatment Symposium provides two days of opportunities to see septage and grease trap waste treatment equipment and technology presented by serious professionals.

Name: _____
 Company: _____
 Address: _____
 City, State, Zip: _____
 E-Mail: _____
 Phone: _____ Fax: _____
Registration Fee: \$275.00 – Members \$375.00 – Non-Members
 Check enclosed Visa MasterCard _____
 Exp. Date: _____ Name on Card: _____
 Signature: _____

Fax or Send your form with payment to the NAWT office by **October 1, 2009**. See www.NAWT.org for updates

336 Chestnut Lane, Ambler, PA 19002-1001
 Fax registrations with payment information to **267-200-0279**
QUESTIONS? Call NAWT at 1-800-236-6298



Getting Credit

Maintain a good credit rating and you'll still find financing at a time when money's tight

By Erik Gunn

The headlines have been filled with stories about the credit crunch. Consumer lending is tighter, and loans for business have become much harder to get.

The smallest businesses aren't immune. In a recent National Small Business Association survey, one-third of firms with less than \$5 million in annual revenue and fewer than five employees said access to capital was the biggest challenge they faced. Fully 45 percent said their business had been "significantly or moderately" affected by tight credit. So where does that leave you?

Times like these offer a hard lesson in the value of managing money carefully, even when times are good. The more you've done in the past to ensure a good credit record for your business, the better off you are likely to be now.

They're also a lesson in the importance of business by relationship: You will have a much easier time with your banker if you're an established customer, instead of just a stranger off the street who needs a loan.

"Banking has always been and will always be about relationships," says Rose Oswald Poels, senior vice president and general counsel for the Wisconsin Banking Association. "You want to do business with a lender who does know you, knows the type of work ethic you have, and has a history with you."

But neither your past record nor a good relationship guarantee you'll get credit in the face of much tighter lending standards. They'll get you in the door, but you'll still need to make the case for the loan you seek when you seek it.

WRITE A PLAN

That means focusing more than ever on the business plan you write to support your request for credit. And it means making sure the plan is well supported by facts you can back up, not just wishful thinking.

If you're seeking financing for a startup operation, "You need to go into a bank with solid marketing plans, some demonstrated skill in terms of the people who will be running the business, as well as some kind of cash flow or collateral to prove that you're a good credit risk," Poels says. Elementary as it may sound, positive cash flow is crucial. Without it, your lender has no guarantee you'll be able to pay back the money, no matter how good the terms.

If you get turned down, it's not the end of the world. "You have to understand the reason for the denial and see if there are ways you can correct that," Poels says. "If the turn-down for the loan is more tied to insufficient market research or insufficient proof that the business is viable, things like that are easier to correct."

The solution: Beef up your research and the evidence that your business is operating on sound fundamentals, then go back and ask again. Some reasons for denial may be harder to overcome: for example, you're already carrying so much debt that you have very little equity in your business free and clear.

Erik Gunn is a magazine writer and editor in Racine, Wis. Readers may direct inquiries to him by contacting this publication at 800/257-7222 or e-mailing editor@pumper.com.



"You need to go into a bank with solid marketing plans, some demonstrated skill in terms of the people who will be running the business, as well as some kind of cash flow or collateral to prove that you're a good credit risk."

Rose Oswald Poels

REALITY CHECK

That's when you need to step back and look at the business with a much clearer eye. "The business has to have a reality check," says Ellen Thrasher, director of entrepreneurship education for the U.S. Small Business Administration.

The SBA has programs to guarantee loans made through private-sector banks (visit www.sba.gov/services/financialassistance and www.sba.gov/localresources). But you may need to accept the fact that you can't get the credit you want now.

In that case, Thrasher suggests focusing on three aspects of the operation: overall sales performance, ongoing financial condition, and how you, as the owner, are functioning as the face of the business. She calls it "focusing on a plan for success."

Trim expenses. Look hard, and enlist your workers in the hunt. "Sometimes employees are a pipeline for the best ideas," Thrasher says. Streamline your operations any way you can that will help your operations.

Boost your savings. You can't get more financing now? Then make the hard decision to lower your sights, but also look to the future. Take the money you would have spent repaying the loan and see if you can set aside at least some of it to reserve for down the road, when circumstances make financing more available. That way, you'll have more seed money, which is likely to improve your chance at getting your lender to say yes.

Empower the workforce. Don't stop with cutting costs. Meet with your workers daily and get them involved in communicating with your clients or your vendors. "Delegate smaller projects to them so you, as the business owner, can free up time to market overall," Thrasher says. Find free or inexpensive ways to promote your business and grow sales.

Update your Web site or create a new one. Offer yourself as an expert to local community newspapers. Look into how you can use Internet social networking sites like Facebook to promote what you do.

Become your own best salesperson. Don't just market to new clients — cultivate existing customers.

Ask for help. Successful small businesses often get help from an outside board of advisors who can lend strategic guidance. Others turn to groups like SCORE (www.score.org) or Small Business Development Centers at their local college or university.

PLAN FOR TOMORROW

Yes, things look tough. But it's important not to get bogged down in the gloom. If nothing else, take a deep breath and say to yourself, "This, too, shall pass." Things will get better, credit will flow again, and business will improve. When it does, don't forget the lessons you're learning now. They'll help you make the best of things when times are good again. ■

\$2,000 OFF OVERSTOCKED MD1250's



As low as **\$67,748**

CLASSY 950's



As low as **\$56,777**

CUSTOM SEPTIC



1200-7000 Gallons

Satellite

For All Your Trucking Needs Call:
800-328-3332



DENVER TRUCK SALES

Nobody
Beats Our
Quality!



Tanks
Manufactured
In House

2001-2005 IHC 9900-5900

14,000 - 20,000 lbs. FA. ISX Cummins, 475 HP, Jake, 18 speed transmission, RT-46160 on 46,000 lbs. air suspension, double frame, 4-way locks, New 3360 or 3750 Gallon Tanks, 400 CFM pump, New paint, serviced and checked, NAP.

From **\$59,950** plus F.E.T. on the tank (n.a.p.)



500-4000

Single or 2 compartment vacuum tanks with pumps, tank options mounted on your truck or ours.

Call for special prices. (n.a.p.)



Complete Lines of
Pumps and Parts

2001-2002 Western Stars 4964 SX

16,000 lbs. - 20,000 lbs. FA., 475 Cats., Jakes, 18 speed transmissions, 46,000 lbs. rears, air suspension, 3360 and 3750 Gallon Tanks, 400 CFM pump, New paint, service and checked, NAP.

From **\$59,500** plus F.E.T. on the tank (n.a.p.)



2002-2003 KW-T-800

14,600 lbs. - 20,000 lbs. FA, C-15 Cat 475 HP, Jake, RTLO-16918 transmission, RT46160 46,000 lbs. rears on air suspension, new 3360 gallon tank, 400 CFM pump, new paint services and checked.

From **\$69,950** plus F.E.T. on the tank

Easy Financing and Lease-To-Own WAC!

Denver Truck Sales • 5293 Vasquez Blvd. • Denver, CO 80216

Phone: 303-291-0960 • Fax: 303-291-0244 • www.denvertruck.com

Introducing the Most Durable
and Economical Septic Lid in
the Market Today.

Cost Effective
6 Pack
Shipping

Now Offering
**Custom
Lids!**

- Durable Roto-Molded Construction
WILL NOT Crack Like Concrete!
- Lightweight Polymer is Easier to Handle & Transport
- Corrosion Resistant Stainless Steel Screws Included
- For use with Standard 18"
and 24" I.D. Corrugated Pipe
- Easy Slide-in Installation
- Optional Sand Filled

Roto Solutions

800.868.0973

Don't Waste Money On Expensive Riser Systems!

The Original "Tiger-Tail" Hose

Manufactured by Plastiflex®

Special Pricing Available exclusively through TOICO Industries. Act now to take advantage of this limited time offer.

10% Discount on all "Tiger-Tail" Hose Through August 31, 2009

TOICO Industries carries a wide selection of portable restroom parts and accessories to take care of all your needs, including toilet parts, pumps, pressure washers, hoses, valves, fittings, tank components, chemicals, dispenser systems, hand sanitizers, deodorizers and odor control products, engines, sink parts, cleaning supplies, and much much more.



1-888-935-1133

www.toico.com

ERICKSON TANK & PUMP



PORTABLE TOILET TRUCK



VACUUM TRAILER TANKS



SEPTIC PUMPER TRUCKS

Check Our Web Site
for Current Inventory!

"Tanks" for your business!

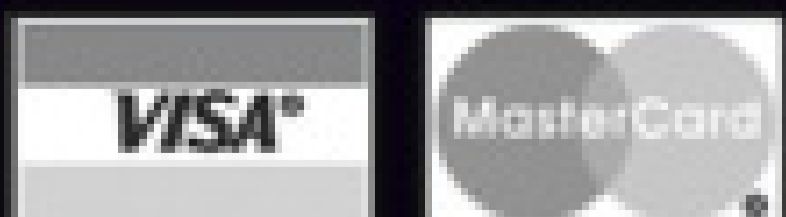

509.785.2955

WWW.ERICKSONTANK.COM

One Complete Package

promonthly.com

cleaner.com

pumper.com

mswmag.com

onsiteinstaller.com

pumpershow.com

pumpetrader.com

eq-mag.com

tpomag.com

septicyellowpages.com

sewerpages.com

COLE Publishing

1.800.257.7222 | 715.546.3346

Seasons Change - Dedication Doesn't

- **Stainless Steel**
- **Aluminum**
- **Code & Non-Code**



45 Years of Manufacturing Experience

Manufacturing

**Vacuum Trailers for the
Liquid Transportation Industry**

Parts • Repair • Complete Pumping Systems

800-589-5254

www.acrotrailer.com • 417.862.1758 • fax 417.862.8084 • 2320 North Packer Road • Springfield, Missouri 65803

**Everyone
talks about
creating a
greener
environment.**

You actually do it.

Find the tools you need to keep
your communities **green** at
www.colepublishing.com.

Publishing environmental trade magazines since 1979.

ART'S TRUCKS & EQUIPMENT

View Our Entire Inventory
Online: www.artstrucks.com

3001 West Expressway 83
McAllen, Texas 78503
956.686.2326 Fax 956.686.5179

1.800.292.7007

www.artstrucks.com

1999 GMC Sewer Rodder Truck,
Diesel Engine, Automatic Transmis-
sion, J. Deere Rear Diesel Engine,
535 Gallon Tank, FMC Pump, 123,711
Miles, Lot #2915999 - \$22,500



1999 VOLVO Combo Sewer Truck,
VOLVO-275HP Diesel Engine, Allison 3560
Automatic Trans., A/B, A/C, 55,604 Miles,
Vac-Con Sewer Cleaner, John Deere Rear
Diesel Eng., Lot #2815680 - \$65,000

2002 STERLING Combo Sewer
Cleaner Truck, CAT 3126 Diesel
Engine, Automatic Transmission,
A/B, A/C, Vac-Con Sewer Cleaner,
J. Deere Rear Diesel Engine, 44,391
Miles, Lot #2815806 - \$75,500



1998 FORD LOUISVILLE Sewer
Cleaner Truck, CAT C10 - 320HP
Diesel Engine, Automatic Transmis-
sion, A/C, A/B, 119,959 Miles, Camel
200 Unit Lot #2815815 - \$55,500

Classy Truck
of the Month

Ronnie's Septic Tank Service Inc.
Brewster, N.Y.

CLEAR COMPUTING *with* INSIGHT

Total Activity Control Street Eagle GPS

Go Green and Save!

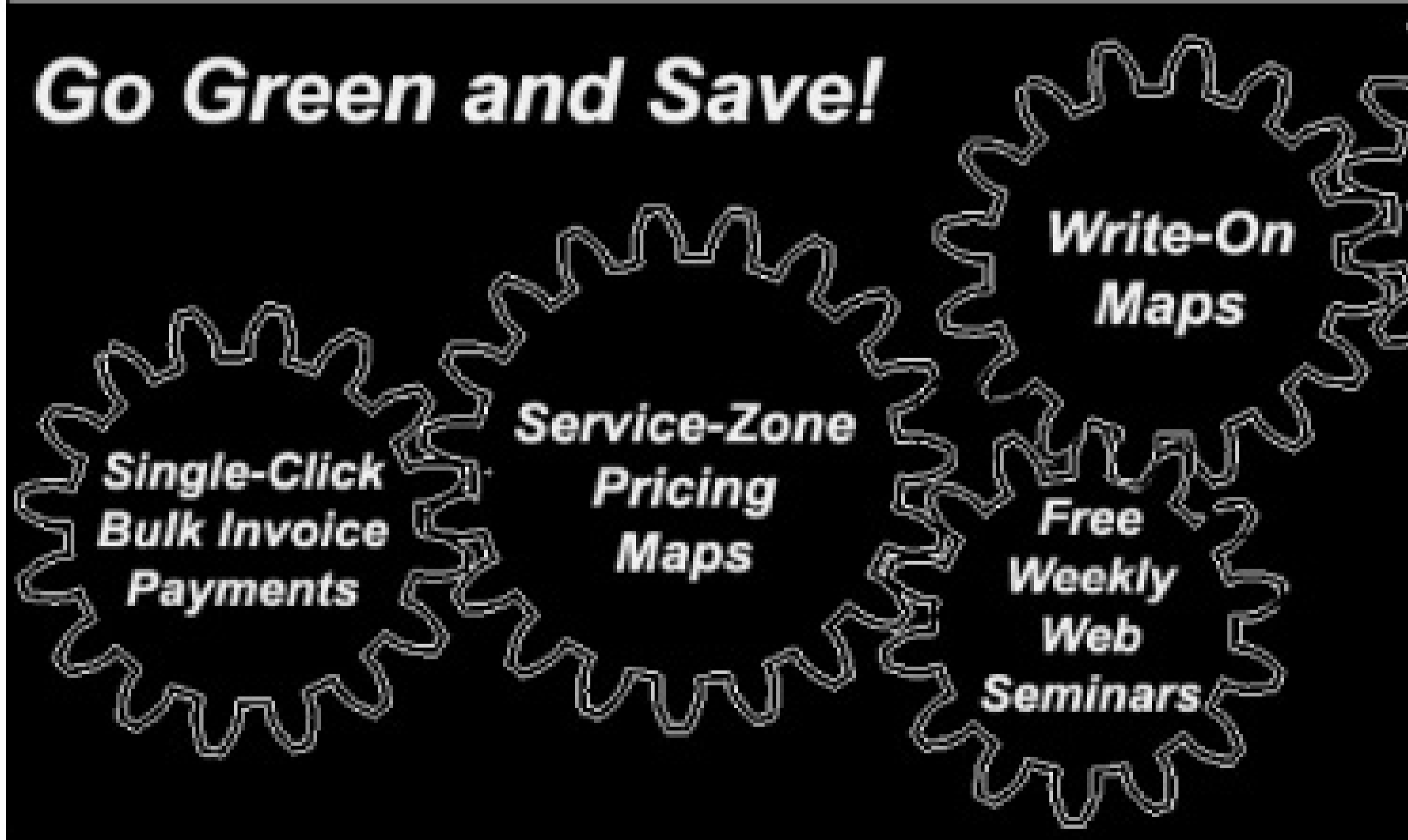

Start Saving NOW!

Microsoft
CERTIFIED
Partner

Clear Computing
(888) 332-5327
www.clearcomputing.com

- Lease or Buy
- FREE Trial

Insight USA
(301) 866-1990 x201
www.mds-inc.com

When Ronnie and Iris Daniels decided to get into the pumping business recently, they jumped in with a new rig. They ordered a 2009 Kenworth T300 with a 300-hp PX-8 engine and a 5-speed Allison automatic transmission from Cooper Kenworth in Hickory, N.C. He had the maroon and white head-turner built out by Abernethy Welding, equipped with a 2,500-gallon steel waste tank connected to a Masport HXL400 pump. The truck has heated valves, aluminum wheels, tool boxes and hose trays for light weight and good looks. The trays are lined with Rhino Liner for durability and convenience. Lettering, pinstriping and graphics were provided by Rich Alexander of Mount Kisco Sign Co. Daniels ordered the top-of-the-line full leather interior with woodgrain dash, corner windows and CD player. Daniels says his *Classy Truck* submission is in honor of the late Jim Sigmon of Cooper Kenworth, who helped him with the truck before passing away earlier this year. ■

SHOW US YOURS!

Got a truck with real WOW appeal? Show it off to Pumper readers — and to the whole world through www.pumper.com!

Send photos of your truck after it has been lettered with your company name, and please pose the owner(s) with the truck. Any industry-related truck is acceptable. Please limit your submission to one truck only.

Your submission must include your name, company name, mailing address, phone number, and details about the truck, including tank size, cab/chassis information, pump information, the company that built the truck, and any other details you consider important. In particular, tell us what features of the truck help make your work life more efficient and more profitable. E-mail your materials to editor@pumper.com or mail to Editor, Pumper, P.O. Box 220, Three Lakes WI 54562. We look forward to hearing from you!

FEBRUARY 24-27, 2010 • LOUISVILLE, KY

CELEBRATING

30

years

1981-2010



| www.pumpershow.com |

BDP Industries 3DP Belt Filter Press

The redesigned **3DP belt filter press** from **BDP Industries** offers more convenient access and easier maintenance, and produces a higher concentration of discharge solids, says Kelly Brown, director of marketing and sales.

"We started out with a clean sheet of paper and put everything we've learned about belt filter presses into the 3DP," Brown says. "It's aimed at the municipal biological sludge market and at mobile contract sludge dewaterers."

For the mobile contract dewatering market, the unit is designed to mount inside a semi trailer. With that in mind, the 3DP's independent gravity zone inlet is located at waist level for easy access and operation.

"Many belt press inlets are near

in the
SPOTLIGHT

By Ken Wysocky



Above: The 3DP mobile trailer unit's discharge point is 12 feet above the ground, enabling operators to park a dump truck underneath for easy cake removal. Left: The unit's feed box design produces uniform slurry distribution.

the roof of the trailer, which means the operator needs a ladder to get up to it," Brown explains. "With the 3DP, the inlet is right where you can see it, which makes operation much easier."

In addition, the unit features a vertical pressure zone instead of a horizontal zone. Filtrate pans under each roll keep filtrates from falling on adjacent rolls and re-wetting the cake.

"That way, you get a higher concentration of discharge solids," Brown says.

The vertical pressure zone offers another advantage: the discharge point for dewatered material is seven feet above the semi-trailer deck — which is actually about 12 feet above ground level. This provides operators with clearance to park a dump truck under the discharge point for easy cake removal, instead of using a conveyor or front-end loader, Brown notes.

The unit includes a variable-speed paddle wheel feed box that spreads slurry out along the width of the press, which promotes uniform thickness and minimizes clogging.

"Maintenance costs are lower, too, because with a more even cake, there are fewer abrasions on the roller coating and less wear on the filter-belt cloth," Brown adds.

The machine features tubular frame construction. Because tubular construction features flat surfaces with no corners or ledges, it's easier to clean. Thanks to vent holes, a hot-dip galvanized coating covers both the inside and outside of the frame, which maximizes corrosion protection. **For more information: www.bdpindustries.com or 518/527-5417.**



Pans under each vertical pressure roll keeps filtrate from falling on adjacent rolls, eliminating reabsorption and improving cake solids.

Ameri-Can Expands ADA, Value-Priced Shower Line

ADA shower trailers from Ameri-Can Engineering are available in 22 models in a variety of floor plans, sizes and luxury grades. The trailers feature a rear-mounted pod that lowers to the ground for handicapped accessibility. Ameri-Can also has developed a line of value-priced trailers, including the 810 that provides four private showers in a compact unit. Features include onboard freshwater, gray-water tank and LP on demand hot water. 574/892-5151; www.ameri-can.com.



810 Shower Trailer from Ameri-Can Engineering



ADA Shower Trailer from Ameri-Can Engineering

Bord na Mona Introduces Wastewater Reuse System

The PuraMc compact membrane graywater recycling system from Bord na Mona Environmental Products U.S. Inc. is designed to produce residential water suitable for non-potable reuse, such as toilet flushing and irrigation. The system uses ultra-filtration membranes to remove solids and pathogens from wastewater without the need for chlorination or UV treatment in the removal of BOD, nitrogen and phosphorus. 336/547-9338; www.bnm-us.com.

PortaPump from PumpBiz International



PumpBiz Introduces PortaPump

PortaPump from PumpBiz International is designed to remove standing water from golf course bunkers and fairways, flooded parking lots and sidewalks or drain water from pits that need to be excavated due to pipe breakage or root damage. Able to pump up to 2,000 gallons per hour, the one-person unit is powered by a Honda 4-stroke 35cc engine that drives a flexible shaft and impeller in the pump head. A larger unit, able to pump up to 16,800 gallons per hour, is available. 800/786-7249; www.pumpbiz.com. ■

Agitation SAVES Aggravation!

CHOICE OF 2, 4' & 6' EXTENSIONS

Guaranteed To Mix Up Septic Tanks & Grease Traps!

High speed rotation busts the crust and removes solids right off the bottom of the tank into a total liquid form

Field tested and proven to mix a residential tank in 5 minutes or less – takes approx. 15 minutes to agitate a 5000-10,000 gallon grease trap

Patent Pending

CRUST BUSTERS™

E-MAIL pete@crustbusters.com
WEB SITE www.crustbusters.com

ASK ABOUT OUR "BUSTER BRACKETS" FOR TRUCK MOUNTING

CHECK OUT OUR NEW INFORMATIONAL DVD
PUMPER.COM/VIDEO.PHP

Schmitz Brothers L.L.C.
PHONE 763.878.2296
FAX 763.878.2299

1.888.878.2296

Longhorn Tank Co.

The Solution for All of Your Pumping Needs



Call or Email Us For a Quote Today

Aluminum, Stainless, & Steel Vacuum Trailers in any Size
Bobtanks for Septic, Portable Toilets, Grease Traps, Etc.

800-422-9840

sales@longhorntank.com

PO Box 1147 Gravette, AR 72736

Fax 479-787-6935

For 30 years, V.E. Enterprises has been building liquid storage trailers and tanks for leading environmental, waste management, construction and energy service companies for a reason: customers value **experience**.

Experience alone isn't enough to stay competitive in this global economy. It takes a world-class facility, state of the art equipment and ASME certified welders to manufacture products that are the highest **quality**.

Maintaining top quality doesn't always guarantee customers will keep coming back. It takes a company that stands with its customers - listening, thinking and responding with the next breakthrough storage design - that's **innovation**. That's V.E. Enterprises.



experience • quality • innovation

*Setting the Standard For Liquid Storage
and Transports Since 1987*

800.234.2329
sales@veenterprises.com
www.veenterprises.com



Tigerflex

**Tiger™ Green/
Tiger™ Yellow/Tiger™ - SD**

- Superior EPDM compounds - longer life; more durable; superior chemical resistance.
- Superior Flexibility - 22% more flexible! Easier to handle off trucks, especially in cold weather!
- UV and weather resistant exterior.
- Specially designed abrasion-resistant helix - slides over and around objects; easier to handle and work with.
- Tiger™-SD - reinforced for both suction & pressure discharge applications.

Applications:

- Septic handling
- Liquid and dry chemical & fertilizers
- Sewer cleaning water jetting leader hose
- Construction

**Nothing Else is
TIGER™ GREEN
Ask For It By Name!**

Kuriyama of America, Inc.
360 E State Parkway | Schaumburg, IL 60173
847.755.0360 | fax: 847.885.0996
email: sales@kuriyama.com | www.kuriyama.com



IT'S A Bag Full

pumper.com

- > Classifieds
- > Truck Stop Ads
- > E-zines
- > Product Categories

THE LEADER IN PUMPER/CLEANER REELS SINCE 1933

Hannay Reels
The reel leader.

Washdown and Clean Up With Hannay Reels

Applications

- Power washing
- High pressure washing
- Vehicle and equipment washdown and clean up

Advantages

- Flexibility of mounted and portable designs
- Hose pickup and storage is quick and neat
- Tried and tested technology
- Tough reels for the toughest environments



Download or call for your FREE catalog
http://go.hannay.com/\$15 877-467-3357



CLEAR SKIES AHEAD?



If weather is less than perfect this season, JAG Mobile Solutions is ready for the worst **Mother Nature** has to offer. With a full inventory of shower and restroom trailers, we're prepared for anything. **Are you?**

Call now for more information on JAG's available **mobile showers, restrooms and disaster relief equipment.**

800-815-2557 **www.jagmobilesolutions.com**

Septic / Grease Trap & Portable Restroom Vacuum Service Tank Trucks



Sales
Service
Financing



Contact: Mark C. Langworthy
800-261-9009

e-mail: mlangwor@tanktruckservice.com
www.tanktruckservice.com

Tank Truck Service & Sales, Inc.
25150 Dequidre, Warren MI 48091



1200 to 6000 Gallon Aluminum Tanks
Most Make Chassis **IN STOCK!**



Pump! Save! Earn!

With **PRO-PUMP**

The Finest Name in Biological Products for Septic Systems, System Recovery, Odor Elimination and More...



- Septic System Treatment
- Absorption System Recovery
- Aerobic System Treatment
- Drain & Grease Traps
- Solids Reduction
- Odor Control
- Bio-remediation

Our 33rd Year!

Call Greg Toll Free at 1-800-326-7867 and ask about our Special Discounts & Free Freight!

Solving Problems, Naturally!
Ecological Laboratories INC.

TOLL FREE: 1-800-326-7867 • FAX: 516-823-3440 • EMAIL: info@propump.com

Visit our web site at: www.propump.com

By **Scottie Dayton**

NATION: Installer Academy Scheduled

The National Onsite Wastewater Recycling Association Board of Directors announced that the Installer Academy will become part of the 2010 Pumper & Cleaner Environmental Expo Feb. 24-27 in Louisville, Ky. If the board goes ahead with its 2010 Conference in St. Louis, it will occur in fall. The board is communicating with other wastewater associations about a possible joint conference.

COLORADO: Streaming Live Conference

The Colorado Professionals in Onsite Wastewater will broadcast its January 2010 Denver conference via streaming Web video to members on the western side of the state. Organizers have added certification and continuing education credits for onsite inspectors and installers to the conference training track. The board is working to set up quarterly training programs.

The association helped the Colorado Department of Health and Environment create its full-time position of onsite coordinator. That staff member, Barbara Dallemand, P.E., will plan strategies about the future of onsite regulation. The group also helped the Colorado State University Extension produce a 15-minute DVD addressing private wells and onsite systems. The video is part of the university's Private Well and Septic System Educational Package.

INDIANA: Outlandish Product Claims

The Indiana Onsite Wastewater Professional Association offers a new source for combating Internet misinformation and rumors about onsite systems. The Indiana Septic System Forum (www.septicdesign.com/forums), monitored by regulators, excavators, and design professionals, hosts discussion boards on general questions and posts regulatory documents in searchable PDF format.

MINNESOTA: Ceramic Membrane Bioreactor

A flat sheet ceramic membrane bioreactor from SJE-Rhombus is treating wastewater from 36 homes on Lake Melissa's Ravenswood Beach, Minn. This is the first treatment plant of its kind in the United States, reports the Ontario Association of Sewer Industry Services. The homes had a decentralized system, but one of two small drainfields was ponding. The technology has a 200-square-foot footprint and handles 10,000 gpd.

After the bioreactor, effluent flows through the ceramic filter, where filtration at 0.2 microns removes even pharmaceuticals and endocrine disruptors.

The ceramic filters are backflushed periodically, and the system is monitored and controlled by way of the Internet. The filters will last 20 years before replacement. The system's final effluent was so clean the failing drainfield recovered.

National Association of Wastewater Transporters

- Oct. 9-10 – Waste Treatment Symposium, Orlando, Fla.
 - Nov. 5-6 – Operation and Maintenance, San Luis Obispo, Calif.
- Call NAWT at 800/236-6298 or visit www.nawt.org. For California classes, call MaryAnne Bobrow at 530/321-2207 or e-mail maryanne@cowa.org.

Alabama

Licensing classes are the joint effort of the Alabama Onsite Wastewater Association and University of West Alabama. Courses are at the UWA Livingston campus unless stated otherwise:

- Sept. 3-4 – Continuing Education, Florence
 - Sept. 16-18 – Advanced Level I Installers
 - Oct. 1-2 – Continuing Education, Montgomery
 - Oct. 15-16 – Pumper
 - Oct. 29-30 – Continuing Education, Mobile
- Call 334/396-3434 or visit www.aowa.org.

Iowa

The Iowa Onsite Wastewater Training Center at Ankeny is offering:

- Sept. 15 – Site Evaluation and Design
- Oct. 20 – Basic 101

Call Annette Adams at 515/964-6464, option 5, ext. 6464 or visit www.iowwa.com.

Michigan

The Michigan Onsite Wastewater Training and Education Center at MSU Tollgate Center in Novi is offering these courses:

- Sept. 24-25 – Onsite Wastewater Systems Maintenance
- Oct. 7-8 – Existing Systems Evaluator Training
- Nov. 4-5 – Onsite Wastewater Systems 101

Call Barb DeLong at 517/355-4720 or visit www.egr.msu.edu/age/outreach.html.

Missouri

The Missouri Smallflows Organization is offering a two-hour Wastewater course Sept. 11 in Clinton. Call Fred Boehler at 660/885-8193 or visit www.mosmallflows.org.

New England

The New England Onsite Wastewater Training Program at the University of Rhode Island in Kingston has these workshops:

- Sept. 3 – Wastewater Treatment Basics
- Sept. 17 – Innovative and Alternative Technology Overview
- Sept. 22-23 – Inspecting Onsite Systems
- Oct. 1 – Innovative and Alternative Technology
- Oct. 8 – Bottomless Sand Filter Design and Installation
- Oct. 15 – Functional Inspections

Call 401/874-5950 or visit www.uri.edu/ce/wq. Contact David Kalen at 401/874-5950 or davidkalen@mail.uri.edu.

Aug. 6-8

Florida Onsite Wastewater Association Conference, Ocean Center, Daytona Beach. Call 407/830-4381 or www.fowaonsite.com.

Aug. 7-8

Wisconsin Liquid Waste Carriers Association Summer Convention, Potawatomi Northern Lights Casino and Hotel, Wabeno. Call 608/255-2770.

Aug. 12-14

North Carolina Septic Tank Association Outreach Symposium, Greenville Convention Center, Greenville. Call Monica Rhea at 704/739-5849 or visit www.ncsta.net.

Aug. 28-29

Georgia Onsite Wastewater Association Conference, Marietta Conference Center, Marietta. Call 678/646-0379 or visit www.onsitewastewater.org.

Oct. 20-21

Delaware Onsite Wastewater Recycling Association Technical Conference, Dover Downs Hotel and Casino, Dover. Call Mike Cotten at 302/226-2844 or visit www.dowra.org.

Oct. 22-23

Ontario Association of Sewage Industry Services Rural Wastewater Treatment Expo, Hamilton. Call 877/202-0082 or visit www.oasisontario.on.ca.

North Carolina

North Carolina Soils and On-Site Wastewater Training Academy has the following courses at Raleigh unless stated otherwise:

- Sept. 15 – Subsurface Wastewater System Operator Training, Bolivia
- Sept. 23-25 – Designing Wastewater Irrigation Systems
- Oct. 6 – Subsurface Wastewater System Operator Training, Plymouth

Call Joni Tanner at 919/513-1678 or visit www.soil.ncsu.edu/training.

The North Carolina Septic Tank Association has these courses:

- Oct. 8-9 – Installer/Inspector, New Bern
- Oct. 14-15 – Installer Inspector, Greensboro
- Oct. 16 – Pumper, Greensboro
- Nov. 12-13 – Installer/Inspector, Hickory

Call Connie Stephens at 336/416-6394 or visit www.ncsta.net.

Pennsylvania

The Pennsylvania Septage Management Association is offering an Onsite Inspection course Sept. 16-17 in Williamsport. Call 717/763-7762 or visit www.pasma.net.

Utah

The Utah On-Site Wastewater Treatment Training Program is offering Onsite Wastewater Treatment Certification Workshops:

- Sept. 22-23 – Level 1 Certification, Heber City
- Sept. 24, Level 1 Certification Renewal, Heber City
- Sept. 25 – Level 2 Certification Renewal, Heber City
- Oct. 14-15 – Level 2 Certification, Logan

- Oct. 20-22 – Level 3 Certification, Logan
- Oct. 29 – Level 3 Certification Renewal, Logan

Call Carmell Burns at 435/797-3174 or visit

<http://uwrl.usu.edu/partnerships/training/classes.html>.

Virginia

The following courses by the Virginia Center for Onsite Wastewater Training are at Blackstone:

- Sept. 10 -11 – Pumps and Controls
- Sept. 15-16 – Onsite Sewage Regulations
- Sept. 22-23 – Onsite Sewage Regulations
- Sept. 28-Oct. 2 – Design Camp I
- Oct. 19-23 – Soils
- Oct. 27-28 – Onsite Sewage Regulations
- Oct. 28-29 – Understanding Water Movement in Soil

For VCOWT classes, contact Lydia Cox at 434/292-3101 or visit www.southside.edu.

Pumper invites state associations to post notices and news items in this column. Send contributions to editor@pumper.com. ■

WWW.ROOTERMAN.COM



Franchises available with low, flat fee
New concept. Call 1-800-700-8062.

FRANCHISE PACKAGE \$7,950.

Sewer Camera

\$399
Free Freight



Jetter Package

4.0 GPM 4000 PSI



\$1,499
Free Freight

Sewer Snake

\$1,499
Free Freight



COMPLETE DETAILS AT
www.AmazingMachinery.com
1-800-504-7435

FIND LEAKS and Sources of Odor

Quick • Inexpensive • Easy
with the

Superior® 5E



Electric Smoker

Using Superior® Classic Smoke

1-800-945-TEST

www.SuperiorSignal.com

Mobile Dewatering Service



**Municipal & Industrial Sludge
Digesters, Lagoons,
Ponds, etc.**

- Double Belt Filter Press
- Up to 25% Drier Cake
- Professionally Staffed
- US & Canada

Fluid Technology, Inc.

P.O. Box 937, Oxford, OH 45056

Phone: 513-981-7808

E-mail: sales@fluidtechinc.net

Web site: www.fluidtechinc.net

Simple Solutions
DISTRIBUTING LLC

MAKERS OF

Wolverine Brand™

DOOR CONTROL PRODUCTS

\$40 ea

Case Qty 6

Free Shipping

lower 48



**Wolverine Brand Vent Filters
Stop The Stink-GUARANTEED!**



In New Jersey
973-846-7817

Outside New Jersey
866-667-8465

www.IndustrialOdorControl.com
www.StopSepticOdor.com



**CONFINED
SPACE
ENTRY
PACKAGE
ONLY \$2,995**



**The best package on the
market includes:**

- 4-Gas Air Monitor
(3 Year Sensor Warranty)
- 7' Tripod
- 3-Way Fall Protection
- Work Winch
- Full Body Harness



Add a **Blower** with 15' of duct for only \$300!
Add a 5 Minute **Escape Respirator** for only \$500.

Ask About Our

- CUES Camera Systems
- GapVax Combination Trucks
- Harben Jetters
- Vac Replacement Parts
- Nozzles & Hoses
- Blowers & Ventilators
- Magnetic Lid Lifters
- Aluminum Folding Ladders
- Repairs & Service

MTECH 800.362.0240

www.mtechcompany.com

PADLOCKS

Economy
Portable Toilet
Padlocks PUMP

Corrosion-
Proof, Brass
Padlocks w/
Stainless
Steel Shackle

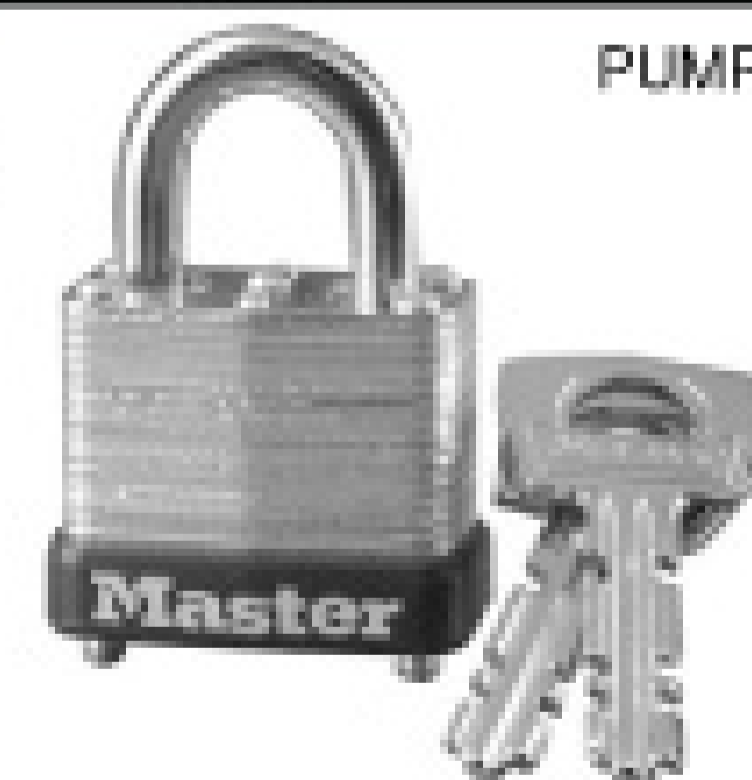

Master® American® Sesamee®
Cost-Effective Generics Too
Key Number Matching: No Charge!
Any Quantity Speedy Delivery

VIEW & ORDER ONLINE
OR CALL FOR MORE INFO

LockMasters USA Inc
1-800-461-0620

www.lockmastersusa.com

JOIN THE DISCUSSION!

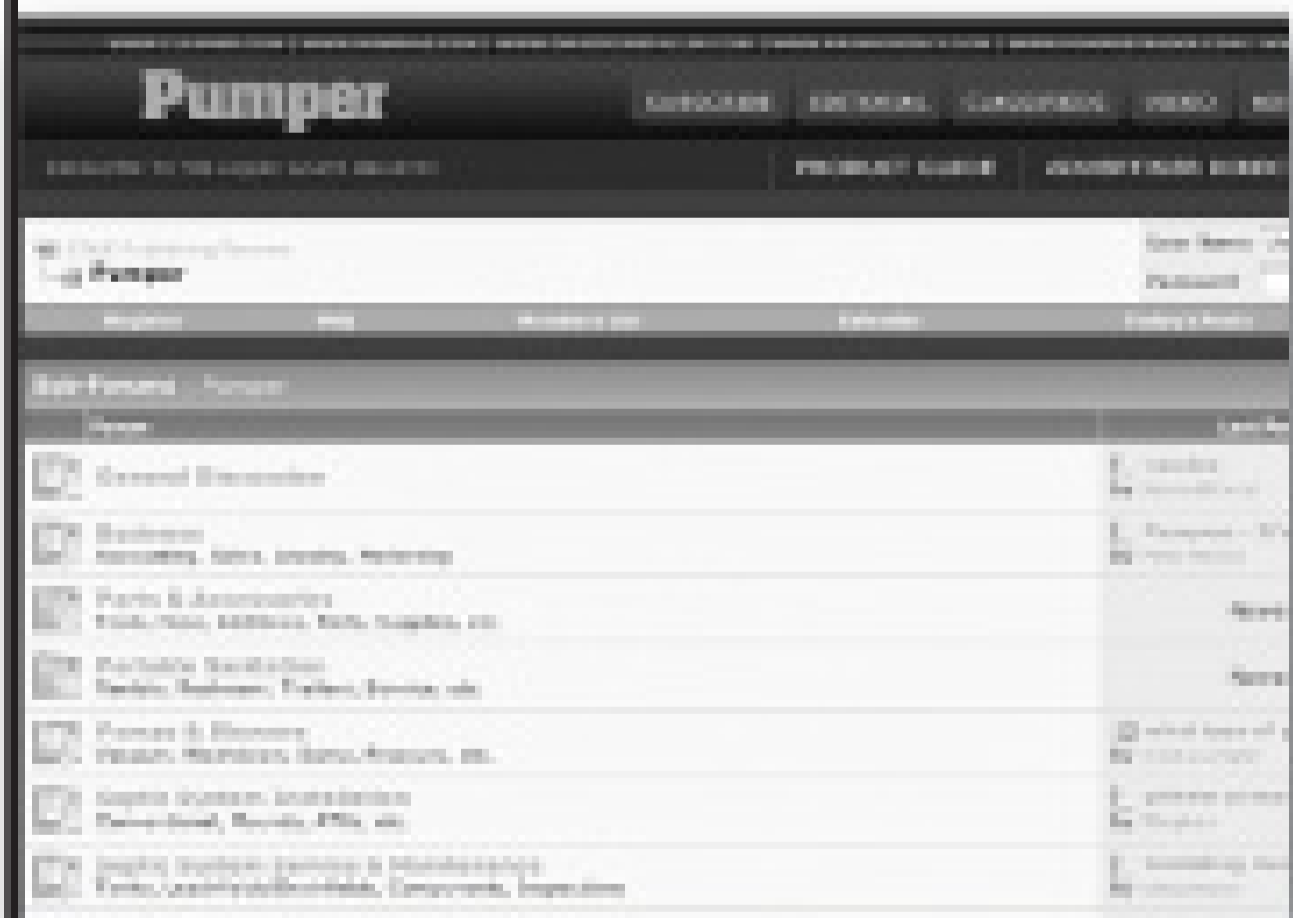

Pumper Discussion Forum is
an online based tool for industry
professionals to swap informa-
tion and ideas on topics related
to the liquid waste industry.

Sign up today at
www.pumper.com

ONSITE installer



For those who design, manufacture,
engineer and install septic systems
and other onsite wastewater
treatment systems

Subscribe today!

IT'S FREE.

onsiteinstaller.com

SOFTWARE FOR YOUR INDUSTRY

Summit Rental Profit Builder™ & Summit Service Profit Builder™

Business efficiency... NOW more than ever!

- | | |
|-----------------------|------------------|
| Rentals | Services |
| Automatic Billing | Reminder Cards |
| Pro-Rations | Diagrams, Maps |
| Sales Tax & VAT | Work Orders |
| Routing, Maps | Job History |
| Automatic Credit | Commissions |
| Card Processing | Dispatching |
| Receivables | Receivables |
| Inventory Control | Auto Repeat |
| Exclusive ERIT™ | Automatic Credit |
| Proof of Service Unit | Card Processing |
| Scanning | Inventory Parts |
| QuickBooks® Link | QuickBooks® Link |
- ...and much more...

Easiest to use!
We can transfer your data!
Over 27 years experience!

Demos on line...or call for a Demo DVD or a personal guided tour

Summit
Ritam Technologies, LP
Sales USA/Can 800-662-8471
Sales Int'l: 208-629-4462
Email info@ritam.com
Web www.ritam.com

Aluminum Vacuum Tanks

ALUMATANK

progresstank.com

PORTAVAC

Septic & Restroom Service

DISCOUNT ALUMINUM

SHEET, COIL, PLATE

3003/5052/
5454/5083/5086
AND MORE

20 MILLION POUND INVENTORY

ARE YOU PAYING TOO MUCH?

1-888-540-0066
ASK FOR JAYSON

FAX:
440-286-2229

E-MAIL:
captaluminum@msn.com

T&T TOOLS **T&T Tools**
800-521-6893
800-521-3260 FAX
E-mail sales@tandttools.com • www.tandttools.com



Mighty Probe™	Handy Hook™
Sludge Hoe™ (insulated)	Water Probe
Sludge Spud™	Curved Spud™
Manhole Hook	Top Popper™
Tommy Hook™	Ground Buster™
Striking Head™	Smart Stick™ (standard)

www.tandttools.com

WATER JETS FOR RENT



- Units from 4,000 to 40,000 psi, including convertibles
- 60-600 hp, diesel or electric
- Rent, buy or lease
- Branches in MI, TX, NJ, CA, LA

NLB Corp. 1-877-NLB-7996
www.nlbcorp.com

Have you seen the **Pumper E-Zine?**

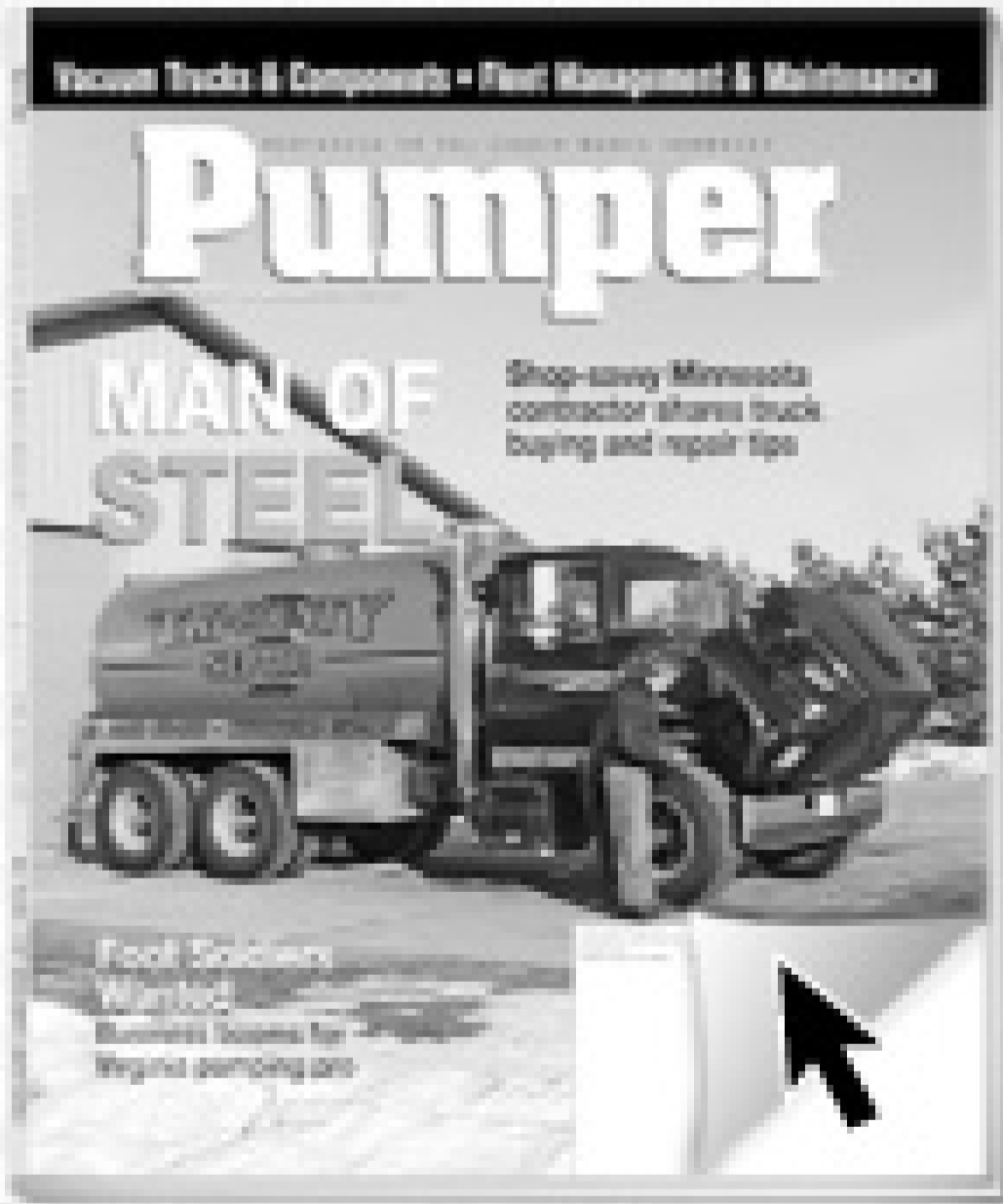

Go to **pumper.com** to view the e-zine.

Waterblaster Rentals
Houston, Texas



Boatman Industries
1K to 50K psi
60 hp to 1000 hp
Waterblasters & Accessories
Used Equipment Sales
713-641-6006
www.boatmanind.com

ARE YOU TIRED OF RAKING AND SHOVELING?



You should try a **HALL'S GRADE BLADE** on your backhoe or excavator.

- 4 sizes available, 4' to 10', for excavators
- 5 different sizes for rubber tire backhoes and mini-excavators

If you would like to know more, call us toll-free at **1-888-372-8933**.
Hall's Grade Blade, Inc. • www.gradeblade.com

One Complete Package

pumper.com	eq-mag.com
promonthly.com	pumpershow.com
mwmag.com	pumpertreder.com
cleaner.com	septicyellowpages.com
onsiteinstaller.com	sewerpages.com

COLE Publishing
1.800.257.7222 • 715.546.3346

PUMPER & CLEANER ENVIRONMENTAL EXPO INTERNATIONAL

go to **www.pumpershow.com**

FEB. 24-27

EASILY MOVE RESTROOMS

- ✓ Aluminum Frame
- ✓ Ships UPS
- ✓ Carry ADA's
- ✓ Models starting at \$380



Available with 2, 4, 6 or even 8 wheels and your choice of air or solid foam tires.

Super Mongo Mover®

DA
Deal Assoc. Inc.
www.dealassoc.com
866.599.3325



ASHLAND PolyTraps
Grease, Oil, Hair and Lint Traps and Interceptors

- NO Rust or Corrosion
- Lightweight
- Very Cost Effective
- Sizes up to 560 Gallons
- Made in the U.S.A.!

LIFETIME WARRANTY!

Certified by U.P.C., IAPMO and P.D.I.

800-541-8004
PolyTraps@Amplex.net
www.ashlandpolytrap.com

Pumper

see photos in COLOR at www.pumper.com

TRUCK STOP



August



2001 Sterling: 54,000# GVW, Cat 3126B 300 hp, 8-spd., 3500 gal. Transway TST500, Transway pump, heated valves.\$46,900
Call Judge Coleman 516-398-5638
or Email: cwjudge@aol.com P8



1993 International 4900 DT 466: 250 hp, 33,000 GVW, 6+1 trans, new motor 80,000 miles, 2,350 gallon tank, Jurop R260 pump, cab repainted, new tires. Great starter truck.\$35,000
770-898-3761 - Georgia P8



2003 VacCon V390SH: 9-yd. debris body, 3-stage vacuum compressor, hydrostatic blower drive, telescopic boom, articulating hose reel, 2003 Sterling chassis, diesel, automatic. Extremely low hours and miles. (Stk. 1596)
Call Joe 312-208-6373 P8



2009 GMC C5500 4x4 Cab & Chassis: 330 hp diesel, Allison auto., 108" CA, ready to mount a tank or flatbed.
Contact Lance Ellis 706-831-6458
and visit: www.fcctrucks.com P8



1994 Ford L9000: 33,000 GVW, 260 hp, L10 Cummins, 8-spd. Fuller, 2500 gal. tank unit built in 2000, 200 cfm Masport installed in 2005.\$24,990
Call Judge Coleman 516-398-5638
or Email: cwjudge@aol.com P8



2006 Peterbilt 379: C-15 Cat 475 hp, 13-spd., new 4000 gal. U.S. tank, new Jurop LC420 with all new accessories. Double framed, aluminum rims, beautiful show truck!! ..\$86,000
www.nationaltruckcenter.com
Office: 305-691-8407
Michael Vera: 786-554-0892
George Gonzalez: 954-558-0816 P8



1995 International: 4000 gallon S/S Progress tank, 1500 rpm Wittig pump. Financing available\$45,000
956-726-9999 CP8



1989 Chevy Kodiak: 2500 gal. Boyd tank, GM V8 8.2 engine, 225 hp, 5-spd. split trans., diesel, 209,650 miles, air brakes, power steering.\$13,000
919-696-4510 P8



2004 International/Maxvax 1400 Hydrovac: HT530 engine, Fuller RTO trans., 12-yd. body, 1300 gal. tank, 980000 BTU burner, 2500 psi @ 18 gpm pump, 3000 cfm blower, 22000 miles, 7484 hrs.\$185,000
Matt 330-270-0700 x108 P8



1995 Mack CH613: E7, 350, spl. 10, 4500 gal., full DOT door, 300 water, jetter 12 gpm, 2,000 psi, 700 cfm, Demag, full tire tread.\$59,750
727-576-1111 P8



1990 International 4900: 7-spd, DT 466, 178,700 miles with 1992 7-ton Delzotto Hydra-Brute with 20' bed.\$33,500
De Pere, WI
920-336-1551 P9



2001 Volvo EC-210LR Long Reach Hydraulic Excavator: Approx. 53' reach, 6 cyl. Cummins engine, A/C, heater, radio, ditching bucket included. Good condition. Ready to work.\$72,500
863-956-0315 CP8



2005 New Holland DC-95 Dozer: Cab, A/C, heater, radio, hydrostatic trans., wide track, long track, 6-way blade, rear mounted hitch, front steps, front grab handles. Excellent condition.\$64,500
863-956-0315 CP8



2000 International 8100: 10-spd., Jurop R260 vac pump, 3500 gal. tank, 6' discharge, 2-4" inlets, sight glasses.\$30,000 OBO
863-581-4009 P8



1996 Ford L-7000 w/Aqua-Tech SJ-1500: 5.9 Cummins, 5-speed, 33,000 GVW, air conditioning, former city truck, 88,857 miles.~~\$24,900~~ New Price \$19,900
814-696-4343 - Hollidaysburg, PA P8



1998 Vactor 2110 IHC Chassis: 230 hp Allison trans., 1000 gal. water, single-stage fan, 60 gpm @ 2000, telescoping/rotating reel, rebuilt machine.\$79,500
405-495-5110 P8

Pumper

see photos in COLOR at www.pumper.com

TRUCK STOP



August



2006 Volvo VHD64 w/Gapvax HV56 Industrial Vacuum Loader: 465 hp, 10-spd., hydrostatic drive, Hibon 8702 blower, 6 cyclones + 46 filter bag house, 1200 gal. water tank, 17 yd. debris tank, Uraca water pump (11,600 psi), 22,391 orig. mi., 1,700 blower hrs. Warranty.....\$217,500
Daryl @ Four Way 717-354-3199
New Holland, PA P8



2008 Vactor HXX: 12-yd. body, 1300 gal. water capacity, variable pressure system, 400,000 BTU water heater, dual 38' fans, 2008 International 7600 6x4, Cat 380 hp engine, extremely low hrs. and miles. (Stk 1479) \$275,000 OBO
Call Joe 312-208-6373 P8



(2) 2006 International 7600/HiVac Body: 27' blower, 17-yard bed, Cummins engine, 10-speed\$145,000
Eddie @ 205-837-5702 P8



2005 Peterbilt 330 ENG: Automatic, 48,000 miles, 1200 Fruitland pump, 2500 gal. steel tank, 2200 gal. waste, 300 gal. fresh, jetter w/200' hose, tank hoist, full rear opening door.....\$92,000
715-874-5274 P8



2002 Freightliner FLD112: 410 hp Cat C12, 10-spd. Fuller, PS/AC, air ride, 395K miles, NEW 3500 gal. carbon steel tank primary/secondary shut-offs, top & rear man-way, sight glasses, hose trays, 3" inlet, 4" outlet with lever valves and camlocks. New National Vacuum 367 Challenger pump, PTO and gearbox driven\$58,925 + FET
877-296-2555 P8



2004 Sterling LT9501/Vactor 2122 HXX HydroExcavators: Several available. Cat C12 engines, Eaton Fuller trans., low miles & hours, pendant controls.\$179,000
Matt 330-270-0700 x108 P8



2008 5th Wheel Tanker: 1750 gallon Honda HXL75V, 24 hp, perfect unit.
\$23,900
916-454-2000 P8



2008 Guzzler CL Model XXS4118TC: 28', 5300 cfm Hibon blower, 18 cu. yd. on 2007 IN 7600 chassis w/Cat C13 380 hp, 10-spd. man., chassis miles 8906, chassis hrs. 539, chassis trip hrs. 193.3, Vac system hrs. 186. LIKE NEW.....\$175,000 OBO
1-888-635-9854, 812-423-6616 CMP8



1999 T-300 Roll Off: VERY CLEAN, 60K miles, Cat 3126, 6-spd., 30K lbs. Rudco lift. Trash and concrete boxes available.
\$37,000
916-454-2000 P8



1997 International: DT466 engine, auto. trans., 2002 model tank, 1000 gal. waste, 250 fresh, porta-pot rack. This is a local trade and is in excellent working condition. \$12,900. We have other pot trucks as well.
877-898-5104
www.hullstruckbodies.com P8



1995 International DT466: 2300 gal. tank with a water-cooled Jurop pump. Used daily, good start-up truck or portable toilet truck.Priced to sell \$20,000
715-234-7767 P8



2003 Freightliner FLD-120: 410 hp Cat C-12, Amthor 4000 gal. alum. Hazmat DOT 407/412 cert. tank, Jurop R260 pump, Fuller 13-spd. \$72,000. Many other trucks available from 850-4500 gal. tank trucks.
Jeremy 720-254-6176
www.pumpertrucksales.com P8



2000 GMC: Rebuilt Cat engine last year, just replaced lifters and water pump, vac pump just rebuilt, 1500 gal. steel tank new in 2006. Truck works every day.
\$25,000 OR REASONABLE OFFER
Clayton @ 903-839-3942 P8



1995 Vactor 2110: Two-stage fan system, 80 gpm @ 2500 psi water pump, telescopic rotating reel, 8' telescopic boom, 1996 IH chassis, automatic. (Stk. 1589)
Call Joe 312-208-6373 P8



1999 International 4900: AC, air brakes, Keith Huber body, 1500 gallon waste, 200 gallon water.\$25,000
225-261-1015 P8



2004 Kenworth T-300: VERY CLEAN, Cat 3126, 2300/200 split tank, Allison trans., jetter, 6" discharge, 2-4" 1-2" inlets.
\$58,500
916-454-2000 P8

Pumper

see photos in COLOR at www.pumper.com

TRUCK STOP



August



2007 Sterling LT 9500 Tandem Axle Vacuum Truck: 3,360 gal. vac tank, Masport pump. Low miles and EXCELLENT condition.
Ron at 1-888-867-9507 P8



Vac-Con Model MV-311 THA: Municipally owned & maint., Ford auto trans. chassis, tires 95%, new hyd. driven 3-stage blower, recent rebuild on water pump, spring loaded washdown gun & hose reel, arrow brd., strobes, behind cab toolbox, 94,407 miles, 4,541 hrs.\$44,000 OBO
Pat's Pump & Blower - 800-359-7867 P8



1989 Ford (Vactor 2045) 1020 Holmes: 16', 4500 cfm blower, safetied and ready to work.\$18,000 OBO
Call Rob 519-384-3416
or email hdind@mnsi.net P8



2001 Supersucker: Freightliner FL112 chassis, Cat C-10 engine, 27' blower, Cotta transfer case.\$95,000
Call 1-888-739-0838 P8



1989 Mack (Vactor 2045) 1020 Holmes: 16', 4500 cfm blower, stainless steel lined, safetied and ready to work.\$18,000 OBO
Call Rob 519-384-3416
or email hdind@mnsi.net P8



2003 Ford 550: Satellite tank, auto, 7.0 diesel, 650W, 350F, 2-unit carrier, 210,000, washdown unit. Great running truck.\$19,500 OBO
315-247-0582 P9



1999 Volvo EC-140 Hydraulic Excavator: Cab, A/C, heater, radio, articulated knuckle and ditching bucket included.\$40,500
 Hyd. brush cutter attachment\$6,500
 Digging bucket attachment\$2,800
863-956-0315 P8



Purchased New 05/2007 Pre-Emission Kenworth T-800: C15 475 Acert. 475 hp, Fuller 10-spd., Concept 2000/5300 gal. alum. tank, 2 compartments. (5000 waste/ 300 fresh), 3 full-size anti-surge internal baffles. Jetter sys. w/300' hose\$160,000
570-829-3231 P8M



2001 Peterbilt 357: Cat engine, 8LL, 4000 gallon steel tank. Coming soon.
27th Trucks Inc., Miami, FL
305-835-9030 P8



1999 Mack CH613: E7, 427, 13 spd., 4500 gal., full DOT door, 300 water, jetter 12 gpm, 2,000 psi, 700 cfm, Demag, full tire tread.\$69,750
727-576-1111 P8



Used 2003 Satellite MD 950 Tank: Excellent condition, includes work lights, toolboxes, fresh water pump, 2-toilet carrying rack and Conde 6SS vacuum pump.\$9,995 OBO
231-924-8994 P8

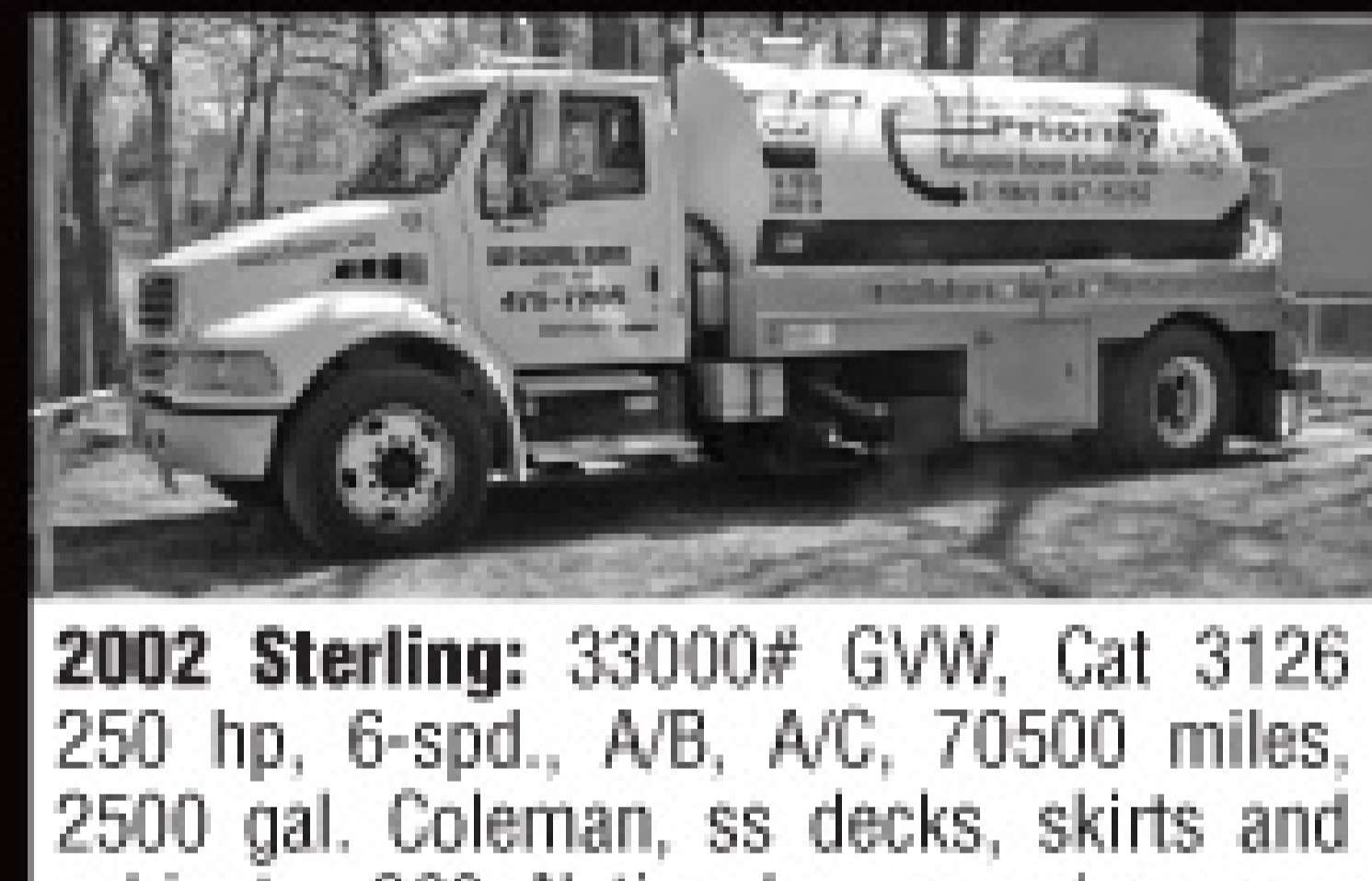

2002 Sterling: 33000# GVW, Cat 3126 250 hp, 6-spd., A/B, A/C, 70500 miles, 2500 gal. Coleman, ss decks, skirts and cabinets, 360 National vacuum/pressure pump powered by power clutch pto, heated valves. Available in Aug.\$39,990
Call Judge @ 516-398-5638;
or Email: cwjudge@aol.com P8



1992 Topkick w/1600 Gal. Tank: All new hose trays, lights, primary, secondary, valves, paint, etc.\$22,500
 Also have several other trucks for sale from 1000 gal.-4000 gal.
Jerry @ 918-381-9072 P9



2001 GMC w/Boss Pipehunter Jetter: 3/4' line w/rotating hose reel, 500 gallon tank, 80 hp aux. engine.\$31,500
 Add \$4,500 for new paint.
405-495-5110 P8



2002 Mack CHs: 10-speed, 2500 carbon steel tank. 10 available to your specs.
27th Trucks Inc., Miami, FL
305-835-9030 P8

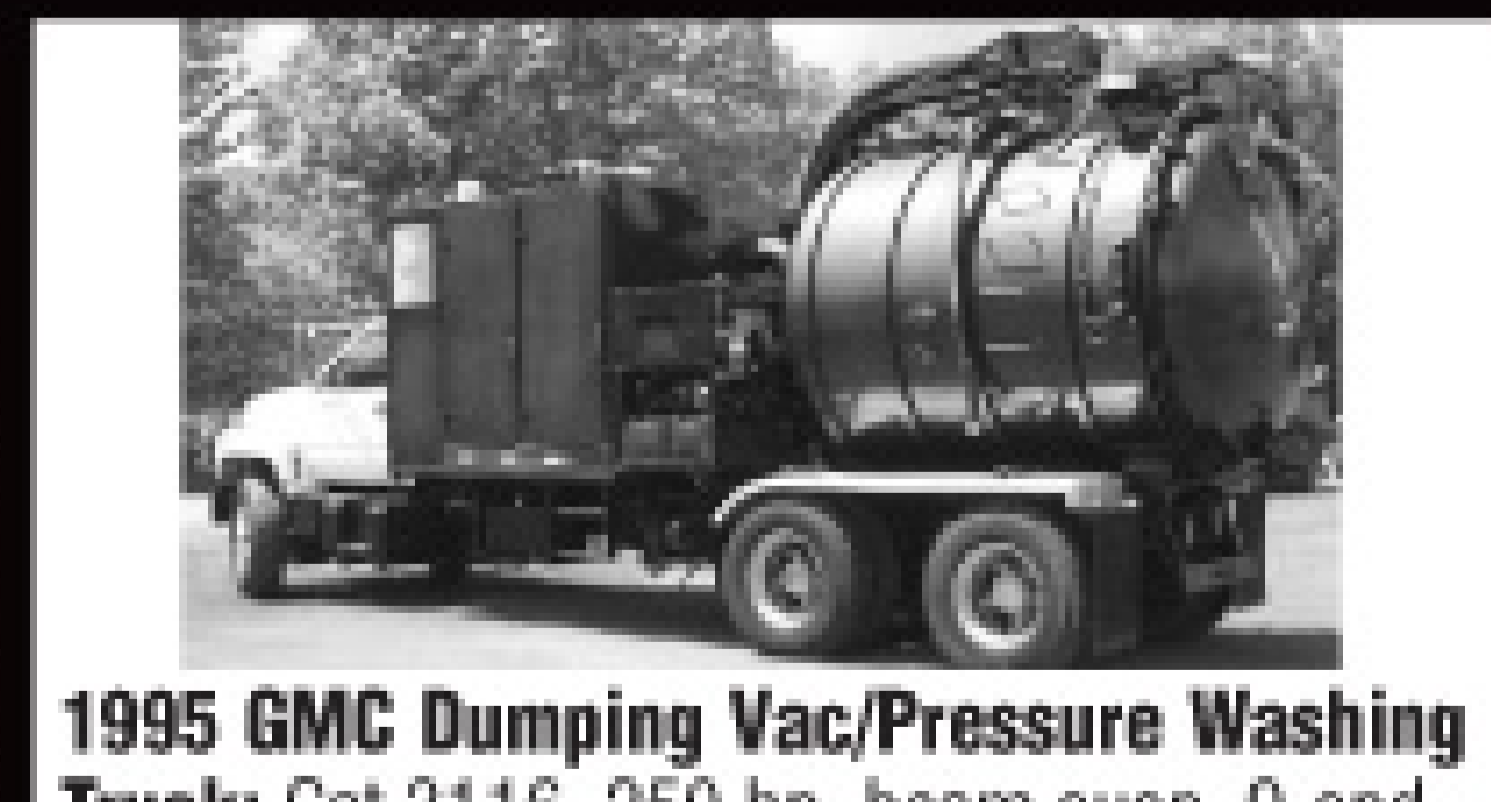

1995 GMC Dumping Vac/Pressure Washing Truck: Cat 3116, 250 hp, beam susp, 9-spd., air brakes, locking diff., 16K/40K axles, dumping vac tank, 22.5 tires, Nash vac unit driven by Cummins dsl., Supra Hot pressure wash sys. w/1,545 hrs., 4' outlet or full open rear discharge.\$29,500
715-546-2680 P8M

Pumper

see photos in COLOR at www.pumper.com

TRUCK STOP



August



Shower and Restroom Trailers: Platinum and Gold Series, new and used available. Each with separate men and women sides.
CCI/Brian Touey 805-896-3777 PBM



2005 Sterling 9500/SuperSucker MudDog: Cat C13 engine, 10-yr. body, 880000 BTU burner, 3000 psi @ 14 gpm pump, 1021DV Dresser Roots blower, 28760 miles, 2264 hours.\$195,000
Matt 330-270-0700 x108 P8



1990 Ford L8000: 1999 2300 gal. Imperial tank, rebuilt 360 Challenger pump, excellent rubber, heated valves.....\$20,000 OBO
585-229-2504 P8



2003 Mack CX-613 Vision: E-7 427 hp, Jake brake, 10-spd., new 5000 gal. US tank, new Jurop LC420 pump, with all new accessories, 20K tag axle, new paint.
Priced to Sell \$78,500
www.nationaltruckcenter.com
Office: 305-691-8407
Michael Vera: 786-554-0892
George Gonzalez: 954-558-0816 P8



2000 Mack CH-613: E-7 330 hp, 10-spd., 200K original miles, new 4000 gal. U.S. tank, new Jurop LC420 liquid-cooled pump. All accessories new. Double-framed, new paint. Call for more details!\$59,000
www.nationaltruckcenter.com
Office: 305-691-8407
Michael Vera: 786-554-0892
George Gonzalez: 954-558-0816 P8



1993 Vactor 2103: Rear decant, rear mounted arrow board, extendable boom, 500 gallon water capacity, 30 gpm @ 3000 psi water pump, 1993 Ford chassis, 175 hp engine, 5-spd. manual trans., low hrs. and miles, ex-municipal truck. (Stk. 1590)
Call Joe 312-208-6373 P8



2006 Ford F750: 5-spd., 26K lb. GVW, 2006 Progress portable toilet service unit, 2000 gal. alum. tank, 2-comp. 1500 gal. for water or premix, 1 1500 gal. for waste/debris, Masport pump, 3' suction hose.\$59,500
Opdyke Truck Sales 800-520-4704 PBM



1994 Ford LN 8000: Cummins motor, runs great, needs some work.....\$18,000 OBO
631-757-1188 P8



2003 Ford 550: Satellite 650 waste, 350 fresh, auto, diesel, 6.0, 168,000 miles, runs excellent, new injectors, new paint job. Very sharp.Priced to sell: \$20,000 OBO
315-247-0582 P9



1994 IHC: 6+1 spd., newly rebuilt DT466 less than 1000 miles, A/C, new rubber, new 2006 tank 2250/250/75, universal portables or sewer, Moro AC4 pump, pressure washer, poly liner, too much to list.\$44,000
Call Troy @ 1-800-498-3000 P8



1990 Freightliner FLD-120: 4000 gal. steel Abernethy tank, Cat 3406 diesel engine, redone 9/08. NVE Challenger 460 pump, 519 cfm, housed in toolbox. Great truck.\$25,000
919-696-4510
Raleigh/Durham, NC P8



**1996 International Vactor 1645 16\"/>
 Industrial Loader:** L10 Cummins, 8' top load with swing out boom. Excellent condition.\$55,000
Kevin 563-388-9100 CP8



2000 Sterling: C-12 Cat engine, 10-spd., AC, cruise, new 2500 gal. tank and Jurop R260 vac pump, new paint and all accessories. Nice, strong truck.\$39,000
877-898-5104
www.hullstruckbodies.com P8



1985 International S2500: 18 FRT, 44R, 7LL, 300 Cummins, R260 pump 2008, 3880 T-Line tank 2004, new tires 2009, truck runs daily. VERY GOOD condition.Price Reduced to \$20,500
715-745-2006
tcpumpers@frontiernet.net P8



350 Used Poly and Satellite Portable Toilets For Sale in Utah: Volume discounts available.\$225 each
Ryan @ 801-430-7287 P8



2005 Freightliner M2: 6-spd., 2500 gal. carbon steel tank, new pump, new paint job.
27th Trucks Inc., Miami, FL
305-835-9030 P8

Pumper[®] see photos in COLOR at www.pumper.com

TRUCK STOP



August



1989 Ford L-9000 Dumping Vac Truck: Cat 3406 B, 400 hp, 411,474 miles, 8LL, FT&M vac unit, 3,200 gal. steel dumping tank, Hendrickson RS susp., 20K/44K axles, lockers, 22.5 tires, spoke wheels, pintle hitch.\$19,500
715-546-2680 PBM



2004 Kenworth: 385 hp Cat engine, 10-spd. Jake, AC, cruise, air-ride, new 3500 gal. tank and Masport 400 vac pump, new paint and all accessories. This truck is absolutely beautiful.\$67,000
877-898-5104
www.hullstruckbodies.com P8



1998 Vactor 2110J on Freightliner: 80 @ 2500 w/1000 gal. capacity, 8' telescopic boom, auto wind., telescopic rotating reel. Will be rebuilt per Vactor specs. \$125,500
405-495-5110 P8



2006 Safevacs - Five (5) To Choose From: Sterling LT9511 chassis, MBE 460 engines, 27" Wispair blowers, OMSI transfer cases.Special Price \$149,950 Each
Call 1-888-739-0838 P8



1999 Ford F-450: 850 gal. Satellite tank, 2-toilet rack, Conde Super 6 pump, 4WD. Call for more pics and questions. \$16,000
Jeremy @ 720-254-6176
www.pumpertrucksales.com P8



2001 Custom Homemade 24' VIP Restroom Trailer: 1000 gallon built-in HT, womens 4 stalls, 2 sinks. Mens 1 stall, 3 urinals, 1 sink. Both sides A/C & heat, sky lights, all porcelain fixtures, laminate hard wood floors. 5 Star Restroom Facility.
715-723-3449 P8



2003 International 4300: 211K miles, automatic, 1100 fresh, 400 waste, Masport pump, engine overhaul 165K, king pins and brakes 212K, new radiator, tires 80%.\$32,500
John Biles 615-477-4089 P8

THIS SPACE CAN BE YOURS!

Just go to

www.pumper.com

or www.pumpertrader.com

and fill in the online form.

TRUCK STOP

See photos in **COLOR** at www.pumper.com, www.pumpertrader.com, www.cleaner.com, www.mswmag.com

Pumper/Pumper Trader

Cleaner



Advertising

BE ONLINE & IN **CLEANER, PUMPER & PUMPER TRADER** or **MUNICIPAL SEWER & WATER FOR ONLY \$125!**

Please print ad legibly with correct punctuation and PHONE NUMBER. Don't forget to send photo!

RATE \$125 PER AD, PER MONTH, PER PUBLICATION WITH A 30 WORD MAXIMUM – **PLEASE NOTE:** You can only advertise **ONE TRUCK** for sale per ad.

DEADLINES **CLEANER: 1ST OF THE MONTH • MSW: 1ST OF THE MONTH • PUMPER: 10TH OF THE MONTH** – For example: July 10th would be the deadline for August Pumper.

ADVANCE PAYMENT **NO BILLING FOR TRUCK STOP ADS.** Payment must be received in **ADVANCE** before publishing in Cleaner, Pumper or MSW.

Enclosed is \$ _____ for _____ ad(s) to run _____ month(s) in
 CLEANER **MSW** **PUMPER/PUMPER TRADER** **ALL PUBLICATIONS (TRIPLE DOLLAR AMOUNT)**

Company Name _____

Address _____ Phone _____

City _____ State _____ Zip _____

PLEASE FILL OUT CREDIT CARD INFORMATION COMPLETELY:

CREDIT CARD NO. _____ V-CODE _____ EXP. DATE _____

CARDHOLDER NAME _____ PHONE _____

• **MAIL** this completed form with payment and photo to: COLE Publishing Inc., P.O. Box 220, Three Lakes, WI 54562 (Make check/money order payable to: COLE Publishing Inc.)

• **ONLINE** ad form at: www.pumper.com, www.pumpertrader.com, www.cleaner.com, www.mswmag.com

• **FAX** this completed form to: **715.546.3786** and **E-MAIL** photo to: truckstop@pumper.com, truckstop@cleaner.com, truckstop@mswmag.com

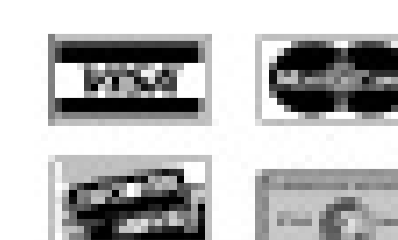

Mid-Continent Truck Sales, Inc.

891 Adkins Hill Rd. • Norman, OK 73072 • 405-329-5365 • Fax: 405-329-5381 • After Hours: 405-826-4469 • www.vacuumtrucksales.com

Trucks - Trailers - Vacuum Tanks - Pumps



1981 Peterbilt 359, Cummins 350, 13-speed, Fruitland RCF500 vacuum pump, 2500 gallon vacuum tank.



2000 IH 4700, DT466E, 5-spd., non-CDL, double frame, new Wally 403HR vacuum pump, new 1600 gallon vacuum tank.



1998 Freightliner FL60, Cummins 5.9 (210 hp), 6-spd., Masport H75V vacuum pump, General 47 series triplex, 1100/200 gallon vacuum tank.

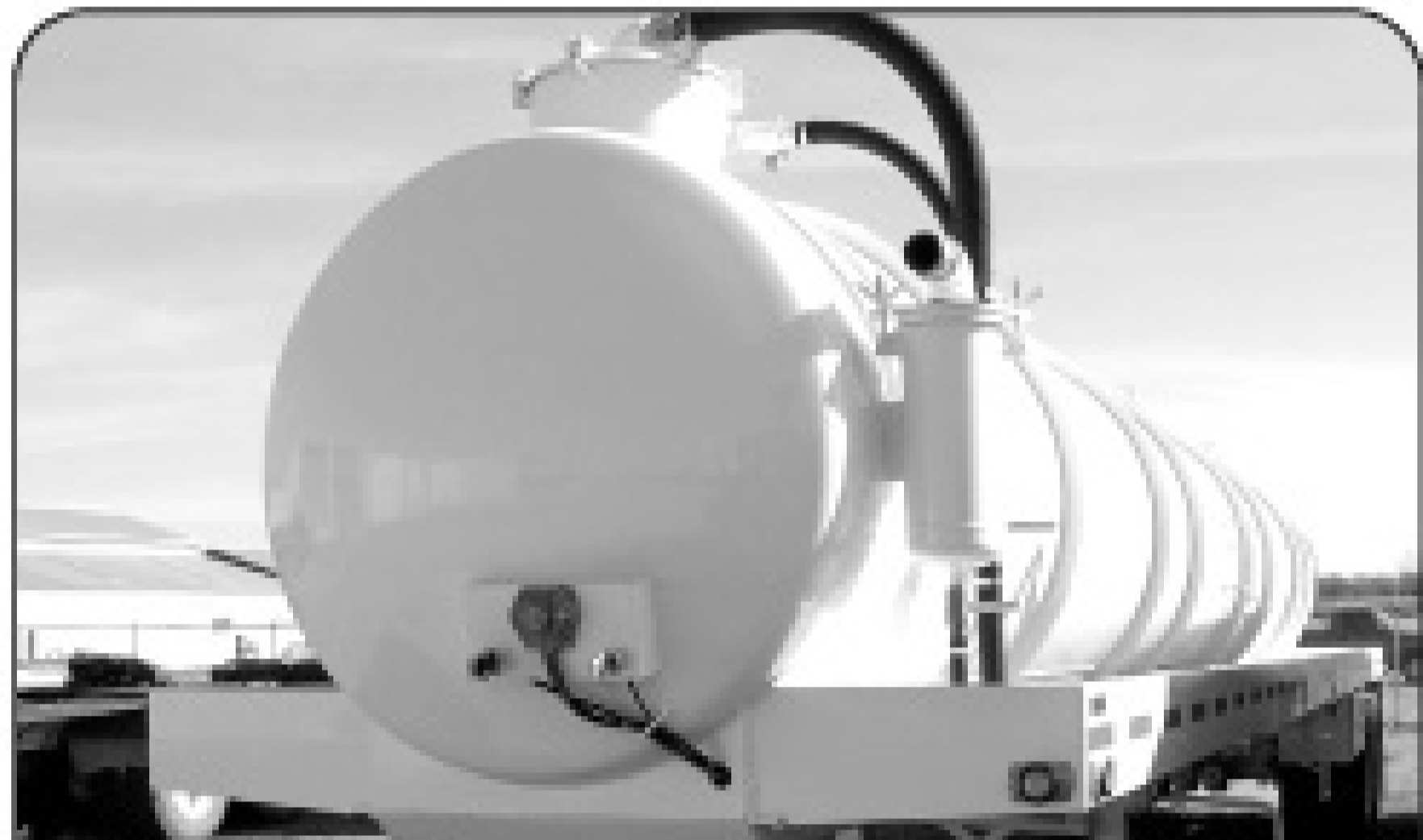

New Fluidmaster 5460 gal. vacuum trailer in stock. Also several used vacuum trailers in stock.



1999 IH 9900, Detroit 60 series (430/500 hp), 10-spd., new Wally 753LN vacuum pump, new 3000 gallon vacuum tank.



1989 Chevrolet C70, 8.2 ltr. diesel, 5+2 air brakes, double frame, MEC 5000 vacuum pump, 1500 gallon vacuum tank.



2002 Freightliner FL70, Cat 3126 (210 hp), 6-speed, new Masport HXL75V vacuum pump, new 2300 gallon vacuum tank.

CALL US BEFORE YOU BUY!

MID-CONTINENT TRUCK SALES

manufactures and stocks all necessary components to complete your vacuum system.

Whether it's pumps, valves, moisture traps, oil catch mufflers, pump frames, etc.



NEW 3800, 3400, 3000, 1600 GALLON VACUUM TANKS IN STOCK!

Kerr
Pumps
Since 1946

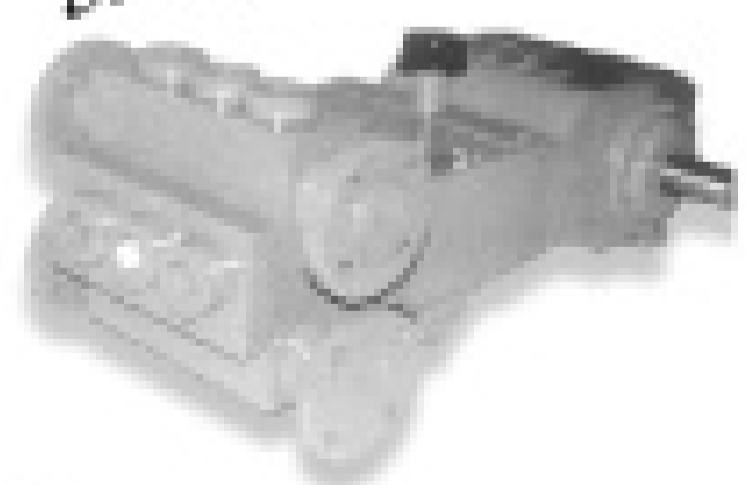

Masport

NVE

AUTHORIZED DISTRIBUTOR



vallenstein
vacuum pumps

BOWIE



FLUID AND SLURRY
PUMPS

WE CARRY MOST BRANDS OF VACUUM PUMPS AND PARTS!



WE WILL BUILD TOILET UNITS TO YOUR SPECS!

Call DAVE PERRY for TRUCK quotations and CHUCK RODGERS for TANK quotations.

- ▶ Advertising
- ▶ Aerators
- ▶ Bucket Machines
- ▶ Businesses
- ▶ Business Opportunities
- ▶ Cable Machines
- ▶ Computer Software
- ▶ Dewatering
- ▶ Drainfield Restoration
- ▶ Drain / Sewer Cleaning Equipment
- ▶ Dredges
- ▶ Excavating Equipment
- ▶ Hazardous Waste Units
- ▶ Hydroexcavation
- ▶ Jetties-Trailer
- ▶ Jetties-Truck
- ▶ Jet Vacs
- ▶ Lease Financing
- ▶ Locators
- ▶ Miscellaneous
- ▶ Parts & Components
- ▶ Pipeline Rehabilitation
- ▶ Portable Restrooms
- ▶ Portable Restroom Sinks
- ▶ Portable Restroom Tanks
- ▶ Portable Restroom Trailers
- ▶ Portable Restroom Trucks
- ▶ Positions Available
- ▶ Positions Wanted
- ▶ Positive Displacement Blowers
- ▶ Pressure Washers
- ▶ Pumps-Dredge
- ▶ Pumps-High Pressure
- ▶ Pumps-Submersible
- ▶ Pumps-Vacuum
- ▶ Pumps-Water
- ▶ Rodding Machines
- ▶ Roll-Off Containers
- ▶ Roll-Off Trailers
- ▶ Roll-Off Trucks
- ▶ Root Control
- ▶ Safety Equipment
- ▶ Septic Tank Forms
- ▶ Septic Trucks
- ▶ Service / Repair
- ▶ Slide-In Unit
- ▶ Sludge Applicators
- ▶ Tanks
- ▶ Tools
- ▶ Trailers-Vacuum / Tanker
- ▶ TV Inspection
- ▶ Vacuum Loaders
- ▶ Vanes
- ▶ Vehicle Tracking
- ▶ Wanted
- ▶ Wastewater Transfer
- ▶ Waterblasting

ADVERTISING

SANITATION POSTCARDS & BUSINESS CARD MAGNETS: Remind your customers and prospects with color postcards and magnets. Economical marketing tools. Tradeshow handouts as well. Call Toll Free 888-334-4553. Visit www.postcardprinting.com. (PBM)

BLOWERS

VFC200P-5T, FUJI Pumps, Regenerative Blowers, Ring Compressors. All models, accessories. Authorized distributor. Authorized parts and repair center. Call 888-227-9822. www.carymfg.com (PBM)

BUSINESSES

Well established portable restroom business, since 1994, Osceola County Michigan. Sells with or without trucks. Serious inquiries only. 231-250-1483. (PTBM)

Complete portable toilet operation for sale located in North Georgia. Will sell part or all. 160 Poly-Portables, 2006 F-350a portable pumper, 4x4 diesel, holding tanks, etc. Price on request. Will consider turn-key or relocation. Will consider trade for free and clear assets. 706-379-2635 or 706-994-3655. Email: mvminvest@windstream.net. (P8)

WELL ESTABLISHED PORTABLE RESTROOM BUSINESS FOR SALE IN MINNEAPOLIS/ST. PAUL METRO. Locally owned and operated with excellent customer base. Standard units, hook units, handicaps, hand-wash stations and trucks, in full operation. Turn-key with still a lot of growth potential. Serious inquiries only. 651-688-7373. (P8)

Long Island, New York: For Sale: Cesspool, Septic, Sewer and Drain Cleaning Company For Sale. 2 pump trucks, 2 porta-pottie trucks (service and delivery). Quality workmanship, has established 3000+ loyal customer base. Great opportunity for right person. Jump in on busy season! Money maker! Debt free! Office/shop/yard also available. Call for more information. 631-472-0677. (PBM)

BUSINESSES

Florida - Installation, repair, pumping business for sale in South-Central Florida. Willing to qualify license. Advertising and name recognition in place. 863-441-5264. (P10)

Portable toilet and septic pumping business for sale in North East California. Have been in business for 16 years. Will consider splitting the business. Call 530-251-7447 for more info. (P9)

BUSINESSES WANTED: Septic pumping, grease trap, drain cleaning and other ancillary businesses wanted. We are buying well run businesses in New England, Mid-Atlantic and Florida. All opportunities will be given proper consideration. Confidentiality ensured. Will move quickly for the right opportunity. Serious inquiries only. Please contact Richard Bedard @ Blue Water, 617-326-3344 or rbedard@bwseptic.com. (CPBM)

Well established cesspool, line cleaning and installation company located in Suffolk County, NY. All equipment in excellent condition. Flatbed backhoe trailer, dump truck, 2 pump trucks, van with compressor. Many extras. Call for more info. 631-874-5488. (P8)

Central Wisconsin septic pumping, installation and repair. Tri-axle dump, excavator, posi track pickup, 2 trailers and phone number. Home, shop, and acreage available. \$350,000 high profits in slow times. septicbiz4sale@yahoo.com. (P8)

BUSINESS OPPORTUNITIES

National Grease Recycling Inc. Let us teach you how to recycle restaurant's waste fryer grease and oil (yellow grease) only. **No trap grease.** Big \$. Over 30 yrs. experience. Will guide you through complete process from collection to processing to marketing to end users. Don't lose your trap business to competitors that offer both services. Call for information. Dewey Walker. 813-752-9535 or 813-758-2552. (PBM)

BUSINESS OPPORTUNITIES

Attention PolyJohn Owners: Receive a **free CD-Rom** of our products to use in your company marketing efforts. Ask your PolyJohn business coach in your area to send you this material today. 1-800-292-1305 Kell. (PBM)

Innovative company with a next generation product is looking to add a business partner. Ideal candidate would have established relationships with portable restroom operators and be interested in an ownership position. International interest welcomed. Serious inquiries only. 630-779-2696. (PT8)

WWW.ROOTERMAN.COM. Franchises available with low flat fee. New concept. Visit web site or call **1-800-700-8062 x26**. (CPBM)

COMPUTER SOFTWARE

Pumper Plus Billing Software: Regularly \$795. Mention this ad in Pumper.com and purchase for only \$595. Pumper Plus is a billing software package from Galaxy Systems, www.galsys.com/pumperdemo.asp, that handles billing for septic pumping and portable toilet service-type companies. Inquire at solutions@galsys.com or call 800-985-3029. (PBM)

DEWATERING

Buy - sell - trade - lease: Filter presses, belt presses, vacuum filters, filter cloth, dewatering bags, tanks, mixers and more! Call Waste Treatment Equipment Specialties at 440-808-8844. **www.wescoequip.com**. (PBM)

Alar, Model 650, very good cond. Completely automatic with all controls and panels, filters down to 1/2 micron, sludges generated by septic and grease haulers. Reducing BODs, F.O.Gs, TGS, total phosphorus, meters and NH3-N. 770-917-0377. (PBM)

DREDGES

Seepex sludge & polymer mixing & pumping unit. 5 years old. Excellent condition. Asking \$20,000 OBO. Call 1-506-672-2100. (PBM)

GREASE TRAP SEPARATOR TANK

Grease Trap Separator Tank for Truck. SAVE MONEY, fuel, dump fees and wages. Proven record. References available. Revolutionary design. Call 239-731-2587 for info. & free DVD. (P8)

HAZARDOUS WASTE UNITS

ATTENTION: Fleet of Mack vacuum waste oil trucks for sale/trade by owner. Assorted size MC312 aluminum vacuum tanks. 417-619-5111. (PBM)

2010 Peterbilt 340s **loaded with every option except with automatics** with a new Presvac 3200 gallon stainless steel, DOT 412 certified, **full open rear door, dump style units.** PVB750 vacuum pumps. (Stock #13384 F) *In production.* **www.VacuumSalesInc.com, (888) VAC-UNIT (822-8648).** (PBM)

Brand new 2009 Sterling Acterra with Presvac DOT 407/412, 3250 US gallon, full open rear door and dump body, Cummins ISC-315, 330 hp, 10-spd. trans., PV750 vane pump, 28.5' Hg., 400 cfm. 888-564-0202. www.kmhequip.com. (P8)

2000 Mack RD686 triaxle with 4,000 DOT certified dump and door Presvac vacuum tank. New Moro PM100 vacuum pump with new NVE valves and tank inspections. 350 hp engine with 44K rears with 15K pusher, 18K ft. axle. Must see. KLM Companies. 617-909-9044. (P8)

1994 GMC Topkick cab and chassis with a Presvac 2300 US gallons, DOT certified vacuum/pressure tank. "As is." In stock. (Stock #8094V) **www.VacuumSalesInc.com, (888) VAC-UNIT (822-8648).** (PBM)

PLACE YOUR AD ONLINE AT www.pumper.com - IT'S ALWAYS THERE TO MEET YOUR BUSY SCHEDULE

HAZARDOUS WASTE UNITS

2009 Sterling LT9500 triaxle with a new Presvac, **Powervac 3800**, 3,250 gallon (US), DOT, wet/dry industrial, vacuum tank loader. (Stock #13336) **www.VacuumSalesInc.com, (888) VAC-UNIT (822-8648).** (PBM)

2010 Peterbilt 340s **loaded with every option except with auto-matics** with a new Presvac 3200 gallon carbon steel, DOT 412 certified, **full open rear door, dump style units.** PVB750 vacuum pumps. (Stock #13384 C, D & E) *In production.* **www.VacuumSalesInc.com, (888) VAC-UNIT (822-8648).** (PBM)

1986 Polar 5,000 gallon 316 stainless steel MC 307/312 vacuum trailer with new vac pump and hyd. drive. New tank inspections with new NVE valves. Spring suspension. In excellent condition. Must see. KLM Companies 617-909-9044. (P8)

NEW Presvac 5500 gallon c/s DOT certified vacuum tank unit, self-contained. **In stock!** (Stock #13373) **www.VacuumSalesInc.com, (888) VAC-UNIT (822-8648).** (PBM)

1997 Pete 365 Cat, 400 hp, power triaxle with DOT haz certified, dump door, 4000 gallon Presvac vacuum tank, Presvac PV750 vacuum pump with new valves and tank inspections. 46K rears, 20K pusher with 20K front axle. Runs excellent. KLM Companies 617-909-9044. (P8)

JETTERS-TRAILER

New PipeHunter Model 38T44 jetting unit, trailer mounted unit, w/335 Poly water tank, 4,000 psi @ 25 gpm, 600' of hose and attachments. **In Stock!!!** (Stock #13317) **www.VacuumSalesInc.com, (888) VAC-UNIT (822-8648).** (PBM)

2 SECA trailer jets. Both have Myers 35 gpm, 2000 psi pumps. New paint on both. Located in Dallas. 972-938-1905. **www.empireequip.com.** (CPBM)

New O'Brien Model 3518-SC jetting unit, trailer mounted unit w/350 poly water tank, 4000 psi @ 18 gpm, 400' of hose and attachments. **In Stock!!!** (Stock #3024V) **www.VacuumSalesInc.com, (888) VAC-UNIT (822-8648).** (PBM)

JETTERS-TRAILER

New 2007 Harben 4018 DTD E45 Series Jetter Trailer, 4000 psi up to 18 gpm, 300 gal. water tank, Deutz F4L2011 4-cyl. diesel with 10 hours. **www.kmhequip.com. 888-564-0202.** (P8)

JETTERS-TRUCK

2003 Sterling LT with Camel Super 200 Combination truck, 16-yard debris tank, 1,500 water. In excellent condition. Low miles. \$110,500. KLM Companies, 617-909-9044. (P8)

1994 Ford F-800, manual transmission, 210 hp diesel, Ram Rodder w/Myers pump, 1,000 gal. water tank, 525' 1" hose, 180-degree pivoting reel, winter recirculator, 162,500 miles. \$7,800. 815-741-4440. (PBM)

2006 GMC TC6500 cab & chassis truck mounted jetting unit with JET EYE camera system, 3,000 psi @ 50 gpm, 1,000 gallons water, 600' hose, 500 cfm blower, debris tank and attachments. **Available for purchase or rent!!!** (Stock #13234) **www.VacuumSalesInc.com, (888) VAC-UNIT (822-8648).** (PBM)

JET VACS

1989 International Camel with 12-yr. debris tank, extendaboom, 1500 gallon water tank, Meyers pump, 80 gpm, 2000 psi, ex-municipality. Price \$34,320. Call 503-969-9557 or 503-682-2723. (CP8)

2008 Sterling LT7501 with a Vac/All Jet Model AJV1215 1500 water comp, 12-yr. debris body, Roots 824 PD blower, 80 gpm @ 2000 psi jetting system with 600' of 1" hose. **Available for purchase or rent!!!** (Stock #0329V) **www.VacuumSalesInc.com, (888) VAC-UNIT (822-8648).** (PBM)

2004 Sterling LT7500, AquaTech B-10, Cat C-7, Eaton 10-speed, 60,000 GVW, 10 CY debris, 1000 gal. water, 80 @ 2000, Roots 824 blower, General MS55 pump, 64,500 miles, 3034 hours. 888-564-0202; **kmhequip.com.** (P8)

2006 Volvo VHD 64F, AquaTech B-12 combo with hydro-excavation kit, 980,000 BTU boiler 2500 PSI @18 GPM, Jetter 2500 PSI @ 65 GPM, 1000 gal. water, Hibon TS56 blower, 12 CY debris. 888-564-0202; **kmhequip.com.** (P8)

JET VACS

1998 Vactor 2112 on a Freightliner, 40,946 miles, **PD blower**, 80 gpm, 2500 psi, extendible boom, articulating hose reel, accumulator, new paint. Was a city owned unit. Located in Dallas. 972-938-1905. **www.empireequip.com.** (CPBM)

1993 International Camel, diesel, push plate, large blower, 1000 gallon water tank, low miles, excellent condition, ex-municipality. Price \$43,120. Call 503-969-9557 or 503-682-2723. (CP8)

2007 Volvo VHD 64F, VacAll jet vac, VE D12 365 hp, Eaton 10 speed, 12 Cy debris, 1500 water, 80 @ 2000, Hibon TS56 blower, low miles & hours. Also have available with hydro-exc. kit. 888-564-0202; **kmhequip.com.** (P8)

1998 Vac-Con V312THA on a Ford LT8000, 3-stage fan, 65 gpm, 2000 psi pump, extendible boom, articulating hose reel, 12 yard debris tank, new paint. Was a city owned unit. Located in Dallas. 972-938-1905. **www.empireequip.com.** (CPBM)

2001 Vac-Con Model V390 SHA, 3-stage fan, 80 gpm 2000 psi pump, 600' of new 1" jet hose, new paint. Was city owned. 972-938-1905. **www.empireequip.com.** (CPBM)

1992 International 2554 cab and chassis with a Vac-Con Model V211TR combination unit, 12-yard debris body, 1000 gal. water, front mounted hose reel, extendable top load boom. **In stock.** (Stock #5045) **www.VacuumSalesInc.com, (888) VAC-UNIT (822-8648).** (PBM)

2002 Vactor 2110-j4 combo unit, 2500 psi, 80 gpm, mounted on Int. 2554. Allison a/t. John Deere aux. engine. 732 fan hours, 5700 engine and 34,500 truck. Pristine cond. 540-921-3542 Chuck. (P9CM10)

1996 Vactor Model 2110, **PD blower**, 65 gpm, 2000 psi pump, 10-yard debris tank, new paint. 972-938-1905. **www.empireequip.com.** (CPBM)

(1) 2002 Vactor 2110; (1) 2002 2115; (1) 2003 2110. **All PD units.** All were city owned units in excellent condition. Located in Dallas. 972-938-1905. **www.empireequip.com.** (CPBM)

Jack Doherty Supplies Inc. offers a full range of late model combo units and DOT industrial vacuum loaders. Call us @1-800-3DOHENY. (CPBM)

JET VACS

1998 Vactor 2110 on a Freightliner FL80, 28,213 miles, 2-stage fan, 80 gpm, 2,000 psi pump off system accumulator. Was a city owned unit. Located in Dallas. 972-938-1905. **www.empireequip.com.** (CPBM)

LEASE/FINANCING

BSM Financial Group is a nationally recognized finance company. We offer flexible payment schedules for all types of equipment new or used. Trucks, pumps, jetters, portable toilets, and software easily financed. We do first time start-ups, established businesses, and challenged credit. **Call Brett at 877-524-7972 or email brett@bsmfinancialgroup.com.** (PBM)

North Star Commercial Credit: Commercial Loans for Trucks or Equipment. Flexible purchase programs to fit your budget. 21 yrs. in the industry. Contact **Tom Myers - 877-804-2274.** (CPBM)

VSI Equipment Finance. New and used equipment financing available with competitive rates. Access to quality pre-owned and new vacuum tankers. **Call JR @ 609-868-7634.** (PBM)

Capital Partners — Your One Stop Financing Partner. A simple phone call allows us to get you pre-approved for **ANY** new or used equipment. Call today to see why we are the Finance Leader in the Pumper/Cleaner Industry. Contact Jim Stekl @ 866-769-2345. (P11C12)

MISCELLANEOUS

Top quality aerators at wholesale prices. We have replacement units for most name brands and also carry Linear Regenerative Rotary Vane pumps. Flagg Air, Gast, Thomas, FPZ, Secoh, Medo and more. Call a company that understands aerators and aeration systems. Septic Services Inc. 800-536-5564. (CPBM)

Looking for ways to expand your business and cover fixed overhead? FOR SALE: Used 20' and 40' shipping (storage) containers. Some units modified into job site offices. Pictures available at **www.a1portables.com.** Located in Central Kentucky. Call 859-255-6605 or email eric@a1portables.com. (P8)

MISCELLANEOUS

HEPA Filter, Portable: 8000 cfm rated at 99.9 @ .3 microns, 12" inlet. Like new. Price \$5,500. (New \$14,000) 888-739-0838. (P8)

PARTS & COMPONENTS

PARTS & SERVICE for vacuum pumps and vacuum tanks. Vacuum pumps also in stock. 800-909-6909. Ask for Ken or Randy. (PBM)

PIPELINE REHABILITATION

Max Liner lining equipment, ready to work. Max Cutter 10-12 Mini complete set also available, two 95-gal. over-pack drums, an air operated open drum mixer, one 18" width x 24' length gravity conveyor and a pull behind Ingersoll Rand 175 diesel air compressor. Will sell together or separately. Call Harry 843-556-4320. (CMP8)

PORTABLE RESTROOMS

Portable Restrooms, construction units. PolyJohns (grey) American Polys (grey) \$100 - \$200. 150 available. Also have (2) 2003 Satellite Ford 550's, \$18,000 ea. Central NY area. 315-247-0582. (PT8)

150 Used Synergy World High Tech 1, kelly green sides with a gray front, good condition. \$200 each. Call Bill Jr. 614-497-1776 OH. (P9)

100 PolyJohn and Tuff-John toilets, construction grade. Groups of 10 units for **\$1,350 or \$150** each. We also sell shipping containers and units may be purchased together for further discounts and ease in transportation. Located in Central Kentucky. Call 859-255-6605 or email eric@a1portables.com. (P8)

50+ Synergy World toilets, 3 ADA toilets, 3 holding tanks, 1994 IH service truck. Located in Texas. \$30,000. Email: toiletbusiness@att.net. (PT8)

150 PolyJohn units. Aqua and yellow. Construction grade. \$150 to \$250 each. Southern MI. Ph: 248-437-5595 Email: johnsanit@yahoo.com. (P8)

Satellite Tufway Units. Tan. All in good condition, 100's for sale. \$200 each. 386-931-0291. Florida. (P8)

BUY IT - SELL IT - PLACE IT - www.pumper.com - AVAILABLE ANYTIME, ANYWHERE, ANY DAY

PORTABLE RESTROOMS

350 used Poly and Satellite portable toilets for sale in Utah. \$225. Volume discounts available. Contact Ryan at 801-430-7287. (P8)

100 Red, White & Blue Poly-Portable (Integra) units in excellent condition. \$275-\$350 each. Please call 352-572-2687. (PBM)

200 Used Fiberglass Toilets for Sale. Excellent condition, some as new as 2007, some older. \$75-\$100 each depending on age. Call Lorraine 847-955-1214. (P9)

Used PolyJohn, PolyPortable tan units, plastic skids, average to excellent condition. \$225-\$325 each. Can arrange shipping. Call Bob at 1-352-796-4540. (PBM)

Over 600 PolyJohn units 1-2 years old. Starting at \$300 each. Minimum purchase of 26 units. 772-562-4604. kim@reliablepolyjohn.com. (PBM)

Portable Toilets: Poly constructed, molded seat, urinal, latching door. Handicap accessible units available. New and used. CCI/Brian Touey 805-896-3777. (PBM)

PORTABLE RESTROOM TANKS

300 gallon, 225 waste/75 water, brand new, Battioni pump. \$5,500. 315-375-7867. (PBM)

PORTABLE RESTROOM TANKS

Single or multiple compartment tanks. Choose mild, stainless, or galvanized steel. Capacities from 100 to 6000 gallons, any diameter. Parts and accessories to build your own and save money. 800-545-0174. www.tanksandpumps.com. (PBM)

PORTABLE RESTROOM TRAILERS

'08 ACSI Advantage Series 12' Restroom Trailer; NEVER USED. 2 women's stalls, 1 urinal, 1 man stall. **\$28,000.** Call for further details. **Crescent Tank Mfg. 585-657-4104;** www.crescent-tank.com. (P8)

Party Wagon - Portable Entertainment Station walk-in restroom with toilet & sink, stereo system, big screen TV, DVD/VCR, satellite TV system, propane gas grill, built-in beer tap. Perfect for the race, ball games or camping. \$9,900. Call Brian Wintjen at 843-529-1399. (P9)

2008 Wells Cargo 3-stall restroom/shower combo, used 3x short term, excellent condition, pewter color. Located in Northern CA. \$23K. Call 707-545-4847. (P8)

1997 24' Olympia, \$12,000; 2001 26' Olympia Executive, \$17,000. Call Bill Jr. 614-497-1776 OH. (P9)

PORTABLE RESTROOM TRAILERS

2008 Sanddollar 8 x 12 trailer for sale. Two ladies stalls & sink; one mens stall, one urinal & sink, upgraded interior. Asking \$14,500. 864-751-4209. (PT9)

Restroom Trailer - Platinum Series: 30', new and used. Women's - 4 stalls, 2 sinks. Men's - 2 stalls, 3 urinals, 2 sinks. CCI/Brian Touey 805-896-3777. (PBM)

2008 24' Olympia Executive, never used, paid \$28,700, will take \$26,000. 2004 Olympia 20' Executive, excellent condition, \$18,000. 2000 Olympic 30' Luxury Liner, \$20,000. 2001 Olympic 26' Executive, \$17,000. Call 866-883-9538 NY. (PT8)

New 28' - 12 standard unit or 3 A.D.A. \$6,500. View at www.hackerbuiltinc.com. Build to order trailers. Leave message at 507-272-9351 or call Tom at 507-951-2188. (P8)

Restroom Trailer - Gold Series: 32', new and used. Women's - 5 stalls, 2 sinks. Men's - 2 stalls, 2 urinals, 2 sinks. CCI/Brian Touey 805-896-3777. (PBM)

New and used **RESTROOM TRAILERS** available immediately. 8 to 34 foot luxury trailers. Comforts of Home Services Inc. 877-382-2935. (PBM)

PORTABLE RESTROOM TRUCKS

2000 Ford F550, auto with A/C, 950/250, 115,000 miles, **\$27,000.** Also, 2007 Dodge 3500, auto with A/C, 40,000 miles, 500/200, **\$34,000.** Both trucks in good condition. Pictures available. Located in Central Kentucky. Call 859-255-6605 or email eric@a1portables.com. (P8)

2004 4300 International, 25,500 GVW, DT466, Allison, A/C, air-brakes, 3-compartment aluminum tank (450/1400/250), M-10 Water-cooled pump, spot lights, 2 Burk water pumps for fill and spray down, restroom carrier. Pictures www.acoinc.com/classified. Location Phoenix, AZ and Las Vegas, NV. \$45,000. 208-362-3193. (P8)

1999 Ford F550, 190,841 miles, manual 5-spd. trans., red/white exterior, grey interior, chrome wheels, Keith Huber portable unit. Garage kept, well maintained. Call 717-567-3848. Ask for Joe. (P8)

1996 Ford Super Duty portable toilet service truck, 600/200 split, 126,300 miles, running condition. Vac pump works, needs rack, sold "as is." Asking \$7,000 OBO. Truck is in Illinois. Call 877-919-2378, ask for John. (P7)

2004 Sterling Acterra, 125,000 mi., automatic, hydraulic brakes, A/C, flatbed, hydraulic gate, PTO pump, carbon tank 350/150, non-CDL. \$31,500. (V-204) Call Pete 732-895-6533. (P8)

TANK ONLY - Do you have an existing chassis ... We have a Crescent Rectangular Vacuum Tank ... Crescent Tank Mfg. will up-fit at our facility or ship to you tank only. Call to get tank only quote. **Crescent Tank Mfg. 585-657-4104;** www.crescent-tank.com. (P8)

2000 International 4700, 166K mi., stick shift, air brakes, trident stainless steel tank 250/1100/250, underhood pump Masport M2DES, \$13,000. (J-51) Call Pete 732-895-6533 for more info. (P8)

2000 International 4700, 192K, 1-owner, 25,500 GVW, 900/300/150 boom, chemical pump hose. \$25,500. Also 2000 International 4700, 230K. \$25,500. Also 1998 International 444 low pro, 205K miles. \$22,500. Call 256-757-9900. (P8)

PORTABLE RESTROOM TRUCKS

Satellite steel tank, 450 waste/250 fresh. Unit pulled from F450, good for start-ups, 2nd truck or trailer unit. \$1,495 OBO. 606-439-4887. (PT8)

1995 International 4700 with a Prime 1,500 US gallon, 2-compartment (1000/500 split) carbon steel; portable toilet service unit. "As is." **Available!!!** (Stock #3469C) **www.VacuumSalesInc.com, (888) VAC-UNIT (822-8648).** (PBM)

2000 International 4700, no motor, no transmission on frame, trident stainless steel tank 250/1100/250, \$13,000. Call Pete 732-895-6533. (P8)

PRICE REDUCED: 2004 Crescent Tank Chevy 4500 Truck: 650 waste, 250 fresh, carry 6 units, Masport pump & new Masport traps; diesel, automatic, 111,710 miles. Factory refurbished vacuum tank, good condition. **\$37,000.** Crescent Tank Mfg. 585-657-4104. (P8)

1998 International 4700 with a 1,500 US gallon, 2-compartment (1100/400 split), carbon steel, portable toilet service unit. (Stock #8734C) **www.VacuumSalesInc.com, (888) VAC-UNIT (822-8648).** (PBM)

2004 International 7400, 110,000 miles, automatic, air brakes, A/C, Presvac carbon tank 250/1100/250, 2-unit carrier, PTO pump Masport HXL2F, \$39,000. Call Pete 732-895-6533. (P8)

2001 International 4700, 150K, 1-owner, 25,500 GVW, air brakes, 900/300/150 tank, hose boom, chemical pump hose on wand. \$32,500. Also 100 used portable restrooms. \$125-\$250 each. Call 256-757-9900. (P8)

1998 International 4700 cab and chassis with a Coleman 1,000 US gallon, 2-compartment (700/300 split) carbon steel portable restroom service unit. **Available!!!** (Stock #1327C) **www.VacuumSalesInc.com, (888) VAC-UNIT (822-8648).** (PBM)

2005 International 4300, 123,000 mi., recently rebuilt engine, automatic, air brakes, A/C, carbon tank 200/1000/200, 2-unit carrier, PTO pump Masport HXL2F, non-CDL. \$32,000. (R-205) Call Pete 732-895-6533. (P8)

Classifieds Category List :: Pumper Magazine

http://www.pumper.com/classifieds/

WWW.ONSITEINSTALLER.COM | WWW.PROMONTHLY.COM | WWW.CLEANER.COM | WWW.MSWMAG.COM | WWW.PUMPERTRADER.COM | WWW.PUMPERSHOW.COM

Pumper SUBSCRIBE EDITORIAL CLASSIFIEDS VIDEO ADVERTISING

Looking to BUY or SELL?
Just Submit Your Classified Ad ONLINE!

Only \$1.00 PER WORD (\$20 Min.)

Easy & Secure!

Your ad will be posted on the Pumper Web site within two to three business days after received.

Just go to www.pumper.com; click on "Classifieds;" click on "Place a Classified Ad;" fill in the online form.

PLACE YOUR AD ONLINE AT www.pumper.com - IT'S ALWAYS THERE TO MEET YOUR BUSY SCHEDULE

PORTABLE RESTROOM TRUCKS

2004 International 4200, 120,000 mi., auto, 6.2 diesel, hydraulic brakes, A/C, stainless steel tank 1000/400, 2-unit carrier, PTO pump Masport HXL2F, non-CDL. (V-104) \$38,000. Call Pete 732-895-6533. (P8)

1997 Ford Super Duty portable toilet service truck, 400/250 split, 236,200 miles, running condition. Still on route, sold "as is." Asking \$10,000 OBO. Truck is in Illinois. Call 877-919-2378, ask for John. (P7)

2007 GMC C-5500, 1000 waste, 300 fresh, 51,000 miles, \$46,000. 2008 GMC C-5500, 1000 waste, 300 fresh, 58,000 miles, \$48,000. Both trucks under warranty bumper to bumper. Slide-in tanks 600/200, \$10,000. Portable toilet transport trailers, new and used. Lane's Vacuum Tank Inc. 1-800-592-3308. Rodney Lane cell 270-832-3793. (PBM)

1994 International 4700 with a Keith Huber 1,500 carbon steel portable toilet service unit. (Stock #6499V) **www.VacuumSalesInc.com, (888) VAC-UNIT (822-8648).** (PBM)

2002 International Pumper Truck: 4700 series, DT466, automatic, air brakes, 1200 gallon waste, 300 gallon fresh water, Masport 75 pump. CCI/Brian Touey 805-896-3777. (PBM)

(2) 2006 International 4300 107,000/118,000 mi., automatic, hydraulic brakes, A/C, carbon tank 200/1000/200, 2-unit carrier, \$34,000. (R206/R306) Call Pete 732-895-6533. (P8)

2004 Isuzu NQR, 111,000 mi., automatic, 4 cyl. diesel, aluminum tank 800/400, 2-unit carrier, PTO pump, non-CDL. \$28,000. (V-304) Call Pete 732-895-6533. (P8)

Advertise in Classifieds
for only

\$1.00
PER WORD!

at **www.pumper.com**

POSITIONS AVAILABLE

Moro USA, Inc., a rapidly growing company, is seeking an organized self-starter to fill full-time sales position. Experience in the sales field required. Bi-weekly traveling is mandatory for this position. Full benefit package including health, disability and life insurance, vacation, holidays and retirement plan. Salary will be based on experience. Send resume with salary requirements to Moro USA East, Inc., PO Box 632, Union, MO 63084, fax to 636-583-2044 or email to morousa@charter.net. (P8)

PRESSURE WASHERS

2 - Sagino high pressure washers with 150 hp electric motor driven, 300 bar/4500 psi Tri-prex pump, ss manifold and fittings, skid mount, insulated sound proof box. \$8,500 each or \$15,000 both. Call 503-969-9557 or 503-682-2723. (CP8)

PUMPS-HIGH PRESSURE

Two (2) NLB Pump Conversion Kits. Converts 6K/8K/10K to a 20K pump. Originally purchased 9/2007 for NLB 605 10K units. New, unused, complete in factory contractors boxes. Price each: \$22,000 OBO. Contact: Greg Sponseller 330-482-0893. (P8C9)

PUMPS-SUBMERSIBLE

(2) 4" submersible pumps with self-contained Lister diesel engine, hyd. drive powerpac. Separate hyd. tanks, both on portable skids. Will run (2) 4" pumps or (1) 6". Must see. \$12,500. KLM Companies 617-909-9044. (P8)

Wholesaler for Hydromatic, Zoeller, Myers, Liberty and ABS pumps. We also supply Grinder pumps and basins. Will help you size them. Septic Services Inc. 800-536-5564. (CPBM)

PUMPS-VACUUM

Vacuum Pumps - New, used, or rebuilt. 30 to 900 cfm. All major brands; air, water, or fan cooled. Rebuild specialists - rebuilt PB, M3, M10, and others available. 800-545-0174. **www.tanksandpumps.com.** (PBM)

PUMPS-VACUUM

Complete line of Moro, Conde and engine-driven, stand-alone pump systems, DC10 washdown pump. Call us for any of your vacuum truck parts from shut-off valves, primary and secondary valves, hoses, vacuum pumps and drive systems. Septic Services Inc. 800-536-5564. (CPBM)

Need a vacuum pump for your portable pumper? Try our new 30 cfm, 12 volt system. Less noise, no fuel. Automatic oiling, cheaper than a gas engine. 800-545-0174. **www.tanksandpumps.com.** (PBM)

New **Masport** and **Jurop** vacuum pumps. Compare our price before you buy. W-K Machine & Supply Co. Call 1-800-633-8947. Distributor. (PBM)

RENTAL EQUIPMENT

Liquid vacs, wet/dry industrial vacs, combination jetter/vacs, vacuum street sweeper & catch basin cleaner, truck & trailer mounted jettors. All available for daily, weekly, monthly, and yearly rentals. **VSI Rentals, LLC, (888)VAC-UNIT (822-8648) www.vsirentalsllc.com.** (PBM)

ROLL-OFF CONTAINERS

Rolloff Containers (20-yd & 30-yd) 5 yrs old, \$2,500 each. Freight not included. Call Brian Wintjen 843-529-1399. (P9)

ROLL-OFF TRAILERS/TRUCKS

2003 Mack Granite Rolloff Truck, Galbreath hoist, Pioneer tarper, 196,000 miles, 1-owner. \$52,500. Call Brian Wintjen 843-529-1399. (P9)

SEPTIC TRUCKS

1984 Mack with 18' heavy duty all hyd. set bed. 20K winch, 11' boom, hyd. outriggers. \$30,000. Email: toiletbusiness@att.net. (P18)

1999 9200 series Int'l with 2004 300 fresh/3300 waste hoist tank full open door; Challenger 460 pump; Jetter: 3000 psi 11 gpm, Cat C-12 w/Jake, 10-spd.; 301,000 miles, good truck & tires, works everyday; \$46,000 OBO. 1-877-89BURNS. (P8)

SEPTIC TRUCKS

TWO TRUCKS FOR SALE: 1977 GMC, gas engine, 2000 gal. tank, lift gate: 1984 Ford 9000, diesel, split tank - 3200 gal. total, with jetter. Both for \$9,000. Oregon Coast. 541-921-7377. (P10)

2002 International 4400 DT466 with 2500 gallon tank. Tekflo pump. 139,000 miles, Am/Fm, AC, air ride seat. Good clean truck. \$38,000 OBO. 410-275-2647. (P8)

1991 International 4900 cab and chassis with a 1700 US gallon, carbon steel vacuum-pressure tank. Dump type with rail-gear "as is." **In stock!!!** (Stock #1443V) **www.VacuumSalesInc.com, (888) VAC-UNIT (822-8648).** (PBM)

1987 GMC, 3000 gallon tank, 360 Challenger pump, 315 Cummins, tank and pump new in 97, good condition, great starter truck, \$12,000. Call 501-412-4531. (P8)

2000 Volvo WG64 with a Pikrite 4,000 gal. vacuum tank and a Jurop PNR-102 pump. (Stock #9010C) **www.VacuumSalesInc.com, (888) VAC-UNIT (822-8648).** (PBM)

2003 International 7500 with a 3,000 gal. carbon steel vacuum tank unit. (Stock #2319C) **www.VacuumSalesInc.com, (888) VAC-UNIT (822-8648).** (PBM)

2003 Mack CV713 cab and chassis with a 3,200 gal. s/s vacuum pressure tank. Masport pump package. (Stock #3680V) **www.VacuumSalesInc.com, (888) VAC-UNIT (822-8648).** (PBM)

Need a tank and truck, any size, any make truck? Let us help you get the best deal. Custom built to your specs. For information and a price quote call 800-545-0174. **www.tanksandpumps.com.** (PBM)

2004 GMC, 6-speed, AC, Cat diesel, 99,000 miles, 2300 gal. tank, \$44,000. 2001 International DT-466, 270,000 miles with new 2300 gal. tank, \$37,500. 2001 International DT-466, 238,000 miles, 3600 gal. tank, \$45,000. New and used septic and toilet trucks available. Lane's Vacuum Tank Inc. 1-800-592-3308. Rodney Lane cell 270-832-3793. (PBM)

1994 2600 Intl., heavy front, 3500 gal. tank, water-cooled pump, DT66, 8-spd. Asking \$19,000. Call 608-782-7633 or 608-769-4567. (P8)

SEPTIC TRUCKS

1995 International, 3500 gal. tank, 525,000 miles, 75,000 on overhaul, 425 Cat, 8LL transmission, new clutch, new Jurop R260 pump. \$32,000. 724-627-7825. (P8)

2005 Intn'l 4400 auto, 3600 gallon alum. Allied tank (2005 Show Truck), Wittig RFL-100 air-cooled, good rubber, runs great, chrome all around, 190k miles. 1995 Intn'l 4900 6-spd., 2500 gallon pumper, Masport HXL75 water-cooled, runs good and ready to work. 410-257-1999. (P8)

1999 Sterling with a 2,500 US gallon CS dump type unit and pump package. (Stock #2192V) **www.VacuumSalesInc.com, (888) VAC-UNIT (822-8648).** (PBM)

FOR SALE: 2004 Int. 4300 w/2500 gal. tank, 127,000 miles, complete engine rebuild @ 120,000 miles, 500 gpm Transway pump, 4 heated 4" valves. 607-746-3003. (CP8)

1988 R Model Mack, 300 hp, 9-speed, 3600 gallon tank, FI Truck, runs great. Asking \$17,500. 802-868-2088. (P8)

2009 Peterbilt 340 with a Presvac 3600 gallon (US) aluminum vacuum tank unit. (Stock #13337 B,C&D) **www.VacuumSalesInc.com, (888) VAC-UNIT (822-8648).** (PBM)

1990 Ford F800, 5-spd. trans., 2-spd. rear, 2500 gal. pressure vac pump, lift tank, full open rear. \$20,500. 502-352-9613. Frankfort, KY. (PT8)

SERVICE/REPAIR

Sewer Cam Reel, Camera and Locator Repair: 48-hr. turn-around time. General Wire, Ratch, Ridgid, Pearpoint, Electric Eel, Gator Cams, Insight Vision, Vision Intruders. Quality service on all brands. For more info. give Jack a call. Dynamic Cable Repairs, Lodi, NJ 07644. 973-478-0893. (PBM)

SHOWER TRAILER

Shower Trailer - Gold Series: 32', new and used. Men and women sides each have 3 private shower stalls with changing area, 1 restroom stall, 1 sink. CCI/Brian Touey 805-896-3777. (PBM)

SLIDE-IN UNITS

500/250 Slide-In Unit \$8,900. Place in a 1-ton pickup or on a flat bed. **Call 585-657-4104. Crescent Tank Mfg.; www.crescent-tank.com.** (P8)

Used portable slide-in unit, 130/270 steel. Good start-up or backup unit. Ready to work! \$5,000 or best offer. lynn@lynnshoneywagon.com. (P8)

SLUDGE APPLICATORS

1990 AG-CHEM TERRA GATOR, 2004 rebuilt Cummins 6 BTA. For pictures and more information check out our web site www.waltsteuer.com. Contact Walt @ 231-620-3228. (CMP9)

TANKS

FRAC TANKS: New 23,000 gal. portable storage tanks. Also 1 used 12,000 gal. frac tank, excellent condition. View all at www.jimhodelinc.com or call 800-562-8565. (P10)

Boyd 2500 gallon vacuum pressure tank complete with lights and 3" vacuum pump. Good condition. \$5,500. NY. 845-863-6080. (P8)

Vacuum tanks, 100 to 6000 gallons. All options available; hatches, primary, secondary, valves, catwalks, ladders, etc. Everything needed to build your own septic truck. Choose mild, stainless, or galvanized steel. Ask about full open doors. 800-545-0174. www.tanksandpumps.com. (PBM)

New 3400 gallon tank, 20' man-way bottom, 3" intake, 4" dump, hose trays, valves, painted. \$12,000. 4000 gallon and many other sizes available. Delivery available. 800-721-2774. (PBM)

Presvac 2,800 US gallon aluminum tank only. (Stock #7959C) **www.VacuumSalesInc.com, (888) VAC-UNIT (822-8648).** (PBM)

1100 gallon vacuum pressure tank, 12' 3" x 50" diam. Good condition. \$1,000. NY. 845-863-6080. (P8)

TANK TRAILER

NEW Presvac 5500 gallon c/s, DOT certified vacuum tank unit, self-contained. **In stock!** (Stock #13373) **www.VacuumSalesInc.com, (888) VAC-UNIT (822-8648).** (PBM)

TOOLS

T&T Tools: Probes, Hooks. Probes feature steel shafts with threaded and hardened tips. The insulated **Mighty Probe™** tested to 50,000 volts. **Top Poppers™** open manhole covers easily. Free catalog. **www.TandTtools.com.** Phone **800-521-6893.** (CPBM)

Crust Busters - Portable, light-weight machine guaranteed to mix up septic tanks and grease traps! Save time and money! **www.crustbusters.com, 1-888-878-2296.** (PBM)

TOYS

Septic pumper and vacuum die-cast toy trucks in your choice of colors and logos. Several cabs available. Call 877-450-2100 or write to Granite State Collectibles, PO Box 440, New Ipswich, NH 03071. (PBM)

TRAILERS VACUUM/TANKER

RETIRING: 130 BBL self-contained vacuum semi tanker, 36 cyl. diesel, Fruitland pump, belly mounted pressure rings, haz or non-haz, aluminum wheels. Very good condition. Ready to work. Jim 951-545-9604. (P9)

Presvac 5500 gal. 316 stainless steel DOT certified vacuum trailer, new Fruitland 500 vac pump w/complete rebuilt Lister diesel engine. Original tank thickness; new tank inspections, no pitting. Excellent overall condition w/new Imron paint. Must see. KLM Companies 617-909-9044. (P8)

TV INSPECTION

2007 RST Econo Trailer Mainline Inspection System. Posm Pro software, mainline tractor, 1500' reel. \$60K OBO. Steerable storm tractor \$15K and 1545 series push camera \$4K. Call Don 407-402-4829. (P8)

BEST BUY: Must see this 1997 RST video system that includes a P & T, tractor, and an additional mainline camera. Converted ambulance with odometer of 48,000, perfect studio, storage space and safety lights. The software includes printed reports, hard disc, and Sony Photomate. Photos of interior and exterior are available via e-mail. Special Price \$20,000. Call Don at 503-969-9557. (CP8)

TV INSPECTION

Cobra Technologies equipment with 2 Cues cameras and 2 transporters, 1000' of cable on one reel and more than a 1000 on the other reel. All equipment seems to be mfg. in 1998, mounted in a 1995 Chev. W-5 cabover with 20' box. Only 47,000 miles. Lots of spare parts, very nice truck and equipment. Pictures and more details on our web site: letsrollautoandequipment.net; go to medium duty trucks-van trucks. Value priced at only \$29,950. Ned 719-338-3767. (P10C11)

2007 RST Camera mounted in a 12' trailer with air conditioning, two monitors, can be run from inside the studio or from outside on the ground. Not over 3000' run total. Like new! \$42,750. Pictures available via E-Mail: riteway@riteway.com. (CMP8)

FOR SALE: 1992 Ford E-350 van, chassis mount box, new 351 V-8, new auto transmission, A/C, P/S, studio with A/C, built-in storage cabinets and toolbox, 4.5 KW Onan generator, Cues video system Pipe Ranger transporter 8"-36", ultra Shorty transporter 6"-24", Night Owl pan/tilt camera, power reel w/approx. 800' multi conductor cable, HPL-8 lighthouse and HPL-10 lighthouse, 2 monitors, Granite XP Inspection Edition version 2.0 software, Granite XP PACP module. \$48,500 OBO. Ask for Richard or Charles. 1-800-200-0457. (P9)

VACUUM LOADERS

2006 Freightliner FL80 with DOT Dominator tank. \$95,000. 985-707-4444. (P10)

Garage kept 2005 Freightliner full AFME coded aluminum liquid ring vac truck with only 159,000 miles! CAT engine, 2300 psi high pressure jetter, 3500 gallon tank with 300 gallon fresh water supply for jetter. Full dump and rear opening door, all air ride, must see to appreciate. \$179,900. 614-795-1899. (P8)

1996 International 9200 with a 2008 DOT Diamond Series 3000 gal. tank. \$80,000. 985-707-4444. (P10)

1992 Ford with Guzzler 4816 with swing out Cyclone 6,000 CFM blower (4 yrs old). Cat engine with Fuller trans. 150,000 miles, 5,000 hours. Runs very good. \$19,950. KLM Companies 617-909-9044. (P8)

VACUUM LOADERS

(4) 2006 International 7600, Guzzler Ace bed, Cat engine, 27" blower, wet/dry unit. One with blow off system. 205-837-5702. (P8)

2009 Sterling LT9500 triaxle with new Presvac Powervac 3800, 3,250 gallon (US) DOT wet/dry industrial, vacuum tank loader. (Stock #13336V) **www.VacuumSalesInc.com, (888) VAC-UNIT (822-8648).** (PBM)

2004 Kenworth T800, triaxle, 475 hp Cat with Cusco Turbovac, 3,800 cfm, Hibon blower, DOT certified, 3500 gallon, dump door, vacuum tank, Demagg RFL 100 vacuum/pressure offloading pump. Must see. Low hours/miles. KLM Companies. 617-909-9044. (P8)

1999 International **heavy spec** with **Guzzler ace** wet/dry industrial vacuum loader. 8" top load boom truck is in excellent condition. Blower was reconditioned approximately one year ago. RENT ME!!! (Stock #7390V) **www.VacuumSalesInc.com, (888) VAC-UNIT (822-8648).** (PBM)

2000 Sterling with Cusco Mastervac 3,800 CFM 27" blower with 3,000 gallon tank. Wet/dry unit with full open rear door and Moro vacuum offloading pump. Low miles/hours. \$92,500. Ready for work. KLM Companies 617-909-9044. (P8)

VANES

American Industrial Components: Our vanes are manufactured from the highest quality laminated materials available and are fabricated to exact tolerances and specifications. 800-272-7557. (PBM)

We carry **original** Moro factory replacement vanes. **Also factory replacement parts** for Moro vacuum pumps and accessories. Moro USA 1-800-383-6304 or www.morousaeast.com. (PBM)

Dura Comp 535, high-quality non asbestos vacuum pump vanes. Good to 400°F. Buy factory direct and save. Same day shipment on most models. Jurup, Battioni, Moro, Masport, Fruitland, Demag. Long lasting Dura-Comp 535 pump vanes carry a "Money-back" guarantee. Call us today. Powerflo Products 800-758-4788 or 562-997-0720. (PBM)

WANTED

WANTED: Drywell ring forms 600 gallon and 900 gallon size, septic tank form "cleco" 1500 gallon size. Call 269-423-8588. (P8)

Water jetting equipment. We rent, sell and repair water blasters. Visit us at: www.waterjettingequipment.com or phone 714-259-7700. (CPBM)

Wanted to Buy: Vactor 2100s and late model Guzzlers. Cash. Phone 800-336-4369. (CPBM)

WATERBLASTING

NLB 4075D, 40k @ 3 gpm waterblaster, factory trailer mounted with air compressor, includes new hoses in box, 620 hrs. on machine, serviced by NLB, perfect machine, stored inside. \$38,000. Contact Pat 973-476-7194. (CP9)

2006 Hammelmann pump, driven by Caterpillar engine, 750-1,000 HP. Currently set up at 23,000 psi @ 53 gpm. Low hours, container set up by Hammelmann, noise insulated, 800 gallon stainless steel water tank. Replacement value \$400K USD. Offers considered \$200K USD+. Contact Byron; byron@interclean.co.nz or PH 011-64-275-365-276. (PT8C9)

Wheatley 165 Cummins 10K @ 30 gpm. **Wheatley** 125 Detroit 10K @ 20 gpm. **Gardner Denver** 450 Cummins 10K @ 42 gpm. **NLB-Ultraclean** Cummins 36K, 7 gpm. **NLB** 10-600 Cummins 10K @ 104 gpm. **Boatman Ind. 713-641-6006. View @ www.boatmanind.com.** (CPBM)

2003 NLB 10-150 electric waterblaster, (0) hours on unit - never used. Marathon Motor on skid. If you want brand new this is it. Priced to sell @ \$27,500. KLM Companies, 617-909-9044. (P8)

2006 Jetstream 3600 Series, 170 hp John Deere, 1100 hrs., 27 gpm @ 10,000 psi. \$45,000. 440-813-0025. (P8)

NLB 10-250 2000 model year with 1,200 hrs., 250 hp @ 43 gpm. Complete mounted on 1993 International truck with 120,000 miles. Fluid/power end just rebuilt by NLB. In good shape. \$42,500. KLM Companies, 617-909-9044. (P8)

IF YOU ARE USING AN **800 NUMBER** IN YOUR AD, BE SURE IT CAN BE USED IN ALL AREAS NATIONWIDE.

PLACE YOUR AD ONLINE AT www.pumper.com - IT'S ALWAYS THERE TO MEET YOUR BUSY SCHEDULE



Get Results!

Advertise in **CLASSIFIEDS** for only

\$1.00 per word!
(\$20 min.)

**MUNICIPAL
SEWER
&
WATER**

Cleaner Pumper

CLASSIFIED AD FORM

PRO

**ONSITE
installer**

Please print ad legibly below with *correct punctuation* and *phone number*. Circle each word to be bolded, if any. (\$1.00 extra per word)

CHOOSE THE CATEGORY:

- | | | | | | |
|--|---|---|--|---|---|
| <input type="checkbox"/> Aerators | <input type="checkbox"/> Dredges | <input type="checkbox"/> Levels & Transits | <input type="checkbox"/> Positions Wanted | <input type="checkbox"/> Root Control | <input type="checkbox"/> Trailers-Vacuum/Tanker |
| <input type="checkbox"/> Blowers | <input type="checkbox"/> Excavating Attachments | <input type="checkbox"/> Locators | <input type="checkbox"/> Pressure Washers | <input type="checkbox"/> Safety Equipment | <input type="checkbox"/> Trucks (dump/septic/misc.) |
| <input type="checkbox"/> Bucket Machines | <input type="checkbox"/> Excavating Equipment | <input type="checkbox"/> Miscellaneous | <input type="checkbox"/> Pumps-Dredge | <input type="checkbox"/> Septic System Components | <input type="checkbox"/> TV Inspection |
| <input type="checkbox"/> Businesses | <input type="checkbox"/> Hand Tools | <input type="checkbox"/> Parts & Components | <input type="checkbox"/> Pumps-High Pressure | <input type="checkbox"/> Septic Tanks | <input type="checkbox"/> Vacuum Loaders |
| <input type="checkbox"/> Business Opportunities | <input type="checkbox"/> Hazardous Waste Units | <input type="checkbox"/> Pipeline Rehabilitation | <input type="checkbox"/> Pumps-Submersible | <input type="checkbox"/> Septic Trucks | <input type="checkbox"/> Vanes |
| <input type="checkbox"/> Cable Machines | <input type="checkbox"/> Hydroexcavation | <input type="checkbox"/> Portable Toilets | <input type="checkbox"/> Pumps-Vacuum | <input type="checkbox"/> Service/Repair | <input type="checkbox"/> Vehicle Tracking |
| <input type="checkbox"/> Computer Software | <input type="checkbox"/> Jetters-Trailer | <input type="checkbox"/> Portable Toilet Tanks | <input type="checkbox"/> Pumps - Washdown | <input type="checkbox"/> Slide-In Units | <input type="checkbox"/> Wanted |
| <input type="checkbox"/> Dewatering | <input type="checkbox"/> Jetters-Truck | <input type="checkbox"/> Portable Toilet Trailers | <input type="checkbox"/> Pumps-Water | <input type="checkbox"/> Sludge Applicators | <input type="checkbox"/> Wastewater Transfer |
| <input type="checkbox"/> Drainfield Restoration | <input type="checkbox"/> Jet Vacs | <input type="checkbox"/> Portable Toilet Trucks | <input type="checkbox"/> Rodding Machines | <input type="checkbox"/> Tanks | <input type="checkbox"/> Waterblasting |
| <input type="checkbox"/> Drain/Sewer Cleaning Equip. | <input type="checkbox"/> Lease Financing | <input type="checkbox"/> Positions Available | <input type="checkbox"/> Roll-Off Containers | <input type="checkbox"/> Tools | |

CHOOSE THE PUBLICATION(S): (Deadlines are for the month preceding issue)

- | | | |
|---|---|--|
| <input type="checkbox"/> CLEANER
Deadline: 1st of the Month | <input type="checkbox"/> PUMPER
Deadline: 10th of the Month | <input type="checkbox"/> PRO
Deadline: 17th of the Month |
| <input type="checkbox"/> MUNICIPAL SEWER & WATER
Deadline: 1st of the Month | <input type="checkbox"/> ONSITE INSTALLER
Deadline: 17th of the Month | |

CLASSIFIED AD RATE:

\$1.00 per word, per month, with a 20-word minimum or \$20.
[\$1.00 extra per bold word (key words only)]

ADVANCE PAYMENT REQUIRED:

No billing for classified ads. Payment must be received in advance before publishing.

CALCULATE THE AMOUNT DUE:

_____ words X \$1.00 = _____ X _____ Publications X _____ Months = \$ _____
(\$20 minimum) # of publications checked above # of months to run the ad Total Amount Due

(Example: 25-wd. ad x \$1.00 per word = \$25.00;
\$25.00 x 2 publications [Pumper & Pro] = \$50.00;
\$50.00 x 2 months to run the ad = \$100.00 Total)

FILL IN COMPANY AND PAYMENT INFO:

COMPANY NAME: _____
 ADDRESS: _____ PHONE: _____
 CITY: _____ STATE: _____ ZIP: _____

MAIL this completed form with payment to:
COLE Publishing Inc., PO Box 220, Three Lakes, WI 54562

FAX this completed form to: **715-546-3786**

ONLINE forms at: www.cleaner.com
www.pumper.com
www.promonthly.com
www.onsiteinstaller.com
www.mswmag.com

QUESTIONS: CALL 1-800-257-7222

PLEASE FILL OUT CREDIT CARD INFORMATION COMPLETELY INCLUDING V-CODE (3-DIGIT NUMBER FOUND BY YOUR SIGNATURE)

CREDIT CARD NO.: _____ V-CODE: _____ EXP. DATE: _____
 CARDHOLDER NAME: _____ PHONE: _____



The Clear Choice!

effluent filters

POLYLOK[™] Inc.

BEST
TECHNOLOGY



Zabel[®]
A Division of Polylok Inc.



See why we consistently beat the competition!
Our filters...

- 1 Cannot be installed incorrectly.
- 2 Will not allow direct bypass.
- 3 Have a patented Shut-Off Ball that prevents solids from leaving the tank during servicing.
- 4 Have a unique design that prevents premature clogging.
- 5 Are rated for 800 GPD to 10,000 GPD.
- 6 Accept Smart Filter[®] Alarm to notify homeowner when the filter needs servicing.
- 7 Are ideal for septic, grease traps and advanced treatment systems.

Filters play a critical role in protecting the septic system leach field. To ensure your system is designed and protected properly, insist on Polylok and Zabel Filters. We have been the Clear Choice since 1959!

See our complete line of Effluent Filters at www.polylok.com



Zabel[®]
A Division of Polylok Inc.

BEST
TECHNOLOGY

POLYLOK[™] Inc.

Innovations in Precast, Drainage & Wastewater Products



Made In The U.S.A.

3 Fairfield Blvd,
Wallingford, Connecticut 06492
1-800-701-3942 Fax: 203-284-8514
email: sales@polylok.com
Web site: www.polylok.com

INNOVATIVE PRODUCTS ~ KNOWLEDGEABLE PEOPLE



Bravo™

Legacy™

Sanistand™



Limited Time!
Special Financing on all
PolyJohn Products.
Visit www.polyjohn.com
for Details!

800-292-1305

THERE WHEN YOU NEED US!

www.polyjohn.com

PRESVAC

DESIGNED AND BUILT FOR PERFORMANCE

Bright Finish Aluminum Tanks

for the Septic Pumping Industry...
Standard tank models from
2,000 gallons to 5,000 gallons.



Hydro-Trencher

5300 CFM air flow/28" HG vacuum with 8" hydraulic actuated boom, 3000 U.S. gal. stainless debris tank, 1000 U.S. gal. stainless water tank, 9 G.P.M. water pump with pressures to 5800 p.s.i.

Powervac 5300 for Wet/Dry Operation

5300 CFM air flow/28" HG vacuum,
Dump chutes extended to rear of truck,
Stainless steel 316, DOT 407/412



Liquid Truck - DOT 407/412

Designed for industrial liquid applications

PRESVAC

4131 Morris Drive
Burlington, Ontario, Canada L7L 5L5
Fax: 905-681-0411

Nationwide Sales & Service
905-637-2353 • 800-387-7763
www.presvac.com