

Special Issue: **PORTABLE SANITATION**

DEDICATED TO THE LIQUID WASTE INDUSTRY

# Pumper

April 2009 www.pumper.com \$5.00

## YANKEE Ingenuity

Practical growth is the rule  
for Vermont's P & P Septic

PAGE 36

**NEW TECHNOLOGY AT THE  
PUMPER & CLEANER EXPO**

PAGE 44

PPSTD STD  
U.S. POSTAGE  
PAID  
COLE  
PUBLISHING

CHANGE SERVICE REQUESTED

COLE PUBLISHING INC.  
1720 MAPLE LAKE DAM RD., PO BOX 220  
THREE LAKES WI 54982

# GOT AN EMERGENCY?



## CALL THE DOCTOR!

**20** New Trucks In Stock!

- Trucks
- Tanks
- Parts
- Service
- Pumps

### RESTROOM & SEPTIC

**TRUCK DOCTOR**  
800-328-3332

*Speak Directly With Our Experts About A  
Replacement Truck, Parts Or Advice On Repairs.*



[www.satelliteindustries.com](http://www.satelliteindustries.com)



*Imagine The Possibilities*

Get Ready for Spring with  
**Masport**<sup>®</sup>

**SPRING INTO  
ACTION!**

5.5 HP  
to  
24 HP



Masport Engine Driven  
Systems



Reduce oil  
carry over  
with Masport  
Oil  
Separators

Protect your pump  
with Quality Masport  
Components.



HXL4V  
Plug & Play  
System



165 CFM

The Leader in Portable  
Toilet Pumping!

**PUMPER|SCENT**<sup>™</sup>



Eliminate  
Odors with  
Pumperscent!

Toll Free: 1-800-228-4510

[www.masportpump.com](http://www.masportpump.com)



**Ask us** how the Sanitation Station can make you **money.**

~~Capital Outlay~~ = 



**Sanitation Station** is a Commercial Quality Running Water Restroom great for construction projects that can:

- Boost your cash flow immediately
- Allow you to have No out of pocket expense
- Be moved throughout the jobsite to meet the manpower requirements
- We provide the Marketing Material & Sales Assistance

*Once these units are on the Jobsite the revenue stream starts flowing...*

**DROP BOX** Custom Modification Specialist

888-388-7768 • 740-532-7822  
www.dropboxinc.com  
rmitchell@dropboxinc.com

# CAPITAL RUBBER CORP

Get Connected.

## WEATHERFLEX EPDM

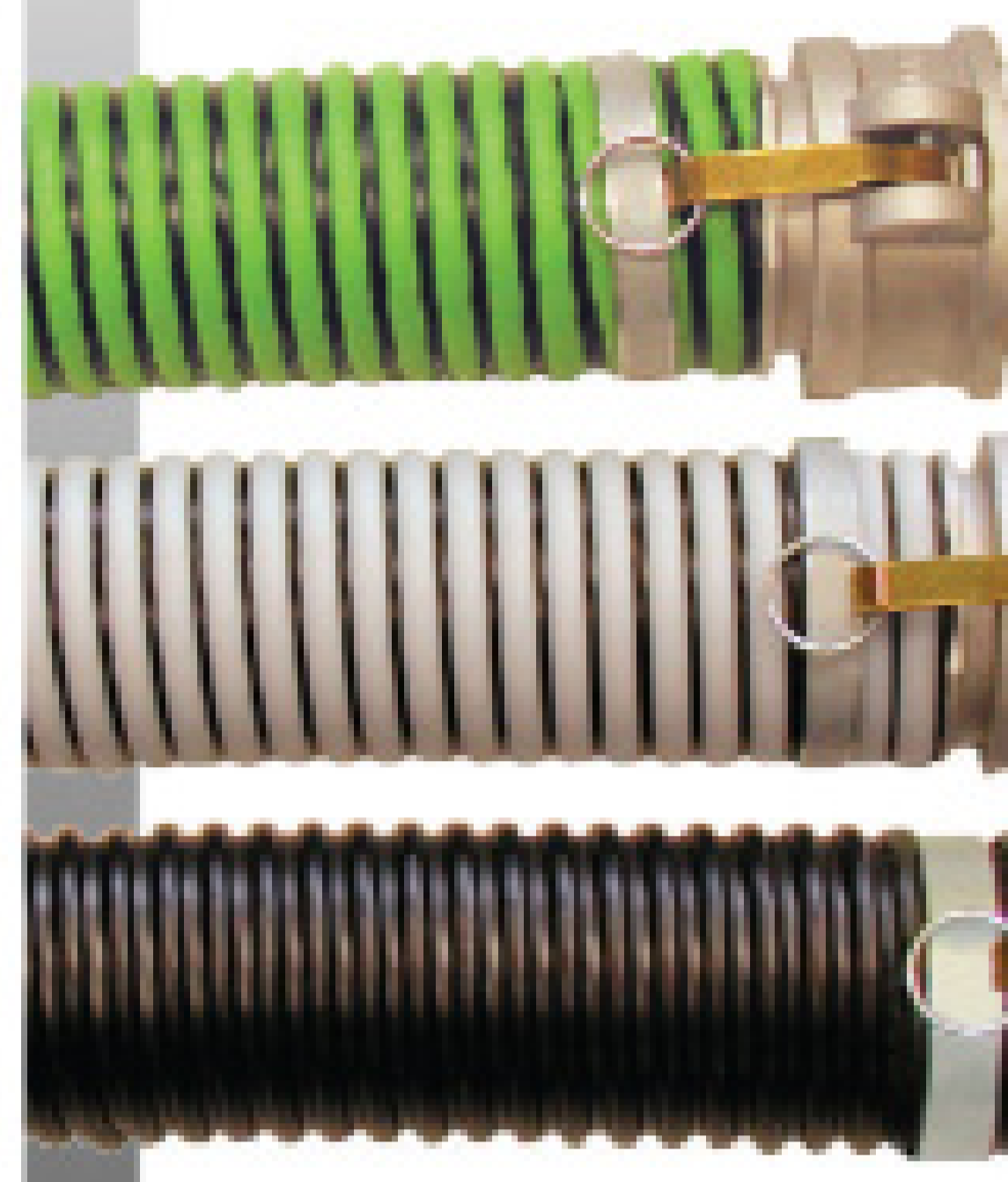

3" X 25 FT \$ 102.50  
3" X 33 FT \$ 129.50  
4" X 25 FT \$ 165.00

**COUPLINGS INCLUDED!**

### BULK HOSE SPECIAL!

2" X 50 FT	4" X 50 FT
\$102.50	\$287.50
\$89.00	\$245.00

## POWER BOOSTER

INCREASE VERTICAL LIFT



**INCREASE:**

- **CAPABILITY**
- **POSSIBILITY**
- **PROFITABILITY**

The unique patent-proven Power Booster design allows you to harness the power of a compressed air or water source to significantly increase the performance of a vacuum truck!

### PUT IT TO THE TEST



**CALL TODAY FOR A  
NEW FULL-COLOR  
2009 CATALOG  
AND THE  
POWER BOOSTER  
DEMO DVD!**

845 N DILLON DRIVE  
WOOD DALE, IL 60191

**(800) 258-3000**



**WWW.CAPITALRUBBERCORP.COM**

# Lenzyme

Solutions for all Waste & Grease Problems



## NEW Drainfield Business Builder



**BEST PACKAGING - BEST PRODUCTS - BEST PRICE**



Discover Marketing Secrets to More Pump-Outs

**1-800-223-3083**

Call Today for Your **FREE** Sample



Trap-Cleer

Lenzyme

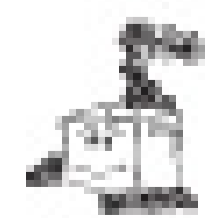

# HOUSE OF IMPORTS **TRUCK SALES**

▶▶ SINCE 1947

FAX: 305.691.4779

**CALL ANGEL AT:**  
**786.258.3384**  
OR  
**305.691.4778**

▶▶▶ WWW.HOUSE-OF-IMPORTS.COM

## THANK YOU FOR VISITING US AT THE PUMPER & CLEANER EXPO!

**NOW AVAILABLE**



**2002 INTERNATIONAL**  
3600 GAL, 450 HP CUMMINS

**NOW AVAILABLE**



**2003 INTERNATIONAL**  
2500 GAL, 350 HP, 357 CFM PUMP  
**\$59,500**

**2001 VOLVO**

3600 GAL, 370 HP CUMMINS  
**\$65,000**

**SOLD AT THE EXPO**



**2005 PETERBILT 379**  
THANKS TO TOM TERRELL  
SOLD 2 TIMES AT THE EXPO!



**2001 INTERNATIONAL**  
3600 GAL, 370 HP CUMMINS  
**\$65,000**



**2004 PETERBILT**  
5000 GAL, IN PROGRESS

**SOLD AT THE EXPO**



**2000 FREIGHTLINER**  
THANKS TO TEMPLETON EXCAVATING

**SOLD AT THE EXPO**



**2006 PETERBILT 379**  
THANKS TO BOB OSBORND

**SOLD AT THE EXPO**



**2005 MACK**  
THANKS TO GERALDO MACIA  
EXPORT TO MEXICO

**100,000 MILE LIMITED FACTORY WARRANTY**

▶ DELIVERY ▶ EXPORT ▶ PUMP WARRANTY: 1 YEAR ▶ TANK WARRANTY: 5 YEARS

## ARTICLES

### 36 Yankee Ingenuity

- Ken Wysocky

**On the cover:** Derek Pratt of P & P Septic in Williston, Vt., has seen his company grow from primarily a septic pumping business to offer portable restrooms, drain cleaning and excavating. On the cover, Pratt is shown removing a septic tank lid. (Photo by Andy Duback).

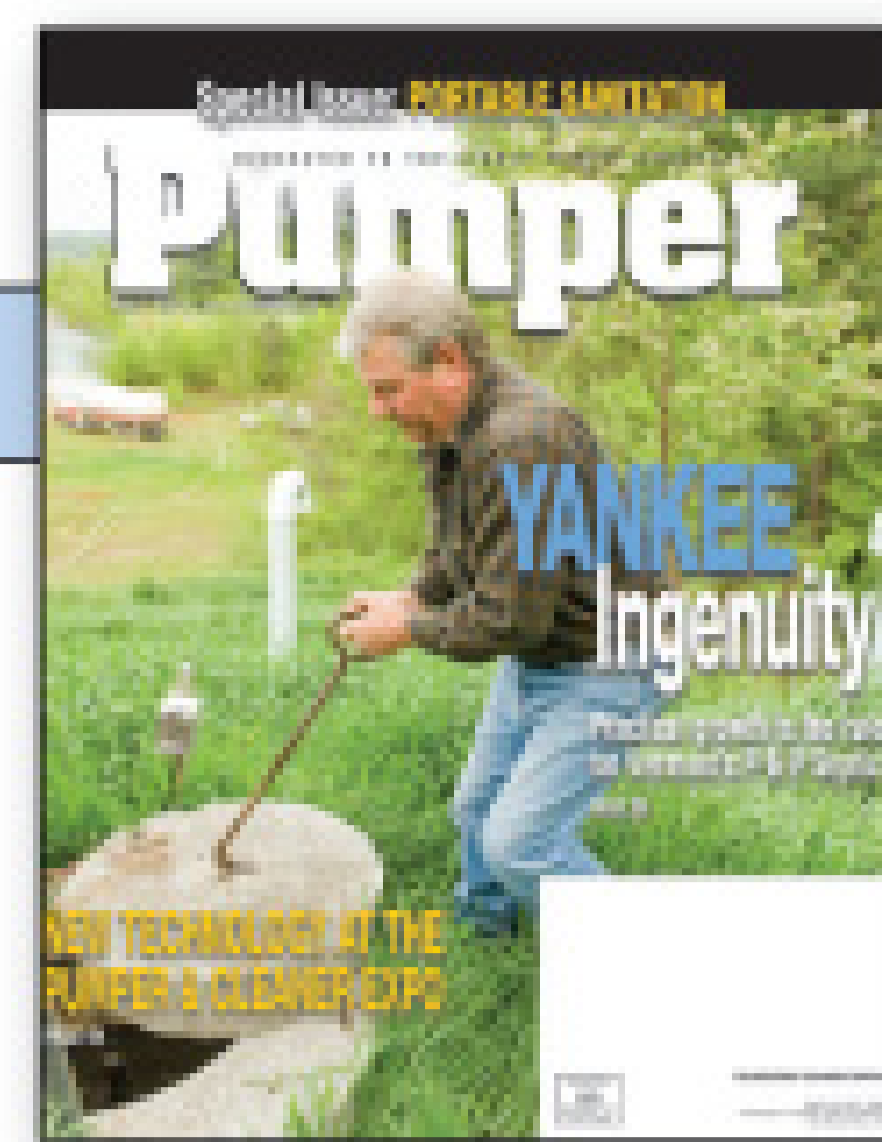

### 14 Reading Between the Lines: The Place to Be

Dedicated contractors say learning opportunities abound at the Pumper & Cleaner Expo.  
- Jim Kneiszel

### 22 Building the Business: Recruiting Summer Helpers

Even in a tough economy, temporary teen workers are an effective tool to handle the seasonal rush of special event portable sanitation work.  
- Ken Whiting

### 28 Rules and Regs: Connecticut Mulls Septic System Rule Changes

- Scottie Dayton

### 44 As Seen at the Expo

Latest liquid waste technology takes center stage at the Pumper & Cleaner Expo.  
- Jim Kneiszel and Ed Wodalski

### 54 Good Times in a Tough Economy

Attentive management and smart diversification provide a recession-proof growth formula for California's Knight's Pumping and Portables.  
- Mary Shafer

### 64 After Hours: On the Case

Tex-Mex border portable restroom contractor balances sanitation services and bail bonds business.  
- Sharon Verbeten

### 76 Overheard Online: Lighten My Load

Online posters reassure a pumper about his company's switch to aluminum vacuum tanks.

### 94 Class Acts

NAWT meeting at the Pumper & Cleaner Expo is the stage for major industry awards.  
- Jim Kneiszel

### 100 Legal Advisor: Your Employee's First Day

Whether you're hiring for the first time or adding to staff, it pays to be up-to-date with the legalities of bringing people on board.  
- Fred S. Steingold

### 104 Pumper Interview: Mr. Smith Takes the Wheel

Harold Smith developed the Five Keys of Space Cushion Driving, then dedicated his life to preaching collision avoidance.  
- Jim Kneiszel

## REGULAR FEATURES

### 70 Money Manager: Cash Flow is King

Especially in the cyclical business of portable sanitation, a healthy financial reserve or a solid line of credit will cover expenses and keep the warehouse stocked.  
- John Camphouse

### 82 Reader Pipelines: Bullish on Portable Sanitation

Despite an economic slowdown, some contractors look to bolster their restroom inventories.  
- Mary Shafer

### 88 Septic System Answer Man: Sludge 101

Understanding the solid and scum layers in a septic tank will help you explain necessary system maintenance to reluctant customers.  
- Roger E. Machmeier, Ph.D

### 102 Classy Truck of the Month

We feature Blocker's Septic Service Inc., Yulee, Fla.

### 118 Association News; Training and Education; Calendar

### 120 Industry News

## Coming in May

### Special Issue: ONSITE SEPTIC SYSTEM

- **After Hours:** Pumper and javelin-throwing son attend Olympics
- **Contractor Profile:** A Massachusetts pumper builds business for eventual retirement sale

# Pumper

DEDICATED TO THE LIQUID WASTE INDUSTRY

[www.pumper.com](http://www.pumper.com)

Published monthly by

 COLE publishing

Celebrating 30 years of publishing.  
1979-2009

COLE Publishing Inc.  
1720 Maple Lake Dam Rd.  
PO Box 220  
Three Lakes WI 54562

© Copyright 2009 COLE Publishing Inc.  
No part may be reproduced without  
permission of the publisher

In U.S. or Canada call toll-free 800-257-7222  
Elsewhere call 715-546-3346  
E-mail: [info@pumper.com](mailto:info@pumper.com)  
Web site: <http://www.pumper.com>  
Fax: 715-546-3786

Office hours 7:30 a.m. - 5:00 p.m.  
Central Time, Monday - Friday

**SUBSCRIPTION INFORMATION:** A one year (12 issue) subscription to *Pumper* in the contiguous 48 U.S. states costs \$16 (24 issues for \$26; 36 issues for \$36). Subscriptions to Canada or Mexico cost \$28 per year (24 issues for \$54). Subscriptions to all other foreign countries cost \$82 per year. Subscribers are guaranteed monthly delivery of the magazine. To subscribe, send company name, mailing address, phone number and check or money order (U.S. funds payable to COLE Publishing Inc.) to the address above. MasterCard, VISA and Discover are also accepted. Supply credit card information with your subscription order.

Our subscriber list is occasionally made available to carefully selected companies whose products or services may be of interest to you. Your privacy is important to us. If you prefer not to be a part of these lists, please contact Kayla at [kaylaw@colepublishing.com](mailto:kaylaw@colepublishing.com).

**CLASSIFIED ADVERTISING:** RATE: \$1.00 per word, per month. Minimum of 20 words or \$20. All classified advertising must be PAID IN ADVANCE. **DEADLINE:** Classifieds must be received by the tenth of the month for insertion in the next month's edition. **PHONE-IN ADS ARE NOT ACCEPTED.** Ads may be faxed only when charging to MasterCard, VISA or Discover. Please supply all credit card information with faxed ads. Be sure to include your phone number (with area code) in your ad. Make checks payable to COLE Publishing Inc. and mail with classified ad to the address above. **CLASSIFIED ADVERTISING APPEARS NATION-WIDE AND ON THE INTERNET.** Not responsible for errors beyond first insertion.

**DISPLAY ADVERTISING:** Call 800-994-7990 and ask for Jim, Kim, Winnie or Phil. Publisher reserves the right to reject advertising, which in its opinion is misleading, unfair or incompatible with the character of the publication.

**CIRCULATION:** Circulation averages 26,071 copies per month. This figure includes all circulation regions (nationwide) and international distribution.



**PUMPER & CLEANER  
ENVIRONMENTAL  
EXPO  
INTERNATIONAL**

Education Day:  
February 24, 2010

Exhibits Open:  
February 25-27, 2010

Kentucky Exposition  
Center  
Louisville, Kentucky  
[www.pumpershow.com](http://www.pumpershow.com)



# moro PUMPS

"Over 50 years of service and here to stay!"

Ask for a quality Moro pump from your truck builder, or call us for the dealer nearest you.

Pittsburgh, PA . 1-800-383-6304 . fax 412-269-4172 . www.morousaeast.com . moroeast@attglobal.net  
St. Louis, MO . 1-866-383-6304, 636.584.8844 . fax 636-583-2044 . www.morousaeast.com . moro@charter.net

## The **NEW** Moro Vacuum Pumps from **MORO USA**

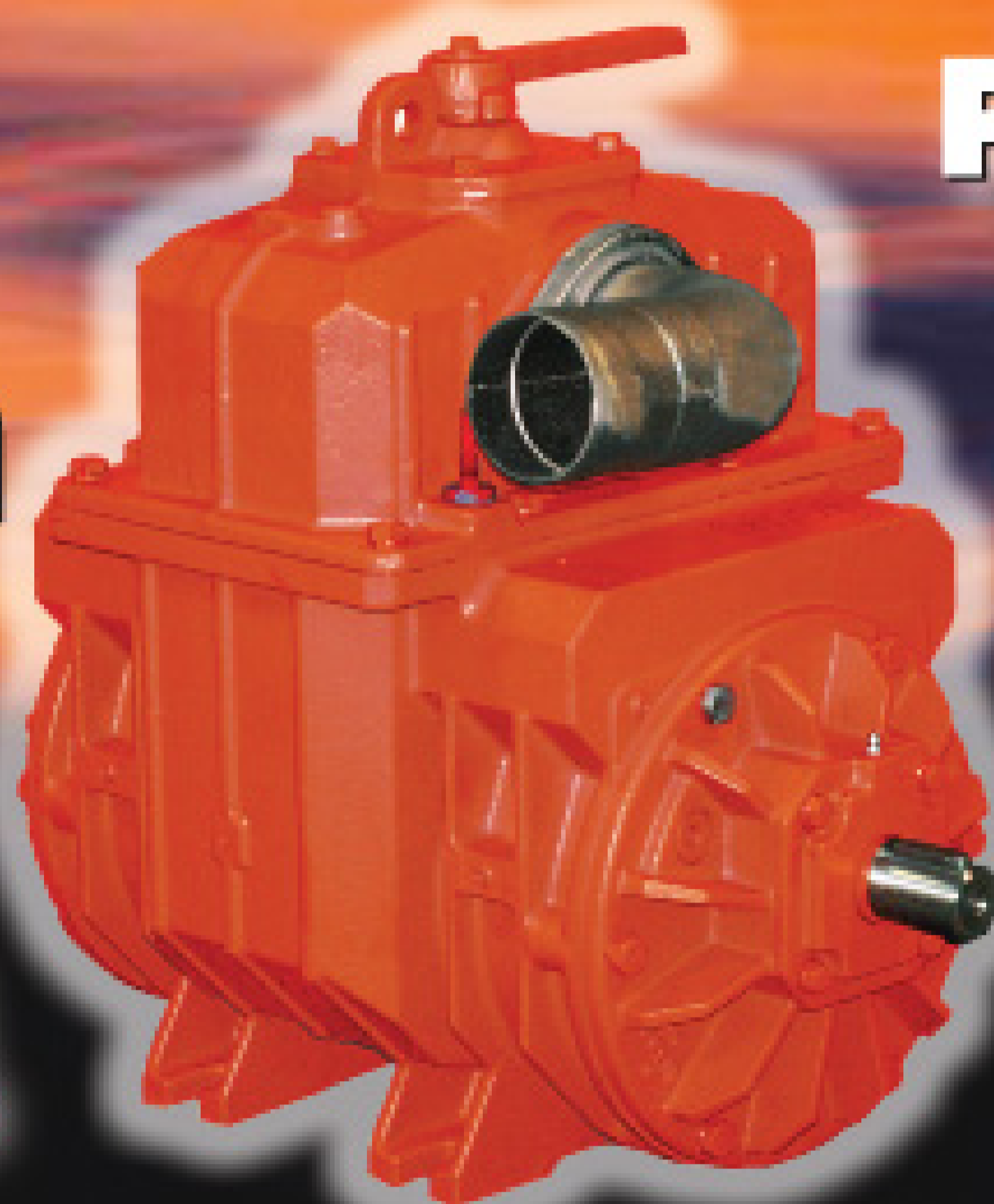

### PM60A

233 cfm

### PM70A

300 cfm

### PM80

379 cfm

## Isn't it time to UPGRADE to a MORO?

## Complete Right Angle Packages

Pumps available from 176-1642 cfm

Completely Assembled



230 cfm

### M10



### PM80

350 cfm



460 cfm

### PM100

## DC-STAINLESS Washdown Pump

**NO COMPARISON**



NO more  
RUSTY  
water!

OUTPERFORMS  
the Burk's  
cast iron  
DC-10!

NO More  
FROZEN  
pump!



316 Stainless Steel Mounting  
Brackets, Pump Head & Impeller

## Quality RIV Components In Stock — Ready for Shipment



## ACCU-LEVEL

### Accurate Tank Volume Measurement

No Balls • No Tubes • No Floats • No Worry!  
No Internal Tank Components

Get paid for what you pump!

Only pay for what you dump!



### Level Indicator

Factory calibrated, the general purpose indicator reads 0-100% of volume in gallons. A single push button allows users to scroll through their active channels.



### Pick-up Unit

The general purpose two-wire transmitter provides non-contact level measurement up to 32' and is ideally suited for challenging corrosive, coating or waste liquids.

# ADVERTISER index .....

April 2009

27th Trucks Inc. ....66

## A



Abbott Rubber Co. Inc. ....99



Abernethy Welding & Repair 99



Acro Trailer Company .....78  
Advance Pump & Equip. ....21  
AllGreen Mfg., LLC .....20  
Alpha Mobile Solutions .....74  
Ameri-Can Engineering .....24  
American Machine & Tool ....20  
Amthor International .....97  
Anchor Graphics Inc. ....93  
Aqua Ben Corp. ....97



Aqua-Zyme Disposal Sys. ....68



Arcan Enterprises Inc. ....84



ARMAL Inc. ....79



Armstrong Equip. ....13, 40, 80  
Art's Truck & Equipment .....58  
Atlanta Rubber & Hyd. ....68

## B

Badger Vacuum Trucks .....105  
Bandlock Corp. ....66  
Best Enterprises Inc. ....29  
Black Tie Manufacturing .....96  
Brenlin Co. Inc. ....30



Bright Technologies .....42

## C



Cam Spray .....50  
Cape Cod Biochemical .....42



Capital Rubber Corp. ....4  
Center Capital Corp. ....10

## C



Chandler Equipment Inc. 9, 11  
Chempace Corporation .....92



Clear Computing Inc. ....10



Comforts of Home Services 16  
ComVac Systems Inc. ....98



Crust Busters/Schmitz Bros.90

## D

Del Vel Chemical Co. ....105  
Denver Truck Sales .....24  
Dragon Products .....32-33  
Drop Box Inc. ....4

## E

Earth Friendly Chemicals ....16  
Ecological Laboratories ....28  
**ELASTEEL**  
American Marine  
Elastec/American Marine ....78  
EnviroTub .....20  
Erickson Tank & Pump .....74

## F



F. S. Solutions .....59  
Fergus Power Pump Inc. ....120  
Flats No More .....97



Flo Trend Inc. ....74  
FMI Truck Sales & Service ..96  
Frontier Technology .....30  
Fruitland Tool & Mfg. ....93

## G

Gamajet Cleaning Sys. ....75  
GapVax Inc. ....27  
Glendale Welding .....80  
Granite Leasing Co. ....90  
Green Way by PolyPortables 81

## H

Hampel Corp. ....53  
Hannay Reels .....100  
Horizon Information .....65

## H

House of Imports .....5  
Hull's Truck Bodies .....39

## I

Imperial Industries Inc. ....61

## J



J&J Chemical Co. ....25



JAG Mobile Solutions .....67  
James Wilbee Company .....24

## K

KeeVac Industries Inc. ....35  
Keith Huber Inc. ....30  
Kentucky Tank Inc. ....86  
Key Commercial Corp. ....98  
KMH Equipment Inc. ....72

## L

L.C. Tanks .....83  
L.M.T. Inc. ....40  
Lane's Vacuum Tank Inc. ....16



Lely Manufacturing Inc. ....52  
Lely Waste Solutions .....95



Lenzyme-Trap-Clear Inc. ....4  
Longhorn Tank & Trailer Inc. 58

## M

Magnets by Stamp Works ....22  
**Marsh**  
Marsh Industrial .....92



Masport Inc. ....3  
McKee Technologies Inc. ....26  
Michigan Vacuum Truck .....23  
Mid-Continent Truck Sales 112  
Mid-State Tank Co. Inc. 26, 50  
Milwaukee Rubber Prod. ....15



Moro USA East Inc. ....7

## N

National Vacuum Equip. ....31



NuConcepts .....58

## P



Pik Rite Inc. ....50  
PolyJohn Enterprises .....123  
Polylok Inc. ....122  
PolyPortables Inc. ....18-19  
Power Vac Inc. ....52



Pressure Lift Corp. ....34  
Presvac Systems Ltd. ....124



Prototek .....102

## R

RNI-Dalbo Trucking .....10  
Robinson Septic Service ....93  
RotoSolutions Inc. ....26  
Rush Refuse Systems .....69

## S

Satellite Industries Inc. 2, 62-63



Septic Services Inc. ....72  
Smithco Mfg. Inc. ....60  
Specialty B Sales .....90  
Spectrum Environmental .....97  
Standard Equipment Co. ....65  
Super Products LLC .....87  
Surco Products .....91  
Sweet Septic Systems Inc. ....52

## T



T&T Tools Inc. ....12  
Tank Truck Service & Sales 15



Tank Technologies & Supply Co. LLC  
TankTec .....17  
The Service Program .....76



Toico Industries Inc. ....101



Transport Truck Sales .....89



Transway Systems Inc. ....71  
TSF Company Inc. ....41  
TST, LLC .....86  
Tuf-Tite Inc. ....43

## V

V.E. Enterprises Inc. ....85  
Vac-Con Inc. ....51  
Vacutrux Limited .....49  
Vacuum Truck Rentals .....105



VAR Co. ....77

## W

Walex Products Co. ....73  
Wallenstein Pumps-Elmira ..60  
Water Cannon Inc. ....103  
Wee Engineer Inc. ....12



Wells Cargo COG .....84  
Westmoor Ltd. ....34  
Wilcox Truck Sales .....84  
Wittrock Enterprises .....42

**Classifieds** .....113  
**Marketplace** .....110  
**Truck Stop** .....106

## REGIONAL ADVERTISERS

### Midwest Supplement

(after page 98)

Engle Fabrication LLC .....7  
Heritage Truck Equipment ....8  
Liberty Financial Group .....2  
Marengo Fabricated Steel ....5  
Mid-State Truck Service .....5  
Milwaukee Rubber .....4  
Pat's Pump & Blower .....3  
Pierson Co. ....4  
Rider Vacuum Sales .....1  
Robertson Truck Sales .....7  
T-Line Equipment Inc. ....8  
V&H Inc. ....3  
Vacuum Sales Inc. ....2

### Eastern Supplement

(after page 98)

Andert Inc. ....8  
Chemisphere Inc. ....4  
Heritage Truck Equipment ....8  
Liberty Financial Group .....2  
Manchester Hose & Coupling .4  
Marengo Fabricated Steel ....5  
Pat's Pump & Blower .....3  
Truck Services of Virginia ....1  
TSI Tank Services Inc. ....5  
V&H Inc. ....3  
Vacuum Sales Inc. ....2, 7



# RAZOR-PAK LC420

Featuring the

## RAZOR-PAK MUFFLER

- Interchangeable Ports for Different Mounting Options
- 2 Access Ports for Easy Cleanout
- 500 CFM
- 2", 3" & 4" Size Available

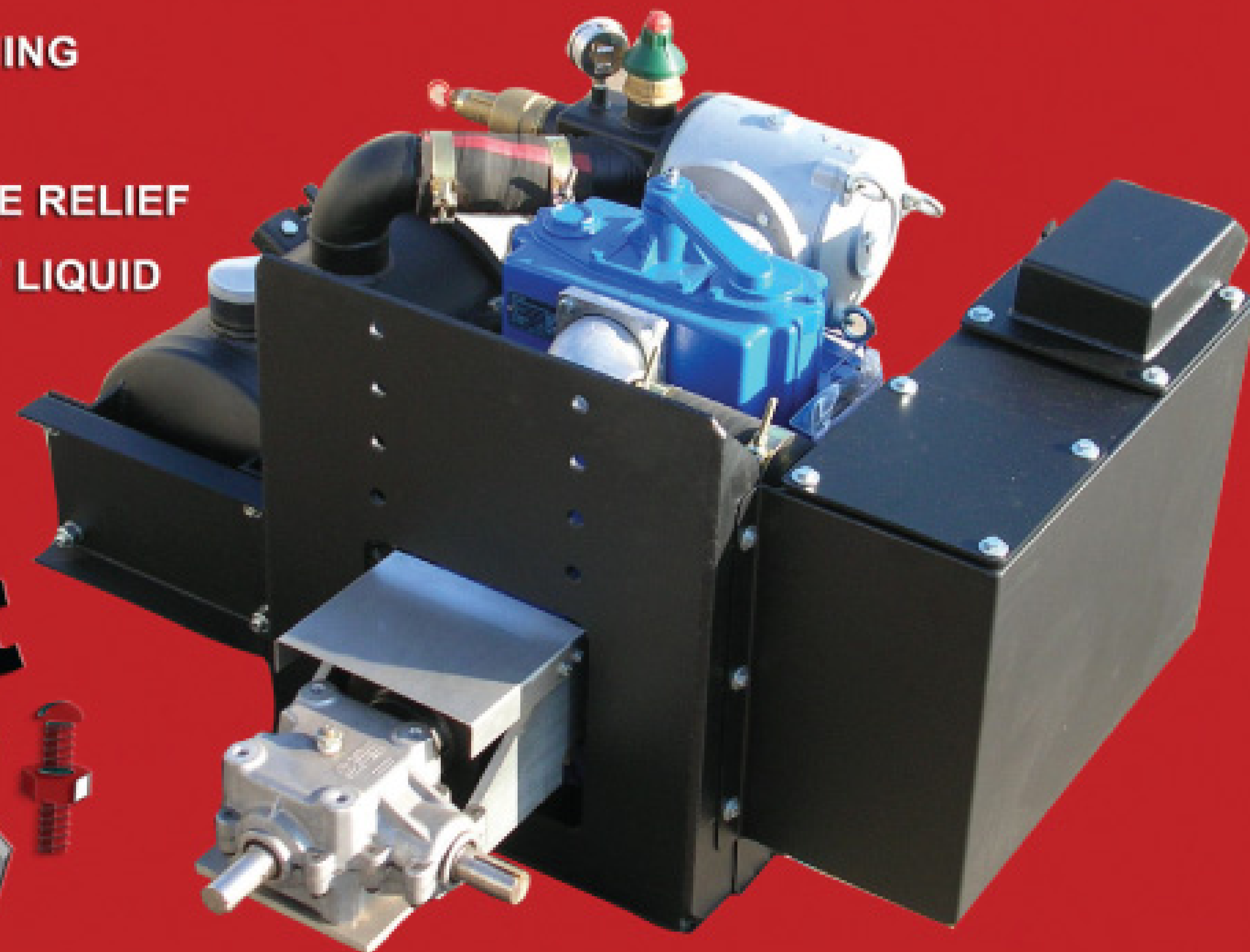
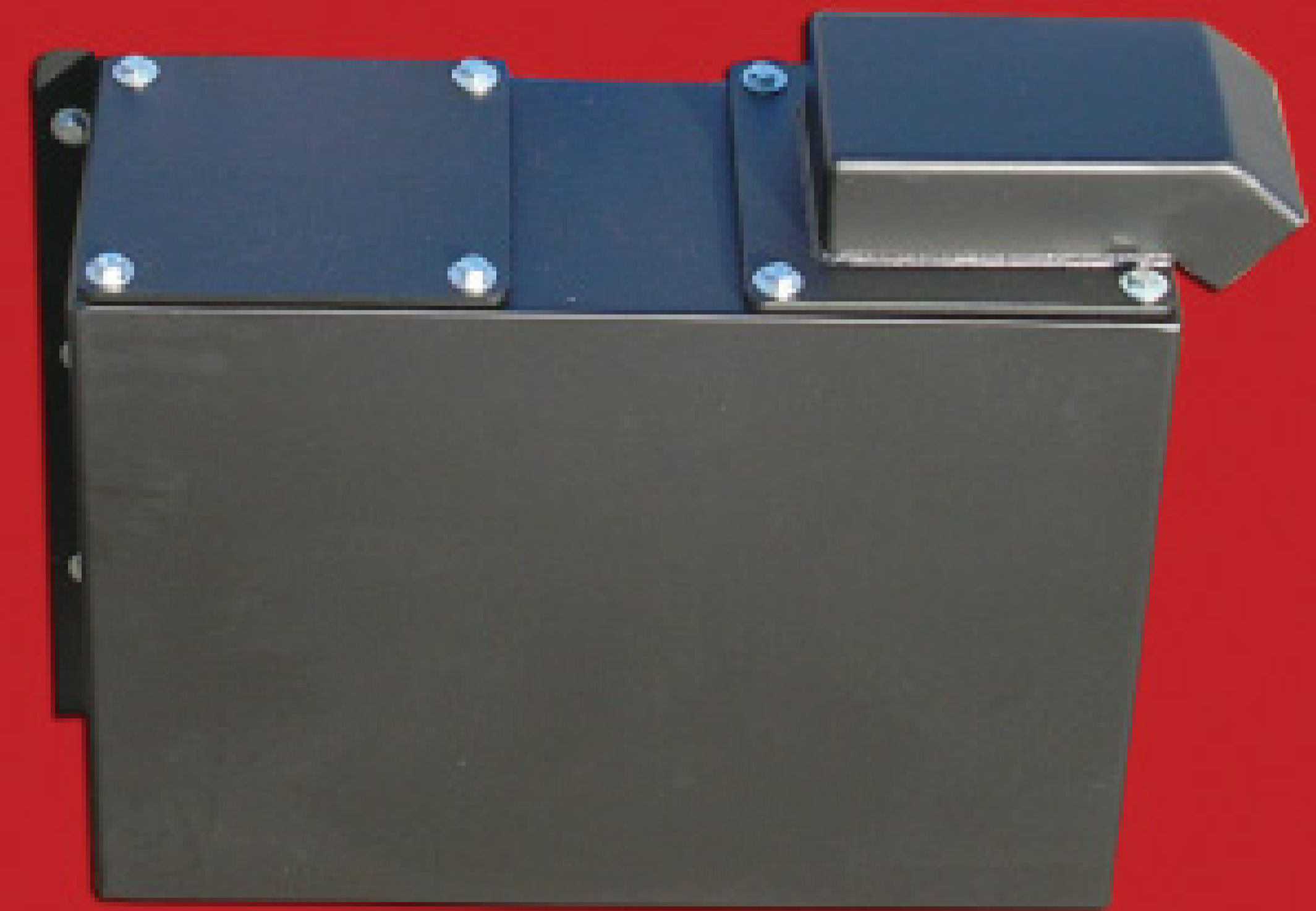

### Razor-Pak

- JUROP VACUUM PUMP
- PUMP MOUNTING STAND MADE OF 3/8" HEAVY DUTY STEEL
- ALUMINUM AUTO ALIGN BRACKET
- 3 SHAFT GEARBOX, 400 SERIES WITH 1 1/4" SHAFT
- 1 3/8" X 1 1/4" SIZE 9 PUMP COUPLING
- 10 GALLON HORIZONTAL SECONDARY WITH 3" OPENING
- FINAL FILTER 3" WITH "REUSABLE" 55 MESH FILTER
- VACUUM PRESSURE TREE WITH 2" BRASS PRESSURE RELIEF VALVE, 1 1/2" BRASS VACUUM RELIEF VALVE & 2 1/2" LIQUID FILLED VACUUM PRESSURE GAUGE
- NEW RAZOR-PAK MUFFLER
- POWDER COATING & ASSEMBLY

**Bolt  
-N-  
GO**



**Chandler  
Equipment, Inc.**

**800-342-0887**

[www.chandlerequipment.com](http://www.chandlerequipment.com)

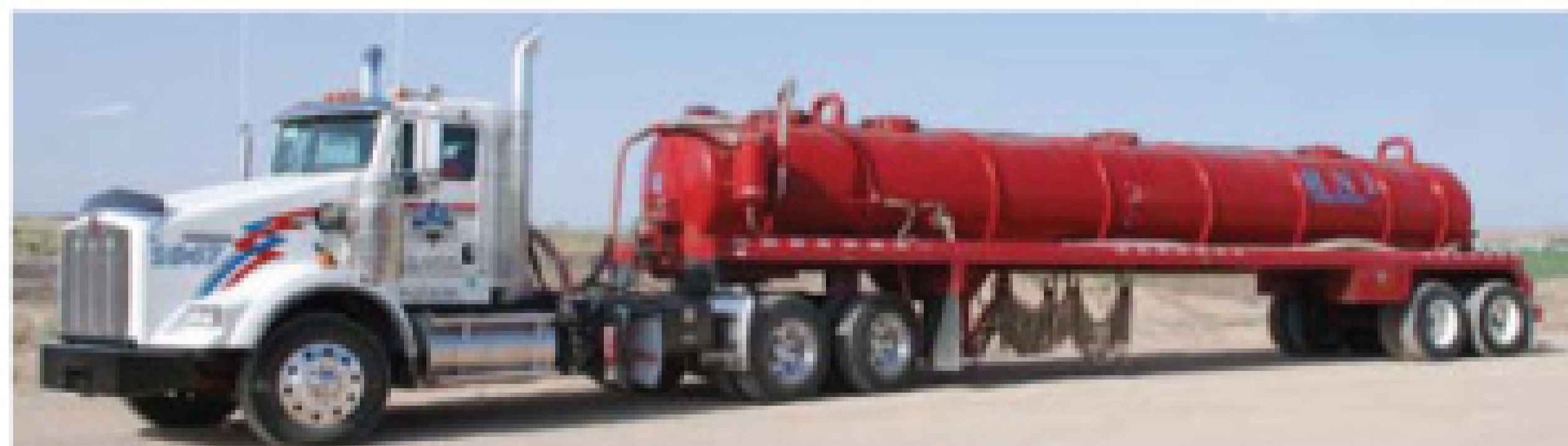

Your Specialists In Fluid Transportation and Storage



- 7,500 & 3,300 Gal Fluid Transport Trucks
- 21,000 gal Frac tanks
- Will Transport Tanks and Fluids To and From
- We Will Deliver To Any Location

**1-866-478-6803**

Email: roger@rniindustries.com

**CLEAR COMPUTING** *with* **INSIGHT**

**Total Activity Control Street Eagle GPS**



**GREEN MACHINE**

- **Bulk Email Invoicing**
- **On-Line Bill Payment**

**Increase Profits • Cut Costs • Improve Productivity**

- **Work Orders with Annotated Map**
- **Calendar Dispatch**
- **In-Vehicle Garmin**
- **TACTrackerPRO**
- **Your Company, Your Way, Anywhere, Anytime**



- **Lease or Buy**
- **FREE Trial**

**Clear Computing**  
(888) 332-5327

[www.clearcomputing.com](http://www.clearcomputing.com)

**Insight USA**

(301) 866-1990 x201

[www.mds-inc.com](http://www.mds-inc.com)

# “We invest in People”



Call **800 • 344 • 2224**

and ask for Bob Marino

- **New and Used Equipment Financing**
- **Competitive Rates and Terms**
- **No Hidden Cost/Simple Application Process**

- > Portable Restrooms
- > Industrial Vac Trucks
- > Service Vehicles
- > Jetties
- > Video Inspection

**[www.CenterCapitalCorp.com](http://www.CenterCapitalCorp.com)**

**Celebrating 26 Years of Loyal Service**

\*Center Capital Corporation is a subsidiary of Webster Bank, N.A., Member FDIC  
All financing programs are subject to credit approval.

## **Pumper Show Winners**

**\$500 Winner:** Bradie Smith of Premium Hydro Solutions, LLC (Alpena, MI)

**\$300 Winner:** Bill Hensley of City of Sherwood (Sherwood, AR)

**\$200 Winner:** Mike Stocking of Stocking Stalls Septic Tank Service (Cherry Valley, NY)



Don't be amazed  
Our horizons are only a little bit wider

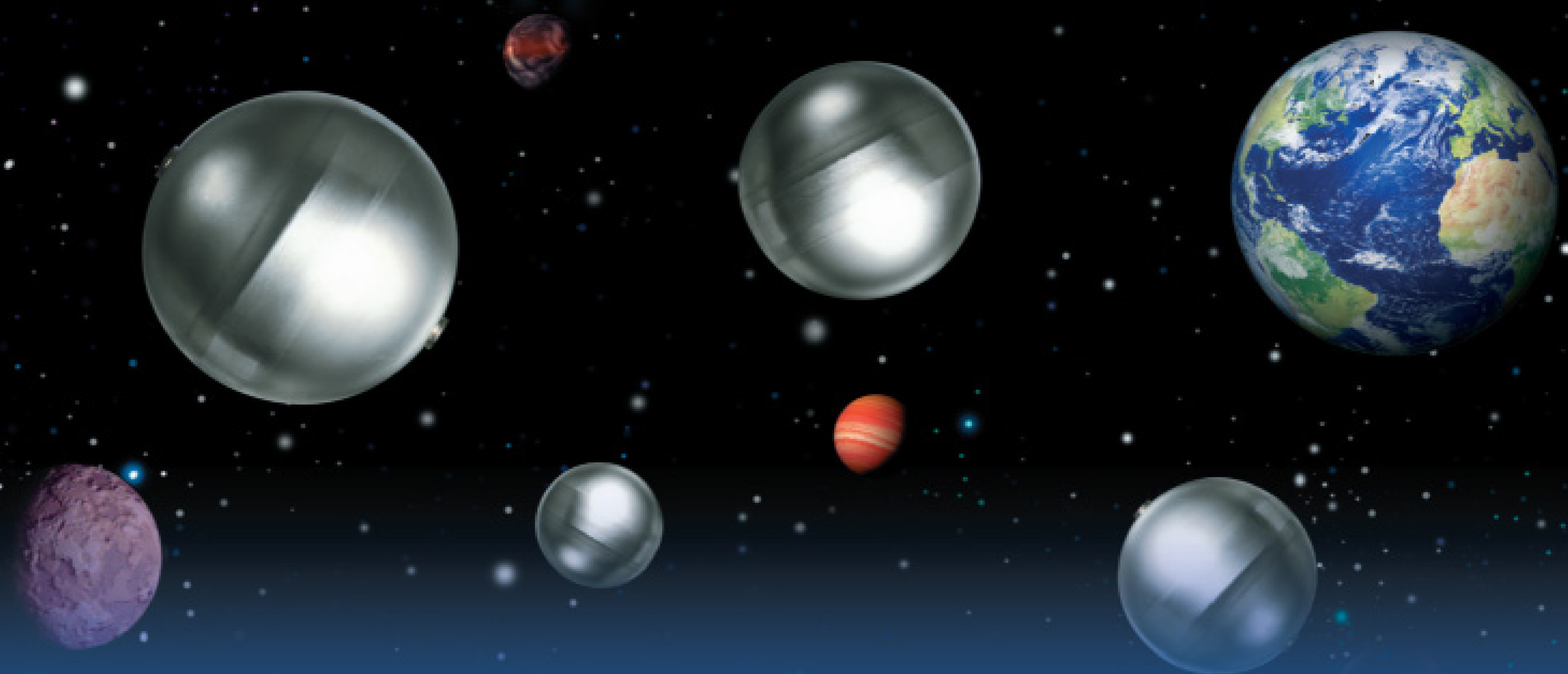

**Floating stainless steel balls**  
Strong, unassailable, accurate

- Available in AISI 304 and AISI 316
- Excellent spherical model
- Polished TIG welding

**NEW**

- DN 100
- DN 150
- DN 200

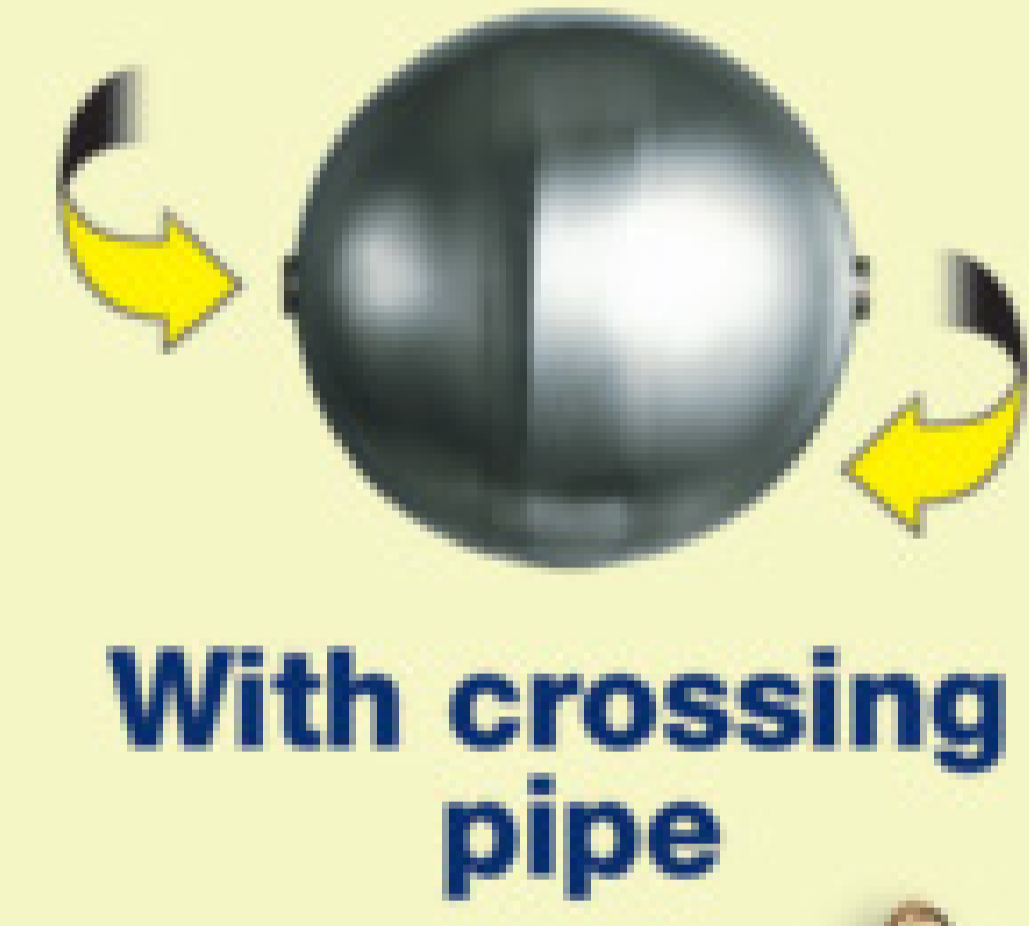

**METALTECNICA** s.r.l.

[www.metaltecnicazanolo.com](http://www.metaltecnicazanolo.com)



**Chandler**  
Equipment, Inc.

Toll Free 1-800-342-0887  
[www.chandlerequipment.com](http://www.chandlerequipment.com)

USA DISTRIBUTORS

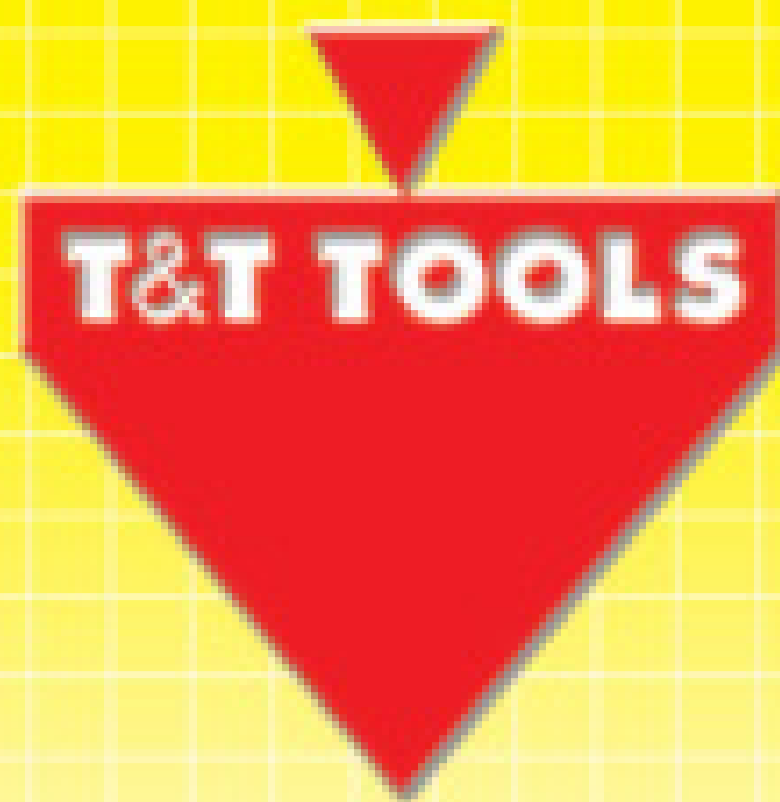

# T&T Tools, Inc.

Fax: 800.521.3260  
Email: sales@tandttools.com

# 800.521.6893

www.MightyProbe.com



### HOOKS...

- > Several different styles of heat-treated hooks are available
- > Top Poppers are great to open manhole covers
- > The Handy Hooks allow two handed use

### PROBES...

- > Insulated, standard, and specialty soil probes
- > Metal shaft sizes: 3/8" round, 3/8" hex, or 7/16" hex
- > Replaceable tips are threaded on and hardened
- > A "slide" allows the handle to pound the shaft into the ground

# Wee Engineer

WITH IMAGINATION

## Call us for a quote...

# WE



**2000 Ford F-650** (under CDL) Turbo diesel, 210 HP, 6-speed manual, 164,000 miles, PS/AC, 25,950 GVW. **One-yr-old 1500-gallon tank**, carbon steel, and a **One-yr-old MEC 8000 Battioni 240 CFM vacuum pump**, gearbox driven, automatic oiler, **NEW 100-gallon fresh water tank** with 5-gpm demand pump. **NEW** hose reel Price ..... **\$36,500**



**Reduced \$110,875**  
**New 2008 International 7400** MaxxForce DT, 300 HP, Allison 5-speed automatic, **New 3600-gallon Progress aluminum tank**, full length aluminum hose trays and a **New Masport HXL 400 CFM vacuum pump**, water-cooled. Price ..... **\$112,875.00**



**Wee Vac The Wee Vac** fits through a standard doorway and can pump up to 45 gallons of grease at a time. It has a female cam-lock so it can be downloaded into your truck. It features a 110 volt vacuum pump. Price: **\$1,240**



**SPRING MOUNTS** decrease fatigue on your tank frame, mounts to most tanks, Easy bolt or weld on style, Heavy-duty stress relieved springs. **Mounts with springs...\$82.00**  
**Springs alone .....\$11.00 each**



(Truck shown is not exact truck.)  
**2003 Freightliner FL70**, Cat 230 HP, 168,000 miles, Allison automatic transmission, 26,000 GVW, under CDL, PS/AC, Air brakes. **New 2200 gallon, carbon steel vacuum tank**, 3" side inlet, 4" outlet, Rear work lights, 20" top primary, 20" Rear man-way, 5-gallon secondary, Aluminum toolbox. **Battioni MEC 8000 vacuum pump**, 240 CFM, gearbox driven, Hot shift PTO Price: ..... **\$37,500**

P.O. Box 39 Dayton, IN 47941 Toll-Free: **877-296-2555** Phone: **765-296-2027** Fax: **765-296-3027**  
**www.wee-engineer.com**

# NO COMPROMISE



**Masport**  
HXL400WV

**At Armstrong Equipment,** we believe life and business require certain compromises, but not on those things on which your business and family depend. A beautiful, new and shiny vacuum truck with a burned out pump is nothing more than uncomfortable transportation at four miles per gallon.

Your customers depend on you! Your employees depend on you! Your family depends on you!

We think you should be able to depend on **us!** That is why we sell the most dependable vacuum pumps, parts, valves and tank components available. When it comes to quality and reliability in the tools that make your business successful, there should be:

## "No Compromise."

We proudly stock Masport, Jurop, NVE, Fruitland and G-D Wittig vacuum pumps, Sutorbilt blowers, Garnet Instruments SeeLevel gauges, Clearflow Heavy Duty valves and most other vacuum truck components and accessories. We can also provide replacement pumps and repair kits for most major brands. For more information call us toll free at **800-699-7557**.

## ARMSTRONG EQUIPMENT INC.

**800-699-7557**

11200 Greenstone Ave. • Santa Fe Springs, CA 90670

562-944-0404 • Fax: 562-944-3636

[www.vacpump.com](http://www.vacpump.com)

**FRUITLAND**  
RCF500F



**Wittig**  
RFL100



**Sutorbilt**

4M



**NVE**  
506

**Jurop**  
R260

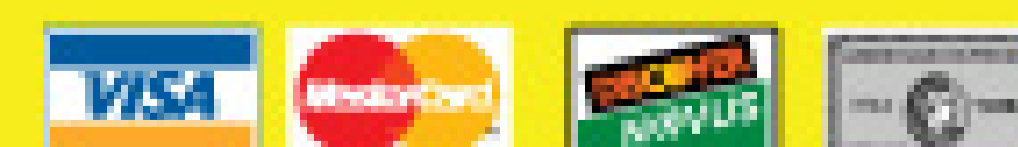

# THE PLACE TO BE

**Dedicated contractors say learning opportunities abound at the Pumper & Cleaner Expo**

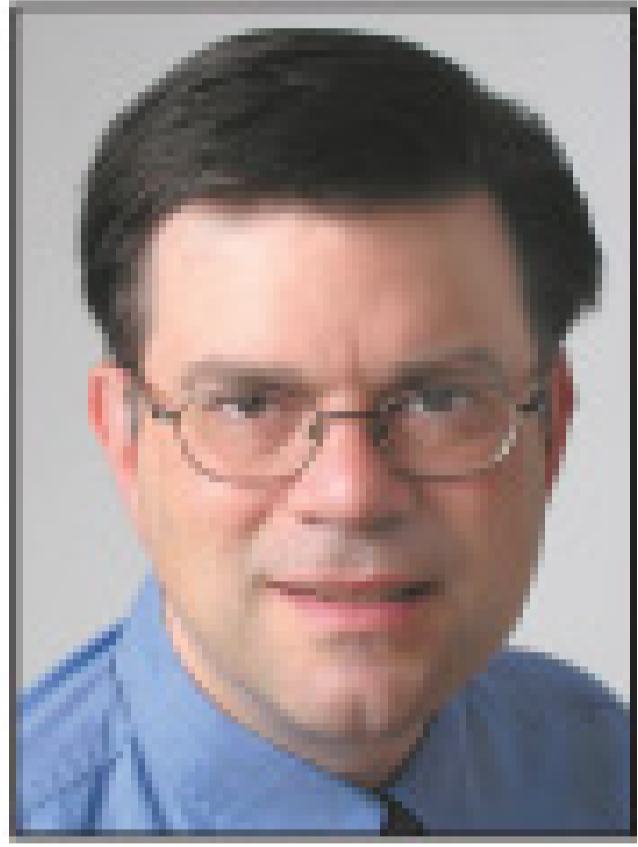

By Jim Kneiszel, Editor

Some folks overcome obstacles to make their annual trip to the Pumper & Cleaner Expo. Norton Williams is a great example of a pumping professional dedicated to attending the Expo and making the most of the educational and product research opportunities it presents, even when circumstances make it difficult.

I met Williams at the Expo in 2005. He was taking in an Education Day seminar and I recall sidling up to him to strike up a conversation.

This was Nashville in February and there was a dusting of snow on the ground and wind chills nipping below 20 degrees, not a great weather day in the mid-South. There sat Williams, alone in the corner of the big seminar room, huddled in a warm jacket and wearing a stocking cap, looking like he couldn't get warm.

Williams greeted me with a bright smile and a gentle voice with a Caribbean accent. I soon learned that he came from the tourist destination of St. Croix in the U.S. Virgin Islands, where he operates *When You Gotta Go Sewage Disposal* in the city of Kingshill. That explains the winter coat, I remarked.

Williams was attending his first Expo to shop for 10 portable restrooms to add to his modest septic pumping business on the island. Information gleaned from the Education Day seminars and the immense scope of the pumping industry energized him to go back to the tropical paradise and build up the business.

In the ensuing years, I've seen Williams in passing at the Expo. Literally in passing, both of us hurriedly moving from one booth to another in a hopeless effort to see everything offered by vendors. We acknowledged each other, but didn't always stop to exchange greetings.

---

**"IF YOU'RE SERIOUS ABOUT WHAT YOU DO, IF YOU HAVE A PASSION FOR THIS BUSINESS, YOU'LL BE HERE. AS LONG AS I HAVE THE HEALTH, THE STRENGTH AND THE FINANCES TO COME, I'LL BE HERE."**

**Norton Williams**

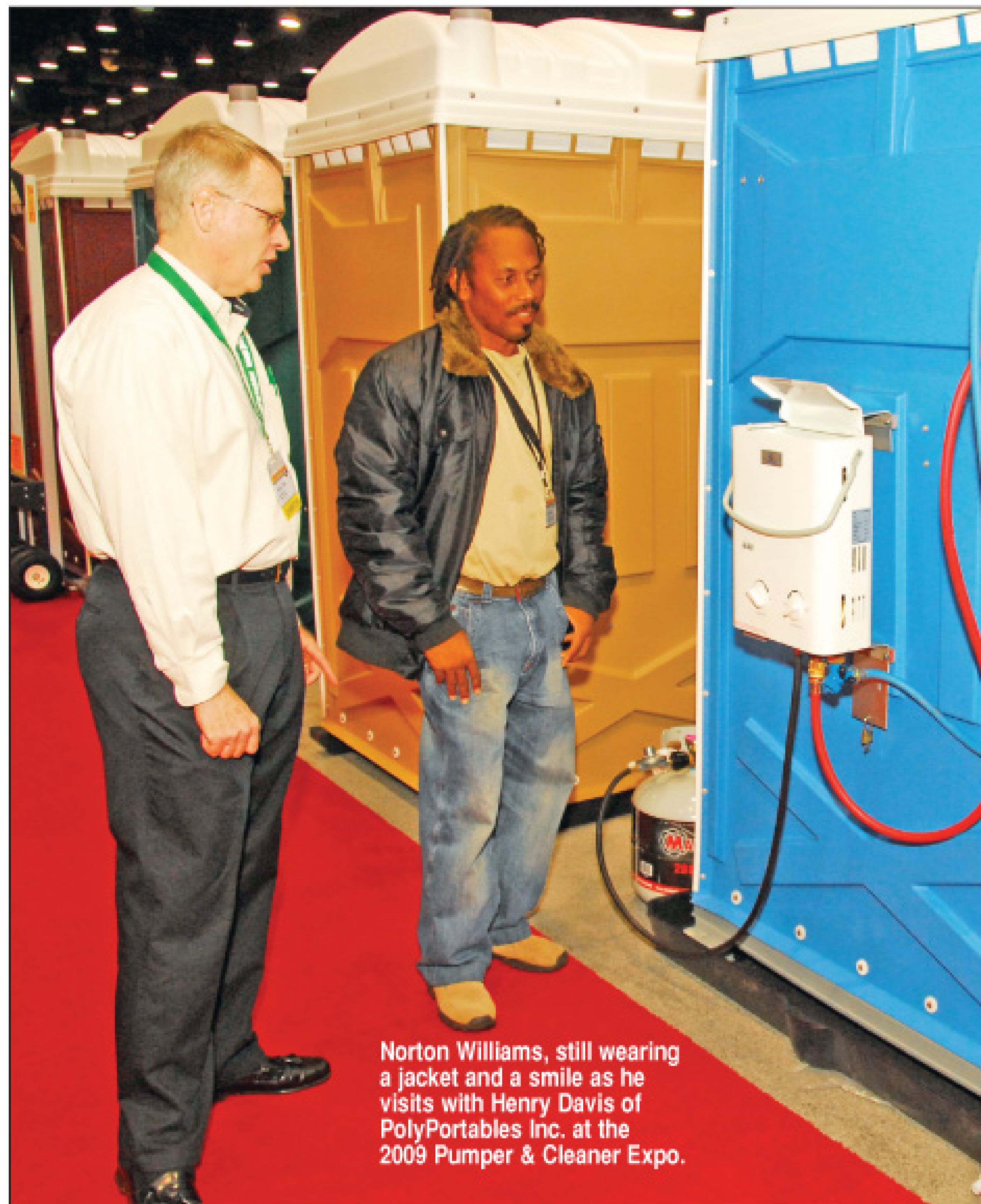

Norton Williams, still wearing a jacket and a smile as he visits with Henry Davis of PolyPortables Inc. at the 2009 Pumper & Cleaner Expo.

This year, we fortuitously landed at the PolyPortables Inc. exhibit at the same time, both looking to Henry Davis to explain the features and benefits of a new shower unit. Just like in 2005, Williams remained serious about learning anything and everything related to the industry, and made a point to express how important it was for him to attend the Expo each year.

"If you're serious about what you do, if you have a passion for this business, you'll be here. As long as I have the health, the strength and the finances to come, I'll be here," he told Davis and me.

Williams is not just blowing smoke. He explained that 2008 was a rough year, capped off by losing his wife in October. But he said their daughters are at home to support him, and he pushed himself to attend the Expo despite the terrible loss.

"She would have wanted me to continue coming here to make our business better," he said. "Life goes on and God has a better plan. I'm taking it one day at a time."

Part of what buoys Williams' spirits are the people he's met at the Expo, colleagues from across the country who are becoming lifelong friends. Just like they have supported Williams with advice over the years, he believes it's his duty to help the newcomers he meets on the show floor.

"I offer as much advice, help or knowledge as I can to people who

want to get into (the industry)," he said. "Every year I meet people buying their first portable restrooms, coming here for the first time. The first thing I ask them is, are you passionate about this? If you're not passionate about it, you're going to lose your money. You're going to waste your money."

We wouldn't question Williams' passion for the industry.

#### SEEING OLD FRIENDS

Norton Williams is one of a cast of thousands of participants who make the Pumper & Cleaner Expo a great place for me to learn and grow in the industry. It's an honor and a privilege for me to walk the exhibit floor with you and present a glimpse of the show to readers who couldn't make the trip to Louisville, Ky., this year.

If you took the time to share your thoughts with me at the Expo, I'd like to offer my thanks. I enjoyed meeting many of you at the Education Day seminar track coordinated by the National Association of Wastewater Transporters ... especially all of you nice folks from Michigan who flocked to the seminars to learn about disposal options.

In Michigan, and many other regions across the country, alternatives to septage land application and rising dumping fees at municipal treatment plants continue to be growing concerns. And so is the handling of grease trap waste, which treatment plants often shy away from taking and so many entrepreneurs are looking for profitable ways to recycle. NAWT should be commended for exploring these pressing issues throughout Education Day.

The poignant story of one pumping family's tragedy unfolded at the NAWT membership meeting at the Expo. The sad story of New Mexico pumper Rocky Horton, who died while volunteering his plumbing skills to an elderly friend, is told in a recap of the NAWT event in this issue of *Pumper*. Horton was posthumously honored with the industry's Ralph Macchio Lifetime Achievement Award.

#### MAKE PLANS FOR 30

If you didn't make it to the 2009 Expo, I'd like to make a pitch for you to think about Louisville in 2010, which will mark the 30th annual Pumper & Cleaner Expo.

At this year's show, so many people told me they weren't going to let an uncertain economy keep them from making the trip to the Kentucky Exposition Center to see new products and network with friends. A few can-do contractors told me they were refusing to participate in the recession and looking for new and innovative ways to diversify their businesses in the coming year.

These attendees counted the number of Expos they attended over the years, some missing only one or a handful. They'll be back next year. How about you? ■

**Contact us:** *Pumper* strives to serve the liquid waste industry with interesting and helpful stories. We welcome your comments, questions and column suggestions and promise a prompt reply to all reader contacts. Call 800/257-7222; fax 715/546-3786; e-mail *Pumper* editor Jim Kneiszel at [editor@pumper.com](mailto:editor@pumper.com).





**FREE** to Qualified Industry Professionals!



Subscribe online at [www.promonthly.com](http://www.promonthly.com)  
or Phone 800-257-7222

**Non-CDL  
19,500 GVW to  
66,000 GVW  
Septic / Grease Trap  
Portable Restroom  
Vacuum Service**



**Complete  
'Work Ready'  
IN STOCK  
Selection!**

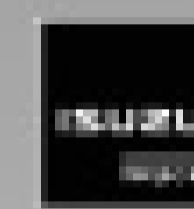
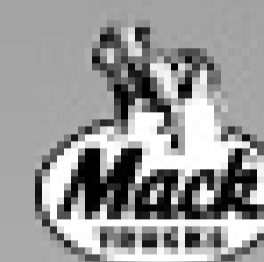
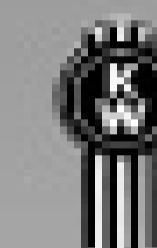
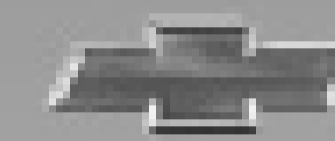
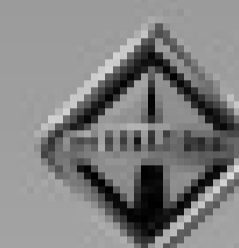

Contact: Mark C. Langworthy **800-261-9009**  
e-mail: [mlangwor@tanktruckservice.com](mailto:mlangwor@tanktruckservice.com) [www.tanktruckservice.com](http://www.tanktruckservice.com)  
**Tank Truck Service & Sales, Inc.**  
25150 Dequidre, Warren MI 48091



## Kanaflex® 220RS Rubber All-Weather Suction Hose SUPER FLEXIBLE IN COLD WEATHER

Call for Low Prices on 100' Lengths & Coupled Hose Assemblies

A revolutionary new method of manufacturing rubber suction and discharge hose has drastically reduced costs to hose users. The new process, ten years in development, utilizes Kanaflex SBR TYPE "T" POLYMER to give the lightweight, rubber hose outstanding flexibility and long life.

New Series 220 rubber suction and discharge hose has excellent dimensional stability and is easy to couple. Manufactured in six sizes from 1-1/2" through 6", the hose is available in 100' lengths. I.D. and O.D. are smooth. Temperature range is -40° F to 160° F – ideal for industry and construction job site use.

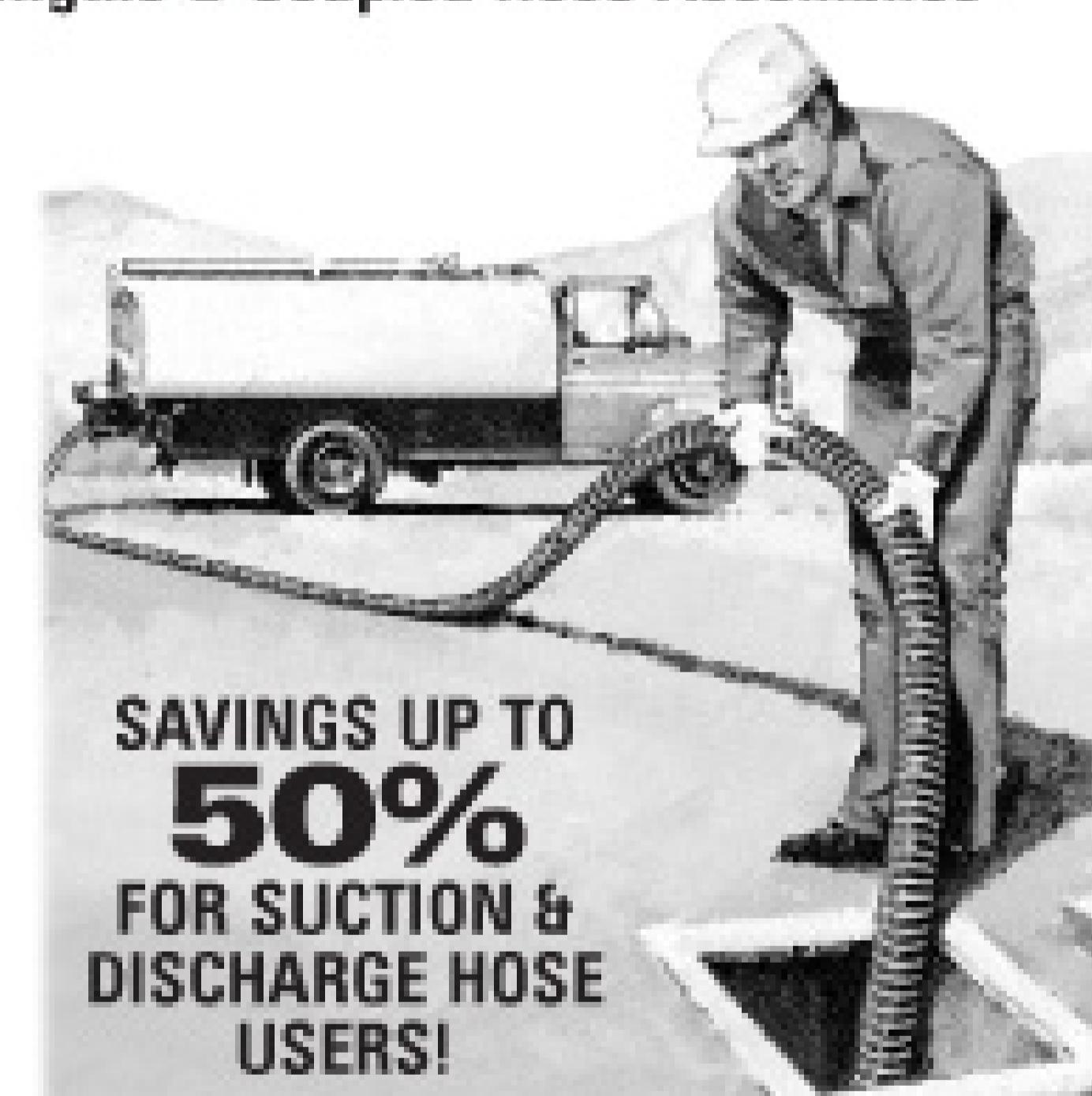

**SAVINGS UP TO  
50%  
FOR SUCTION &  
DISCHARGE HOSE  
USERS!**

Distributors of: **Dunlop • Goodyear • Kanaflex • Plastiflex  
Hi-Vac & Other Hose • P-T & Evertite Quickcouplers  
Dixon & Le-Hi Couplings • Hose Clamps • Banding Equip.**

# MRP

Milwaukee Rubber Products, Inc.

**Toll-Free  
1.800.325.3730**

[www.milwaukeeerubber.com](http://www.milwaukeeerubber.com)

FAX: 262.781.1742

MAILING ADDRESS: P.O. Box 451 • Butler, WI 53007

WAREHOUSE: N52 W13319 Falls Creek Ct. • Menomonee Falls, WI 53051



# BUY ONE, get one HALF PRICE!

Cannot be used in conjunction with any other offer.



Pallet pricing  
without buying  
a pallet!

Hurry! Offer ends May 1st, 2009



**EarthFriendlyChemicals**  
INCORPORATED

[www.EarthFriendlyChemicals.com](http://www.EarthFriendlyChemicals.com)

**1-800-753-1548**

*Comforts of Home*  
Services, Inc.



**LUXURY TRAILER SALES**

Units come with A/C, Heat, HD Steps and a Large 300 Gallon Waste Tank

- Lowest Interior Floor Height in the Industry
- ADA wheelchair accessible units.
- Unlimited Floor Plans from 8' to 53' Trailers
- Rigid Steel Shell Construction from top to bottom to resist rot and warping.
- Specializing in Customizing trailers to fit your needs.
- Easy Fold-Up Steps & Door Handles
- 24/7 Tech Support for the best customer service available.
- Free Nation Wide Lead Program for our customers.
- Large Capacity Waste Tanks
- High Privacy Partitions are Standard for Added Comfort
- Rigid Platform, our smallest wide body trailers start out with Dual 10" ASTM I-Beams.

See our website for more layouts and options.



INFO@COHSI.COM • 877.382.2935 • WWW.COHSI.COM

## Steel Tanks



Polished Aluminum Skirting and Tool Boxes

- 2009 Dodge 5500, Cummins Diesel, Automatic, 19,500 GVW, 1000 Waste, 300 Fresh

New 4x2 \$62,500

New 4x4 \$65,500

- 2008 GMC 5500, Duramax Diesel, Allison Automatic, 19,500 GVW, 1000 Waste, 300 Fresh

New \$59,000

- 2007 GMC 5500, Duramax Diesel, Allison Automatic, 19,500 GVW, 1000 Waste, 300 Fresh, Miles in 40,000

4 Trucks Available .....\$48,000 each

## Aluminum Tanks



by Amthor 5/16" Thick

- 2009 Dodge 5500, Cummins Diesel, Automatic, 19,500 GVW, 1000 Waste, 400 Fresh

New 4x2 \$71,500

New 4x4 \$74,500

- 2008 GMC 5500, Duramax Diesel, Allison Automatic, 19,500 GVW, 1000 Waste, 400 Fresh

New \$68,000

- All Brand Trucks Available

- New Septic Trucks Available

- Used Septic and Toilet Trucks Available

Portable  
Restroom  
Trailers



Trailer Mount Slide-in Tank

600 gallons waste/200 gallons fresh water.

\$13,000



8 RESTROOM | 10 RESTROOM | 12 RESTROOM | 14 RESTROOM | 16 RESTROOM | 20 RESTROOM

SLIDE-IN UNITS & USED TRUCKS AVAILABLE / MASPORT, JUROP & CONDE VACUUM PUMPS

CHECK OUR PRICES

**LANE'S VACUUM TANK, INC.**

3133 VANZORA RD. • BENTON, KY 42025

**800.592.3308 • 270.527.9945**

RODNEY LANE'S CELL 270.832.3793

We stand  
behind our  
trucks and  
trailers!



# TankTec

Tank Technologies & Supply Co. LLC  
 Portable Restroom Service Trucks  
 Septic, Grease & Grit Trucks  
 Refined Fuel Trucks

## 888.428.6422

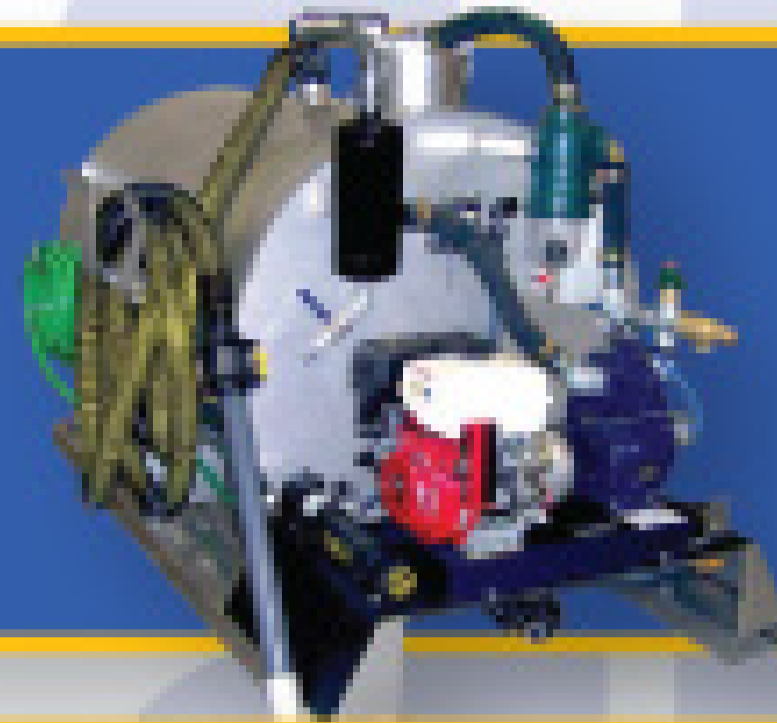

### Slide-In Tanks

300 Gallon (200/100 split)  
 450 Gallon (300/150 split)  
 550 Gallon (380/170 split)

Completely self contained and ready to work!

Aluminum Construction  
 Honda Gas Motor (5.5 hp or 9 hp)  
 Conde 70 CFM or Masport 106 CFM Pump  
 Whale Water Pump

### Portable Restroom Service Trucks **In Stock:**

1250-1700 Gallon Tank: 4 Units on hand from \$70,500: Kenworth, Ford & Sterling  
 2000 Gallon Tank: 5 Units on hand from \$71,500: Chevrolet, Kenworth, Hino & International  
 810 Gallon Tank: 10' Flatbed \$72,300: Ford

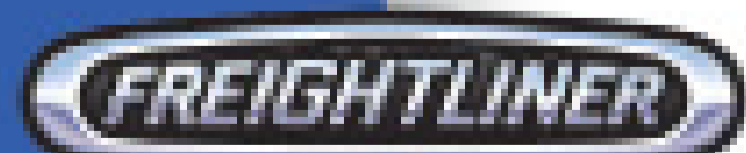
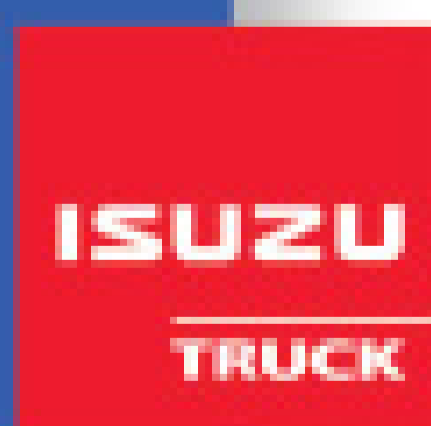

2008 Ford F550 4x4  
 1500 Gallon  
**\$75,300**

Many Trucks **In Stock**, Ready  
 for Immediate Delivery!  
 ...or custom built to your specs.



2008 International 4400  
 2200 Gallon  
**\$87,900**

### Septic or Grease Trucks **In Stock:**

2000-2500 Gallon Tank: 4 Units on hand from \$74,000: Ford, Chevrolet, International & Hino  
 3600+ Gallon Tank: 5 Units on hand from \$85,000: International, Freightliner, Peterbilt & Mack



2008 International 4400  
 3600 Gallon  
**\$106,300** +FET

Ask About In Stock Trucks • Call for Lease Payment Details  
 Tanks in Stock • Financing and Leasing Options Available • Dual-Use Options  
 Customize to Your Needs • PRS 800-2500 Gallon • Vacuum 1000-6000 Gallon

PORTAVAC



ALUMACANK

**Tank Technologies & Supply Co. LLC • 888.428.6422 • [www.tanktec.biz](http://www.tanktec.biz)**

Steve Nelson • [snelson@tanktec.biz](mailto:snelson@tanktec.biz)  
 Andy Nelson • [anelson@tanktec.biz](mailto:anelson@tanktec.biz)

Local • 763.755.8075 • Fax • 763.757.9788  
 10100 Quinn St. NW, Minneapolis, MN 55433

# Polyporables Pinups



# Miss Vantage

**APRIL 2009**

SUN	MON	TUE	WED	THU	FRI	SAT
5	6	7	1	2	3	4
12	13	14	8	9	10	11
19	20	21	15	16	17	18
26	27	28	22	23	24	25
		29	30			

**MAY 2009**

SUN	MON	TUE	WED	THU	FRI	SAT
3	4	5	6	7	1	2
10	11	12	13	14	8	9
17	18	19	20	21	15	16
24	25	26	27	28	22	23
31		29	30		29	30

**JUNE 2009**

SUN	MON	TUE	WED	THU	FRI	SAT
7	1	2	3	4	5	6
14	8	9	10	11	12	13
21	15	16	17	18	19	20
28	22	23	24	25	26	27
	29	30				

## VITAL STATISTICS

- MEASUREMENTS:** Check with my pit crew
- WEIGHT:** About your size, big boy
- FAVORITE THINGS:** Winning the pole position
- FAVORITE COLOR:** I have a dozen, but bright colors make me shine
- FAVORITE DRINK:** Fizzy blue Turbos from GWP
- HOBBIES:** Laying into turns on fast pumper rigs
- FAVORITE SAYING:** "Get it in gear Sonny, there's people waiting."
- AMBITION:** A new endurance record
- PET PEEVE:** Anything slow, ugly and smelly
- FAVORITE MEN:** Pumpers who lead the pack

**VISIT [WWW.POLYPORTABLES.COM](http://WWW.POLYPORTABLES.COM) TO DOWNLOAD A COLOR COPY OF THIS AD**

99 Crafton Drive, Dahlonega, GA 30533 USA · Phone (800) 241-7951 or (706) 864-3776 · Fax (706) 864-8111 · [www.polyportables.com](http://www.polyportables.com)

Only PolyPortables offers high-performance Green Way Products

**RESTROOM DEODORIZERS · RESTROOM CLEANERS · AIR FRESHENERS**

All Green Way deodorizers, cleaners and air fresheners are earth-friendly, people-friendly products. They are developed and manufactured in our facilities in Dahlonega, Georgia by Green Way Products, a PolyPortables sister company.





## Has the Health Department, Landlord or City complained about this?



The Outdoor Envirotub is environmentally friendly and made from 100% recycled materials. Light weight for easy movement. Stores up to 1200 pounds of grease. Non-stick plastic surface for easy cleaning and eliminates grease build up. Self closing lid to reduce odors and rain water. Built in containment, catches overflow, spills, perfect for coastal communities. Keeps trash areas clean, endorsed by property management and restaurant companies.

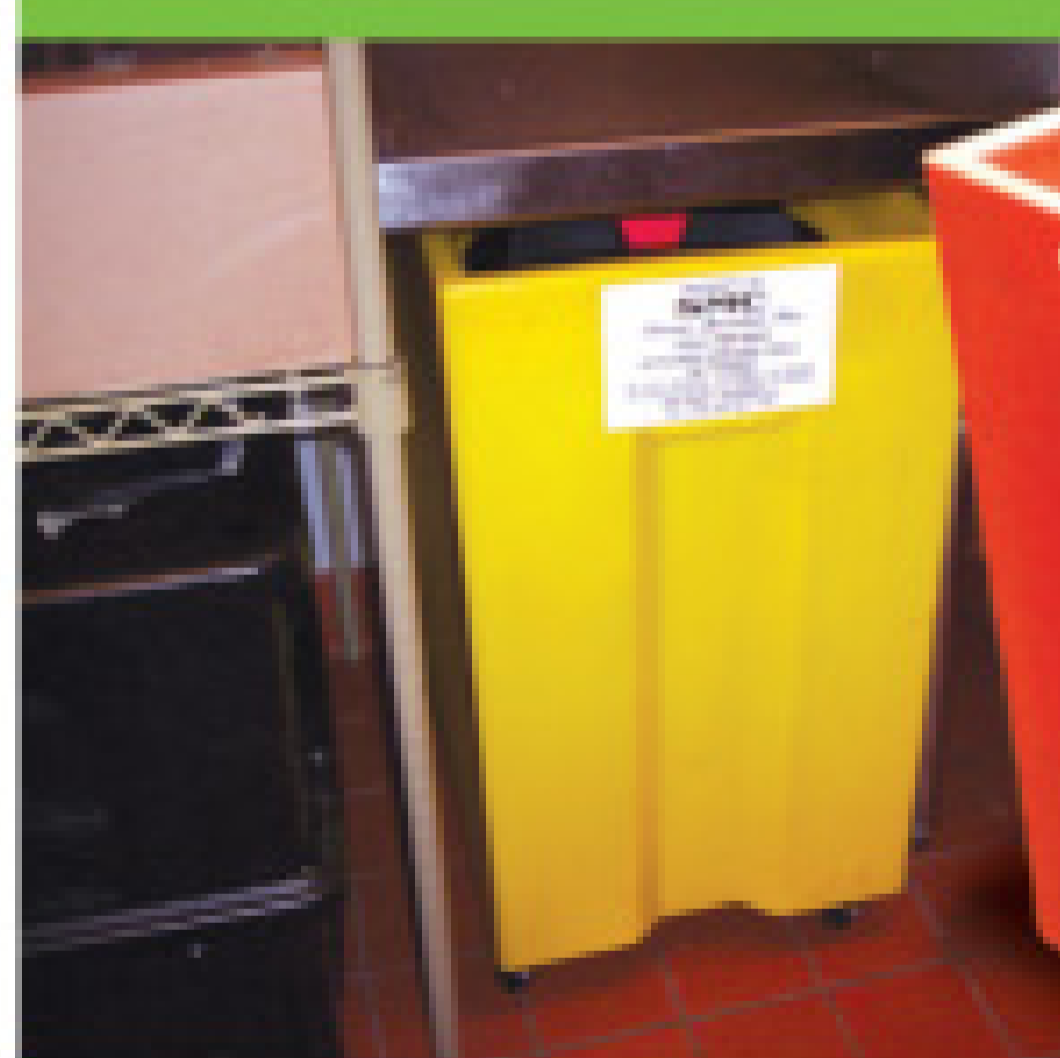

The indoor tub made to keep grease thieves away. Stores up to 55 gallons of grease. Fits under most two and three compartment sinks. Perfect for small kitchens with limited space, malls, colleges and food courts.

- > Self Closing Lid
- > Full Containment
- > 100% Recycled Plastic
- > Easily movable

# ENVIROTUB

[www.envirotub.com](http://www.envirotub.com)

PO BOX 1343, CORONA, CA 92878

1.866.777.4322

## ALLGREEN MANUFACTURING L.L.C.

American made portable sinks of the highest quality

**Portable self contained hot water sink for your job site office trailer when water is not available.**

OFFICE 401-434-1468

FAX 508-977-7889

Marc 401-477-2087

Steve 401-477-2241

ALLGREEN MANUFACTURING L.L.C. provides personal care and service with all the quality and assurance to meet today's industry standards. Twenty years in the portable restroom industry we have specialized in maintenance and design. Quality and craftsmanship is our goal in building the most affordable American made portable self contained hot & cold water sinks, emergency eye wash station sinks, portable showers and fresh water systems in the industry.



### Description:

Our portable deck sink with hot water is the most affordable compact sink anywhere. The sink is self contained and designed to run on bottled water.

### Specifications:

- > Water pump to fit any 5 gallon spring bottle.
- > 2-1/2 gallon 20 amp 110/120 volt factory pre-set @ (125° F) hot water heater.
- > Trapped drain connected to a 6 gallon grey water waste tank.
- > Soap Dispenser.
- > Cabinet Dimensions 30"x20"x36".
- > GFI Cord.

[www.allgreenmanufacturing.com](http://www.allgreenmanufacturing.com)    [sales@allgreenmanufacturing.com](mailto:sales@allgreenmanufacturing.com)

# AMT

A Subsidiary of The Gorman-Rupp Company™

## 12 VOLT DC HIGH HEAD WASHDOWN PUMP

- 1 HP Washdown Duty Motor for Severe Operating Conditions
- Investment Cast 316 Stainless Steel, Cast Iron or Cast Bronze Construction
- All Models Equipped With High Efficiency Stainless Steel Impeller
- Discharge Port Rotates in 90° Increments
- Four Front Drain Plugs
- Maximum Flow 56 GPM
- Maximum Head 80 Ft. (35 PSI)
- Maximum Temperature 200° F



The AMT 12 Volt DC Washdown Pumps are designed for pumper, septic service, OEM, and marine applications requiring a DC motor. The motor has a one hour duty rating and is furnished with a grade 303 stainless steel shaft. Washdown Duty Pumps are available in a variety of construction and seal materials to meet your specifications. Pull-from-the-rear design for easy servicing without disturbing piping.

**Call us toll free at 888-268-7867 or visit our website [www.amtpump.com](http://www.amtpump.com) for more information.**

American Machine & Tool  
A Subsidiary of The Gorman-Rupp Company  
400 Spring Street  
Royersford, PA 19468

**ots**  
OFF THE SHELF

# Advance

PUMP & EQUIPMENT INC



**Custom  
Pump  
Trucks  
Built to  
Your Specs**

**Call Today  
For  
Professional  
Blower  
Installation**



**3500 Gallon Steel Hoist Unit  
w/NVE 747 Blower System**

**NVE**  
DISTRIBUTOR



**In Stock**

**6000 Gallon Short Tanker Trailer**

- Excellent for Septic & Grease Trap Service.
- Call for more Information

**Less Trips = Less Fuel**

**Introducing the JT530  
\$4,250.00**



**Toolbox Jetter JT530**

- Polished Aluminum Toolbox
- 5 GPM @ 3000 PSI Water Pump With Pulsator
- Electric Start Engine
- Remote Fuel Tank
- Electric Rewind Reel With 200' of 3/8" Hose
- Chrome Guide Rollers On Reel
- Washdown Gun With Quick Connect Tips
- (1) Jet Nozzle
- Stainless Tool Rack

**Add Jetting  
To Your  
Pump Truck  
or Tanker Trailer**

**Introducing the JT1030  
\$5,995.00**



**Toolbox Jetter JT1030**

- Polished Aluminum Toolbox (28 x 28 x 48)
- 10 GPM @ 3000 PSI Water Pump w/Pulsator
- Gearbox Drive - Standard or optional Hydraulic Drive
- Bucket Fill/Drain
- Air Rewind Reel w/200' of 1/2" Hose
- Chrome Guide Rollers on Reel
- Wash Down Gun w/ (4) Quick Connect Tips
- Jet Nozzle - Flushing
- Includes Mounting Brackets

**Toll-Free 1.877.557.PUMP (7867)**  
"Partners in Performance"

**Call For A Quote Today!**

[www.AdvancePump.com](http://www.AdvancePump.com)

15418 Old Highway Road • Peosta, Iowa 52068  
877.557.PUMP (7867) • Fax: 563.557.0961

# Recruiting Summer Helpers

**Even in a tough economy, temporary teen workers are an effective tool to handle the seasonal rush of special event portable sanitation work**

By Ken Whiting

There was a time when it was fairly easy to find teen workers to fill summer jobs. You simply placed an ad in the local paper or asked your current employees if any of their friends' kids were looking for work. It's probably always been a little more challenging to recruit portable sanitation helpers or a youth to work odd jobs at a pumper's shop during the busy season, but a hardworking teen could always be found.

Even in a tough economy, teen workers remain an important piece of the customer service puzzle for many pumpers who offer portable sanitation. Especially now, if you've found it necessary to trim your full-time staff, summer help can be critical in smoothing over those busy days when it seems like your crew will never get all their work done before the sun goes down.

For example, you might have had an extra full-time worker or two last year when it was time to place the restrooms for the county fair or a local auto race. And those same workers picked up the slack when daily service for special events was heaped on top of the usual septic-pumping work.

Now you may need to rely on temporary workers for a few months to get the job done. And that being the case, you want to make sure you reach a large pool of candidates to find the most motivated and conscientious available teens. Getting trustworthy help is all the more important when you're running a leaner and meaner operation.

It's true that in a time of high unemployment and lagging business, teen workers don't have the many choices they once had for summer employment. But even a poor economy won't be enough to overcome the negative perceptions teens might have about working in the liquid waste industry. To attract the best summer help, you need to employ 21st century recruiting tactics. Use these ideas to cast a wider net to find the best temporary help for your busy season:

**The need for speed.** Today's teens are impatient. Keep your applications short, with just the information necessary to determine if they are interview-worthy. You can capture additional employment data if

*Ken Whiting is the author of the book WAVES for Teenage Workforce Success, which provides insights on recruiting, motivating and retaining teen workers. Contact him through his Web site at [www.WAVESforsuccess.com](http://www.WAVESforsuccess.com).*



Recruiting the best teens is just the beginning of building a strong foundation for your business. When more teens apply, only hire the "best of the best" who are a match for your business requirements. You'll improve your retention, have a more motivated employee base, and keep a young workforce inspired and engaged.

and when you meet with them. Respond to all completed applications within 24 hours to discuss the next step. If you wait ... they'll be applying somewhere else.

**Go digital.** Teens have never known a life without computers. You should have a Web site, with an easy-to-remember name. Prospective employees must be able to complete and submit their application online.

**Advertise online.** The Web is a way of life for teens today. Stay away from the local newspaper classified ads. That is the last place a teen will look. Instead, use employment Web sites like Snagajob.com, Teens4hire.org or Craigslist.org. Most communities have localized Internet employment sites. Don't forget social networking sites MySpace and FaceBook.

By the way, it's all right if you don't know much about the Web ... your younger full-time employees do. Ask them for their input and include them in the process.

**Go back to school.** You have to earn a teen's loyalty and confidence. In addition to job postings that are engaging, utilizing age-appropriate design and humor to communicate your employment message is important. Also, get involved. Volunteer your expertise in high school classrooms to build trust. Consider reaching out to the local home-school community.

**Send out the troops.** Create an internal recruitment program that provides incentives and motivates your current staff to recruit as many people as possible. It doesn't have to cost much, perhaps a token gift certificate for a local restaurant or \$20 added to their paycheck for suggesting a worker who gets hired. Give them a challenge and let them go for it. You can also utilize a signing bonus paid directly to your new hire. It's a win-win situation when you pay your current employees to be recruiters, instead of other employment advertisers.

## ONE MORE THOUGHT

Recruiting the best teens is just the beginning of building a strong foundation for your business. When more teens apply, only hire the "best of the best" who are a match for your business requirements. You'll improve your retention, have a more motivated employee base, and keep a young workforce inspired and engaged. ■

## Refrigerator Magnets

Straight Line Setup FREE!

# 1-800-758-2743

Minimum 500

Call: **STAMP WORKS**

Next Pump Date: \_\_\_\_\_

800-758-2743

Call: **Sholom** for pricing

## Quantity Discounts

Pumper Truck Shape

Actual Size 4 1/2" x 2"

## 2-color Imprint



# Michigan Vacuum Trucks

Show Specials:

## 2007 Freightliner M2

19,000.00 miles

250 h.p. Cat

NEW 2500 Gallon Vacuum Unit

Masport 400

**\$67,000**

Show Specials:

## 2003 Freightliner FL70

225 h.p. Cat

156,000 miles

NEW 2500 Gallon vacuum unit

Masport 400

**\$45,000**



All trucks are equipped with Masport Pumps  
1/4" Steel Construction

**Custom Built Tanks  
to Your Specs!**

P.O. Box 234 Carleton, MI 48117

E-mail: [mvtinc@centurytel.net](mailto:mvtinc@centurytel.net)

**Masport  
NVE**

Call for a FREE quote today!

**734.777.0390**

\*Prices are subject to change.





**814 Traditional**  
**\$17,900**

## This year's most popular model!

# Special Pricing

Rugged commercial grade restroom trailer with a large 600 gallon steel waste tank. A women's room with two private stalls. The men's room offers a private stall and three urinals! Over twice the firepower of comparably priced 1+1 units. Plus all the functionality and quality of a custom crafted Ameri-Can trailer. And a choice of colors!

- Woman's room with two private stalls
- Rugged steel frame construction
- Low flush ceramic toilets
- High efficiency ducted air conditioning system
- Brass termination valve with cam lock fitting
- Choice of interior and exterior colors

- Men's room with one private stall and three urinals
- Large 600 gallon steel waste tank
- Solid surface countertop and sink in designer cabinet
- 20 amp electrics
- Dual Dexter Tor-Flex axles
- Fold up step assemblies

**Built to last. Easy to service and set up. The best value for your money.**

America's premier restroom and shower trailer manufacturer since 1988! Ameri-Can offers over 75 models of restroom and shower trailers. Each is custom crafted, stick-built construction. Not RV style of cargo trailer refit. Built to provide many years of rugged and dependable service. Visit our website or call us for more information!

**AMERI-CAN**  
ENGINEERING  
**574-892-5151**  
www.ameri-can.com



**DENVER** Nobody  
TRUCK SALES Beats Our  
Quality!



**2005 IHC 5900**

20,000 lbs. FA. ISX Cummins, 475 HP., Jake, 18 speed transmission, RT-46160 on 46,000 lbs. air suspension, double frame, 4-way locks, New 3360 or 3750 Gallon Tanks, 420 CFM pumps, New paint, serviced and checked, NAP.

**From \$89,950 plus F.E.T. on the tank (n.a.p.)**

**Tanks  
Manufactured  
In House**



**500-4000**

Code and noncode single or 2 compartment vacuum tanks with pumps, tank options mounted on your truck or ours.

**Call for special Prices. (n.a.p.)**



**1997-2001 Western Stars 4964 SX**

16,000 lbs.-20,000 lbs. FA, 475 Cats. Jakes, 18 speed transmissions, 46,000 lbs. rears, air suspension, 3360 and 3750 Gallon Tanks, 420 CFM pump, New paint, service and checked, NAP.

**From \$59,500 plus F.E.T. on the tank (n.a.p.)**

**Complete Lines of  
Pumps and Parts**



**2002-2003 KW-T-800**

14,600 lbs.-20,000 lbs. FA, C-25 Cat 475HP, Jake, RTLO-16918 transmission, RT462160 46,000 LB rears on air suspension, new 3360 gallon tank Masport HXL-400 pump, new paint services and checked.

**From \$79,950 plus F.E.T. on the tank**

**Easy Financing and Lease-To-Own WAC!**

**Denver Truck Sales • 5293 Vasquez Blvd. • Denver, CO 80216**  
Phone: 303-291-0960 • Fax: 303-291-0244 • www.denvertruck.com

# MASPORT PUMPS

SALES • PARTS • SERVICE • STOCK

**SAVINGS ON SELECTED QUALITY MASPORT VACUUM PUMPS!**



**HXL400WV**

Liquid cooled 400 cfm, 25" Hg. continuous vacuum  
• Powerful • Quiet • Dependable

Masport

**CALL  
TODAY FOR A  
FREE QUOTE!**

WE OFFER MASPORT FIELD-PROVEN COMPONENTS TO UPDATE AND IMPROVE THE DEPENDABILITY OF YOUR VACUUM TRUCK OR TRANSPORT.



Masport



Masport

**NEW  
SYSTEMS!**

A wide range of Masport self-contained engine driven vacuum pump systems are available for the smallest to the largest vacuum truck or transport!

WE STOCK A COMPLETE RANGE OF MASPORT QUALITY PUMPS, COMPONENTS AND SYSTEMS!

**We Put Over 40 Years of Experience to Work for You!**

**CALL TOLL-FREE 1-800-528-4843**

**YOUR AUTHORIZED MASPORT DISTRIBUTOR**

**JAMES  
WILBEE  
COMPANY  
INC.**

150 Bellam Blvd.  
San Rafael, CA 94901  
415-457-6880  
Fax: 415-457-6930





# SAVE BIG!!!

## Portable Toilet Deodorizer

# VALUE PROGRAM

Designed To Save You Money... Today and Tomorrow.

## WHY PAY MORE?



Call our customer service team for more details.

**1-800-345-3303**

[www.jjchem.com](http://www.jjchem.com)



# EXPLORER

## SANITATION & RECYCLING

*The Standard In Portable Toilet Transportation!*

*Ask about Hot Dip Galvanizing!*



*Adjustable skids  
to fit a wide  
range of toilets!*



*Low pro design  
for easy loading!*

### Distribution Centers

California	Colorado	Texas	Florida	Alberta
Plumas Sanitation Tel: (530) 832-0370 Fax: (530) 832-0373 Portola CA	Columbia Sanitary Tel: (303) 526-5370 Fax: (303) 526-9586 Golden CO	Woyt Enterprises Tel: (903) 586-6493 Fax: (903) 541-0874 Jacksonville TX	Steve Baie Enterprises Tel: (407) 709-8175 Fax: (407) 822-3998 Apopka FL	Ted Hoover Tel: (403) 946-4108 Crossfield AB

Contact your local distributor  
or the manufacturer

Toll Free 1-866-457-5425  
fax 519-669-8331

email: [info@mckee technologies.com](mailto:info@mckee technologies.com)

Manufactured by: McKEE TECHNOLOGIES INC. ELMIRA, ONTARIO, CANADA N3B 2Z7



## Tanks For Your Business

Mid-State Tank manufactures stainless steel and aluminum tanks and has become a well-known and respected supplier for the agricultural, aviation, industrial and fire services, as well as pressure/vacuum tanks.

Mid-State Tank holds an ASME stamp and is D.O.T. approved.



### Mid-State Tank Co., Inc.

PO Box 317 • Sullivan, IL 61951  
(800) 722-8384 • Fax: (217) 728-8384  
[www.midstatetank.com](http://www.midstatetank.com)



*Introducing the Most Durable  
and Economical Septic Lid in  
the Market Today.*

Cost Effective  
**6 Pack  
Shipping**

Now Offering  
**Custom  
Lids!**

- Durable Roto-Molded Construction  
WILL NOT Crack Like Concrete!
- Lightweight Polymer is Easier to Handle & Transport
- Corrosion Resistant Stainless Steel Screws Included
- For use with Standard 18" and 24" I.D. Corrugated Pipe
- Easy Slide-in Installation
- Optional Sand Filled



**800.868.0973**

Don't Waste Money On Expensive Riser Systems!

*A direct reflection of people who care...*

*Did I mention our  
trucks and equipment  
are CUSTOM built  
to fit your individual needs?!*



**#1 QUALITY**

**#1 DESIGN**

**#1 SERVICE**

**#1 EQUIPMENT**



**The GapVax<sup>®</sup> cyclone design makes our unit a True Single Mode Vacuum Truck. Smaller diameter cyclones give greater centrifugal force that cleans the air more efficiently. Since relatively little material enters the baghouse, the filter bags stay cleaner longer, and they do not clog up with material which provides maximum vacuum at the work hose –this also saves on fuel. PLUS - GapVax<sup>®</sup> manufactures the only vacuum equipment on the market with NO VISIBLE DUST EMISSIONS!**

**2009 marks our 20th anniversary**



**CHECK US OUT AT [WWW.GAPVAX.COM](http://WWW.GAPVAX.COM) OR GIVE US A CALL TOLL-FREE AT 888-442-7829.**

# Connecticut Mulls Septic System Rule Changes

By **Scottie Dayton**

**T**he 2009 Connecticut Public Health Code proposes changes to septic tank and leaching system regulations. If passed, concrete septic tanks would need to include documentation of minimum strength when shipped within 14 days of manufacture. Approved manufacturers of non-concrete tanks would have to keep updated specifications and dated installation instructions on file with the state Department of Public Health.

Riser retrofits would be required only over cleanouts and outlet baffles if effluent filters were provided. Risers on tanks in paved areas would have to extend to grade. Riser and man-hole extensions to grade would have to be built to prevent

stormwater infiltration. The code would change single-family septic tank size requirements to 1,000 gallons for the first three bedrooms, and 125 gallons per additional bedroom.

Subsurface disposal system plans that include retaining walls would need to provide wall information and specifications, including the type of structure, groundwater control mechanisms (drains, weep holes), footings, and cross-sections showing existing and proposed grades. Walls within 50 feet down-gradient of drainfields would not be allowed to act as hydraulic barriers, and the inner wall edges would have to be at least 10 feet from the drainfield.

New language about manufacturer-authorized leaching sys-

tems under driveways and roads would require a one-foot minimum cover over stone trenches and H-20 load-rated precast concrete structures. Manufacturers would have to keep DPH-dated documentation on file.

Proprietary systems would need to be labeled by July 1 with identification information, such as company name and model number. When the code is released, the Connecticut Onsite Wastewater Recycling Association will post it at [www.cowra-online.org](http://www.cowra-online.org).

## MICHIGAN

In 2010, Michigan law may require haulers within 25 miles (the regulation currently states 15 miles) of a septage facility to discharge there and no longer land-apply the material.

In preparation, Kalkaska County townships are considering creating a sewage authority board and paying for a feasibility study to determine if a potential \$2 million-plus septage facility would be financially feasible. Solids would be pre-treated for use as commercial fertilizer, and liquid would go to the Kalkaska Wastewater Treatment Plant.

Six of 12 townships approved the authority board concept and agreed to pay for the \$35,000 feasibility study to determine if the area has enough septic tanks to support the venture. Waste haulers support a facility for its convenience and especially if the discharge price is lower than in Traverse City.

Some state contractors with existing septage storage facilities may land-apply until 2024.

## SOUTH CAROLINA

Two revisions affecting South Carolina setback requirements

*Rules and Regs is a monthly feature in Pumper. We welcome information about state or local regulations of potential broad interest to onsite contractors. Send ideas to [editor@pumper.com](mailto:editor@pumper.com).*

for onsite systems from wells or bodies of water went into effect on Jan. 1. One rule increases the distance between the onsite system and private well or surface water from 50 to 75 feet. The other increases the setback to 100 feet between public wells, surface water, or estuaries and systems with flows of more than 1,500 gpd. The regulations are at [www.scdhec.net/administration/regs/docs/61-56.pdf](http://www.scdhec.net/administration/regs/docs/61-56.pdf).

## OHIO

A bill in the state legislature may require rural homeowners to install onsite systems costing as much as \$50,000. Based on recommendations from the Household Sewage Treatment System Study Commission, the bill would rescind the 2007 Public Health Council's rules that provided greater leniency to rural onsite owners.

The new version states that if the cost of the onsite system exceeds the cost of a conventional septic tank and gravel drainfield and exceeds 50 percent of the home's total cost, the owner is entitled to a variance.

The legislation would require the council to adopt rules prohibiting property owners from using onsite systems when central sewers are accessible. Before granting onsite systems for housing developments with more than 25 lots, local boards of health would have to submit written documentation stating that sewers are not accessible. ■

# Pump! Save! Earn!

With **PRO-PUMP**

*The Finest Name in Biological Products for Septic Systems, System Recovery, Odor Elimination and More...*



- Septic System Treatment
- Absorption System Recovery
- Aerobic System Treatment
- Drain & Grease Traps
- Solids Reduction
- Odor Control
- Bio-remediation

**Our 33rd Year!**

**Call Greg Toll Free at 1-800-326-7867 and ask about our Special Discounts & Free Freight!**

*Solving Problems, Naturally!*

**Ecological Laboratories INC.**

TOLL FREE: 1-800-326-7867 • FAX: 516-823-3440 • EMAIL: [info@propump.com](mailto:info@propump.com)

Visit our web site at: [www.propump.com](http://www.propump.com)

# BEST ENTERPRISES, INC. SPRING BLOW OUT SALE



2009 Kenworth T300 - Hydraulic Drive - \$81,500.  
 2009 International - Hydraulic Drive - \$81,500.  
 2009 International - Angle Drive - \$80,000.  
 2009 Ford F-750 - Angle Drive - \$77,500.  
 All Single Service Units  
 All tanks are double plated on bottom



## Legendary, Reliability, and Durability

*Best Enterprises, Inc. Believes in Strength, that is why we offer the 2009 International MaxxForce DT in-line 6 Cylinder wet sleeve engine, which is easy to rebuild.*

- 230 HP
- 620 Torque (lb-ft)
- 7.6 L 466 Cu. In.
- B50 Life on Motor to 450,000 miles
- 3 Year or 150,000 mile Warranty

400/200 Slide In Unit

300/110 Slide In Unit



Now available these 2009 Trucks:

- 2009 Ford F-750
- 2009 International MaxxForce DT
- 2009 Kenworth T300

These trucks are equipped with your choice of Angle or Hydraulic driven systems.

### ANGLE DRIVE: 1100 Waste & 400 Fresh Water

- Angle Drive System with Clutch Shift PTO
- DC Burks Wash Down Pump with Hose
- Conde SDS12 Vacuum Pump on driver's side
- (2) Diamond Plated Toolboxes
- 20" Stainless Steel Manway
- Stainless Steel Toilet Carrier for 2 Toilets
- 2" x 30' Tiger Tail Vacuum Hose
- Work Lights and Running Lights

### HYDRAULIC DRIVE: 1100 Waste & 400 Fresh Water

- Hydraulic Drive system with Clutch Shift PTO
- 3K psi 4.2 gpm Pressure Washer with accessories
- Conde SDS12 Vacuum Pump on driver's side
- (2) Diamond plated toolboxes
- 20" Stainless Steel Manway
- Stainless Steel Toilet Carrier for 2 Toilets
- 2" x 30' Tiger Tail Vacuum Hose
- Work Lights and Running Lights

ASK ABOUT OUR FINANCING OPTIONS

3600 Gallon Stainless Steel Septic Truck -International  
 350 HP, Automatic, 58,000 GVW, Oversized Work Boxes, heated collars and heater coil, High pressure jetter, LC420 Jurop vacuum pump, please call Kathy Jackson for Pricing. 1-800-288-2378



## Stainless Steel Tanks Since 1978

Best Enterprises, Inc.  
 3513 W. Mt. Springs Rd.  
 Cabot, AR 72023

1-800-288-2378

[www.bestenterprises.net](http://www.bestenterprises.net)

[info@bestenterprises.net](mailto:info@bestenterprises.net)

800-334-8237  
www.keithhuber.com

We design the tools to make your job short and sweet!

**Princess**



Efficient, high performance, and durable units manufactured by Keith Huber, Inc.



Give us a call at 1-800-334-8237. If you need a portable restroom service vehicle we should talk!

**Custom Dewatering Solutions**

**COST-EFFECTIVE, TURNKEY SYSTEMS**

Built to your specifications  
Municipal • Industrial • Septage  
Mobile Units • Skid Systems • Sales • Rentals

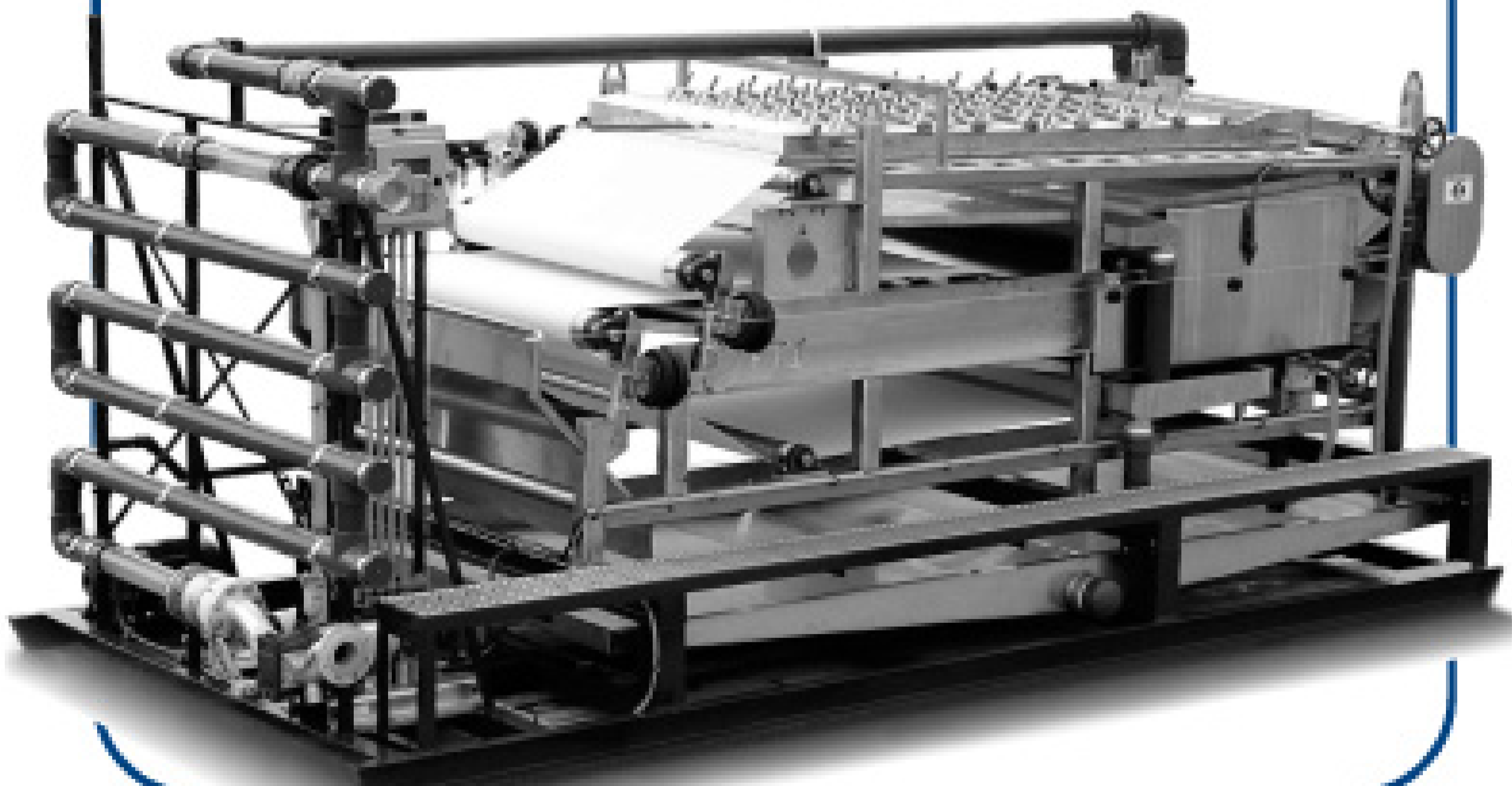

**Call 269-673-9464**

**FRONTIER TECHNOLOGY, INC.**

609 N. Eastern Ave. • Allegan, MI 49010  
E-mail: frontiertech@frontiertech.com  
www.frontiertech.com  
Fax: 269-673-9629

**Seal it Tight!  
Seal it Easy!  
Seal it Fast!**

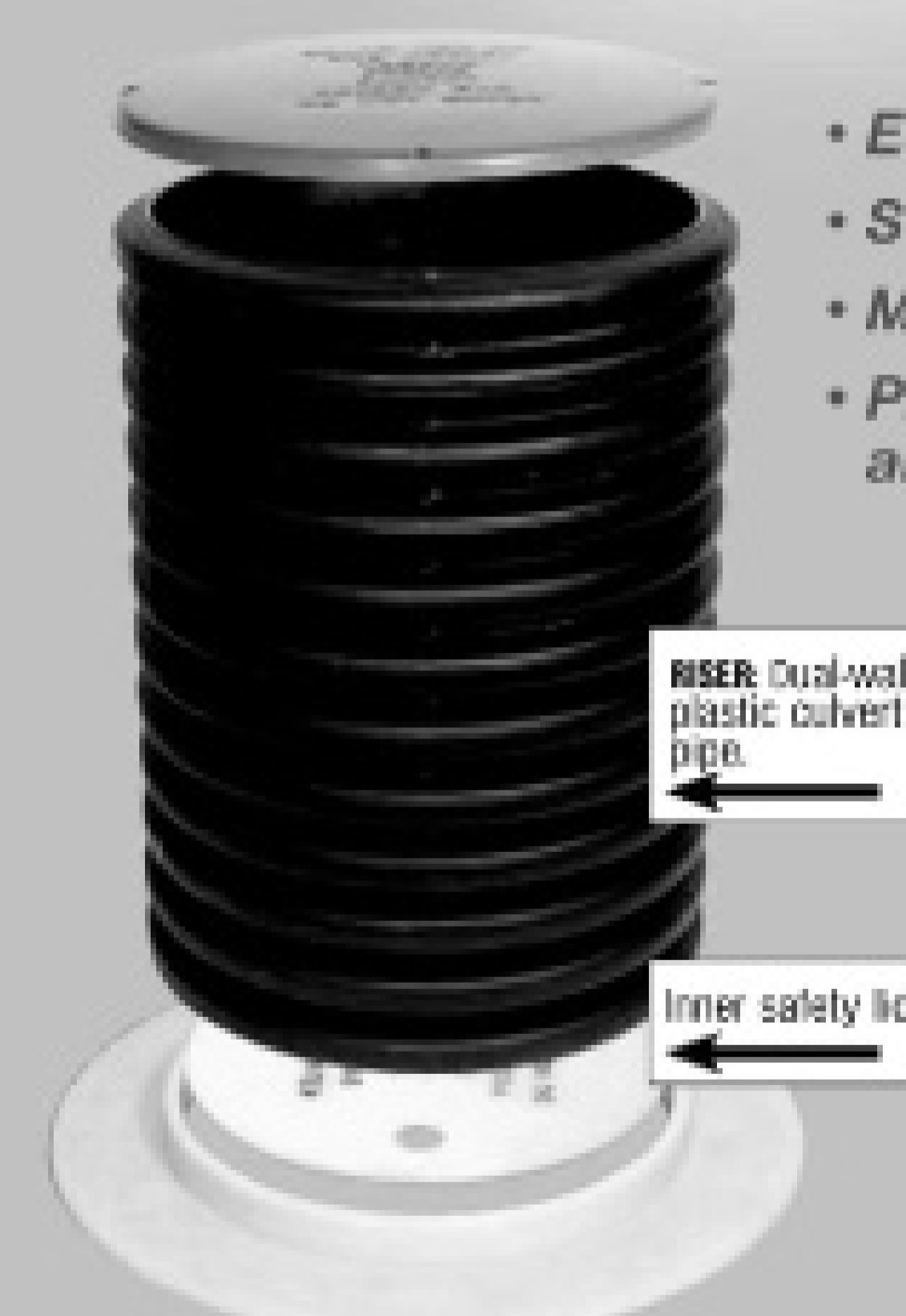

**RISER:** Dual-wall plastic culvert pipe.

**Inner safety lid.**

- Easy 10 minute installation!
- Secure fit for all systems!
- Made & sold by septic installers!
- Prevent ground water infiltration and save money at the same time!



Apply foam inside to tank.



Place ring over opening and apply foam.



Place plastic manhole pipe on ring.



Install lid.

Are you tired of using risers that are too tall or too short for the job you are completing? Plastic riser pipe will give an exact height each time. Try our system and you will never have to carry concrete pipe and lids again. Save time by not having to assemble multiple sections.

- Seal-R® Lids Available in 12", 15", 18", 24", 30", 36".
- Seal-R® Rings Available in 18", 24", 30".
- Inner Safety Lids Available in 18", 24".

Seal-R® Lids can be personalized. Seal-R® Lids are constructed with UV additive to resist degradation from exposure to sunlight.

For more information, call us today!

**BrenLin Company, Inc**  
Manufacturers of Seal-R® Products  
Herman, MN  
888-606-1998

Fax 320-677-3001 • Email: brenlin@frontier.net

www.seal-r.com

# Packaging Made Perfect!

- Industry Leading Design and Fabrication
- Dependable High Performance Vacuum Pumps and High Vacuum Blowers
- Complete, Easy to install
- Reduce your Engineering and Installation Time
- Save Time and Money - Increase Profits!

## Blower Packages



## Challenger™ Packages

## Diesel Engine Hydraulic Drive Packages with Cat Hi Pressure Pump



# NVE

National Vacuum Equipment

800-253-5500

[www.natvac.com](http://www.natvac.com)

**SAVE FREIGHT COSTS with our  
NEW Fayetteville Arkansas distribution center!**

**Designed and Built in Michigan by the  
Leaders in Engineering and Innovation!**

NVE National  
Equipment, Inc.  
801 Northfield Dr., Troy, MI 48068  
Phone: 810-253-5500 Fax: 810-253-5501

Environmental Expo Group  
By Vendor  
1 of 1 EN-EXP-2.1.06-000



# DRAGON PRODUCTS, LTD.

MADE IN THE USA!

500bbl Liquid Storage Tanks

FOLDING HAND

WITH 1/4" STEEL



Single Container Trailers  
Liquid Tight Vacuum Containers

Roll-Off Hoist

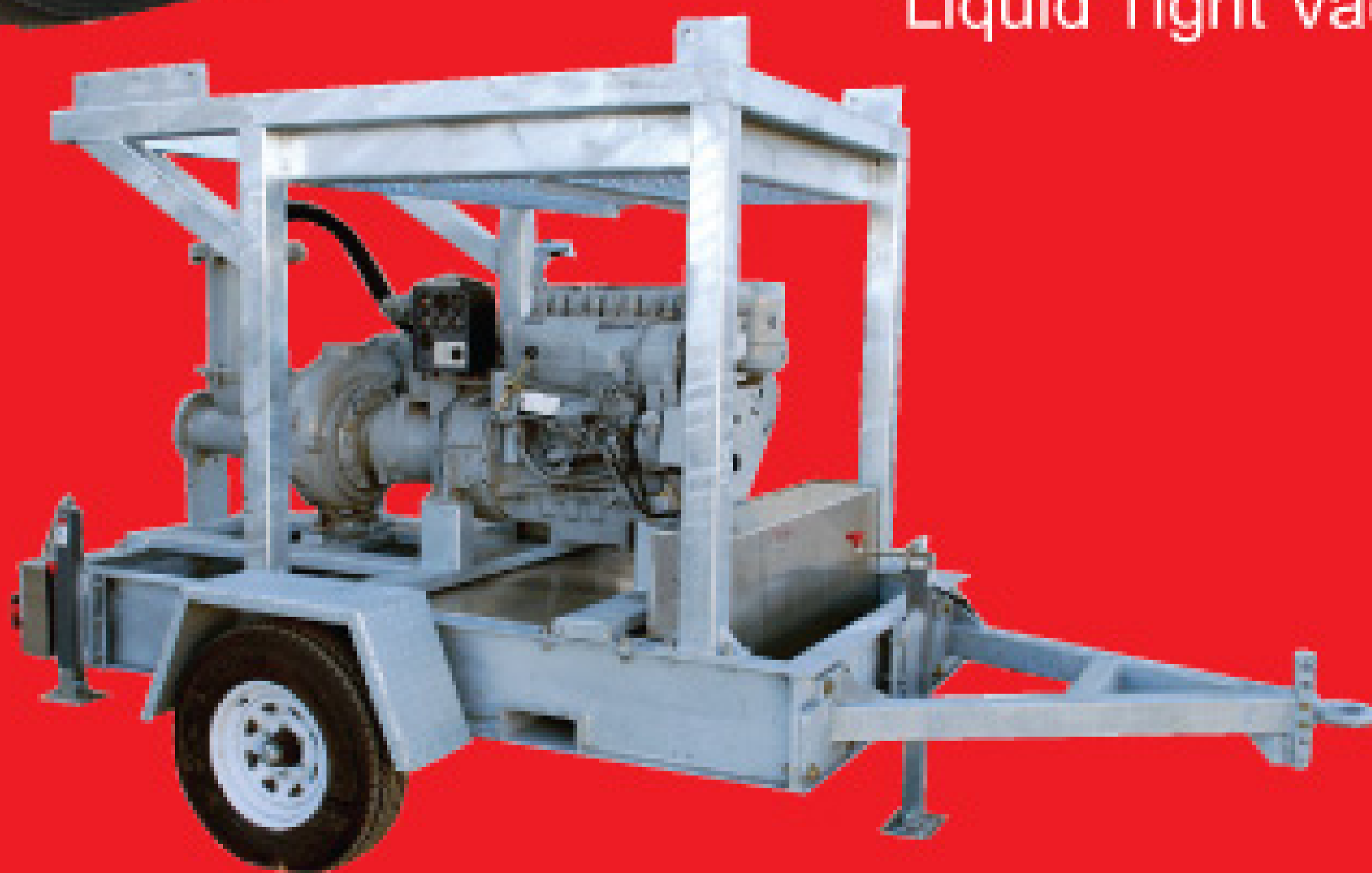

Self Priming Mobile Pump System



Two Container Trailers  
Open Top Dewatering Containers

email for more information:  
[sales@modernusa.com](mailto:sales@modernusa.com)

# 877-778-4280

A Modern Group Company

check out our website:  
[www.modernusa.com](http://www.modernusa.com)





# DRAGON

## PRODUCTS, LTD.

MADE IN THE USA!



Insulated Stainless Steel Tankers

72 WALL



Aluminum/Stainless Steel Bobtails



Aluminum Double Conicals



Full Rear End Open Steel Bobtails



Aluminum/Carbon Steel/Stainless Steel Vacuum Tankers

email for more information:  
[sales@modernusa.com](mailto:sales@modernusa.com)

# 877-778-4280

A Modern Group Company

check out our website:  
[www.modernusa.com](http://www.modernusa.com)

# POWER BOOSTER



Patented Technology for Pumping

## PL Pressure Lift Corp

- CONQUER DEEP LIFTS AND LONG HOSE RUNS
- REDUCE PUMPING TIME
- MASTER LIFT STATIONS
- INCREASE PROFIT MARGIN

CALL FOR  
**FREE DVD**

Pump Deeper – Pump Quicker

**972.355.0550**

[www.pressurelift.com](http://www.pressurelift.com)

JOIN OUR FAMILY OF CONDE  
PUMP OWNERS AND BENEFIT  
FROM

70 yrs

OF VACUUM PUMP TECHNOLOGY  
FOR THE PORTABLE, SEPTIC & GREASE PUMPING  
INDUSTRIES.

Made in America



230 cfm



180 cfm



115 cfm



70 cfm



70 cfm



35 cfm



20 cfm



Westmoor, Ltd

PO Box 99, Sherrill, NY 13461

[www.westmoorltd.com](http://www.westmoorltd.com) [pumps@westmoorltd.com](mailto:pumps@westmoorltd.com)

**800-367-0972**

# SAVE \$1,000s

## CLEARANCE SALE!

IN STOCK SELECTION!

Work Ready Aluminum Vacuum Units



**ON THE LOT! SAME DAY DELIVERY!**

**YOUR CHOICE! RESTROOM & SEPTIC!**

**Portable Restroom Trucks  
Under 2000 Gallons  
Automatic Transmission**

- 1250 Gallon / 2008 Sterling Bullet
- 1700 Gallon / 2008 Kenworth T3
- 1700 Gallon / 2008 Kenworth, 22,000 GVW
- 810 Gallon / 2008 Ford 550, 10' Flatbed

**Portable Restroom Trucks  
Under 26,000 GVW, NON-CDL, Automatic Transmission**

- 2000 Gallon / 2009 Hino 268A, hydraulic brakes
- 2000 Gallon / 2007 Chevrolet 7500, air brakes
- 2000 Gallon / 2008 Kenworth T300, air brakes
- 2000 Gallon / 2009 "Blue" trim International M7, air brakes

**Septic/Grease Collection Trucks Under 26,000 GVW, Air Brakes**

- 1200 Gallon Septic / 2008 Sterling Bullet
- 2000 Gallon Septic / 2008 Hino 338 6-Speed
- 2000 Gallon Septic / 2007 Chevrolet 7500, automatic
- 2200 Gallon Septic / 2008 International 4400, 6-speed

**Septic/Grease Collection Trucks (33,000 G.V.W.)**

- 2500 Gallon Septic on 2008 Ford 750 6-Speed, air brakes

**Septic/Grease Collection Trucks Tandem Axle**

- 3600 Gallon Septic / 2008 International 4400, 10-Speed
- 3600 Gallon Septic / 2002 Freightliner FL112, Warranty

**Septic Trucks Front Hoist/Rear Open Door**

- 4000 Gallon Steel / 2008 Peterbilt 340 10-Spd
- 3800 Gallon / 2009 International 7500

**DOT 407/412 CODE**

- 4200 Gallon 400 / 3800
- Mack CXU613



**GUARANTEED CREDIT APPROVAL!**

**NATIONWIDE DELIVERY ARRANGED!**



**Other Tank Sizes & Chassis Available For Custom Builds**



**Financing Available! New Start Up Operators...OK!  
Get KeeVac's PRICE before you BUY!**

**Call Today! 866-789-9440**

[www.keevac.com](http://www.keevac.com)



Derek and Travis Pratt of P & P Septic in Williston, Vt., pump a distribution box for a septic system that serves a mobile-home park. P & P pumps about 3.6 million gallons of septage a year. (Photos by Andy Duback)

# YANKEE INGENUITY

## Old-fashioned common sense drives practical diversification and 30 years of quality service for Vermont's P & P Septic

By Ken Wysocky

In just two words, Derek Pratt can explain how P & P Septic in Williston, Vt., grew from virtually nothing into a thriving sanitary waste disposal company: business diversification.

Since its inception in 1978 as a septic pumping business, P & P has expanded its scope of services to include portable restrooms, drain cleaning and excavating. As a result, a company that began with an old,

1,100-gallon converted fuel oil truck, an old "mud sucker" diaphragm pump and a 50-foot hand snake now owns a fleet of modern trucks and employs 18 people.

That's a far cry from the days when Derek, his brother

Darin and their father, Gary, could barely get a \$2,000 loan to buy an existing small pumping business.

The Pratts were firmly established and on their way to success in the industry when they were profiled in *Pumper* in February 1994. In

the years since that story ran, the company matured into a thriving and secure enterprise. But Derek Pratt still looks back in amazement at P & P's shoestring beginnings.

### MODEST BEGINNINGS

"At one bank, the loan officer looked at us and said, 'I don't think this business is going to work,' and shooed us out of his office," he says with a laugh. "So we went to another local bank, which loaned us \$3,000 – \$2,000 to buy

### Profile

**P & P Septic Service Inc.**  
Williston, Vt.

Owners: Gary, Derek and Darin Pratt  
Founded: 1978  
Employees: 18  
Service area: Northwestern Vermont  
Services: Septage pumping, sewer and drain service

★  
VERMONT



Jarod Pratt scrubs a portable restroom. P & P typically has from 400 to 600 units out at construction sites and monthly rentals.

**“SOME COMPANIES CAN’T DO BUSINESS IF THEIR COMPUTERS GO DOWN. IF OURS CRASH, WE CAN KEEP ON GOING AND CONDUCT BUSINESS, WHICH IS REAL IMPORTANT WHEN A CUSTOMER WITH A BACKED-UP SEPTIC TANK CALLS AND NEEDS HELP QUICKLY. IF COMPANIES CAN’T BILL A CUSTOMER OR KEEP CASH COMING IN WITHOUT A COMPUTER, THEN THERE’S A PROBLEM. SOMEONE MIGHT HEAR ME SAY THAT AND THINK I’M AN IDIOT, BUT IT’S WORKED FOR US.”**

**Derek Pratt**

the business and \$1,000 for working capital. Within a year, we bought our first vacuum truck, which was a used Chevy with a 2,000-gallon tank.”

P & P slowly developed into a full-service company that serves all of northwestern Vermont. Its business mix is approximately 50 percent septic pumping, 30 percent portable restrooms and 20 percent drain cleaning and excavating.

Pratt says the company’s diversification came naturally when they’d get out on a jobsite and see another service was required to get the job done.

“You go out to pump a septic tank, and then you find the line is clogged, so then you need an auger or a jetter,” he explains. “Then you run across a failed leachfield, so you buy a backhoe for excavating. Then you can’t find a buried tank, so you need locating equipment. Everything is just an offshoot from pumping.

“If you only pump, it’s hard to make a go of it,” he adds. “Pumping opens the door to other services, and they all go hand-in-hand. It’s difficult to do one without the other — unless you want to turn down a lot of work.”



At right: Henry Sweetser assists Travis Pratt as he (left) pumps a septic system at a mobile home park. Septic pumping represents about 50 percent of P & P’s business.



### NO MASTER PLAN

By most conventional measures, P & P shouldn’t be as successful as it is. The company never had a business plan, does little marketing outside the Yellow Pages and spot ads in local newspapers, and belongs to no professional organizations. In addition, Pratt admits he’s computer illiterate.

What the company does have going for it, however,

is a lot of good, old-fashioned New England common sense and pragmatism, combined with a strong work ethic.

“I was always told a business plan was the secret to a successful business,” Pratt says. “But we never had one, and our business has thrived. It’s all about nothing more than meeting customer demands and providing great service.”

Personal communication doesn’t hurt, either, Pratt says.

“I think it’s important to have a real person answering the phone,” he says. “When customers call a business and get voicemail or an answering machine, it kills a business. Communication with customers is key.”

That’s not to say that P & P operates completely in the technological Dark Ages.

“We’re not *that* old school,” Pratt says. “We have computers, but we don’t rely on them completely. We have hand-bill customers for pumping service calls, but our portable restroom billing and route list are computer-



P & P’s pumping fleet includes four Kenworth T800s with 4,000-gallon dump units.



At left: P & P team members (from left) include Jeff Wheelock, Ray Potvin, Henry Sweetser, John Hemingway, Travis Pratt, Derek Pratt, Thane Wood, Ben Pratt, Jarod Pratt, Steve Pratt and Jeff Pillsbury. Missing are Gary Pratt and Dan Ingham. Above: Carol Liberty and her mother, Dot Pratt, manage the office.



P & P uses four-wheel-drive John Deere tractors (above) to land-apply about 2.8 million gallons of septage from April through November. Derek Pratt and his father, Gary, (left) have seen their small business grow into a diverse sanitation company.

ized. We e-mail proposals for new septic systems to customers ... We've always invested in the most up-to-date equipment."

Pratt's main concern about over-reliance on computers revolves around equipment failure.

"Some companies can't do business if their computers go down," he points out. "If ours crash, we can keep on going and conduct business, which is real important when a customer with a backed-up septic tank calls and needs help quickly.

"If companies can't bill a customer or keep cash coming in without a computer, then there's a problem. Someone might hear me say that and think I'm an idiot, but it's worked for us."

### CRITICAL EQUIPMENT

P & P entered the portable restroom market in 1982 when the U.S. Army called to see if the company could supply two restrooms for a cold-weather research team.

"They asked us to do it and we said yes, even though I'm not sure I had even seen a portable restroom before that," Pratt says. "My dad ran down to Rhode Island and bought two restrooms. Every year since then, we've added more units."

The company typically has anywhere from 400 to 600 restrooms out at construction sites and monthly rentals, plus another 30 to 100 out on weekends for special events that range from concerts to marathons to air shows.

PolyPortables Inc., PolyJohn Enterprises

Corp. and Synergy World Inc./Satellite Industries Inc. manufacture the bulk of the company's 1,100 standard restrooms. The company also owns 25 handicapped-accessible units and two 20-foot restroom trailers made by Olympia Fiberglass Industries.

Equipment for the portable restroom business segment includes a 2000 GMC service truck built by Abernethy Welding with a 1,500-gallon, two-compartment tank and a Masport Inc. pump; a 2003 Kenworth T300 truck with a 1,500-gallon, two-compartment tank, 2006 Kenworth T300 truck with a 2,000-gallon, three-compartment tank and a 2005 Hino truck with a 1,500-gallon, two-compartment tank, all built by Transway Systems Inc.; a 1999 Mitsubishi 16-foot flatbed truck that carries 10 standard restrooms; 2004 and 2006 Isuzu 16-foot flatbed trucks that carry 10 standard units; and two Explorer Sanitation and Recycling trailers from McKee Technologies Inc. that can carry 12 standard units.

On the septic pumping end of the business, P & P relies on a 1998 Mack truck with a 4,000-gallon dump unit, and four Kenworth T800s (model years 1999, 2002, 2005 and

## You Can Charge a Premium Price for Premium Service

Charging a premium price for quality work — and not apologizing for it — helped P & P Septic in Williston, Vt., emerge as one of the state's largest sanitary waste disposal companies, says co-owner Derek Pratt.

"We get calls from people who tell us that so-and-so will do the job for half our price — but can't come for a week," Pratt says. "I tell them we can be there in an hour, and they usually say come on over, because they can't wait a week. People will pay for good service."

Pumpers who continually undercut competitors on pricing are bad for the industry overall, Pratt says, especially with the general costs of doing business always on the rise.

"Everyone should charge a premium price," he says.

In addition, companies that don't charge enough usually stay in the business for about a year or so before they fail, which also is bad for the industry, Pratt says.

"You've got to set prices high enough so you can pay your overhead, pay good benefits for your employees, pay yourself and maintain a top-notch service," Pratt says.

"We've always been on the top end, but we provide service 24 hours a day, seven days a week, and provide superior service. Customers will pay a premium because they know we'll do it fast and do it right."

2006) outfitted with 4,000-gallon dump units.

All the trucks were built by Transway Systems and feature Transway TSI 1200 pumps. The three newer Kenworths also carry jettors that deliver 6 gpm at 3,000 psi.

Drain-cleaning equipment includes two Landa Cleaning Systems jettors; a waterjetter from US Jetting; a DTW 4016 trailer jetter made by Harben Inc.; drain-cleaning equipment from RIDGID and General Pipe Cleaners; a Pearpoint lateral push camera

**"A LOT OF PUMPERS WOULD GIVE ANYTHING TO HAVE MORE CONVENIENT DISPOSAL. BUT HERE, THE ADDITIONAL CAPACITY HAS ENCOURAGED MORE PUMPERS TO GO INTO BUSINESS. IF WE HAD OUR WAY, IT WOULD BE HARDER AND MORE EXPENSIVE TO DISPOSE OF SEPTAGE ... THE LOWER TREATMENT PLANT RATES HAVE NARROWED THE GAP IN WHAT USED TO BE A HUGE COMPETITIVE ADVANTAGE FOR US."**

Derek Pratt

made by Radiodetection; and various locators made by Prototek Corp. and General Pipe.

Pratt says he's amazed at the changes in truck technology during the last 30 years.

"Basically, we can do more in an hour now than we did in a day 25 years ago," he says. "The pumps are more powerful, and the 4-inch hoses really decrease our pumping time compared to 3-inchers.

"Plus, it used to be that a big truck held 2,000 gallons, now they're 4,000 gallons, which means we can pump four tanks in half the time it used to take to pump two tanks," he continues. "Better yet, we don't need to run to the disposal site as often."

Pratt loves the trend toward jettors that now come with many trucks.

"If you don't have it, and you go to pump out a tank and find the line is clogged, it takes a lot of time to call in another truck," Pratt says. "But with the jetter on the truck, you can unclog the line and get paid for that, too ... you can jet a line at full price without calling in another service truck."

#### LAND APPLICATION IS KEY

P & P pumps about 3.6 million gallons of septage a year. From April through November, the company land-applies 2.8 million gallons on a state-certified farm. The remaining 800,000 gallons go to local waste treatment plants.

Land application offers a competitive edge because it costs about 3 cents per gallon, as opposed to 5 to 7 cents a gallon at treatment plants, Pratt says.

To apply the septage, P & P uses five four-wheel-drive John Deere tractors, two 4,500-gallon liquid-manure spreaders and various

plows and harrows.

Unlike many areas, there is more septage treatment capacity in northwestern Vermont now than there was a decade ago, thanks to federal grants that allowed existing treatment plants to expand their services. Surprisingly, Pratt feels that is detrimental to his business.

That may seem counter-intuitive. But consider that 10 years ago, it cost 9 1/2 cents a gallon to take septage to a treatment facility. Now, in an effort to attract more customers and increase revenues, the new septage treatment facilities engage in price wars that have dropped the per-gallon rate.

"A lot of pumpers would give anything to have more convenient disposal," Pratt acknowledges. "But here, the additional capacity has encouraged more pumpers to go into business," he says, noting the number of competitors has roughly doubled in recent years.

"If we had our way, it would be harder and more expensive to dispose of septage ... the lower treatment plant rates have narrowed the gap in what used to be a huge competitive advantage for us (because of cheaper land-application rates)."

#### WHERE TO NEXT?

Even with increased competition, however, Pratt says P & P sales still increase about 10 percent a year.

"Our business is like a well-oiled machine," he says. "We have a lot of

## LOOKING BACK: 20 Years of Pumper Profiles

To celebrate the advances of the liquid waste hauling industry, *Pumper* is searching the archives and revisiting service companies profiled 10, 15, even 20 years ago to see how they've adapted to changing business conditions and grown through the years. If you know of a company featured many years ago that would make for an interesting update story, please write to [editor@pumper.com](mailto:editor@pumper.com).

skilled employees who've been with us a long time and know what they're doing."

In the long run, Pratt remains grateful that a bank officer approved the loan 30 years ago that vaulted his family into the industry.

"This has been a great business for us," he says. "It's basically been recession-proof over the years. The one thing about the pumping business is that there's always a need."

And that's something Pratt and his father and brother can bank on. ■

#### MORE INFO:

**Abernethy Welding & Repair Inc.**  
800/545-0324

**General Pipe Cleaners**  
412/771-6300  
[www.drainbrain.com](http://www.drainbrain.com)

**Harben Inc.**  
770/889-9535  
[www.harben.com](http://www.harben.com)

**Masport Inc.**  
800/228-4510  
[www.masportpump.com](http://www.masportpump.com)

**McKee Technologies Inc.**  
866/457-5425

**Olympia Fiberglass Industries**  
800/544-3878

**Pearpoint/Radiodetection**  
800/688-8094  
[www.pearpoint.com](http://www.pearpoint.com)

**PolyJohn Enterprises**  
800/292-1305  
[www.polyjohn.com](http://www.polyjohn.com)

**PolyPortables Inc.**  
800/241-7951  
[www.polyportables.com](http://www.polyportables.com)

**Prototek Corp.**  
800/541-9123  
[www.prototek.net](http://www.prototek.net)

**RIDGID**  
440/323-5581  
[www.ridgid.com](http://www.ridgid.com)

**Satellite Industries Inc.**  
800/883-1123  
[www.satelliteindustries.com](http://www.satelliteindustries.com)

**Transway Systems Inc.**  
800/263-4508  
[www.transway.on.ca](http://www.transway.on.ca)

**US Jetting LLC**  
800/538-8464  
[www.usjetting.com](http://www.usjetting.com)

## Hull's Truck Bodies

459 Joe Shoemaker Rd. | Minford, OH 45653

Vacuum Trucks built to order, any size or make, delivery to all 50 states. Quick turn around time.



Phone: 877.898.5104

E-mail: [hullstruckbodies@yahoo.com](mailto:hullstruckbodies@yahoo.com)

Webpage: [hullstruckbodies.com](http://hullstruckbodies.com)

# Experience Matters.

## Custom vacuum tanks built to your specifications.

For nearly 50 years, our tank builders have been setting the industry standard for innovation and value. Everything we build is customized to your exact specifications. Start with a bare tank and add only the options that are suitable for your application. What about service? Our technicians can rebuild pumps or furnish parts such as vanes, seal kits, housings, and rotors for most pumps. Whatever you need, let us put our experience to work for you.



Bare tank w/no attachments

### Bare Tank:

Prices are for the tank only with no openings, hatches, rails or other attachments. LMT can furnish items for you to attach to your tank at additional cost. Please call for more information and pricing.



Basic tank w/optional manway and hose trays

### Basic Tank:

Prices include primary shutoff, full length rails (straight or tapered), 4" discharge nipple, and 3" intake nipple.

### Check out some of the options:

- ✓ Manways (20", 25", 36")
- ✓ Full open door (2 types)
- ✓ Primary & secondary shutoffs
- ✓ Valves for loading & unloading
- ✓ Oil catch mufflers
- ✓ Suction hose & couplings
- ✓ Mounting rails & kits
- ✓ Vacuum pumps (Jurop, Masport, Moro, Fruitland, and others)
- ✓ Hose trays and hangers

And more...

### LMT Basic & Bare Tank Prices:

(subject to change without notice)	Basic Tank	Bare Tank
1500 gallon: 54" dia. x 12' long w/1 baffle.....	\$ 5,150.....	\$ 3,765
2000 gallon: 60" dia. x 14' long w/2 baffles.....	6,200.....	4,850
2500 gallon: 66" dia. x 14' long w/2 baffles.....	7,100.....	5,700
3000 gallon: 68" dia. x 14' long w/2 baffles.....	8,000.....	6,570
3500 gallon: 72" dia. x 17' long w/2 baffles.....	9,550.....	8,030
4000 gallon: 78" dia. x 16' long w/2 baffles.....	10,685.....	9,125
4200 gallon: 78" dia. x 17' long w/2 baffles.....	11,170.....	9,580

Custom sizes up to 6000 gallon are available.

All lengths are can length excluding flanged and dished ends. All tanks over 70" dia. have 2 braces of 2" x 3" solid steel to prevent collapse of tank. All tanks are cleaned with an acid solution and prime painted. We can also customize the paint color for an extra fee. Tanks are manufactured with mild steel and are welded with submerged arc process for the best strength and appearance. Stainless steel is available at extra cost.



Call us at 800-545-0174 before you buy!

LMT Inc. - Custom Vacuum Tanks

Tel: 309.932.3311 • Fax: 309.932.3155 • info@tanksandpumps.com

www.tanksandpumps.com

**ARMSTRONG  
EQUIPMENT  
INC.**

## MODEL 806B SEELEVEL ANNIHILATOR™

### MODEL 806B SEELEVEL ANNIHILATOR™

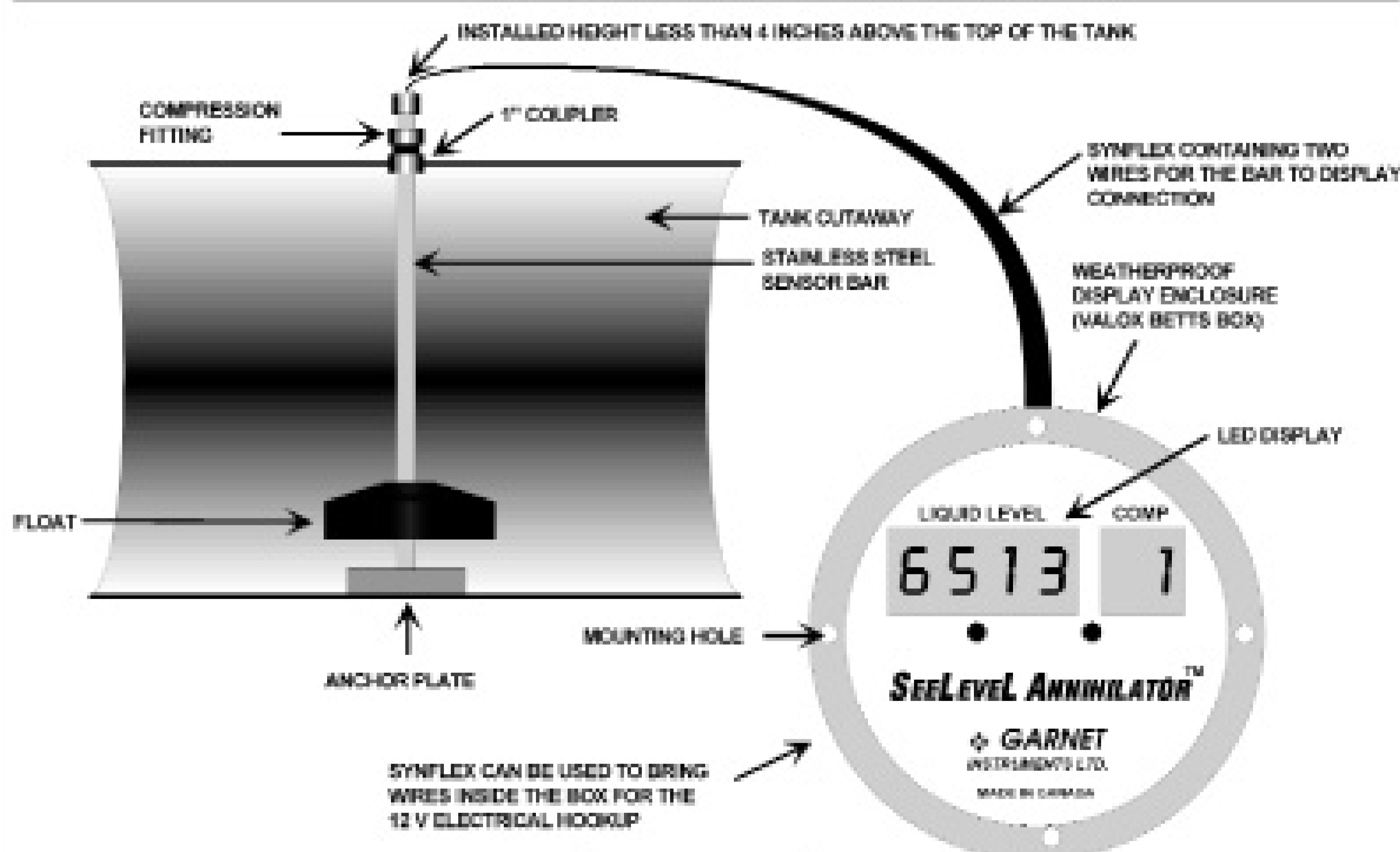

• **Accurate Readings to 1/4"**  
Even with vacuum or pressure on the tank. No need to shut down pumping to check tank level.

• **Work Safely**  
Can be programmed to control warning devices.

• **Plan Your Route**  
Tracking customers tank size allows for improved route planning.

• **Protect Your Pump, Avoid Spills**  
See the level of your tank throughout the pumping process.

• **Maximize Efficiency**  
Avoid unnecessary trips. Can I get one more load, or should I head for the dump? The guessing game is over.

• **Communicate With Your Customers**  
Pumping 1500 gallons from a 1000 gallon tank indicates problems

These are all good reasons to equip your next truck with a SeeLevel model 806B liquid level gauge system. The 806B can be programmed to read liquid levels in up to three compartments with only one display. It can also accept up to three alarm settings for triggering a warning light, sounding an audible alarm, or closing a loading valve; all while the tank is loading.



11200 Greenstone Ave. | Santa Fe Springs, CA 90670  
800.699.7557 or 562.944.0404 | fax: 562.944.3636  
e-mail: sales@vacpump.com | web: www.vacpump.com

To find out if the 806B can benefit your business, contact your tank manufacturer or call us  
**Toll Free at 1-800-699-7557**





49 YEARS OF DEPENDABILITY

# TUFF-JON

- Deep Basin, can easily wash your arm
- Rides inside portable Restroom for space saving transport
- Fully enclosed 20 gallon fresh water tank
- Foot Pump, Towel Dispenser & No Mess, No Waste Soap Container
- 2-12" wheels and built in handle for roll-a-round capabilities



INTRODUCING ...  
**TJ Junior  
Single Free  
Standing Sink**



Tuff-Jon



Tuff-Jon III



60 Gallon Rinse Tank



Tanks in 60, 105, 225, 300 and 440 Gallon Sizes

- One-Piece Construction
- Lightweight
- Rust-Free Hardware
- Wood and Poly Skids
- Large Variety of Colors

### — OPTIONAL ACCESSORIES —



7-1/2 Gallon Handwasher



Tuff-Jon with Lifting Bracket Assembly



90 Gallon Free-Standing Sink



Sky Heater



Sinks available for the Tuff-Jon III

**The TSF Company Inc.** | 2930 S St. Phillips Rd. | Evansville, IN 47712

Toll Free: **1-800-843-9286** | **812-985-2630** | Fax: **812-985-3671**

E-mail: **tsftuffjon@sbcglobal.net** | Web Site: **www.tuff-jon.com**



PORTABLE TOILETS / HOLDING TANKS / HAND WASH UNITS / ACCESSORIES

# INTRODUCING...

## After Shock

Bioremediation

Restorative

### The Next Generation in Soil Absorption Area Restoration:

#### SAME DAY BIOREMEDIATION SERVICE!

Cape Cod Biochemical Company, the premier provider of natural septic system solutions since 1976, proudly introduces the culmination of intensive, dedicated laboratory research....

#### AfterShock Soil Absorption Restorative

**AfterShock** is a unique blend of laboratory-enhanced, naturally-occurring, primarily aerobic organisms that are type-specific to the various substances that typically clog drain fields and leaching structures. **AfterShock** also contains a proprietary, bacteria-friendly, time-release oxidizing agent that will accelerate the bacterial action of the organisms in the product to restore drainage in most soil absorption areas.

Unlike **all** other oxidizing products, **AfterShock's** consortium of bacteria and oxidizer can be applied **at the same time**. The oxygen-accelerated bacterial action will quickly digest the solid material that reduces the drain field's capacity to absorb water, effectively restoring drainage through a natural process. The bacteria contained in **AfterShock** are authorized by the USDA, and have been treating septic systems around the world since 1976.

To learn more about this revolutionary approach to restoring drainage, as well as our entire line of products for residential and commercial septic system treatment, grease waste systems, and for bioremediation, please call us toll-free at 1-800-759-2257 to request our product information package. Or log on to [www.septiconline.com](http://www.septiconline.com). There is no cost or obligation, and no obnoxious salesman will call you (a big plus with us).

If you've waited to get involved with bioremediation because the process is so tedious and time-consuming, now is the time to get involved. Do it all in ONE TREATMENT. Please call today. Thank you.

—Rick Howe, President

GREEN PRODUCTS FOR SEPTIC PROFESSIONALS SINCE 1976

CAPE COD BIOCHEMICAL COMPANY

P.O. Box 990 • Pocasset, MA 02559



1-800-759-CCLS  
(1-800-759-2257)

FAX: 508-564-9974 • [www.SepticOnline.com](http://www.SepticOnline.com)



## Dewatering Solutions

GREASE TRAP WASTE  
INDUSTRIAL WASTE  
MUNICIPAL WASTE



Patented Design



800-253-0532 Toll Free USA

269-793-7183 Phone 269-793-4022 Fax

[www.brightbeltpress.com](http://www.brightbeltpress.com)

Made in  
the USA



## LOW PRICES, HIGH QUALITY

40 Trucks in Stock  
Gas & Propane  
Well Equipped

## WITROCK ENTERPRISE

Jerry Wittrock

office. 605/997-3737

mobile. 605/864-1712

Flandreau, SD

[www.wittrockenterprise.com](http://www.wittrockenterprise.com)

[jwittrock@wittrockenterprise.com](mailto:jwittrock@wittrockenterprise.com)

# Septic Tank Riser, Lid & Safety Pan™

**FREE FREIGHT ON FULL CARTONS!**

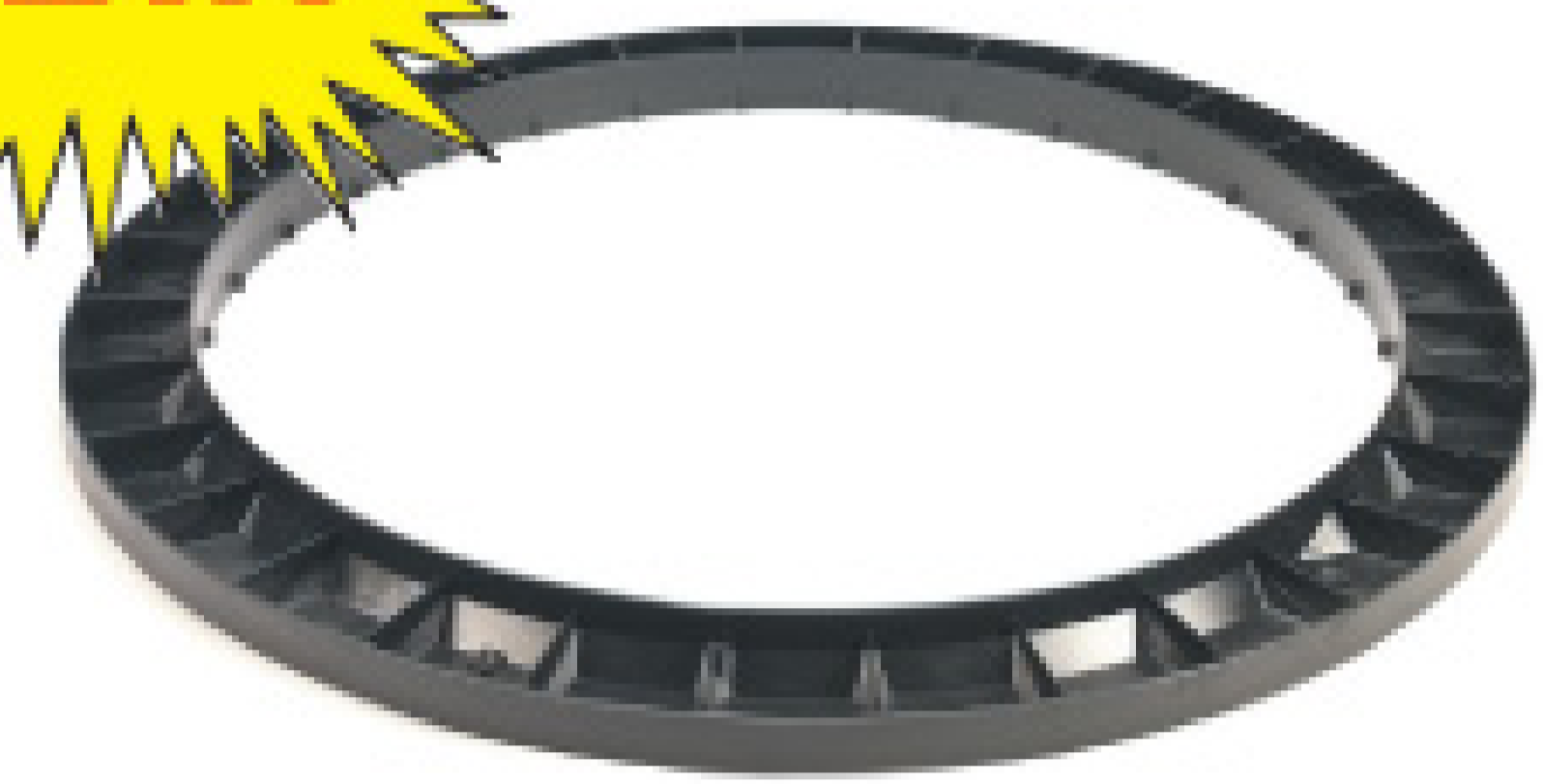
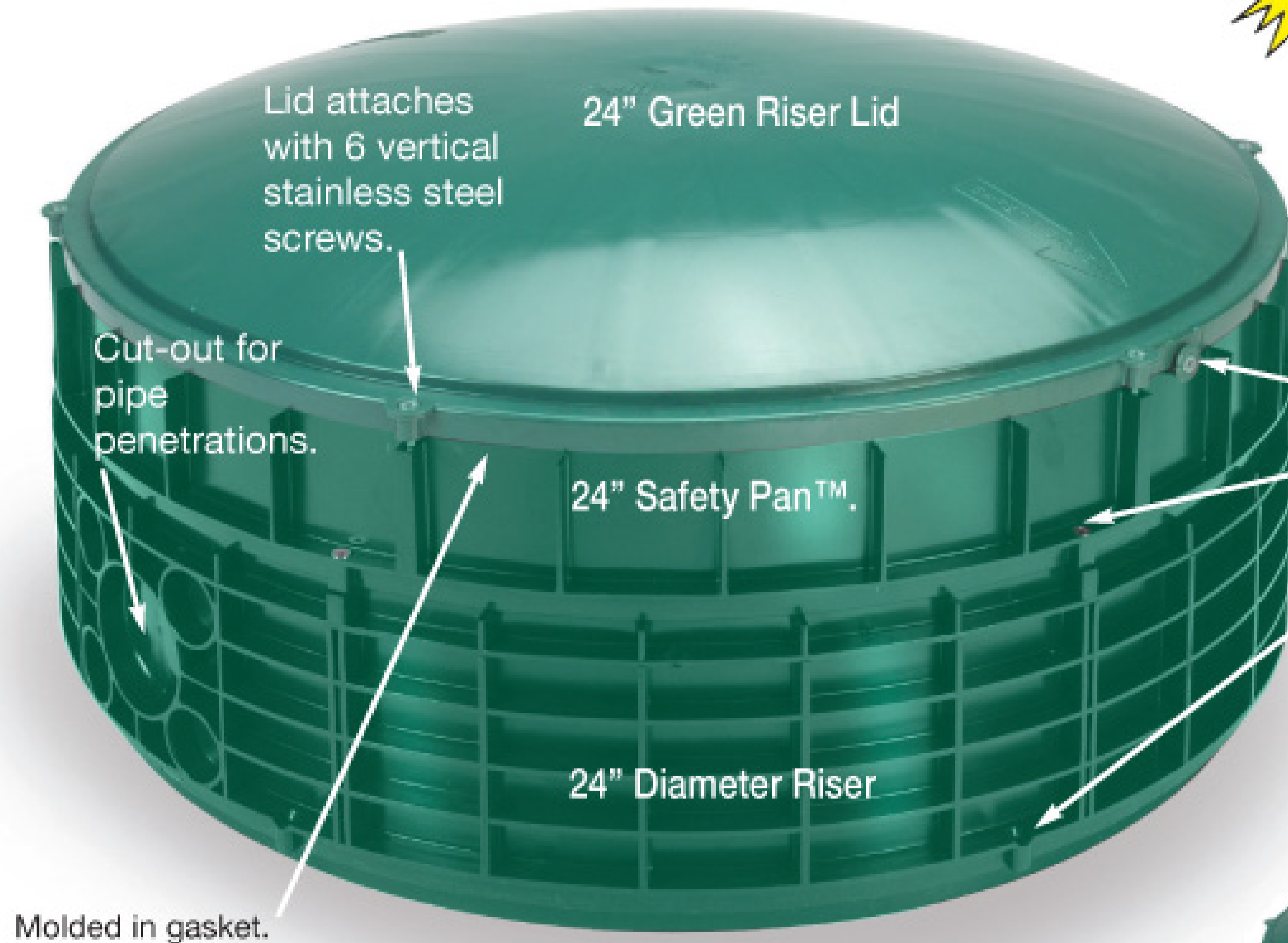

## Tank Adapter Ring

New - Horizontal Safety Screw.

Safety Pan™ to Riser attachment with 6 vertical stainless steel screws.

Riser to Riser attachment with 6 vertical stainless steel screws.

Patent Numbers  
 5,617,679 &  
 5,852,901; other  
 pats. pending.

Available in 12", 16", 20" and 24" diameters.

## Riser Lid

with Molded-in gasket.  
 Available in 12", 16", 20" and 24" diameters.

Concrete Lid w/handle

## Safety Pan™

Safety Pan™ available in 16", 20" and 24" diameters.

## Riser

For septic tanks. Stackable in 6" increments. Available in 12", 16", 20" and 24" diameters.

## Tank Adapter Ring

For mounting riser flush to top of tank when casting-in is not an option.

## Effluent Filters

Patent Numbers  
 6,319,403; D 431,629; other  
 pats. pending.

800 GPD  
 ANS/NSF  
 Standard 46

4" Sch. 40 & SDR-35

**EF-4**  
 4" Filter

1500 GPD  
 ANS/NSF  
 Standard 46

4" Sch. 40 & SDR-35

244 ft. of  
 1/16" filtration  
 area.

**EF-6**  
 6" Filter

Gas/Solids  
 Deflector

## One-Piece Tank Seal

For concrete Septic tanks and D-boxes. Accepts pipes from 1-1/2" to 4". Mounts with or without concrete flash.



**TS-4-RUBBER TANK SEAL**  
 (will hold 10psi)  
**TS-4PRO TANK SEAL**  
 (will hold 5" vacuum)

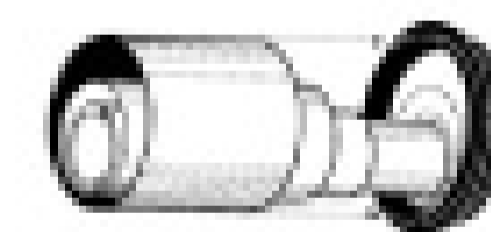

Free Freight: 32¢

Patent No's  
 4,951,914,  
 5,624,123  
 & 5,711,536;

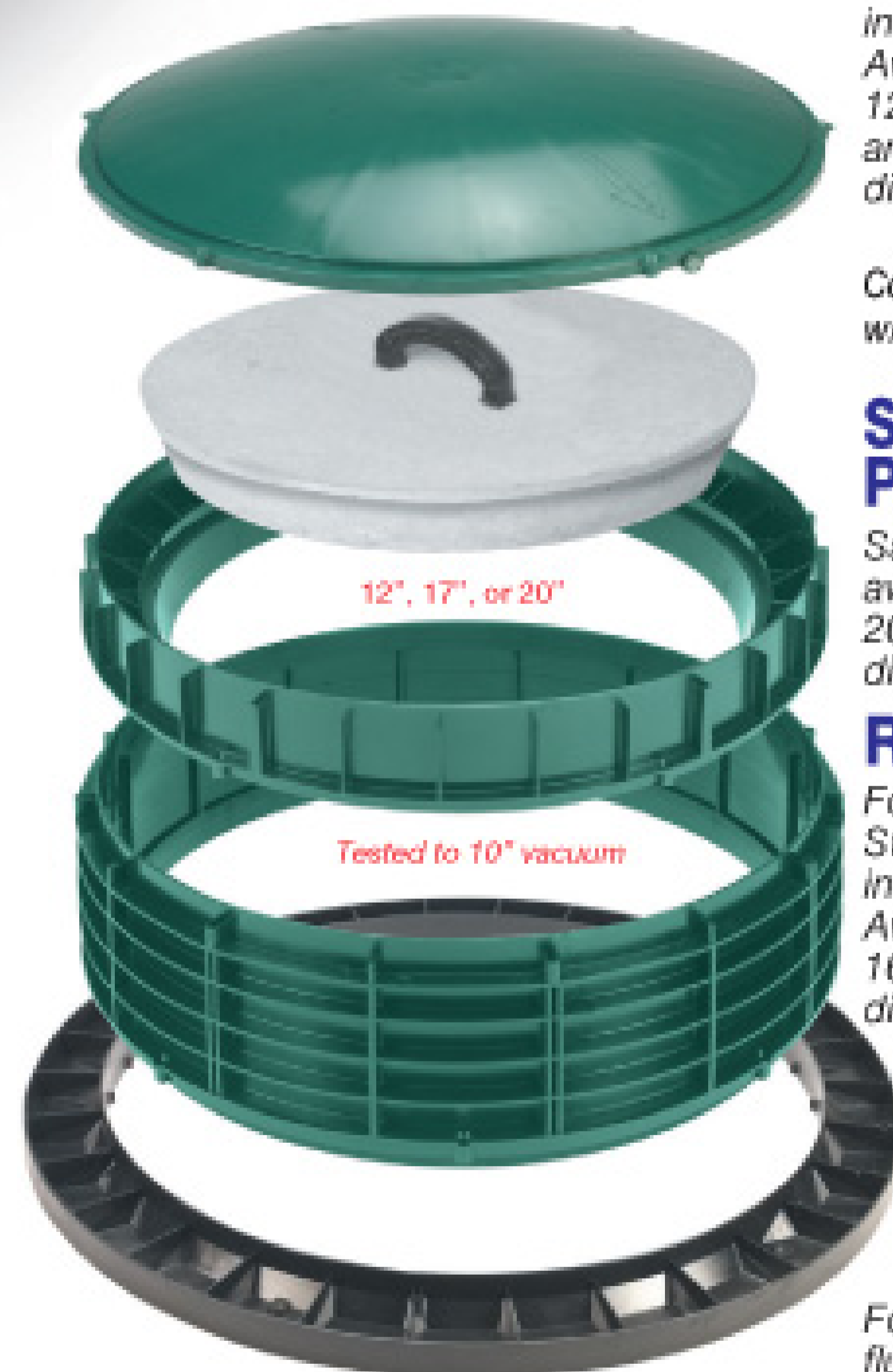

# As Seen at the EXPO



*Louisville '09*  
YOUR PLACE. YOUR TIME.

**Latest liquid waste technology  
takes center stage at the  
Pumper & Cleaner Expo**

By Jim Kneiszel and Ed Wodalski

**T**here was no shortage of innovative liquid waste technology at the 29th annual Pumper & Cleaner Environmental Expo International, Feb. 25-28, in Louisville, Ky. And despite concerns about a down economy, the event attracted 8,868 attendees and

3,780 companies. A total 519 exhibitors displayed the latest in vacuum trucks, dewatering technology and treatment systems, upscale restrooms and environmentally friendly deodorizers.

Here's a sampling of what attendees found on the show floor:

## STAINLESS STEEL TANK TRAILER

**Dragon Products and Industries** displayed its single-compartment 7,000-gallon stainless steel tank trailer. Made of 10-gauge stainless steel, the tank features a 20-inch manhole with six hold-downs. The cleanouts include 2- and 3-inch male pipe nipples within 10 inches of each head seam. A spill dam at the top manway includes a drain hose, relief valve and vapor recovery valve for over-turn protection. The level gauge is a Garnet 808P2 with 316 float. **800/231-8198; www.modernusa.com.**



## VACUUM PUMPS

**Moro Pumps** unveiled its **PM60A, PM70A** and **PM80A series vacuum pumps**, engineered to deliver 233 cfm, 300 cfm and 379 cfm at 29 psi and 1,100 rpm with a 3-inch hose connection. Features include a positive feed oil pump system, cantered rotor, Kevlar vanes, high-quality bearings and open porting manifold design. All the pumps are available for gearbox or hydraulic drive applications. **800/383-6304; www.morousaeast.com.**

## GASOLINE-POWERED PUMPS

**Conde** showcased its **SDS Ultra PowerPak** gasoline-powered vacuum pump. The unit delivers 230 cfm of free air and features double-shaft design, automatic oiling, low profile, sealed bearings, end thrust protection and tangential rotor design for longer vane life. The pump also has an electric-start Briggs & Stratton engine, V-belt drive, diamond-plate belt guard and trim. **800/367-0972; www.westmoorltd.com.**



## DEODORIZER PUMP

No mess was the word on **J & J Chemical Co.'s** maintenance-free **GoatThroat GT300** liquid deodorizer pail and hand pump. Designed for a 5-, 7-, or 15-gallon pail, 55-gallon drum or 275-gallon tote, the pump dispenses precisely measured amounts with one touch of the tap. An internal pressure relief valve prevents over-pressurizing the deodorizer container. **800/345-3303; www.jjchem.com.**



## BELT FILTER PRESS

**BDP Industries** displayed its **Model 3DP belt filter press**. The unit features a variable-speed paddle wheel for full belt-width distribution and uniform thickness. The independent gravity zone enables higher production capacity and higher cake solids. The unit's vertical arrangement allows for filtrate pans under each roll to keep filtrate from falling on adjacent rolls, while the perforated roll and stainless steel construction improves dewatering. **518/695-6851; www.bdpindustries.com.**

## PORTABLE SINK ON WHEELS

The **TJ Jr. single sink** from the **T.S.F. Company Inc.** is designed for ultimate portability and sized to fit in any T.S.F. restroom for convenient transport to the jobsite. It has 12-inch wheels to easily roll over any terrain, whether empty or full. The unit that debuted at the Pumper & Cleaner Expo is rotomolded for sturdy construction with smooth surfaces throughout. It holds 20 gallons of freshwater in a perimeter tank, while graywater is emptied into a central sump for easy cleaning. The sink comes in blue, green, tan and gray. **800/843-9286; www.tuff-jon.com.**



## RESTROOM MOVER

**Allied Forward Motion** introduced its collapsible **Mini-Metro Mover** portable restroom dolly. The mover weighs 52 pounds and measures approximately 15 inches wide, 48 inches long and 26 inches high when folded. The space-saving device features four pneumatic tires and steel construction. **920/493-2987.**



## EASY-ASSEMBLY RESTROOM PolyJohn Enterprises Corp.

unveiled a **new restroom design** that aims at greater strength and rigidity in a unit that can be assembled easily with a few tools and the fewest possible fasteners. The yet-unnamed-restroom model has some of the same convenience features as the longstanding PJ3 restroom, but has been engineered with a stronger base, corners and roof. Most of the components can be snapped together, while the unit has only two rivets, used to attach the toilet paper dispenser. The restroom replaces a

traditional one-piece skid with four feet that are anchored from all sides for greater strength. The roof is rotational molded, the door has a twin-sheet thermoformed design, and many smooth interior surfaces promote easy cleaning. The corner tank placement makes a roomier cabin and minimizes spillage in the event of a tip-over. The unit is 48 inches deep, 43 1/2 inches wide and 92 inches tall and weighs 170 pounds. **800/292-1305; www.polyjohn.com.**



## STYLIZED PORTABLE RESTROOM

**Hampel Corp.** debuted the **Sunrise portable restroom**, a curvier unit designed to make a fashion statement at special event placements. The unit uses decorative panels that bulge outward to provide a modern look and enhance roominess. The panels incorporate a large oval-shaped flat surface on all four sides for improved signage opportunities. The units come in three configurations: the Standard model with single-wall construction and traditional T-extrusions at the corners; a Twin Lock model with replaceable

interior wall panels; and the Heavy Duty model, with beefier corners for increased durability. The Sunrise door is 27 1/2 inches wide, 4 inches wider than previous restrooms, and features a three-roll toilet paper holder and a shelf with an integrated coat hook. Though it has a new appearance, the unit retains popular features from the standard Global model, including an offset holding tank and Dirt Buster base. The unit carries a lifetime warranty on door handles, springs, hinges and corner extrusions, and a 10-year warranty on other components. **800/549-1558; www.hampelcorp.com.**

## RESTROOM TRAILER AMBIENCE

**Rich Restrooms** introduced the mid-level **Everest** and the upscale **Ritz restroom trailers**, aimed at special events customers. Both models utilize an aluminum frame and durable, dent-resistant and paintable fiberglass gel coat exterior walls and water-resistant floor decking laminated on both sides. The Everest features foot flush RV-type porcelain toilets that use one pint of water per flush. The CT817 model at the Expo had three toilets on the women's side and one toilet and two urinals on the men's side. The Ritz uses an electric toilet with a wall switch for flushing. The SP816 model at the Expo had two toilets on the women's side and one toilet and one urinal on the men's side. The Everest interior is designed with durable materials for heavy use, while the Ritz features maple cabinets and an electric fireplace/heater for an upscale appearance. **260/593-2279; www.richrestrooms.com.**



## NEW BRANDING FOR ASPEN, K2 RESTROOMS

**Satellite Industries Inc.** reintroduced the stylish **Aspen** and **K2 restrooms** formerly produced by Five Peaks Technology. Satellite is rebranding the restrooms under its company name, including the patriotic red, white and blue Aspen model shown at the Expo. The units combine a bold, angular design on the outside with a host of convenience features on the interior, including cupholder, coat hook and three-roll toilet paper holder. The units also feature molded-in skid grab handles and heavy-duty twin-sheet door and jam for added durability. The K2 adds dual panel walls for easy cleaning and enhanced appearance. **800/328-3332; www.satelliteindustries.com.**



## SHAPELY PINK RESTROOM

The pink **PortaJane restroom** from **portjane.com** was displayed as a women's-only restroom with a standard flushing feature and breast cancer awareness theme. With panels manufactured by Allied Plastics Inc., the Porta Jane design incorporates an hour-glass look with cutouts in the back corners. The thermoformed front and side walls feature the recognizable breast cancer awareness ribbon design. The 40-gallon waste tank and other components are built by PolyJohn Enterprises. A sink is the only option available on the Porta Jane, with paper towel dispenser, hand sanitizer, flex ventilation pipe, hover handle, coat hooks, shelf and mirror as standard equipment. **970/729-1232; www.portajane.com.**

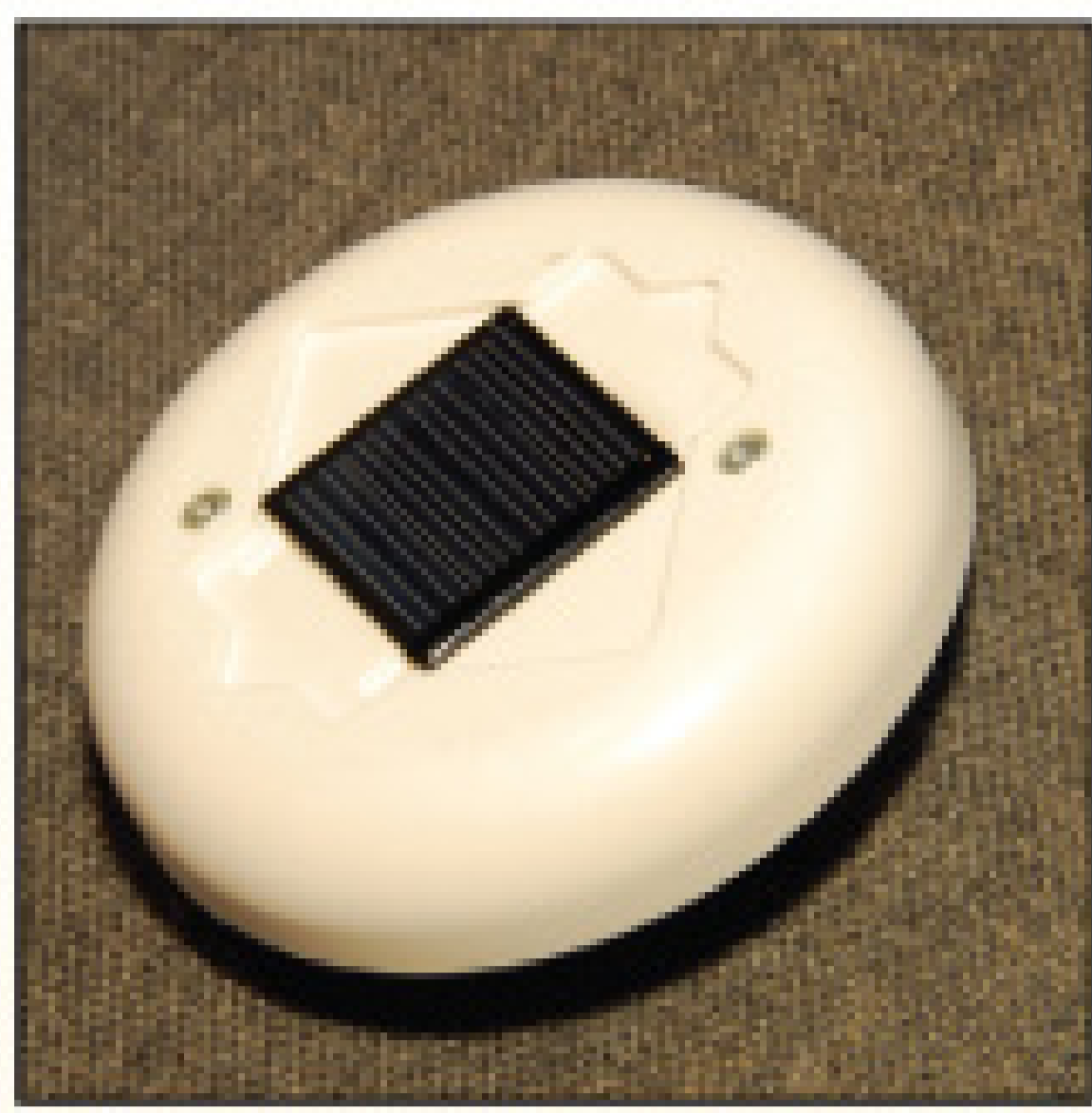

### SOLAR RESTROOM LIGHT

The **MoonLite solar-powered light** from **Dr. Shrink Inc.** offers a simple roof-mounted retrofit to bring light into portable restrooms. All that's required to install the light is a hole drilled in the restroom roof to attach the interior light unit to the exterior solar collector. The 0.5-watt LED lamp, powered by two rechargeable AA batteries, has a life expectancy of 60,000 to 100,000 hours and can run up to four nights without a

charge. The light automatically turns on at dusk and off at dawn. There is an on-off feature to turn off the lamp when the restroom is not in use. **800/968-5147; www.dr-shrink.com.**

### PRIVACY RESTROOM TRAILER

**Wells Cargo COG** introduced the **Comfort Elite X restroom trailer**, which features five individual unisex restrooms on each side of the 20-foot trailer and four exterior sinks at the rear. The trailer is designed for heavy special event use, with spray-on

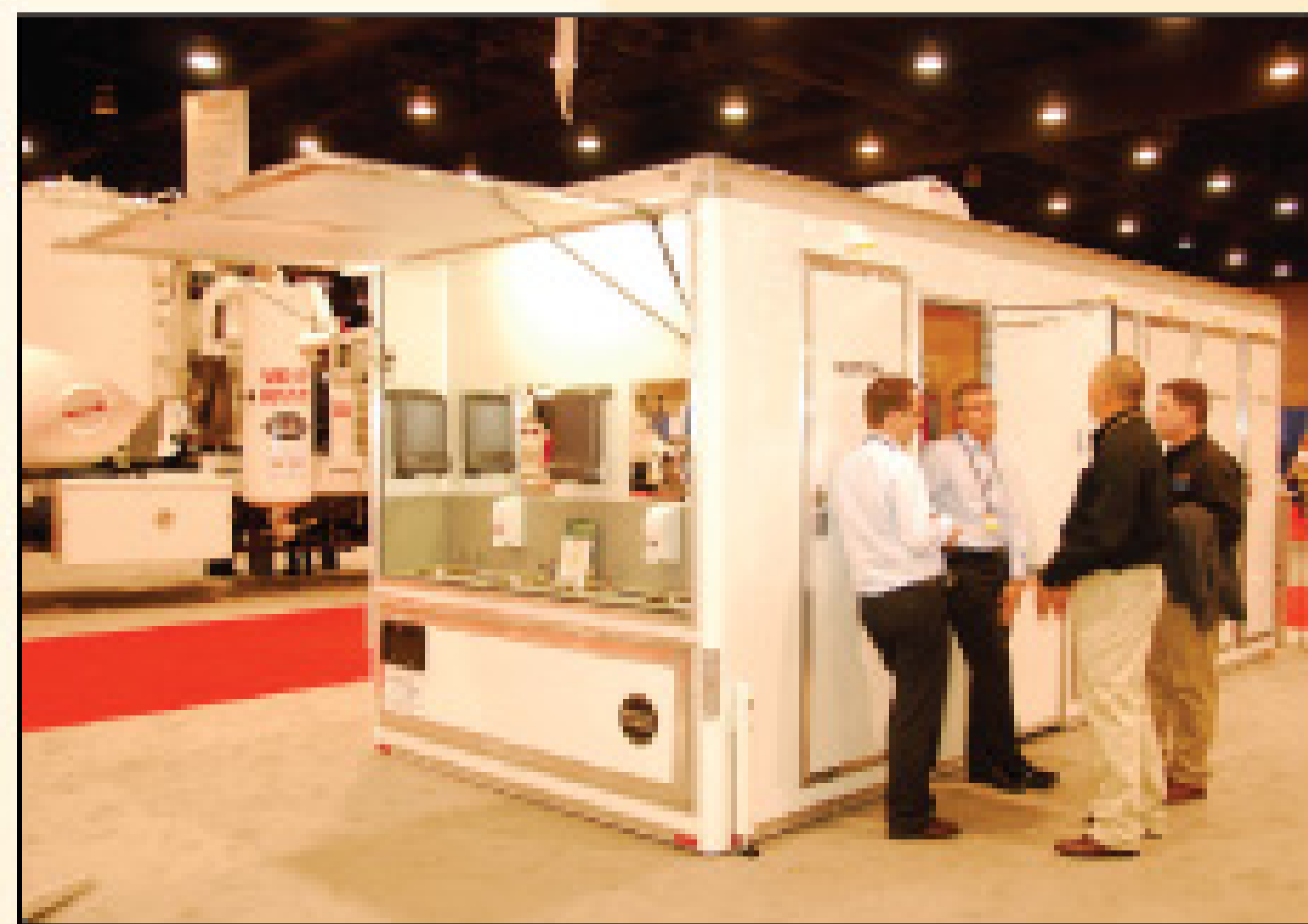

liner for the floors, heavy-duty doors and hinges, stainless steel sinks, aluminum exterior, easy wash-down cleaning and hand sanitizers in addition to the sinks. The trailer has a hydraulic lowering system with leveling jacks to eliminate the need for stairs and railings and removable drawbar/hitch for a clean look. It uses a pushbutton vacuum flush toilet and macerating pump to liquefy waste, which reduces demand for freshwater and increases efficiency. Waste is pumped to an exterior holding tank or directly into a sewer. Utilizing fluorescent lighting, the entire unit is powered by two 15-amp, 110-volt outlets. **888/574-4222; www.wellscargocog.com.**

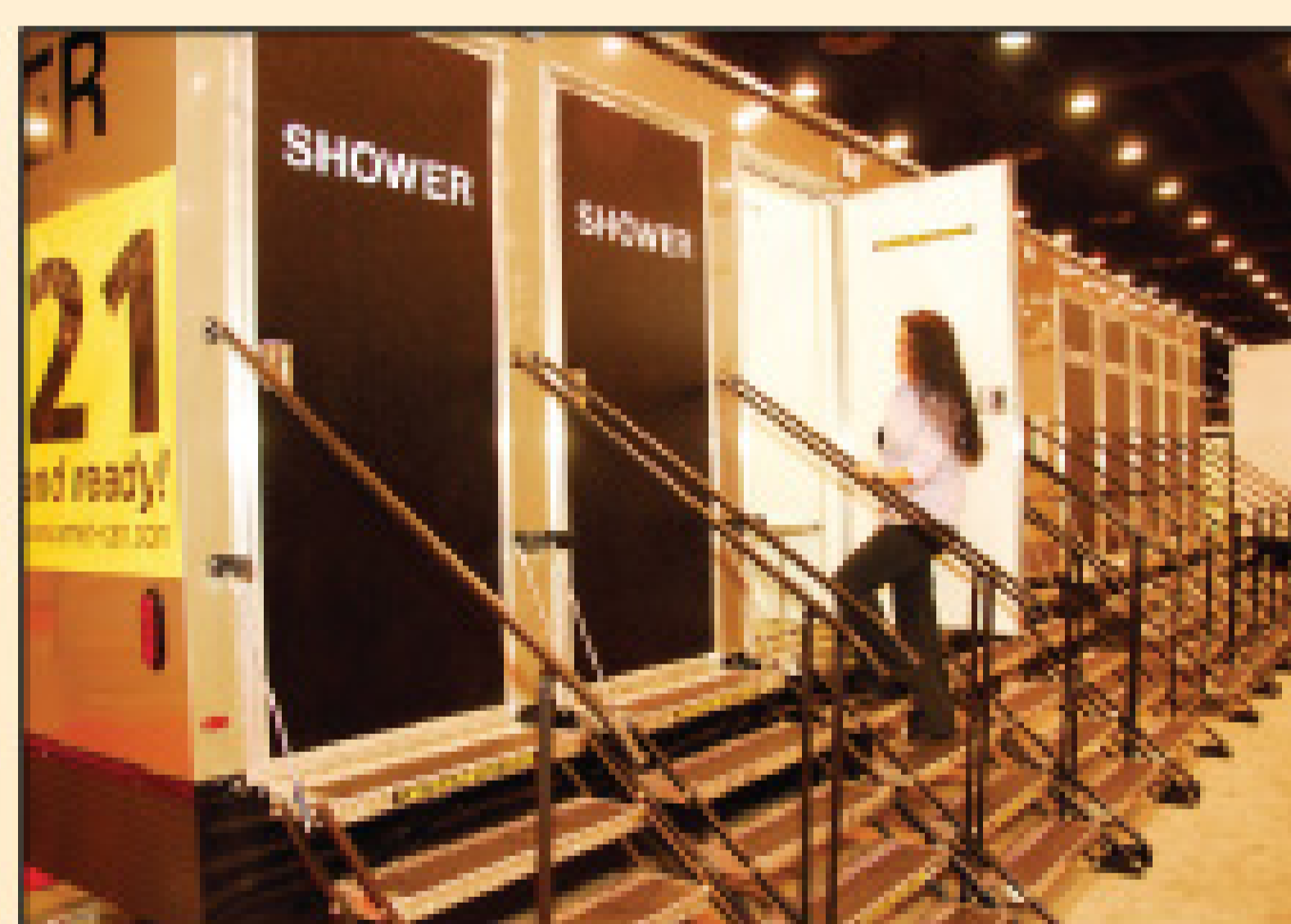

### PRIVACY SHOWER TRAILER

**Ameri-Can Engineering** introduced its **837 Shower Trailer** with 10 individual shower cabins, on-demand hot water and integrated 1,450-gallon wastewater tank. Rather than split the trailer into dedicated men's and women's rooms with

shower units, the trailer has 10 unisex stalls for enhanced privacy and better customer flow. The model can be outfitted with four to 18 showers to fit a variety of needs. Using a mitigating tank system, instant water heaters and a simple mixing valve design, the unit provides consistent 101-degree water, 20 pounds of water pressure and a 1.5 gpm flow. A pushbutton control provides a measured amount of water, preventing depleted freshwater supplies due to a valve being left open. Showerheads have a variety of massage features. Each cabin has heat, air conditioning and ventilation. With plastic-coated walls and one-piece rubberized floor, the interiors are easily washed between users. The triple-axle trailer has an aluminum exterior. **574/892-5151; www.ameri-can.com.**

### DEBRIS COLLECTOR

**Imperial Industries Inc.**

introduced its **Aluminum Debris Collector** for screening septage and portable sanitation waste at the tank discharge. Though aimed mainly at septage land application users, the tank with a 3-foot stainless steel screening comb can also be used for initial screening of waste being transferred to a storage tank. Once the unit is mounted to a truck via 2-inch receiver bars, waste runs through a 6-inch inlet and is screened through the comb with 3/8-inch teeth. Trash is trapped by the comb and the tank can be periodically cleaned through an end cap. The unit has grab handles for easy installation. The manufacturer builds a variety of spreading pans at angles to match different discharge configurations. **800/558-2945; www.imperialind.com.**



### UPSCALE CUSTOM TRAILER

**JAG Mobile Solutions**

teamed with Louisiana-based portable sanitation company Elite Portable Restrooms and Showers Inc. to produce a **luxury 18-foot special events restroom trailer** displayed at the Expo. The unit features rich accents, including African walnut and cork flooring, bamboo accent walls, custom floating cabinet and Corian countertops, flat panel televisions, vessel sinks, hands-free faucets, recessed lighting and an entertainment system with iPod. Components, including low-flow flush valves, were selected with "green" solutions in mind. The exterior features gold seamless laminated fiberglass side panels, custom paint, integrated skirts and a seamless triple-sealed roof. **800/815-2557; www.jagmobilesolutions.com.**



### PORTABLE SHOWER

**PolyPortables** displayed its individual **Fresh Start shower**. The unit features an on-demand propane-fueled hot water system, separate hot/cold water controls and 1.4 gallon-per-minute shower head flow rate. A 20-gallon propane tank provides 18 hours of use and larger tanks can be used. The containment skid collects 18 gallons of

graywater through the grated floor and a containment tray collects another 25 gallons. The shower unit includes a spray soap dispenser, coat hooks, vanity shelf and comes in 14 standard colors. It has an interior height of 83.5 inches, stands on a 41-inch square base and weighs 154 pounds with skid and heating unit. **800/241-7951; www.polyportables.com.**

## PORTABLE VACUUM SYSTEM

**Armal Inc.** introduced the **T-Easy vacuum tank**, designed for servicing portable restrooms in close quarters, including construction sites, campgrounds and special events. Available in two sizes, Model 1000 offers 336 gallons of waste capacity, 114 gallons of freshwater and weighs 1,300 pounds. Model 1300 offers 528 gallons of waste capacity, 153 gallons of freshwater and weighs 1,653 pounds. The vacuum system also features a self-retracting washing hose. **866/873-7796; www.armal.biz.**



## RESTROOM TRAILER FROM MEXICO

**Escumovil** showed the **Zapata Series restroom trailer** manufactured in Guadalajara, Mexico. The 18-foot unit on display had two toilets on the women's side and one toilet and three urinals on the men's side. The Zapata comes in sizes 8 to 53 feet. Features include laminated wood flooring, standard heat and air conditioning, Formica walls, fully enclosed stalls, Bose sound system with CD and MP3 and ceramic RV-style toilets. **619/220 01 09; www.escumovil.com.**



## ALFALFA URINAL BLOCKS

**Earth Friendly** displayed **EnviroMint urinal blocks** made from alfalfa. The 3-ounce blocks are designed to work beyond 30 days and 2,000-plus flushes. They also prevent mineral deposits and stains, while neutralizing and emulsifying oils and grease. The blocks are available in five different fragrances: cherry, NaturFresh, pine, lemon and bouquet. **800/753-1548; www.earthfriendlychemicals.com.**



## DISSOLVING TREATMENT PACKS

**Bio-Active** septic tank treatment packs and **Exodor Porta-Tab** holding tank and waste treatment tablets were introduced by **Walex Products Company Inc.** Bio-Active comes in 12-packet jars meant to be flushed into a septic system monthly to add bacteria and septic-specific enzymes to counteract the destructive effects of household products such as bleach, detergents and chemicals. Porta-Tabs have a special coating for easy handling, are designed for use in any portable restroom application and are biodegradable and non-staining. **800/338-3155; www.walex.com.**

## E-MAIL INVOICING, BILL PAYMENT

**Clear Computing Inc.** introduced its **Total Activity Control 2009.next** bulk e-mail invoicing and secure online bill payment program. The operations management software is designed to save processing time and postage costs. Other features include the ability to customize reports, view multiple panels and work with existing mapping tools, such as Google, Yahoo and Microsoft. The program also offers advanced routing and optimization, including forced start-of-day service and end-of-day service. **888/332-5327; www.clearcomputing.com.**



## FLAT RISER LID

**Tuf-Tite Inc.** presented its 24-inch, heavy-duty, multi-purpose **flat riser lid**. The product fits most commercially available risers, IPEX PVC ribbed pipe and corrugated pipe. Secured by six vertical and two horizontal safety screws, the lid features a molded-in permanent polyurethane gasket and is designed to hold 70 pounds of concrete for added safety. **800/382-7009; www.tuf-tite.com.**



## COMPACT TRIPLE-CABIN TRAILER

The 14-foot **Three Room Trailer** from **Black Tie Manufacturing** was built specifically for Wisconsin-based Arnold's Environmental Services and includes three private unisex restrooms, components for cold-weather service and upgraded entry steps with a deck. Each chamber has its own sink and decorative wood trim. The trailer has an integrated 225-gallon freshwater tank and 450-gallon wastewater capacity. Insulation and heating pads keep the tanks from freezing. **877/253-3533; www.blacktiemanufacturing.com.**

## DRAINFIELD MEDIA

**Infiltrator Systems Inc.** debuted its **Smack-Rock** engineered media that replaces gravel with expanded polystyrene. The media, manufactured from recycled materials, surrounds a perforated pipe, eliminating fines and reducing compaction and embedment. It comes in 10-foot sections and is held in place by high-strength netting. The internal pipe and couplings meet ASTM F405 requirements. **800/221-4436; www.infiltratorsystems.com.**





## PUMP PACKAGE

**Orengo Systems Inc.** introduced the **Biotube EasyPak** pump package. The unit is designed to filter and pump effluent from a pump tank to gravity or pressurized dispersal. Complete packages for on-demand dosing or timed dosing at 10, 30 and 50 gpm are available. The system includes three Biotube effluent filter cartridges, splice box, pump vault, 4-inch turbine effluent pump, float switch assembly, discharge plumbing assembly and control panel. **800/348-9843; [www.orengo.com](http://www.orengo.com).**

## FIBERGLASS TANKS

**Webtrol** featured its **fiberglass septic and advanced treatment tanks**. Offering a double-rib design, the tanks are made of high-quality resin fibers and bonded together well above the inlet for a leak-proof unit. Containing no middle seam, the tanks include a built-in lifting system for easy setting. **800/769-7867; [www.webtrol.com](http://www.webtrol.com).**

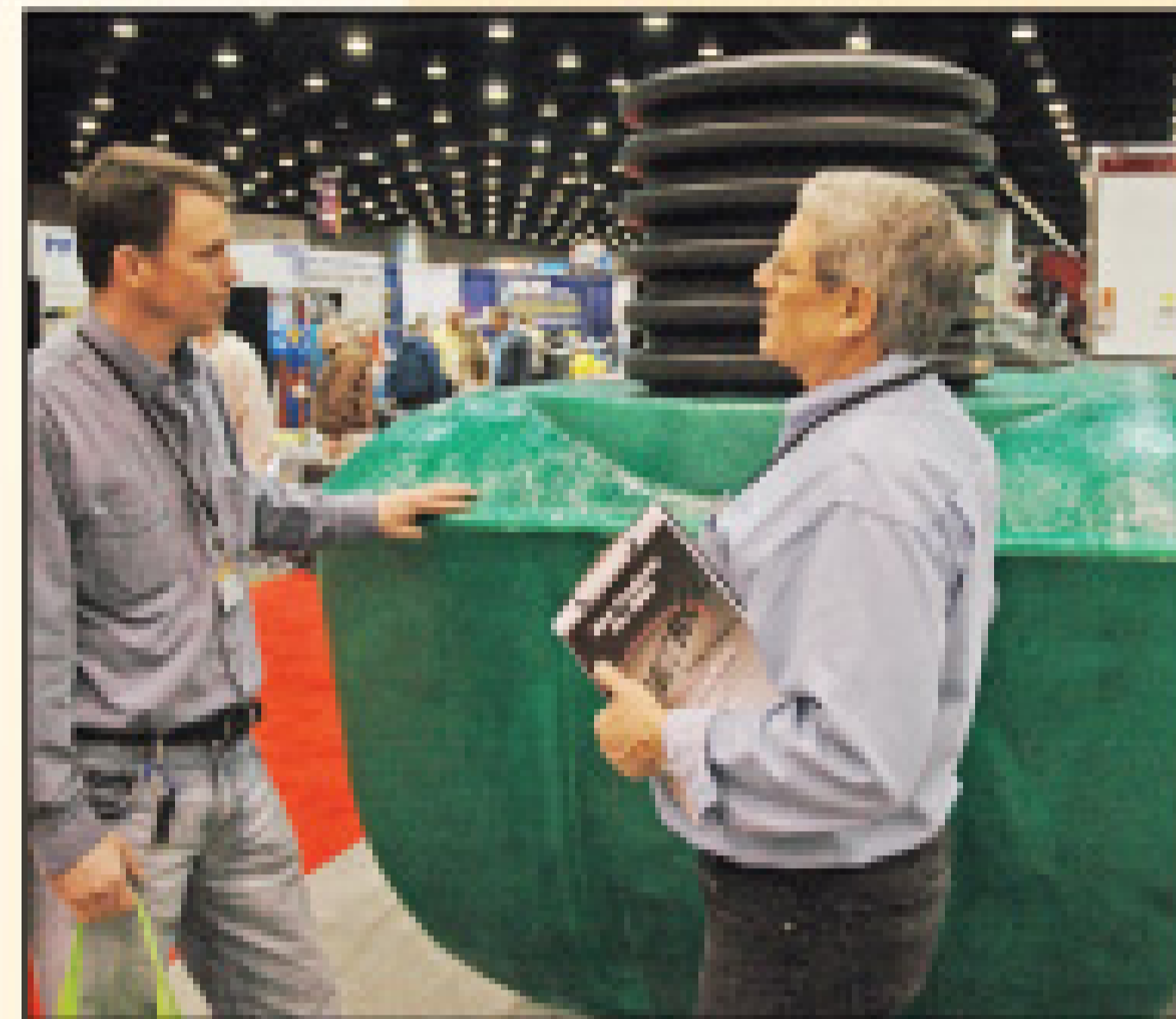

## SUPERSIZED CONSTRUCTION SERVICE

**DropBox Inc.** displayed the **40-foot Sanitation Station** running water restroom for busy industrial or construction site settings. The modified storage container offers a men's side with three toilet stalls and a

women's side with a single toilet. The unit has a 2,100-gallon tank for freshwater and wastewater and operates with a 220-volt single-phase hookup. The unit is insulated, has air conditioning and heating for comfortable use in any weather and is built with a rugged Rhino Liner interior floor for durability and easy cleaning. The heavy-duty unit is meant to augment traditional portable restrooms, typically placed at busier central break areas at large worksites. **888/388-7738; [www.dropboxinc.com](http://www.dropboxinc.com).**

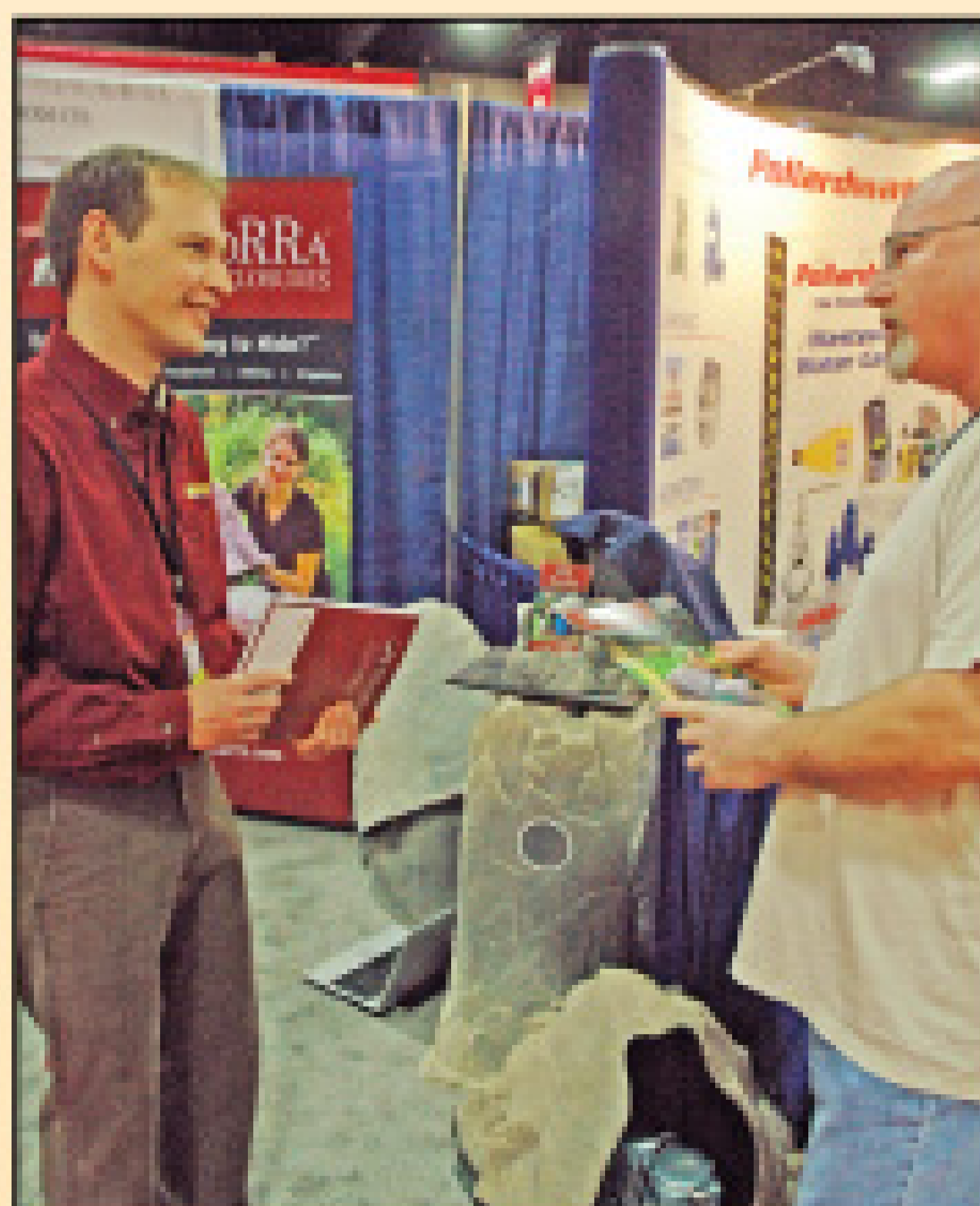

## ROCK ENCLOSURES

**Dekorrra Products** displayed its **Model 113 pedestal rock enclosure**, designed to conceal septic vent pipes as well as telephone and cable pedestals up to 33 inches tall. The enclosures measure 18 inches long, 17 inches wide and 34 inches high. Weighing 8 pounds, the pedestals are available in either brown riverbed or soft grey fieldstone. **888/635-8585; [www.dekorrraproducts.com](http://www.dekorrraproducts.com).**

## AEROBIC TREATMENT SYSTEM

**Aero-Tech** introduced its **aerobic treatment system** that's designed to convert wastewater into a clear, odorless liquid. Wastewater enters the 4-inch inlet pipe and is infused with air from the submersible aerator pump at the bottom of the aerobic treatment plant. The venturi created by the pump pulls fresh air from the surface and mixes it with effluent in the bottom of the tank. In the clarifying chamber, the liquid is suspended in the quiet zone, allowing the remaining suspended solids to settle back into the mixing chamber for further treatment. The clear water is then discharged into the disposal system. **574/935-0908.**



## CLEAR ENCLOSURE BOXES

**Fibox** displayed its **clear cover ARCA non-metallic enclosure boxes**. Available as a screw cover, hinged screw cover or a hinged enclosure with latches, the boxes are available in either opaque or transparent cover for easy control reading. The insulated boxes have a long-term temperature range of -40 degrees F to 175 degrees F. Mounting plates, fixed inner panels and hinged inner panels are available in metal or non-metallic versions. **888/342-6987; [www.fiboxusa.com](http://www.fiboxusa.com).**



## BIOFUEL MICRO-REFINERY

**BioFuelBox Inc.** displayed its **BioFuelBox** for waste-to-fuel applications. The micro-refinery is designed to convert waste fats, oils and greases that are high in free fatty acids, water and contaminants into low sulfur, on-road ASTM 6751-08 compliant biodiesel. Waste feedstock options include trap grease, waste vegetable oil, wastewater scum, DAF skimmings, brown grease and high FFA yellow grease. **888/383-5269; [www.biofuelbox.com](http://www.biofuelbox.com)**

## SEWAGE TREATMENT

**PekaSys** displayed its two-section **Clear Rex Bubbler** biological sewage treatment plant, designed to transform almost any septic tank into a wastewater treatment system. The pre-assembled, pre-programmed unit is engineered for two to 2,000 users. The fully automatic system operates off a 120-volt power supply and requires a 3-foot minimum tank depth. Developed in Germany, its treated wastewater consistently meets the U.S. EPA secondary treatment standards of 30 mg/L BOD and 30 mg/L TSS. Data can be transmitted via cell phone, while disruptions can be cleared by sending a message to the system. Pump data also can be called up and viewed at any time. **267/242-2303; [www.pekasys.com](http://www.pekasys.com).**





## SAFETY LIGHTING

**A & L Systems** put the spotlight on its **9016LED series StarBeam** and **M-Tech LED mini-bar safety lighting**.

Both feature 360-degree light output in amber, clear or red dome colors. Made of durable polycarbonate, the injection-molded domes are fully gasketed to protect against moisture, while potted circuitry protects against shock and vibration. Also on display was the N200 HID (high intensity gas discharge) work light.

Designed to produce near-daylight illumination, the xenon light is resistant to shock, vibration, water and dust. **800/592-5253; www.a-and-lsystems.com.**



## DRAINAGE UNITS

**ICC Technologies LLC** introduced its **Flowtech drainage unit** that eliminates the need for barrier covers to prevent sand or fine soils from entering the drainage system. An alternative to gravel, the multi-pipe system couples together using standard 4-inch fittings. Its 1-foot by 10-foot by 12-inch diameter replaces up to 1,000 pounds of gravel. Made from recycled materials, the system meets the H1-0 load test, soil load test and hydraulic conductivity test.

**877/422-3569; www.iccflowtech.com.**



## TOWABLE BACKHOE

Whether uncovering septic lids or excavating in cramped quarters, the **Model 6L Go-for-Digger** towable backhoe from **R. H. & M Machine Co.** is a good fit for small jobs. The excavator has a maximum digging force of 4,500 pounds and digging depth of 108 inches. With an overall weight of 2,800



pounds, the backhoe offers 2,500 psi hydraulic pressure. The rubber-wheeled unit has a transporting height of 90 inches, 7-inch ground clearance and measures 77.5 inches wide. The bucket has 180-degree rotation, a loading height of 6 feet and loading reach of 59 inches. **304/296-7000; www.gofordigger.com.**

## HYDRO EXCAVATING

**Non Stop Hydro Excavating** introduced the **hydro excavator slurry separator**. The unit is designed to eliminate the downtime needed for slurry disposal or water loading. The system continuously separates the slurry into dry native soil that can be used for backfill, while the water is recovered for ongoing jetting. **403/346-0996; www.nonstophydroexcavating.com.**

## WASTEWATER TREATMENT SYSTEM

**Ecological Tanks Inc.** featured its **Aqua Safe AS500L-EZ aerobic wastewater treatment system**. The unit has a 20-inch polyurethane riser and 5-foot tall, low-profile aerobic tank. Its 55-inch inlet height is especially suited to rocky conditions or high water tables, with compressor and controls located under a polyurethane cover. **800/277-8179; www.etiaquasafe.com. ■**



## PICK-UP TRUX

**The Standard in Portable Sanitation!**

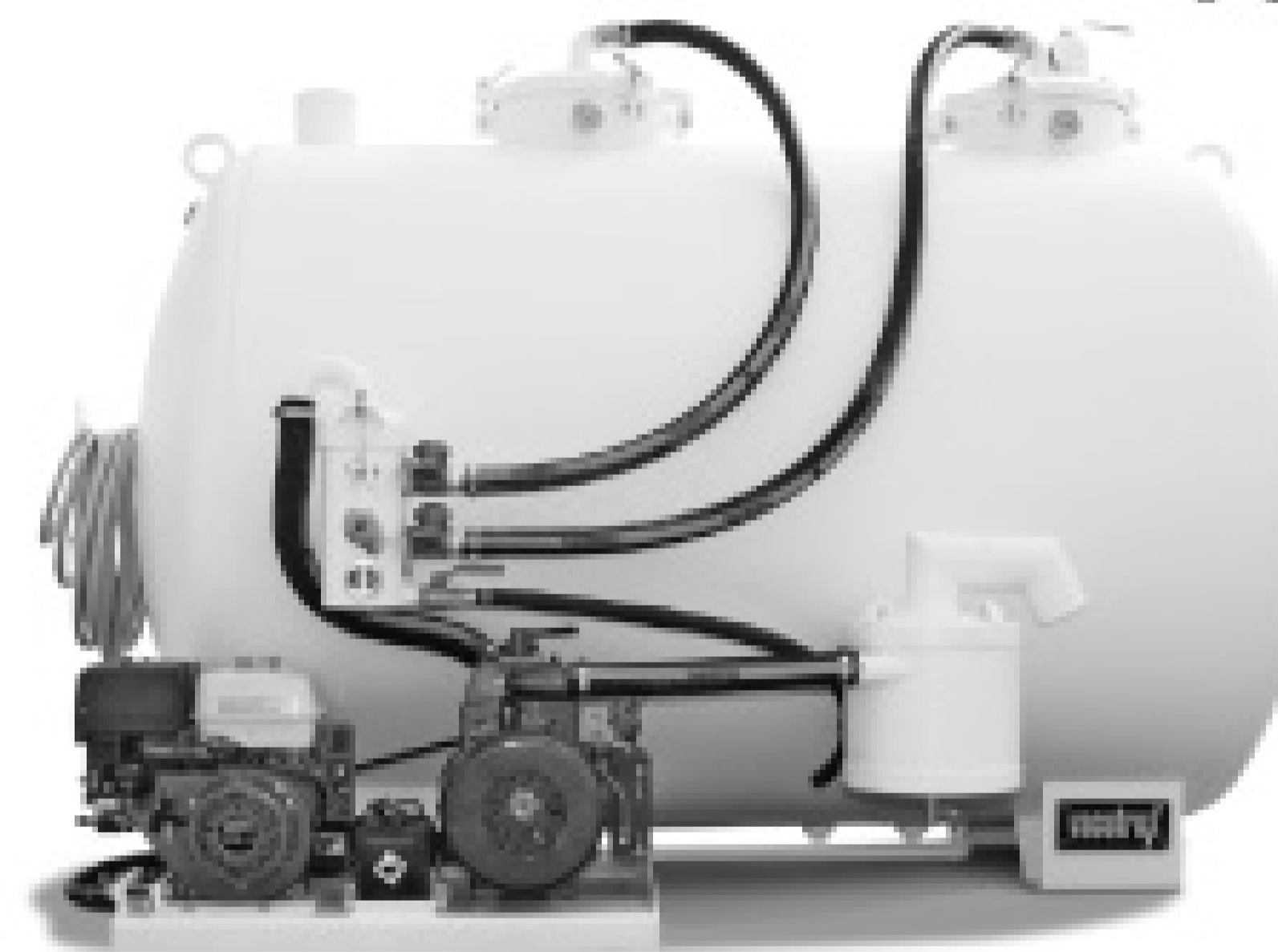

Dual compartment tank  
Dual vacuum systems  
Available in a range of sizes



Engine Drives

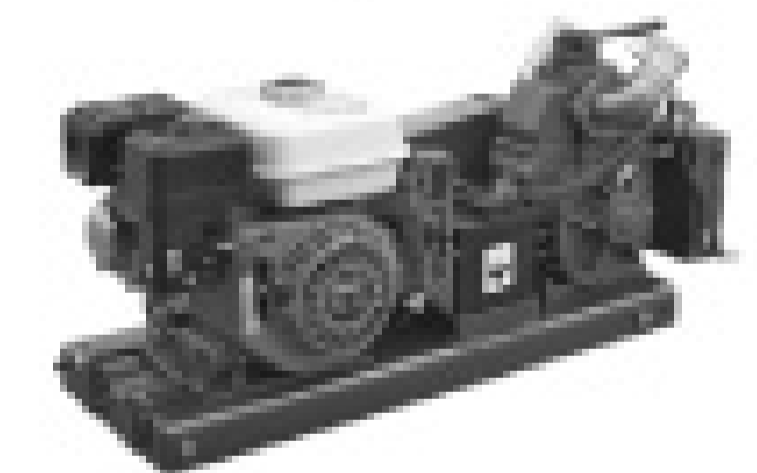

## TRAILER-MOUNT TANKS

Heavy duty trailer  
Engine driven pumps  
Built to your needs



**vacutrux**  
**800-305-4305**

**Louisville 2010**  
February 24-27  
[www.Pumpershow.com](http://www.Pumpershow.com)

A large advertisement for the Louisville 2010 Pumpershow. It features a large orange truck in the background, a crowd of people sitting at tables in the foreground, and a man in a green jacket standing in the middle ground. The text is in a bold, stylized font.

PORTABLE TOILET  
SERVICE UNITS  
SLIDE IN UNITS  
HOISTED UNITS  
ROLL OFF UNITS  
CUSTOM UNITS

[www.pikrite.com](http://www.pikrite.com)



Manufacturing & Sales - 60 Pik Rite Lane - Lewisburg, PA 17837

**1-800-326-9763**



**GET MORE JETTER  
FOR YOUR DOLLAR!**

We include all the options,  
others charge extra!

**UVJ Models**  
5 gpm @ 4000 psi  
Cold Water \$5995  
Hot Water \$7995

**NEW  
Models**



Don't see what you want?  
We do custom fabricate!

**Fully Loaded Models**  
7 gpm @ 4000 psi \$10199  
11 gpm @ 2500 psi \$11999  
15 GPM @ 3000 psi \$18399  
20 gpm @ 2000 psi \$19999  
18 gpm @ 4000 psi \$37899



See our complete lineup from economy models,  
van mounts, portables and more on the web at:

[www.camspray.com](http://www.camspray.com)

**800-648-5011**

## DISTRIBUTORS WANTED

**MAJOR ALUMINUM  
& STAINLESS STEEL  
TANK FABRICATOR**

**LOOKING FOR  
DISTRIBUTORS WITH  
MOUNTING AND  
SERVICE FACILITY**

CONTACT  
DON FREVERT

**MID-STATE TANK**

**800-722-8384**

[dfrevert@midstatetank.com](mailto:dfrevert@midstatetank.com)

**800-722-8384**



# VAC-CON

## PRE-OWNED EQUIPMENT

### MORE POWER TO YOU



**2005 VAC-CON V321LHAD**

- 2005 IH 7600
- CAT C-13 380 HP / 10-SPD
- 50 @ 3000 / DEUTZ 138 HP
- Mileage: 31,000

**\$195,500**



**1997 VAC-CON V312THAE/1300**

- 1997 Ford LNT8000
- 275HP / MD3060
- 50 @ 3000 Water Pump
- Mileage: 66,703

RECONDITIONED **\$120,000**



**2004 VAC-CON V390LHAD**

- 2004 International 7400
- IH 275 HP / Allison MD3060
- 50 @ 3000 / DEUTZ 138 HP
- Mileage: 11,000

RECONDITIONED **\$198,500**



**1998 VAC-CON VPD3612LHA**

- 1999 IH 2554
- 275 HP / Allison MD3060
- 80 GPM @ 2000 PSI
- Mileage: 116,000

**\$125,000**



**2006 VAC-CON V312LHAD**

- 2007 STERLING LT7501
- CAT 275 HP / Allison 3000RDS
- 50 @ 3000 / DEUTZ 138 HP
- Mileage: 23,000

**\$209,500**



**2000 VAC-CON VPD3609SHA**

- 2001 IH 2654
- 275 HP / Allison MD3060
- 60 @ 2000 / John Deere 4045T
- Mileage: Approx 45,000

**\$145,000**



**2001 VAC-CON V312LHAD/1300**

- 2001 Sterling LT9501
- CAT 380 HP / 10-Speed
- 80 @ 2000 / Cummins 110 HP
- Mileage: 73,000

RECONDITIONED **\$185,000**

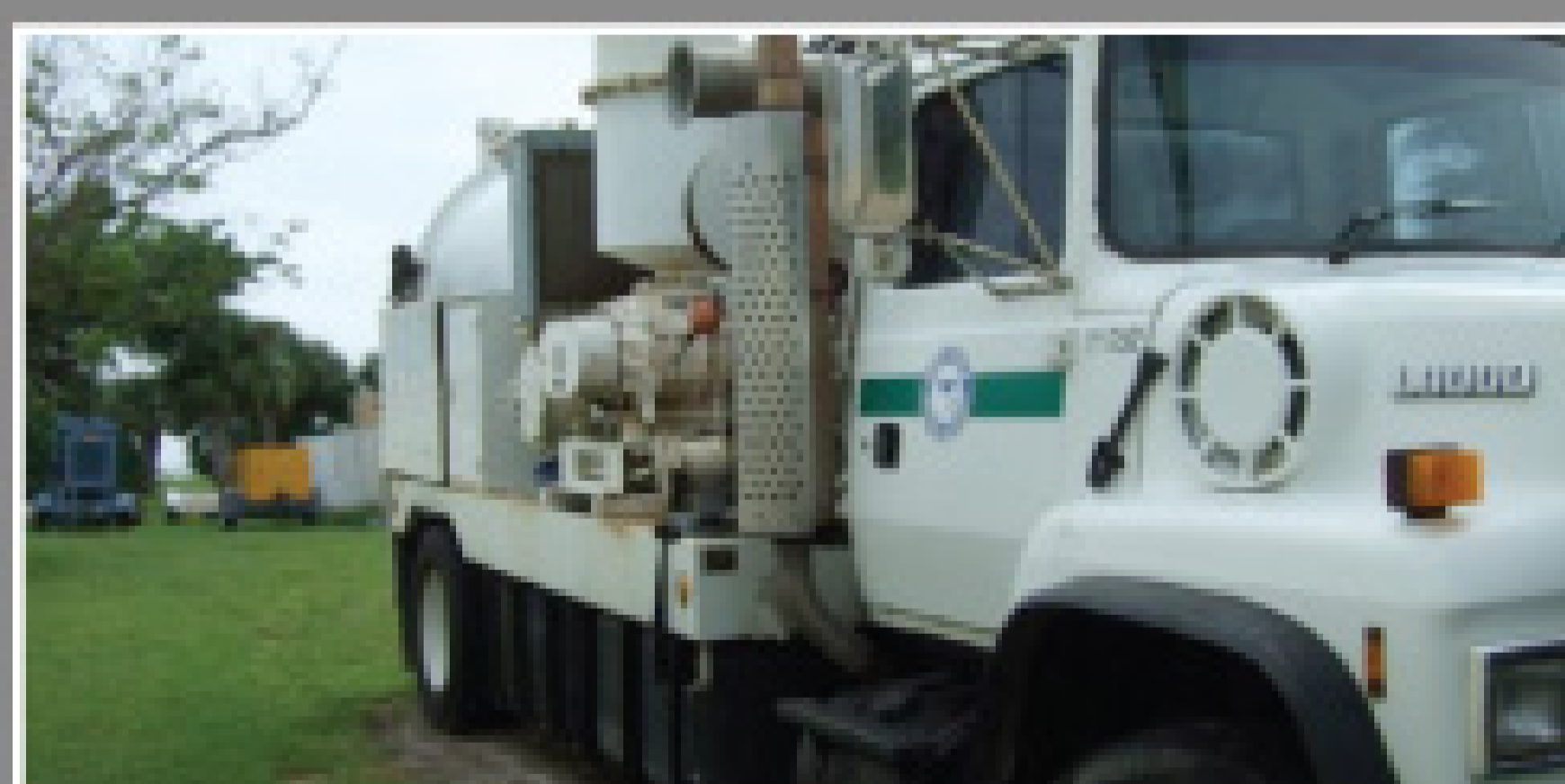

**1995 VAC-CON VPD3690THA**

- 1995 FORD LN8000
- Cummins 250 HP / Allison MD3060
- 30 @ 3000 / John Deere 4039T
- Mileage: 57,500

RECONDITIONED **\$95,000**



[www.vac-con.com](http://www.vac-con.com)

*Ultimate  
Lease*

Ultimate Lease Hotline:  
**888-817.1757**

969 Hall Park Drive • Green Cove Springs, FL 32043 U.S.A.  
Tel: 904-284-4200 • Fax: 904-284-3305  
[www.vac-con.com](http://www.vac-con.com) • [vns@vac-con.com](mailto:vns@vac-con.com)

# LELY

## Commercial Wastehandling Equipment

### Put Our Experience to Work for You

Aluminum Tanks • Full Open Door Hoist Tanks

ASME DOT 407/412 Code Tanks

- Standard and custom tanks
- Carbon steel and aluminum available
- A tradition of reliable service
- Large range of sizes (400 - 6000 Gal.)
- Complete line of parts



- 1) Vacuum and Pressure Relief Valves
- 2) Easy to Read Vacuum and Pressure Gauges
- 3) Balanced Tubular Pump Drive Shafts
- 4) Full Length Hose Trays
- 5) Get Tank Protection with Aluminum or Spray Liner
- 6) Low Profile Primary Shut-Off with SS Float Ball
- 7) 20" Top Manway
- 8) Three 5" Sight Glasses
- 9) Stainless Steel Boxed Upper ID Light Bracket with Truck-Lite Brand Lights
- 10) 24" Rear Manway with 4" or 6" Discharge with Camlock Fittings (up to 36")
- 11) DOT Approved Step Bumpers
- 12) 4 Anti-Sail Mud Flaps
- 13) Large Hose Hooks
- 14) 3" or 4" Intake
- 15) We carry blower packages for your heavy duty jobs

### Portable Toilet Trucks

Available On All Models

- Hot Shift PTO with Automatic Transmission
- Balanced PTO Axle
- Heavy Duty Toilet Carrier
- Trailer Hitch
- Spring Rewind Reel (Optional Dual Service)
- 2" Bucket Quick Fill
- Driver Side Work Station
- Dual Side Tool Box



- Electric Water Pump 40 PSI 6 GPM (Air Pressurized Optional)
- Coated Water Compartment
- Full Set of Working Lights
- Truck-Lite Lights
- 50 ft. Water Hose with Nozzle
- Vacuum and Pressure Relief Valve

5.5% FINANCING AVAILABLE.



Lely Manufacturing, Inc.  
 P.O. Box 789 Wilson, NC 27393  
**800.334.2763**  
 sales@lelyus.com

—partners in wastehandling—  
**www.lelyus.com**

## FACTORY AUTHORIZED SERVICE

for: **ROOTS-DRESSER, ROBUSCHI, HIBON, H&H, HOLMES and KAISER Blowers**

**Fast Delivery - Large Selection - Best Price - Great Service**  
**New - Rebuilt - Core Exchange**

**Exchange Units - Most Models of Roots, Robuschi, Hibon, Holmes, H&H and Kaiser**

- ◆ Roots 1125 Trinidad
- ◆ Roots 1021 DVJ
- ◆ Roots 1024 RAS
- ◆ Roots 1021 RAS
- ◆ Roots 824 RCS
- ◆ Hibon SIAV 840
- ◆ Hibon SIAV 8702
- ◆ Hick Hargreaves 4084

**New Blowers & Pumps Available From POWER VAC**

- ◆ Roots
- ◆ Robuschi
- ◆ Hibon
- ◆ Hick
- ◆ Masport
- ◆ Moro
- ◆ Aerzen

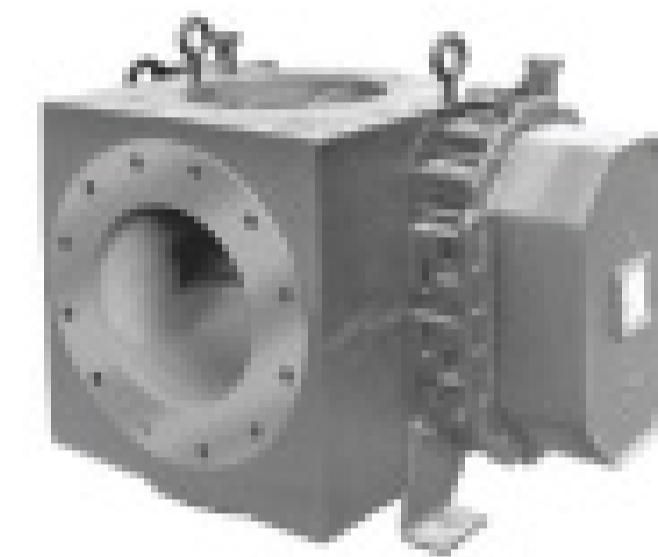

### 1-800-822-4887

W228 N2792 Duplainville Rd. • Unit G. • Waukesha, WI 53186  
 (262) 542-8989 • Fax: (262) 542-6262 • www.powervacinc.com

## "DON'T BE EMBARRASSED AGAIN!"

### HOW AWFUL...

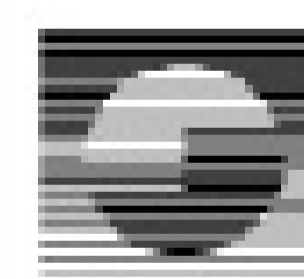

**800-622-8768**  
 sweetair.com

**SWEET SEPTIC SYSTEMS, INC.**  
 5701 Mother Lode Drive • Placerville, CA 95667  
 Fax: 530-622-1087

### SWEET AIR™ FILTERING DEVICE

### HOW WONDERFUL...



# The All-New Sunrise!



Durable, affordable with style that's out of this world.



**Hampel**

Engineered for strength, durability and value.

[www.hampelcorp.com](http://www.hampelcorp.com) • 800-549-1558

# GOOD TIMES in a Tough Economy



**Attentive management and smart diversification provide a recession-proof growth formula for California's Knight's Pumping and Portables**

*By Mary Shafer*

Knight's employee Miguel Fernandez services portable restrooms at a apartment construction site in northwest Bakersfield. (Photos by Alex Hovath)

**K**night's Pumping and Portables, a division of Knight's Services Inc. in Bakersfield, Calif., is seeing something fewer small businesses these days can claim: growth. Against the trend of contracting bottom lines, Knight's has created slow but steady expansion of its annual revenues.

Tracey Lince, vice president of business development, keeps a steady thumb on the company's financial pulse while turning a

watchful eye toward market developments. The large operation continues to thrive through a gut-wrenching economic downturn by serving strong customers, using technology to create operating efficiencies, and never losing sight of the fact that in the end, it's all about the customer.

#### FAMILY ROOTS

Jim Napier, Lince's father, retired from the California Highway Patrol and wanted to keep busy. So in 1982, he bought a used vacuum truck and began servicing residential septic systems. Before too

long, he got calls for portable restrooms, He started with 10 units and the business grew from there to requiring 35 trucks. In 1996, Napier died and his wife, Maureen Napier, took over the business. Their son, Mark Napier, came to work for his mother, and Lince joined the family firm in 2004 as administrative director in the office.

Today, Knight's still offers septic pumping, with a 40/60 split between residential and commercial customers. These are served by

## Profile

### **Knight's Services Inc.** Bakersfield, Calif.

**Owner:** Maureen Napier

**Founded:** 1982

**Employees:** 47

**Specialties:** Portable restrooms, septic tank and grease trap pumping, real estate inspections, temporary site services

**Service area:** Six counties in the San Joaquin Valley

**Affiliations:** Portable Sanitation Association International

**Web site:** [www.knightsservices.com](http://www.knightsservices.com)



**"OUR MOTTO IS 'DEPENDABLE, APPROPRIATE SERVICE.' THAT MEANS WE ONLY GIVE PEOPLE WHAT THEY NEED, NOTHING MORE. APPROPRIATE SERVICE BREEDS TRUST AND CONFIDENCE."**

**Tracey Lince**



The Knight's family includes (from left) Mark Napier, Tracey Napier-Lince and their mother, Maureen Napier. (Photo courtesy Knight's Services Inc.)

Jose Perez, a 10-year employee, empties a septic tank at the Orange Grove RV park in Bakersfield.



Miguel Fernandez cleans and fills a hand-wash station at a construction site. Knight's has more than 500 stations in its inventory.

four service trucks, all Freightliners with 3,600-gallon aluminum tanks from Progress Tank and HXL400 pumps from Masport Inc. This original service now only constitutes about 30 percent of gross billings, with another 10 percent coming from ancillary contractor services.

The bulk of the business — about 60 percent — is portable restroom rental and service. Knight's fields more than 3,000 single units. Most are Integra models from

PolyPortables Inc.; K2, Aspen and Maxim 3000 units from Satellite Industries. There are 30 ADA units from Five Peaks and Synergy World. These are joined by more than 500 PolyPortables TagAlong and SuperTwin hand-wash stations.

Running the routes are 12 trucks built by Glendale Welding, all equipped with 1,000-gallon waste/500-gallon freshwater tanks (aluminum on two, the rest are steel) and Masport pumps. Five GMC 4500 flatbed trucks, carrying 20 units each, are used for pickup and delivery.

#### TAPPING INTO SITE SERVICES

In the mild climate of the flat San Joaquin Valley, portables business hums along among

residential building construction (10 percent), commercial construction (40 percent) and special events (5 percent). But fully half of this volume serves the region's heavily populated agricultural areas and the booming oil field business.

"Oil field units are usually serviced twice a week," says Lince, "but that can be as often as daily." Knight's can have almost 300 units positioned in Chevron's fields alone. Agricultural units get serviced 2-3 times per week.

In 2000, Knight's realized one of its few competitors held the territory's entire temporary power market. With construction booming round the clock, contractors were asking for ways to light up the night. "We needed to be able to compete," explains Lince. They bought an existing electrical services company and began a calculated service diversification that kept Knight's a formidable competitor. "Customers had begun to ask for certain services, and we wanted to be their one-stop service supplier."

The company added roll-off container rental and transportation, construction and demolition waste removal and recycling, catch basin cleaning and maintenance, transportation and treatment of hazardous and non-hazardous liquid and solid waste, and waste management consulting, among other related services. This expansion also allowed a cushion against dropping demand for portables that Lince and the rest of her management team were certain would come when construction inevitably slowed.

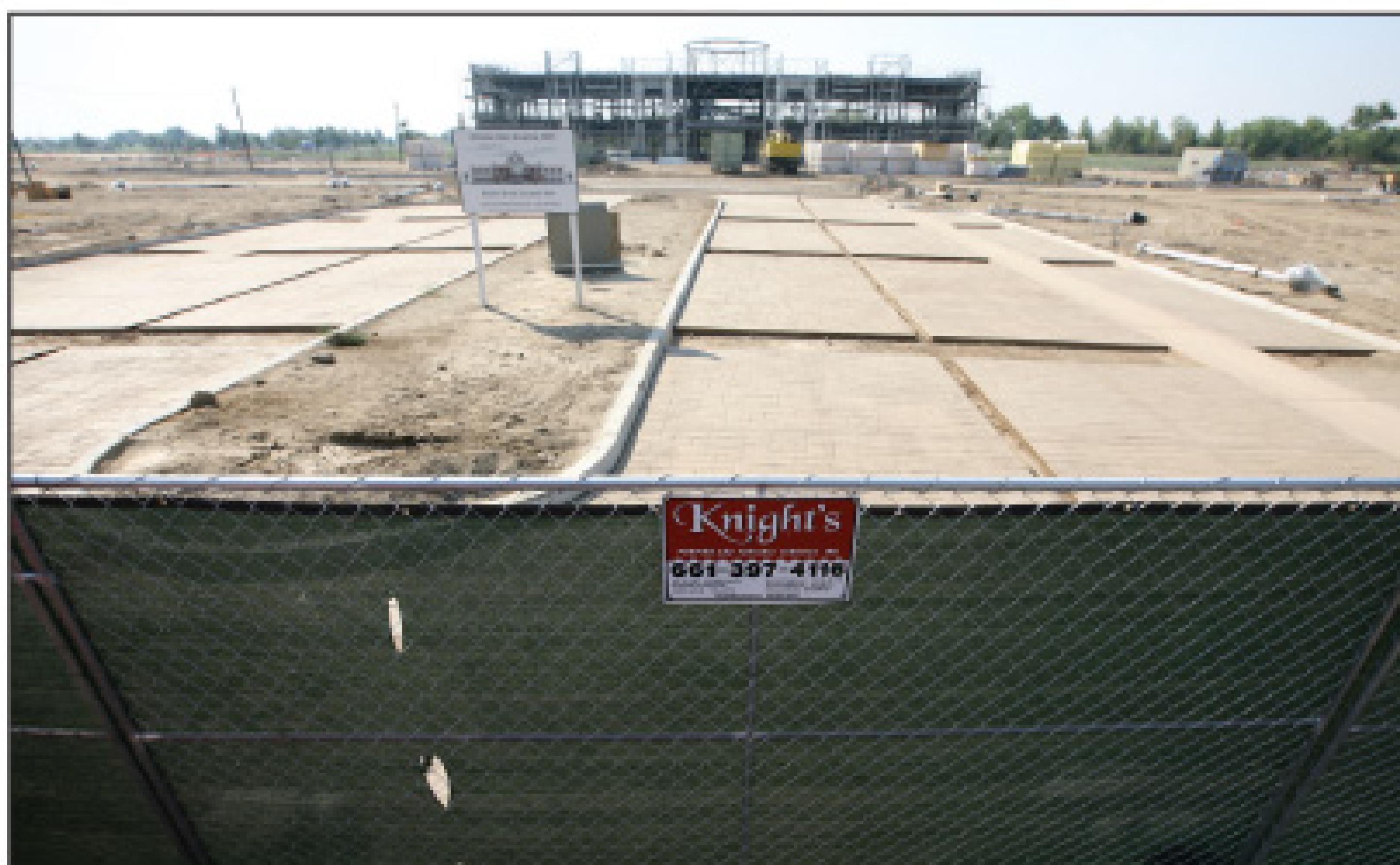

Knight's also supplies fencing for the Castle & Cook office complex in southwest Bakersfield.



**“WE WERE TOLD THAT THE MORE TRAILERS YOU HAVE AVAILABLE, THE MORE ORDERS YOU’LL GET, AND IT’S PROVEN TRUE.**

**IT IS PICKING UP. IT HASN’T HAPPENED OVERNIGHT, BUT WE NOW HAVE THEM LISTED ON OUR WEB SITE.”**

**Tracey Lince**

Miguel Fernandez cleans and services portable restrooms at a construction site in northwest Bakersfield. Portable restroom rental and service accounts for about 60 percent of Knight's' business.

### ROLLING TOWARD PROFITS

By 2007, “We’d gotten a few calls about restroom trailers, but we hadn’t seen one,” Lince says. “So that was our mission when we went to Louisville. Since residential construction had fallen, we hoped to pick up event business.”

At the 2008 Pumper & Cleaner Environmental Expo International, Knight’s management team toured candidates for the company’s first restroom trailer. They settled on a Presidential Series 20-foot model from Advanced Containment Systems Inc.

Almost immediately, the single trailer was rented on a year-long contract for a trucking yard. “So we got two Porta-Lisa solar-powered executive trailers — a 2008 and a 2009 model — from JAG Mobile Solutions. We were surprised at how quickly we rented them out, because we didn’t think they would go over well in this agricultural and oil area,” Lince admits. “We’re not in a big city where they have golf tournaments to support those kinds of needs.”

It wasn’t long before the company got calls from movie studios for trailers to serve shoots spilling over from Los Angeles. “On movie shoots, they like to be able to just pull it

around wherever it’s needed, so the self-contained solar unit made sense.”

The trailers’ success helped Lince’s team go out on a limb with the purchase of the second and third ones. “We were told that the more trailers you have available, the more orders you’ll get, and it’s proven true. It is picking up. It hasn’t happened overnight, but we now have them listed on our Web site.”

This marketing tactic paid off in their tech-savvy region, where many customers use the Web for research. “We actually got a huge order and had to borrow some from a colleague.” She says it has given rise to consideration of yet another trailer purchase.

Knight’s has offered a trailer on a complimentary basis to high-visibility events to introduce the concept and the company. “For the first year, we’re promoting them at a low price, and it’s helped,” Lince says. Knight’s is promoting through wedding coordinators and party rental firms, and is getting ready to create a large postcard to leave with clients.

Knight’s provides all portables for the Bright House performance amphitheater and the outdoor theater at the California State University of Bakersfield. They

serve an annual jazz festival and large religious gatherings there. Lince sees these venues as likely prospects for new trailer contracts.

### SAFETY FIRST

Serving boom markets has its downside. For oil field portables, this comes in the form of very strict safety restrictions. Chevron and Knight’s’ other oil company customers all have Injury and Illness Prevention Plans, or IIPPs, that must be followed to the letter. One infraction while on their property gives them the right to cancel any vendor contract.

“We were required to create a book that provides guidelines for our staff,” Lince says. “We have weekly safety meetings here, and at some facilities (such as refineries), only certain employees can go there.” These are staff who’ve been through a day of training and submit to random drug testing. A recent fatal



The Knight’s fleet includes four Freightliner vacuum trucks with 3,600-gallon tanks and 12 service vehicles with 1,000-gallon waste/500-gallon freshwater tanks. Flatbeds are used for hauling restrooms and fencing.



## Finding and retaining good employees

Tracey Lince says that, unlike many service businesses, Knight's Services Inc. doesn't grapple with the problem of getting and keeping quality workers.

"We've been pretty lucky getting good help," she says. "We got our current crew through a temporary agency. We hired them as temps to try them out, then kept or let them go according to their performance."

Lince paid attention to the books during the early stages of working with the temporary agency, and realized that testing, then hiring workers through the 90-day probationary period with the agency was costing the company a lot of money. So Knight's tried out the workers as long as they needed to test compatibility and skill levels, then hired them. This saves agency fees and helps bolster a strong benefits program, which includes 50 percent paid medical, a 401(k) year-end match and paid vacations.

Once they have employees, Knight's tends to keep them. "We haven't had trouble hanging on to good people. Our business consists of a lot of prevailing wage jobs," Lince says, explaining that any job worked on or for a public-funded project in California is highly paid at a state-set level. This situation evolved from a huge increase in school building that's been under way for several years.

Any vendor supplying these sites is affected by the prevailing wage requirement. A state certified payroll program requires reports proving payment of prevailing wages. "Many contractors don't even want to deal with the paperwork, but in a market like this, you can't afford to be that picky," Lince says. "We pretty much don't turn any work away."



Knight's office staff includes (from left) Tracey Lince, Diana Anaya, David Delgado, Sharon Connelly, Heather Waugh, Hilda Robles and Mark Napier. (Photo courtesy Knight's Services Inc.)

for the entire year if there are any injuries.

### ROUTE EFFICIENCY

Fuel prices have been a challenge in the not-too-distant past. "We're trying to be more efficient with our routing, being tough on overtime, and making sure to deliver and pick up units along a pumping route. If customers are willing to wait so we can schedule this way, we give them a price break so we can all save some money."

To aid in implementing such efficiencies, Knight's depends on the TAC (Total Activity Control) Mobile software package from Clear Computing Inc. for customer management, routing and billing. Sales data gets trans-

ferred at month's end to a Solomon accounting package (now called Microsoft Dynamics SL) for payables and general ledger entries.

"We meet with our financial advisor to go over month-end numbers, upcoming jobs, forecasting for sales projections, general and administrative overhead, and the cost of goods sold," Lince says. "We've been doing this for a year now, using the reports generated by our accounting package. It's a lot of work to prepare, but we were nervous about the way the economy was going, and wanted to arm ourselves with as much information as we could get. We're doing everything we can to see things before they happen. This way, you can do layoffs ahead of time if necessary, and stay out in front of things."

### APPROPRIATE SERVICE

Lince admits that forecasts and numbers are still estimates, and that nothing is carved in stone. "I don't know if anybody really knows what's going to happen. I don't think (the construction economy) will ever be booming like it was, but I think it'll come back. Until then, we'll continue our focus on the oil and construction markets as a foundation, and building the special events on top of that. You have to be conservative and do things on a small scale to start with."

In the back of her mind as she plans for the future, Lince says, is "the whole green movement. It's going to make a difference in waste and how it's processed. That's something to watch, because we'll all be affected."

Meanwhile, Lince realizes success is about people and relationships. Though large, Knight's' service area still has a small-town mentality in that people try to support local businesses, and she stresses this angle in her sales pitch.

"Our motto is 'dependable, appropriate service.' That means we only give people what they need, nothing more. Appropriate service breeds trust and confidence." ■

### MORE INFO:

**Advanced Containment Systems Inc.**  
800/927-2271  
www.acsi-us.com

**Clear Computing**  
888/332-5327  
www.clearcomputing.com

**Glendale Welding**  
623/937-7414  
www.glendalewelding.com

**JAG Mobile Solutions Inc.**  
800/815-2557  
www.jagmobilesolutions.com

**Masport Inc.**  
800/228-4510  
www.masportpump.com

**PolyPortables Inc.**  
800/241-7951  
www.polyportables.com

**Progress Tank**  
888/543-2121  
www.progresstank.com

**Satellite Industries Inc.**  
800/883-1123  
www.satelliteindustries.com

accident by another vendor causes this situation to be watched very closely.

Operations manager David Delgado also serves as Knight's safety officer. Each week, he covers a different topic with employees, such as safe lifting techniques, use of personal protective gear, or recent events. If there has been an on-the-job injury, he goes over it to discuss how it can be prevented in the future.

Knight's has dealt with a high incidence of such injuries due to lack of attention on the part of employees, something Lince calls "one of our biggest challenges. Even a finger slammed in a door is still a workers' compensation issue. Or stepping out of a truck into a pothole and twisting an ankle. It's really just a matter of staying alert, and we knew we had to encourage that attitude." So the firm offers a quarterly safety bonus, which is taken away

# Longhorn Tank Co.

The Solution for All of Your Pumping Needs



130 bbl Steel Trailer



7,000 Gallon Aluminum Trailer

Call or Email Us For a Quote Today

800-422-9840

sales@longhorntank.com

PO Box 1147 Gravette, AR 72736

Fax 479-787-6935

## NUCONCEPTS

MANUFACTURER OF QUALITY PORTABLE RESTROOMS AND SINKS



### Dual VIP Restroom Trailer

From \$9,841

**Ideal for:**

- Weddings / Parties
- Sporting Events
- Food Festivals
- Community Events
- Restroom Remodeling
- Movie Production

**Features:**

- Solar Powered
- Self-contained
- Flushing, china toilet
- Enclosed sink
- Power Converter (option)
- Air-conditioning (option)
- Interior Heater (option)
- Sink Water Heater (option)



1737 S. VINEYARD AVENUE • ONTARIO, CA 91761

PHONE 909-930-6244 • TOLL FREE 800-334-1065 • FAX 909-930-6237

www.NUCONCEPTS.com

## ART'S TRUCKS & EQUIPMENT

View Our Entire Inventory Online: [www.artstrucks.com](http://www.artstrucks.com)

3001 West Expressway 83  
McAllen, Texas 78503  
956.686.2326 Fax 956.686.5179

1.800.292.7007

[www.artstrucks.com](http://www.artstrucks.com)



**1999 VOLVO Combo Sewer Truck,**  
VOLVO-275HP Diesel Engine, Allison 3560 Automatic Trans., A/B, A/C, 55,604 Miles, Vac-Con Sewer Cleaner, John Deere Rear Diesel Eng., Lot #2815680 - \$65,000

**1996 GMC Sewer Truck,** CAT 3126 Diesel Engine, Automatic Transmission, A/B, A/C, VACTOR 2100 Combo Sewer Cleaner, 145,054 Miles Lot #2915854 - \$69,500



**1993 VOLVO Combo Sewer Cleaner,** L-10 Cummins Diesel Engine, Automatic Transmission, A/B, Combo Sewer Cleaner, 115,140 Miles, Lot #2815813 - \$39,500



**2002 STERLING Combo Sewer Cleaner Truck,** CAT 3126 Diesel Engine, Automatic Transmission, A/B, A/C, Vac-Con Sewer Cleaner, J. Deere Rear Diesel Engine, 44,391 Miles, Lot #2815806 - \$75,500



# Building A World of Solutions

Blower Repair



Waterblast Rentals

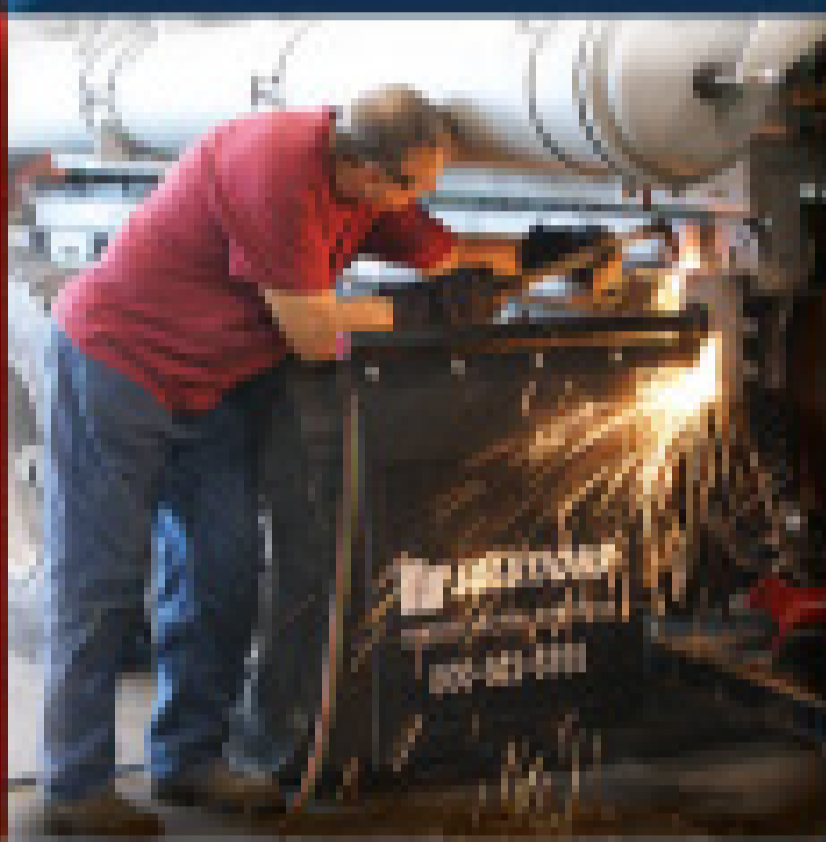

Equipment Refurbish



Parts



Used Equipment



Accessories

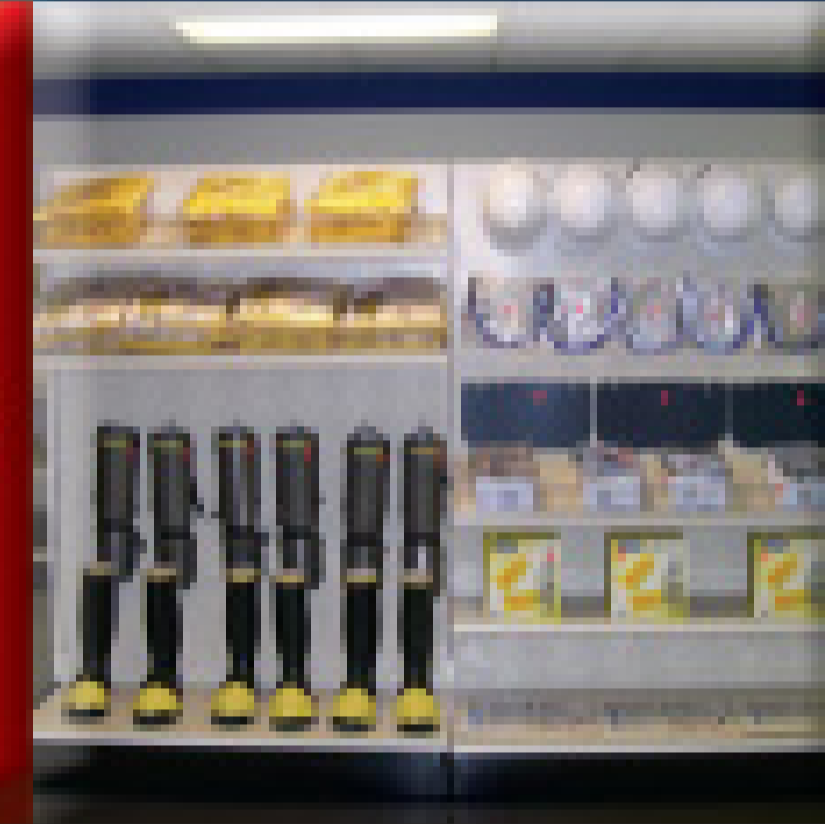

Training



## Huge Selection of Used & Refurbished Trucks!



Unit #M1334 2009 Sterling 7501,  
 New Guzzler Predator, 3,000 Gallon  
 Debris Tank  
**READY TO WORK!**



Unit #44185 2005 International 7600,  
 2008 Guzzler Classic, New Vacuum  
 System, HIBON SIAV 8702 27" Blower  
**READY TO WORK!**



Unit #12085 2002 Sterling LT9500,  
 Guzzler Classic, New Paint, Roots  
 Trinado Blower 27"  
**READY TO WORK!**

Many More Units Available • Warranties for Most Equipment we Sell and Service

**1.800.822.8785** [www.fssolutionsgroup.com](http://www.fssolutionsgroup.com)



# wallenstein septic pumps

CALL FOR PRODUCT LITERATURE  
AND  
YOUR NEAREST AUTHORIZED  
DISTRIBUTOR

- > Quality construction
- > Rugged design
- > Wide fiber vanes
- > Easy internal access
- > Low noise level
- > Two year warranty



220 CFM



275 CFM



350 CFM

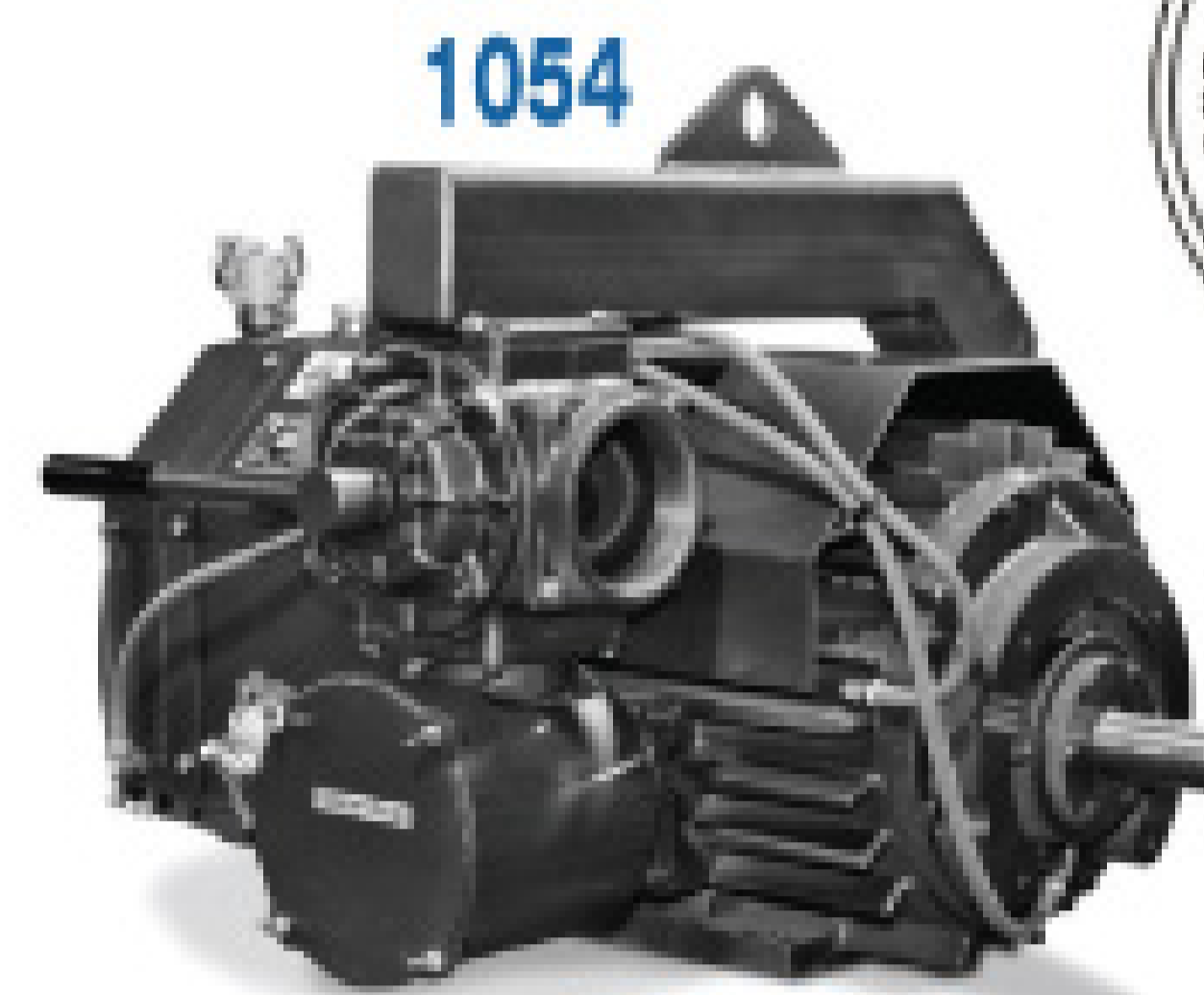

500 CFM



Series	Rating CFM	Vacuum "HG	HP <small>min of Diesel Engine</small>	Tank Size US Gallon
403	220 @ 1150	27	18	2000
553	275 @ 1150	27	24	2500
753	350 @ 1150	27	30	3500
1054	500 @ 1000	27	40	5000+

Toll Free 1-800-801-6663 fax 519-669-8331 email [info@wallensteinpumps.com](mailto:info@wallensteinpumps.com)

## SmithCo SIDE-DUMP TRAILERS

# SIDE DUMP

Call 800-779-8099  
[www.sidedump.com](http://www.sidedump.com)

30902 C38  
Le Mars, Iowa 51031



CP-20 Offroad



SHV Series



DT Series



MHV Series



S Series

Manure, Slurry, Sludge, Green Waste, Food Residuals, Compost, SmithCo Hauls it All.

Stock Pile, Spread, Stability, Selection, Service...SmithCo

ALUMINUM, STEEL and  
STAINLESS TANKS manufactured,  
assembled and serviced by quality  
Imperial employees!



**IMPERIAL**  
INDUSTRIES INC.  
800-558-2945



*Over 28 Years of  
Custom Tank Manufacturing  
The Proud Tradition Continues....*

**CUSTOM MANUFACTURED TANKS IN  
STEEL, ALUMINUM AND STAINLESS**

- STOCK UNITS:**
- (1) 2009 I.H. / 4000 Gal. Aluminum Tank
  - (1) 2008 Peterbilt / 4000 Gal. Aluminum Tank
  - (1) 2009 Peterbilt / 4000 Gal. Aluminum Tank
  - Ready For Delivery (Call For Details)

- STOCK TANKS:**
- 2500 Gallon Steel & Aluminum
  - 3600 Gallon Steel & Aluminum
  - 4000 and 5000 Gallon Aluminum

Call Jim Stieber or  
Randy Tischendorf  
for details!

**Introducing the  
"Imperial  
Tradition"**

**Call us for information on  
the "Imperial Tradition,"  
Wash Stations and  
Chemicals for 2009**



- Slide-In Units and  
Service Truck Units  
of various capacities  
In-Stock!



**V&H AUTOMOTIVE**  
Marshfield, WI 54449  
Mark King

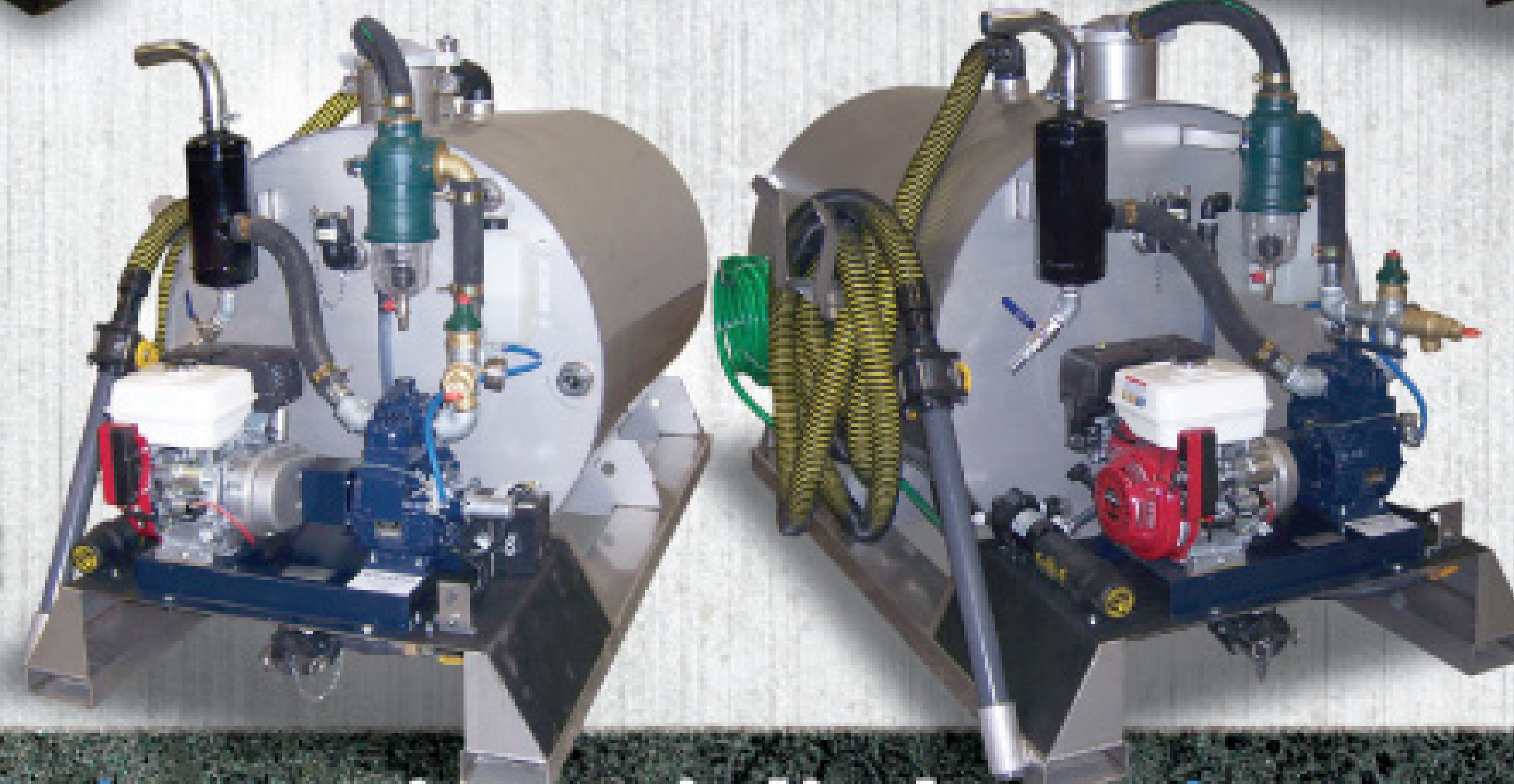

**IMPERIAL**  
P.O. Box 1685  
Wausau, WI 54402

800-722-7382, ext. 244 | [www.imperialind.com](http://www.imperialind.com) | 800-558-2945, ext. 317



- **Advanced Training Seminars**
- **Creative Financing**
- **Marketing Assistance**
- **Industries Best Product Warranties**
- **Exceptional After Sales Support**

[www.satelliteindustries.com](http://www.satelliteindustries.com)

# *Flight To Quality* **Flight To Quality**

The competition for business is at an all time high and those who focus on quality will survive. At Satellite, our focus has always been to provide top quality products that stand the test of time and make you more profitable.

Satellite, along with our Area Managers, deliver more than quality products. We also offer our customers personalized service developing money saving procedures like improving route efficiencies, creating a profit and loss statement, evaluating GPS cost benefits, ideas for marketing your company and much more.

Quality is a choice and with Satellite you have unlimited opportunities to improve your business. Call one of our Area Managers today or a Customer Service Representative to learn more.

Call Toll Free:

**800-328-3332**

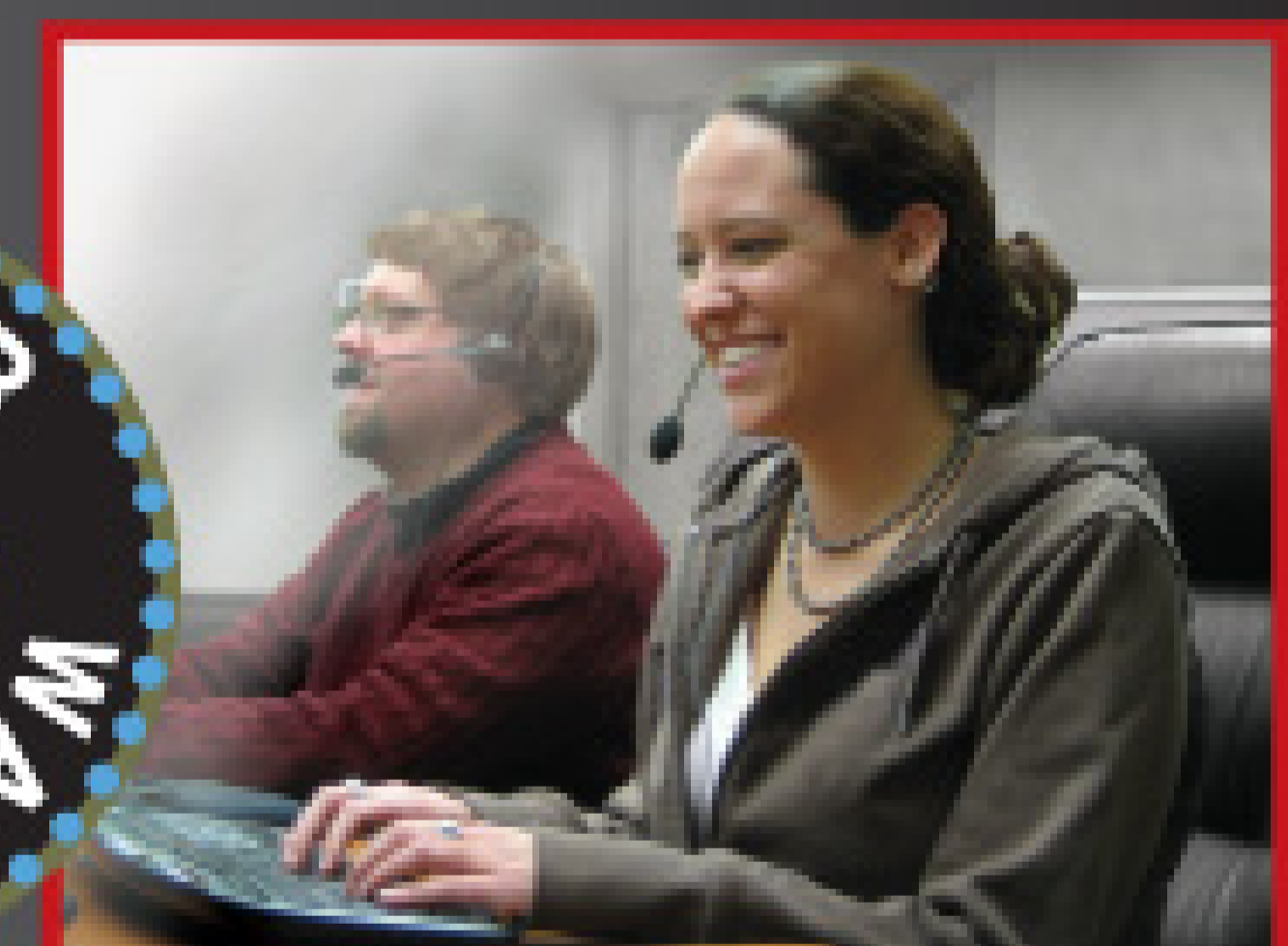

*Imagine The Possibilities*

Peter Venegas (left), performing his duties as a bail bondsman, consults with a client and his attorney.



## ON THE CASE

With an entrepreneurial streak as long as a drive across Texas, Peter Venegas is proud to head up several successful companies — among them is South Texas Waste Systems in Laredo. His portable restroom company may be just one piece of his business pie, but it seems obvious that Venegas has a knack for providing necessary services others might not want to provide.

Venegas Bail Bonds, one of his ventures, is proof of his versatility. As a bail bond agent, Venegas will charge a fee to a criminal defendant and then pledge a substantially larger sum of money as bail for them. He is then responsible for making sure the defendant shows up for scheduled court dates. If the defendant doesn't show up in court, Venegas loses the pledged money. With a state license to post bonds up to \$4 million, Venegas has worked in the trade for almost 16 years, mostly servicing drug cases on the Mexican border.

"I run my office from my (portable sanitation) yard. It's been a very good business," says Venegas, 39, who adds that it's possible to make \$50,000 in just one hour on a major case. "It depends on your reputation," he says. "Having 15 years on your back helps a lot."

### FROM RESTROOM TO COURTROOM

Venegas, an American of Mexican descent, started his portable sanitation business as kind of a fluke. In 2004, when a partner backed out of a planned waste management venture, Venegas had the equipment (front loaders, roll-offs and two dozen Satellite

Industries Inc. units), so he branched off into portable sanitation.

"When I started," he says, "I started from scratch, but then I bought several companies." He says the Laredo area — which has a population of 237,000 — was probably too small to accommodate several restroom vendors. Buying several of his competitors helped.

A few years later, Venegas now has more than 400 units (from manufacturers including Satellite, Hampel Corp., PolyJohn Enterprises Corp. and NuConcepts). "I'll be honest," he says, "You open a business and you expect it to do well, but it's been a difficult market."

That's why in a struggling economy, Venegas considers his bail bonds job his "bread and butter."

Looking for a new business venture, Venegas' attorney suggested he try bail bonds, but at first he balked. "At first, I was afraid of dealing with the convicts," says Venegas, now one of the self-proclaimed biggest drug bailsmen in Laredo.

Venegas said the bail bonds business is laden with pure adrenalin.

"I like the action, the excitement," he says, adding that honesty is the key to maintaining a successful business.

### NUTS AND BOLTS OF BAIL BONDS

After being imprisoned, offenders have access to a list of members of the Professional Bondsmen of Texas, the association to which

## Tex-Mex border portable restroom contractor balances sanitation services and bail bonds business



South Texas Waste Systems won the Laredo Chamber of Commerce Five Star Customer Service Award for hospitality. Pictured with the award (from left) are Margarita Guajardo, Ana Pacheco, Cristina Alarcon, Rogelio Samaniego, Joyce Neira, Wimberly Venegas, Peter Venegas, Omar Gonzalez and Gerardo Quintanilla.

Venegas belongs. When Venegas is contacted, he visits the jail and discusses the terms with the offender — who must put up collateral to cover the amount of the bond — which can reach into the millions depending on the violation.

"They pay me, I pick them up. I'm there to help them, give them a service," he says.

"People will pay you anything for freedom," says Venegas, adding that he might charge a client \$100,000 to \$200,000, depending on the amount of their bail. "When they come to you with a problem, you can charge whatever you want."

The biggest worry of any bail bondsman is having a client miss their court date. But while Venegas admits he has had offenders jump bail, he says that's an infrequent occurrence. Still, it's a possibility he lives with every day. He has the option of hiring a bounty hunter or local police to track down the offender. That's important because without the offender, the money Venegas puts up is in jeopardy.

"The government never loses," he says. "If





Turquoise units from South Texas Waste Systems are set up for a special event at the Laredo Civic Center.

the convict doesn't show up, they're going to call me." Ultimately, if the offender doesn't appear in court, Venegas is responsible to pay "whatever the judge decides. That's why I need to have collateral."

Unlike his portable restroom business, Venegas' fees for bail bonds service vary quite a bit.

"I can charge whatever I want; it depends on how risky the case is," he says. Often, cases involving a large volume of drugs may require a higher bond — "not necessarily always, but most of the time."

The risks of the job — dealing with potentially dangerous clients and having the offenders jump bail — are obvious. But that's why Venegas says he is choosy about his clients. "I try to pick my people," he says. "I don't take everyone."

"One of every 10 to 15 cases gets depressing," says Venegas, who after 15 years is adept at reading people, their personalities and their motivation. "I can decide if I will take someone just by hearing them on the phone."

The nature of Venegas' business has him dealing with several repeat clients, but he hastens to add that despite their digressions, they are not all "bad people."

"They've been caught once, twice, three times; that's their 'job.' You'd be surprised

what kind of people they are. They think they can get away with it," he says.

### ULTIMATE MULTI-TASKER

When he first started the bail bonds business, Venegas made himself available 24 hours a day. But these days, with a wife, three kids and a portable restroom business to watch, his time is a bit more divided.

Both businesses are demanding, but Venegas credits his employees at South Texas Waste Systems for keeping things running smoothly on the sanitation front.

"I have good employees, and we try to manage everything the right way," he says, adding that his wife, Wimberley, an eighth-grade teacher, recently took on oversight of the restroom business — a move Venegas hopes will allow South Texas Waste Systems to pick up more business. "That's what we're planning," he says. "She's actually learning the business from the inside, getting in from the bot-

tom, learning to route, how to sell, how to talk to people."

South Texas Waste Systems has faced its challenges. "With the economy, it's not going so well," Venegas admits. Still, while he doesn't have expansion plans right now, he remains positive about keeping current customers happy by providing impeccable sanitation service.

A tenacity and can-do attitude is necessary to succeed in both of Venegas' businesses, where the hours are long and unusual and the thank-yous are few.

"Every business has risks," he says. "A lot of people ask me, 'Is (bail bonds) a good business?' My answer is, 'Everything is a good business.' It's the way you manage it and have control." ■

*After Hours is an occasional feature that describes how business owners reconcile work life with family, leisure time, charitable pursuits, and personal interests and passions. Pumper welcomes story ideas. If you take part in something interesting outside work, or if you know someone in the pumping business who does, please send a note to editor@pumper.com.*

## Software to Keep Track of your "Business"

DATAsan

- Billing, Invoicing & Accounts Receivable
- Service Route Mapping Integration
- Equipment Installation / Service Tracking
- Instantaneous Item Search & Retrieval
- Scheduling / Dispatching

HORIZON INFORMATION SYSTEMS  
Toll Free: 1-800-889-3388 | Email: info@horizon-is.com

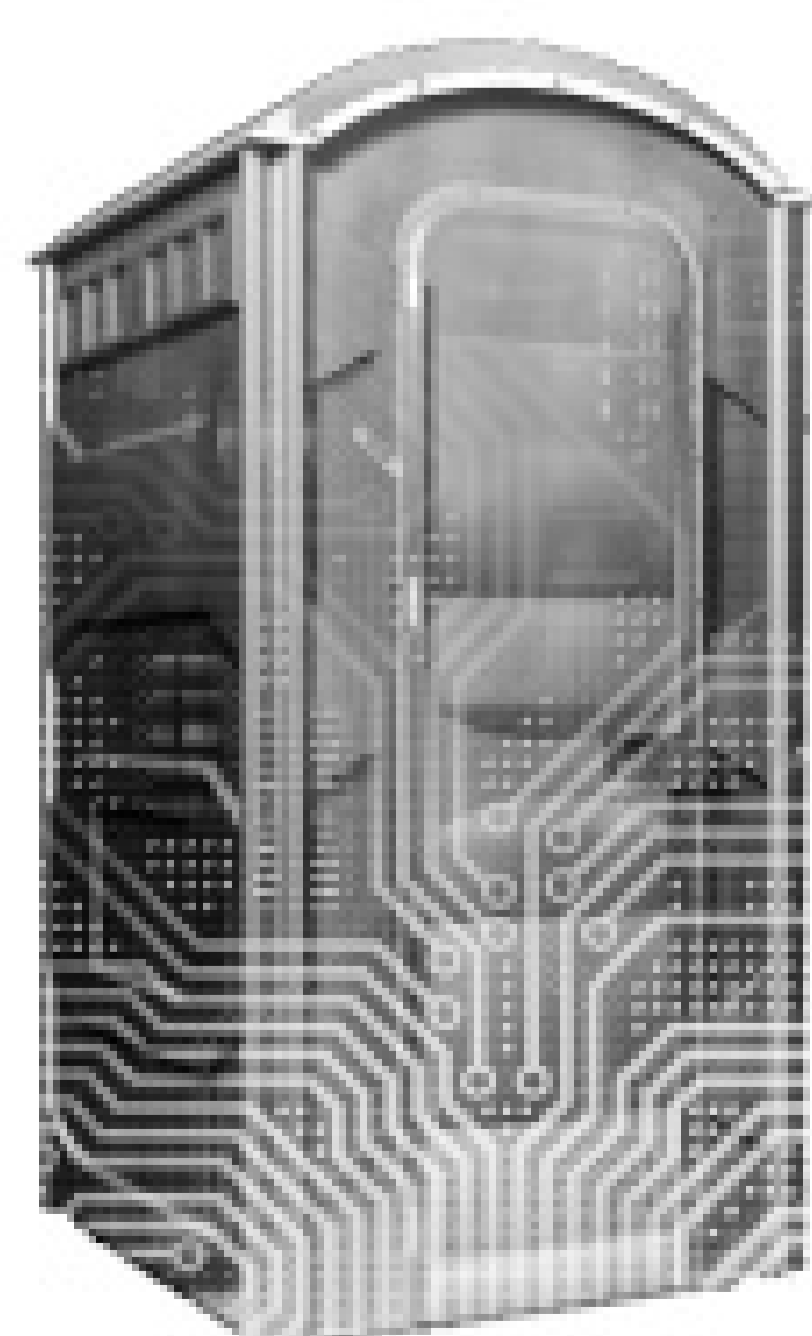

**Daily • Weekly • Monthly Rentals • Rent-to-Own**  
Our goal is to ensure that every pre-owned or rental unit we offer provides the most value for your money.



**STANDARD**

800-633-2997  
www.standardequipment.com

**Rebuilt  
&  
Rental**

# 27th TRUCKS INC.

WORLDWIDE EXPORTERS

8975 N.W. 27TH AVE. • MIAMI, FL 33147 • TEL: 305.835.9030 • EMAIL: INFO@27TH-TRUCKS.COM

2 Year  
Factory Warranty  
on Pumps

5 year Factory Warranty  
on Carbon Steel Tanks

10 Year Factory Warranty  
on Aluminum Tanks



**2005 MACK VISION**  
4000 Gallon Steel Tank



**2004 MACK VISION**  
4000 Gallon Carbon Steel Tank,  
Less Than 300K Miles  
2 In Production

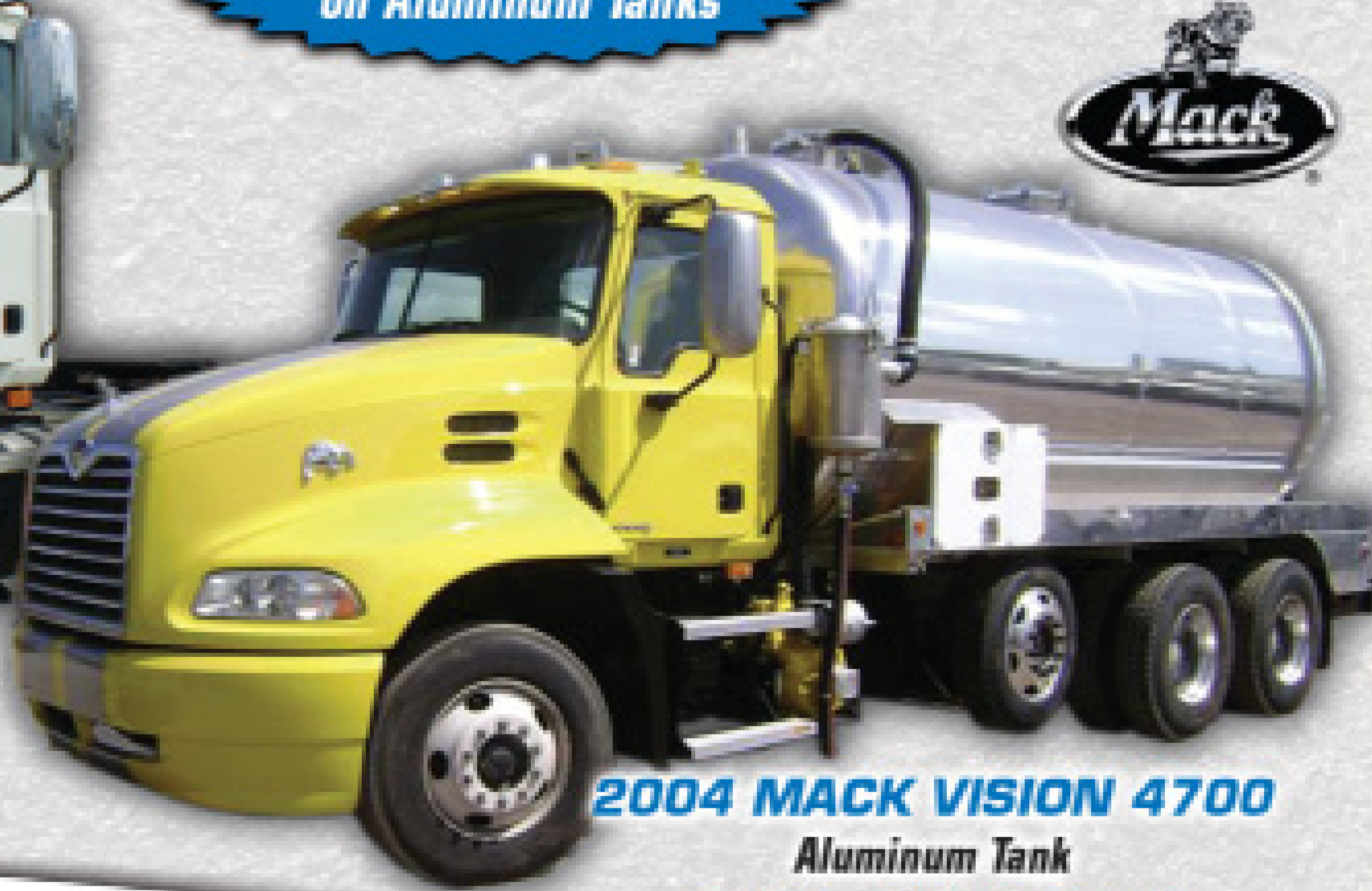

**2004 MACK VISION 4700**  
Aluminum Tank

**SOLD - THANK YOU**  
Bub's Inc.

**IN PRODUCTION**

**2005 Mack** 4000 Gallons, Dumping  
**2003 Mack** 3600 Gallons (\$65,000)  
**2005 Mack** 4000 Gallons

**1999 Mack** 3600 Gallons (\$49,000)  
**1999 Mack** 2500 Gallons (\$39,000)

**WWW.27TH-TRUCKS.NET**

Contact Alan @ 305-457-8058, Armando @ 786-267-3026, David @ 786-236-9007

Irrigation fittings are for irrigating – NOT vacuum.  
How many dollars are you spending  
**SUCKING AIR?**  
Industry-proven, quality vacuum couplings from  
Bandlock will put money into your pockets.

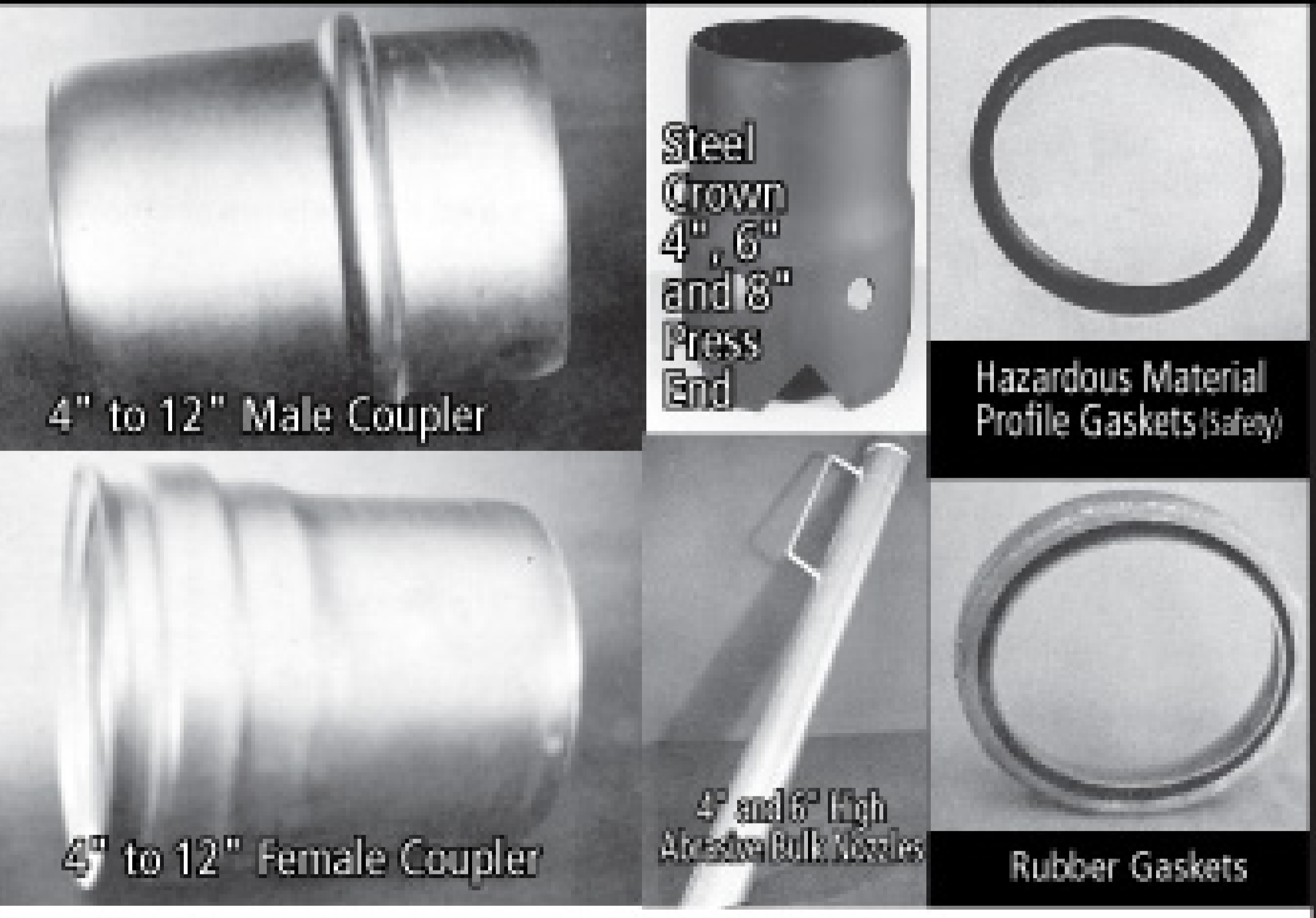

4" to 12" Male Coupler

Steel Crown  
4", 6"  
and 8"  
Press  
End

Hazardous Material  
Profile Gaskets (Safety)

4" to 12" Female Coupler

4" and 6" High  
Aluminum Bulk Nipples

Rubber Gaskets

**Recognized  
as the  
#1  
Relief Valve  
in the  
World**

CLOSE TOLERANCE  
COUPLERS AND  
FITTINGS BRING  
"SAFETY" TO  
YOUR WORK  
PLACE.

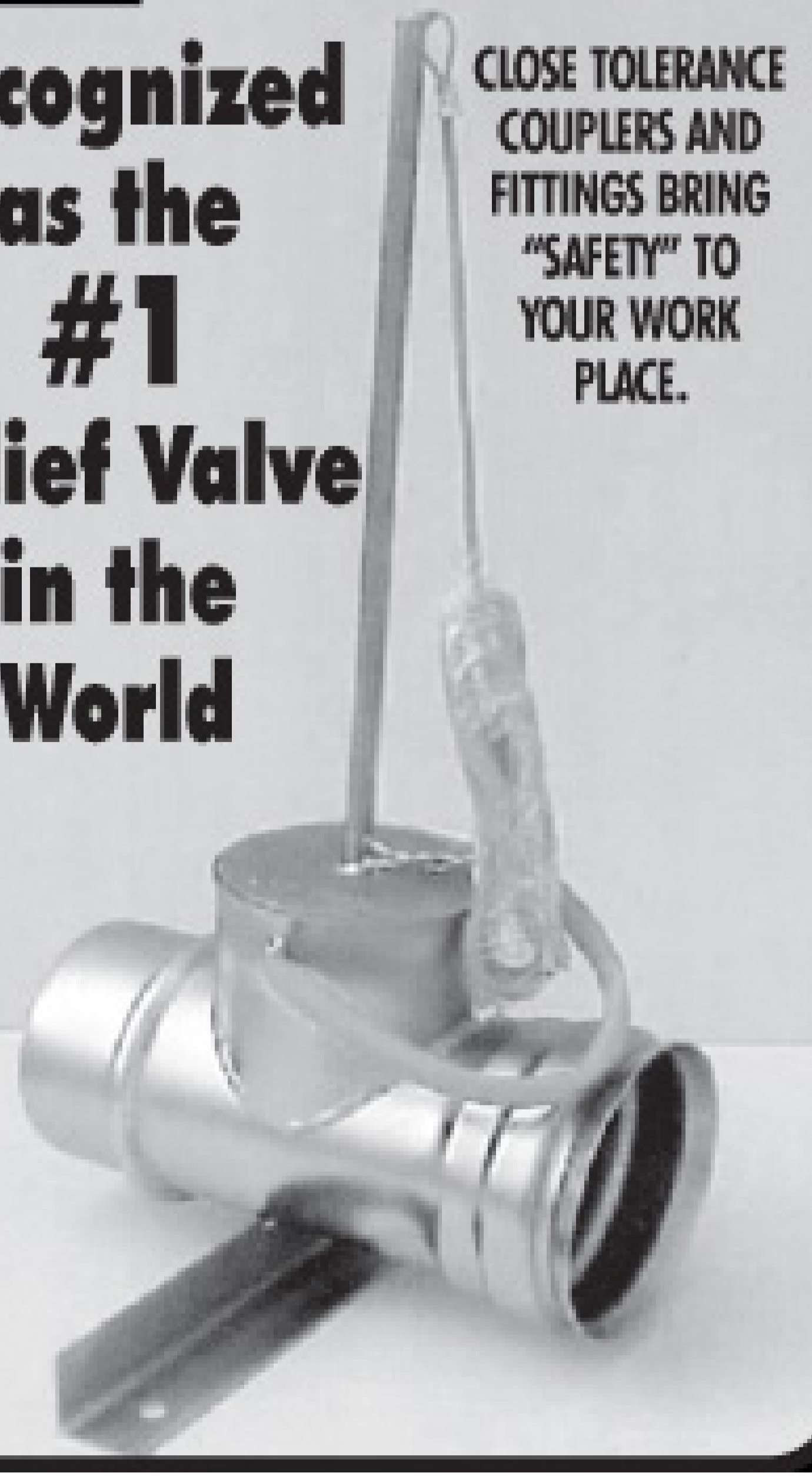

Special "Y" Reducers

BANDLOCK "Y"'s

Aluminum & Steel Pipe

BANDLOCK Reducers

Wet Valve, 6",  
360° Injected

Male and Female  
4" to 12" End Plugs

EZ Lift Clamps

Standard & Internal  
4" to 12"

**BANDLOCK Corp.**  
MADE IN THE U.S.A. [www.amesbury.com](http://www.amesbury.com)  
Call or fax today to get your catalog!  
**1-800-659-2978**  
**Fax: 909-930-2551**  
SUPERIOR "QUICK" CONNECT VACUUM AND PRESSURE COUPLINGS AND ACCESSORIES



**part·ner** |'pärtnər| **noun.**

*one that is **united** with another in an activity or sphere of common interest, especially a member of a business partnership*

**com·pet·i·tor** |kəm'petətər| **noun.**

*any trailer manufacturer who competes with its own customers on restroom trailer, shower trailer, or plastic portable toilet rentals*

*JAG Mobile Solutions, THE DEFINITION of a good partner.*

**Providing QUALIFIED lead referrals to members of  
the JAG Owner Network**



Restroom Solutions  
Shower Solutions  
ADA Solutions  
Solar Solutions  
Industrial Solutions

• 24 Hour Support 304-210-5999 JAG President, cell  
704-287-2065 JAG Director of Sales, cell

**800-815-2557 • [www.jagmobilesolutions.com](http://www.jagmobilesolutions.com)**

# We pay attention to the details.

- Fabricated to the best industry standards using the highest quality products available
- Custom configurations to your specifications
- VISA, American Express, MasterCard, & Discover
- Fast, same day shipping, low freight rates



**ATLANTA  
RUBBER &  
HYDRAULICS**

1640 D Sands Place, Marietta, GA 30067  
Toll Free: 800.282.6272 • Phone: 770.955.5225  
Fax: 770.955.2377 • e-mail: sales@atlantarubber.com

Call Atlanta Rubber  
at  
**678.385.9645**  
for  
**2009 catalog**  
on  
hoses and fittings.



## Aqua-Zyme Disposal Systems

*"From the Grease Trap to the Garden"  
- Dewatering & Composting -*

**#1 Box on the market!**

### The ADS Dewatering System

is built by a pumping company for pumpers. You are welcome to come and watch the 30 yard box dewater 20,000 gallons of grease trap waste and/or septic tank waste in only 2 hours!

By using the ADS dewatering system along with our Compost Facility, we have turned our disposal costs into a profitable venture!

**Call 979-245-5656 for Info!**  
*\$ Financing Available \$*

P.O. Box 489, Van Vleck, TX 77482 • www.aqua-zyme.com  
1-979-245-5656 • zymme@aqua-zyme.com • U.S. Patent # 6,364,122



# Up to \$5,000 off all 2008 inventory.\*

NEW AND PRE-OWNED SALES | RENTAL | LEASING | PARTS | SERVICE | BODY SHOP | FINANCING

If you're in the market for a refuse vehicle, make Rush Refuse Systems your resource. We have one of the largest inventories of work ready trucks in the country, representing the industry's leading brands. Whether you need to buy, rent or lease, we have a full spectrum of financial resources available. And, we support you through our Rush Truck Centers network of over 50 locations — with an extensive parts and accessories inventory, highly skilled ASE-certified service professionals and exceptional body shop capabilities.

**THANK YOU FOR VISITING US AT THE 2009 PUMPER SHOW.  
SHOW SPECIALS WILL BE IN EFFECT UNTIL TRUCKS ARE GONE.**



## Peterbilt 340 Standard Vacuum Trucks

Automatics and standards in stock ready to go to work. Non-code 3600 gallon Pik-Rite tank. Masport HXL400WV liquid cooled pump, aluminum hose trays, internal primary to secondary piping for clean mount. 10 yr tank warranty standard. Options can be added before delivery. Compare our standard specs to anybody!



## Peterbilt 340 Industrial Vacuum Trucks

Automatics and standards in stock ready for delivery. DOT 407/412 3150 gallon Cusco units. Moro PM100 pump, hydraulic full opening rear, vibrator box, air actuated valves, full walkway with handrail. 20 ton dump capacity cylinder.



## 2008 and 2009 Peterbilt Cab and Chassis

Whether you're putting an old tank on a new truck, or custom building a truck the way you've always wanted, call us and choose from a wide variety of models and specs on the ground. Fast shipping available to your destination. Tank dealers and manufacturers welcome.



## 2009 Peterbilt 340 with 4000 Gallon Aluminum Vacuum Tank

Automatic or standard in stock ready to go to work. Imperial 4000 gal aluminum tank. Masport HXL400WV liquid cooled pump, Aluminum hose trays. Options can be added before delivery. Loaded out trucks! Two Stage engine brakes included.

# 877-661-4511

**Refuse Sales Team:** Gregg Wilkinson | Jason Guzauskas | Jesse Fullilove | Ryan Johle  
refusesales@rush-enterprises.com | 8810 IH-10 East | San Antonio, TX 78219

\*Prices listed here include discount and FET, and are subject to any state and local taxes. Discounts vary based on list price and age of vehicle. Prices subject to change. See your Rush Refuse Systems representative for complete details.

# Refuse Systems



www.rushrefusesystems.com



# Cash Flow is King

**Especially in the cyclical business of portable sanitation, a healthy financial reserve or a solid line of credit will cover expenses and keep the warehouse stocked**

*John Camphouse is chief financial officer for PolyJohn Enterprises, Whiting, Ind. Reach him by e-mail at john.camphouse@polyjohn.com*



**By John Camphouse**

**A**ccording to the U.S. Small Business Administration, most businesses that fail do so for lack of money management, not as you might expect from lack of sales or profits.

This is particularly true in the portable sanitation business, because the cost to service increases quickly during the busy months and payment for service can trail a month or two behind delivery of that service. Peak earnings come in summer, peak receivables come in early fall, and peak cash expenditures come nine months later.

Having enough money to manage cash flow on a day-to-day basis and making projections for the months and years ahead is a tricky job. If your cash reserves don't last or your line of credit isn't large enough, you won't be able to purchase supplies you need to make your busy season a success. You have to be able to generate the cash to cover the overhead as well as any new debt service payments.

## COVET PAYING CUSTOMERS

Even if you make the sale, you could fail if you don't charge enough to keep the business healthy for the entire 12-month business cycle. Along with underbidding jobs, another common mistake for startups is to pick the "low-hanging fruit" when you sign up new customers.

These are customers who need service because they have been dropped by a competitor, such as contractors who can't get service because they have had trouble in the past paying their bills. You make the sale, perform the service, but can't collect payment on time. This stresses your cash flow position and could lead to problems paying your debt, making payroll, or buying supplies such as fuel or consumables that allow you to continue servicing.

Sound pricing strategies are fundamental, and so is becoming aware of the credit history of new customers.

An annual budget is also vital to anticipating large recurring expenses, such as taxes, equipment renewal and seasonal employees. Developing a five-year spending plan for growth can show roughly how much needs to be saved each year, depending on how much growth you plan to achieve.

If you don't have enough capital to run your business through a complete season, then you may be interested in finding financing from a bank that supplies small business loans. There are two important factors involved in getting a business loan. The first is a proven track record (normally two years) with a healthy cash flow. The second is an excellent presentation of a sound business plan.

## LINE OF CREDIT

A lot of people use personal savings or borrow from relatives and start off small in order to develop a track record. However, someone who has a proven track record in another business and writes a sound and plausible business plan may be able to find startup capital with a financial institution.

An individual or partnership with little experience is normally advised to seek help from the SBA, which can guarantee up to 75 percent of the loan amount, making banks more comfortable about lending.

Ben Franklin's famous quote, "Neither borrower nor lender be," may have been good advice 200 years ago; but today your decision should be based on accounting principles and an understanding of cash flow.

How much you can borrow depends greatly on the true cash equity your business has. Banks look at debt-to-worth ratio to define the net worth. If you are a sole proprietor, they also look at your own net worth including home value, cars and other investments. But solid numbers alone won't win loan approval.

Presentation skills and your business plan are critical to a successful outcome. You need to present a business plan that includes a company background, purpose of the loan, product/market information and financial information.

Include projections on how you intend to accomplish your goals in your business plan. Explain the size and scope of the market, what the service entails, how much service costs you, how much you can charge, and where the capital to finance a purchase or lease equipment and to operate will come from.

Your confidence in the plan, knowledge of your business, and ability to answer bankers' questions appropriately may mean the difference between a large line of credit or no credit at all.

Whenever you create a business plan, be sure that projections are not overly "rosy." A good contingency plan will help you anticipate problems and have enough capital left to deal with them. Something unexpected always happens, and successful businesses have enough capital to deal with problems that lurk around the bend.

## LEASE OR BUY?

Ben Franklin's famous quote, "Neither borrower nor lender be," may have been good advice 200 years ago; but today your decision should be based on accounting principles and an understanding of cash flow, rather than the advice of others. The question of whether you should lease or buy equipment depends on how you plan to run your business.

If you expect your business to remain steady or if you have concerns about the economy, buying necessary equipment may make more sense than leasing it. The last thing a business owner wants during a downturn is to make lease payments on equipment that is not being used. However, if you own the equipment, it will be there when demand picks up.

If there is potential for growth for your business in the near term, leasing may be a good alternative to buying. As an example, if you use all your available cash to buy equipment and then find new customers, you have no way to buy additional equipment because your cash is already tied up. Leasing can be a way to keep more working capital on hand.

According to Mitch Davis of Preferred Lease, who specializes in leasing equipment to the portable sanitation industry, it takes about 20 percent of restroom units in service to make the monthly payments on leased equipment. "If you lease 100 units and rent 60, then 20 units are paying the lease on the entire 100, while the other 40 restrooms are bringing in cash that can be used for operating expenses and growth," he explains. ■

# LOADED PETES OR INTERNATIONALS YOUR CHOICE



## 2010 Peterbilt 340

**\$109,900.00**

US Funds – FOB Buffalo, NY  
*Many options available. Detailed specifications on request.*

- Cummins Paccar PX-8 330 Hp
- Fuller 10 speed
- 18,000 front axle, 40,000 pound rear axle
- Air ride, factory air-conditioning
- Chrome bumper
- Polished aluminum rims all around
- Bridgestone tires
- Full-locking differential
- Power windows



## 2010 International 7500

**\$102,900.00**

US Funds – FOB Buffalo, NY  
*Many options available. Detailed specifications on request.*

- International Maxxforce 10 350 Hp
- Fuller 10-speed transmission
- 18,000 pound front axle, 40,000 lbs rear axle
- Air-ride suspension, factory air-conditioning
- Combination engine/exhaust brake
- Polished aluminum rims all around
- Continental tires
- Thermostatically controlled heated mirrors

### **BOTH TRUCKS HAVE THE FOLLOWING OPTIONS:**

- 3600 gallon capacity
- 396 cfm fan-cooled TSI 500 vacuum pump
- 2 baffles
- 20" top man-way, 20" rear man-way
- Heavy-duty primary & secondary shut offs
- Toolbox

- Sight glasses
- Heavy-duty rear bumper
- Full-length hose trays
- 6" discharge, 4" intake
- Complete factory specs available upon request

WE PAY BORDER CROSSING CHARGES • LEASING? WE CAN REFER YOU TO THE SPECIALISTS • OVER 40 YEARS IN BUSINESS

**TRANSWAY**  
SYSTEMS INC.  
PROFESSIONAL VACUUM EQUIPMENT

[www.transwaysystems.com](http://www.transwaysystems.com)

**Toll-Free 800-263-4508**

**Tel. (905) 578-1000**

**Fax (905) 561-9176**

DELIVERY SERVICE  
AVAILABLE

314 Lake Ave. North  
Hamilton, Ontario L8E 3A2

# KMH EQUIPMENT COMPANY

SALES • RENTALS • SERVICE

Indianapolis, Indiana  
Marietta, Ohio

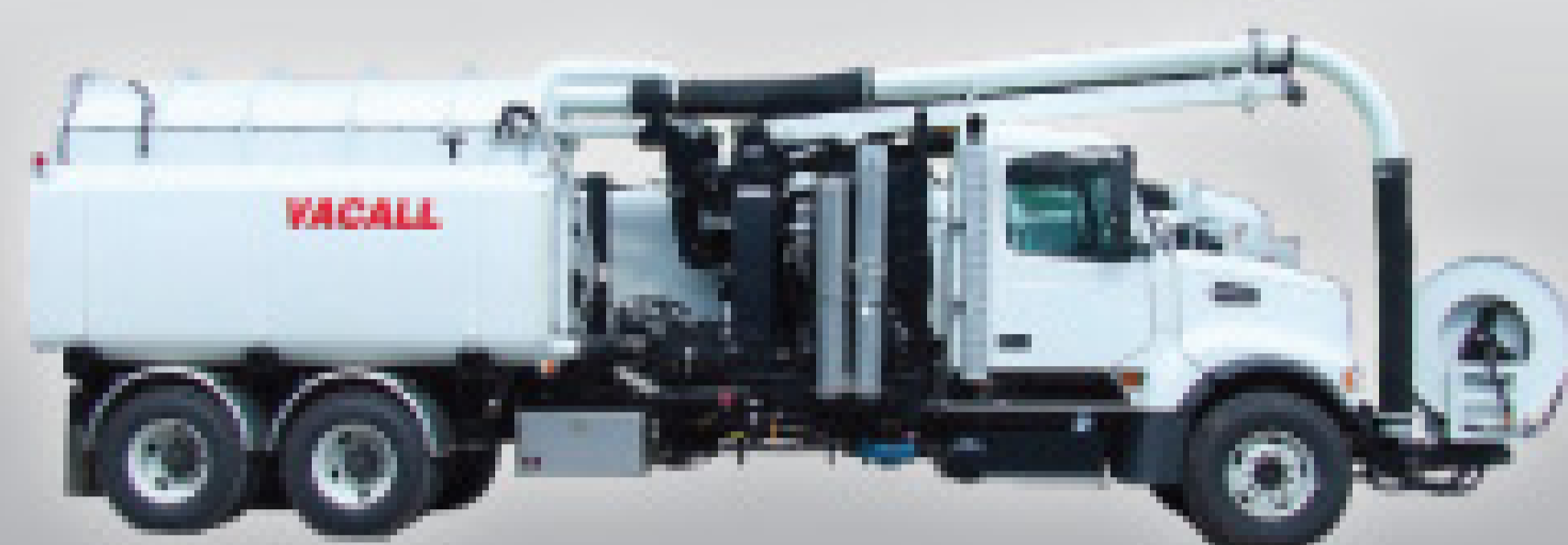

**VacAll AllJetVac**  
\$225,000\*



**Presvac DOT 407/412**  
\$165,000\*



**VacAll AllVac AVR B**  
\$235,000\*

AVAILABLE FOR SALE, RENT OR LEASE/PURCHASE

\*FOB Marietta, OH

1-888-564-0202

www.kmhequip.com

## Flagg-Air Model 340

- 3450 rpm
- 1/4 hp, 115V
- Enclosed motor
- Stainless steel shaft
- High impact plastic parts
- Operates quietly
- 2-yr. warranty
- Fits in place of most original manufacturers' units
- Replacement parts available



The Flagg-Air 340 does not carry the NSF seal. Check local and state regulations for approval in your area.

## MEDO HEM LA-80 Linear Pump



with low pressure alarm & light; with on & off switch

## MEDO Piston



LA-60  
LA-80B  
LA-100  
LA-120

## SECOH Diaphragm



EL 60  
EL 80  
EL 100  
EL 120



0523  
1023  
Rotary Vane Compressor

## Regenair®

R3105-12  
Blower

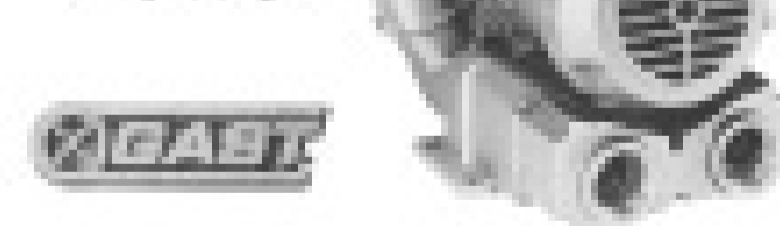

Hydromatic, Zoeller, ABS, Liberty & Myers Pumps

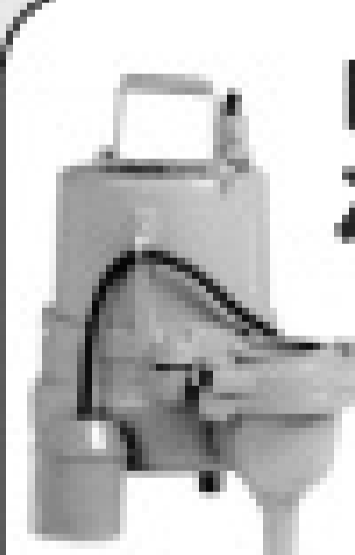

## Conde SDS 6 Engine Driven



Units available 20 to 180 cfm



**Moro PM80 Turbo 350 cfm**  
Moro Pumps: from 175 to 1642 cfm

## LIBERTY PUMPS

We Carry a Full Line of  
**LIBERTY PUMPS**  
and  
Pre-Assembled Lift Station Packages



Omnivore LSG 200 Residential Grinder



280-Series Mid-Range Effluent Pump



**BIO Control Panel**  
with Lift Station, Aerator, Timer & High Water Alarm

**Myers High Head Filtered Effluent Pump**



**Septic Services, Inc.**



toll free 1.800.536.5564 • 636.583.5564 • fax 636.583.6432  
e-mail septic@fidnet.com • web www.septicserv.com





Our **VALUE** goes deeper than you realize.

When it comes to portable sanitation solutions, WALEX delivers much more than blue deodorizers and accessories. We're giving you **innovative research & development** that has set all the current standards for excellence. You're getting **proprietary breakthroughs** that our competitors can only emulate. When you choose WALEX, you're not only getting **the best on the market today** — *you're also supporting your industry's future.*



For more information, contact us at **910.371.2242**, toll-free **800.338.3155**  
or visit our website at **[www.walex.com](http://www.walex.com)**.



Sludge Mate  
& Poly-Mate

The Flo Trend® Sludge Mate® and Poly-Mate® form an economical and simple to use sludge dewatering system. The Poly-Mate® conditions sludge through the addition of polymer prior to the dewatering process which occurs in the Sludge Mate®. These units are designed to dewater sludge from a multitude of waste stream sources including: water and wastewater treatment plants, septic tanks, car washes, industrial sumps and lagoons, grease traps, rendering plants, and food processing plants. The Sludge Mate® and Poly-Mate® are available in a variety of sizes and configurations, and are built to custom specifications.



**DEWATERING MADE SIMPLE.**

Flo Trend Systems Tel - 713-699-0152  
707 Lehman St. 800-762-9893  
Houston, TX 77018 Fax - 713-699-8054  
sales@fлотrend.com

**ALPHA**  
Mobile Solutions

Restroom & Shower Trailers

**\$90 DOWN**  
**\$90 per MONTH**  
**for 90 DAYS\***

www.alphamobilesolutions.com (877) 789-1213

\*With Qualified Credit/Ask About Details

**ERICKSON**  
TANK & PUMP

SEPTIC SERVICE TRUCK

PORTABLE TOILET PUMPERS

WASTE COOKING OIL PUMPER

Check Our Web Site for Current Inventory!

**"Tanks" for your business!**

VISA MasterCard **509.785.2955**  
WWW.ERICKSONTANK.COM

# SAVE TIME, MONEY... AND YOUR REPUTATION!

## **GAMAJET**®

- **Hands-Free Cleaning**
- **Eliminates Odors**
- **No Splash Back**
- **Cleans Entire Unit**
- **Satisfaction Guaranteed**

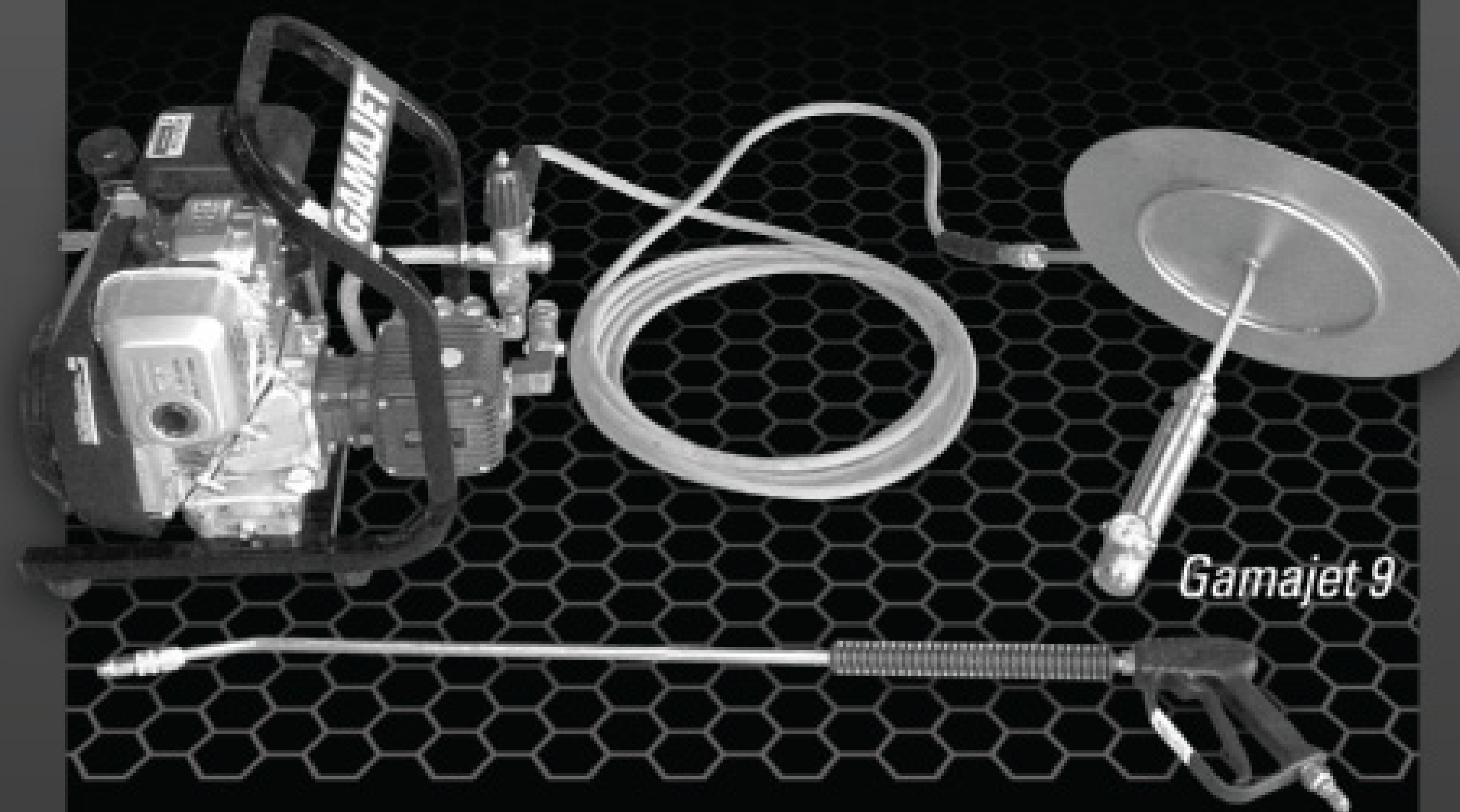

**LEASE OPTIONS NOW AVAILABLE!**

**Call 1-800-874-4747 for Pre-Approval!**

Gamajet Cleaning Systems, Inc. • 604 Jeffers Circle • Exton, Pennsylvania 19341

## **877-GAMAJET**

# Lighten My Load

## Posters reassure a pumper about his company's switch to aluminum vacuum tanks

*This feature in Pumper reports noteworthy conversations that take place in Pumper Discussion, an e-mail based forum for industry professionals sponsored by COLE Publishing. Pumper Discussion provides for the exchange of information and ideas on septic and drainfield installation and maintenance, trucks and equipment, portable sanitation, chemicals and additives, and much more. To find out more about Pumper Discussion, or to subscribe, visit [www.pumper.com](http://www.pumper.com).*

*Information and advice in Overheard Online is offered in good faith by industry professionals. However, readers should consult in depth with appropriate industry sources before applying such advice to a specific business situation.*

## Overheard Online

### HOW ABOUT ALUMINUM VACUUM TANKS?

#### Question:

My company is switching to aluminum tanks from steel, but I am a bit worried about the life of the tank. Do they coat the inside of the tank? Do aluminum tanks last longer than steel tanks? Has anyone's aluminum tank cracked or breached?

#### Answers:

I've had an aluminum tank for five years. Keep the truck on pavement and you will have good service from aluminum tanks. Go off the road or in the field where the tank would be subjected to binding and there could be problems. Also, beware of acids from caustic cleaners, like those used to clean range hoods in restaurants.



I have a four-year-old aluminum tank and have no complaints. Remember to mount the tanks on an air-ride truck only. My tank has a sump pit at the discharge end. That helps keep grit from building up inside the tank. My other truck only has a 6-inch discharge pipe weld-

I ran steel tanks for my first seven years in business. I grew to the point of needing to carry more weight, but didn't want to get a bigger truck that would require me to have a CDL. Naturally, with aluminum, you are able to carry the most waste. I've used aluminum tanks since 1999 without any problems.

ed in the bottom of the tank and I have been inside the tank four times in one year to clean the grit out.



I ran steel tanks for my first seven years in business. I grew to the point of needing to carry more weight, but didn't want to get a bigger truck that would require me to have a CDL. Naturally, with aluminum, you are able to carry the most waste. I've used aluminum tanks since 1999 without any problems.

Last year I was on a two-lane road and there was a pickup truck pulling a hay wagon ... darted left across the lane in front of me. I was headed straight for his door and close enough to see his eyes. I veered left instead of hitting him in his door. I went through the ditch to the left then came up onto the side road, where I hit him with a glancing blow.

I then went through another ditch and into a cornfield, where I rolled the truck over. Everyone walked away that day. The truck had \$48,000 in damage, but the tank with 1,000 gallons of muddy water in it survived without even a crack in any of its welds ... The insurance company had the tank tested, and if it would have had any damage, the truck would have been totaled.

### WHAT ABOUT DAMAGE WAIVER FEES?

#### Question:

We are thinking of charging customers a monthly damage waiver fee for portable restrooms if they don't sign and return the customer service agreements. Have any of you ever done this? Do you have any suggestions?

#### Answer:

I looked into customer agreements and service charges a while back and determined the expense of the paperwork versus the actual amount of damage we receive in a year did not make it worthwhile for me. Another thing I noticed was the better the service I provided and the cleaner I kept the toilets, the less damage I got.

At the end of the day it is better to have the customer than lose them over an extra charge. But go with your gut, and if you think they will damage your toilet no matter what, maybe it isn't worth your time.

## NEED SOFTWARE?



The Leading QuickBooks® add-on Software for today's Portable Sanitation Business.

- Software now starting from \$49.95 per month. PC based.
- Interface with QuickBooks® -The Service Program generates your recurring route billing and seamlessly allows you to print the invoices in QuickBooks®
- Easily Manage Routes
- Palm and Windows PDA Handheld Support w/Remote Sync
- Track Pick-Ups & Drop-Offs
- Works with Mapquest® and Mappoint®
- Track Inventory at Multiple Locations
- 30-Day Money Back Guarantee-Leasing Available
- 30 Day No Risk FREE Trial with Weekly Training
- FREE Updates

**866.480.1879**  
[www.theserviceprogram.com](http://www.theserviceprogram.com)



### NEW! WATERBLAST HOSE



	PSI	10k	14k	16k	18k	21k
1/2" x 50'		\$240		\$261		\$438
3/8" x 50'		\$235			\$259	
3/4" x 50'			\$364			
1" x 50'		\$450				



### BUY BULK AND SAVE!

EPDM SUCTION BULK  
100 FT ROLLS



### EPDM SUCTION CPLD M X F QUICK CONNECT



3" X 20'	<del>\$84.95</del>	<b>\$79.95</b>
3" X 25'	<del>\$101.95</del>	<b>\$94.95</b>
3" X 30'	<del>\$117.95</del>	<b>\$109.95</b>
3" X 33'	<del>\$129.95</del>	<b>\$118.95</b>

### NEW PORTABLE TOILET HOSE!

PORTA-TUFF HOSE



*A Varco Exclusive!*

2" X 25'	<b>\$91.70</b>
2" X 30'	<b>\$108.70</b>
2" X 35'	<b>\$125.45</b>
2" X 40'	<b>\$142.20</b>

- NO CUFFS!
- 100 FT LGTHS
- EASY REPAIR!
- MOST FLEXIBLE HOSE WE HAVE!

### TIGER TAIL CPLD M X F QUICK CONNECT



2" X 25'	<del>\$96.75</del>	<b>\$91.70</b>
2" X 30'	<del>\$113.00</del>	<b>\$108.70</b>
2" X 35'	<del>\$129.75</del>	<b>\$125.45</b>
2" X 40'	<del>\$145.50</del>	<b>\$142.20</b>

## VALVES

### LEVER VALVES

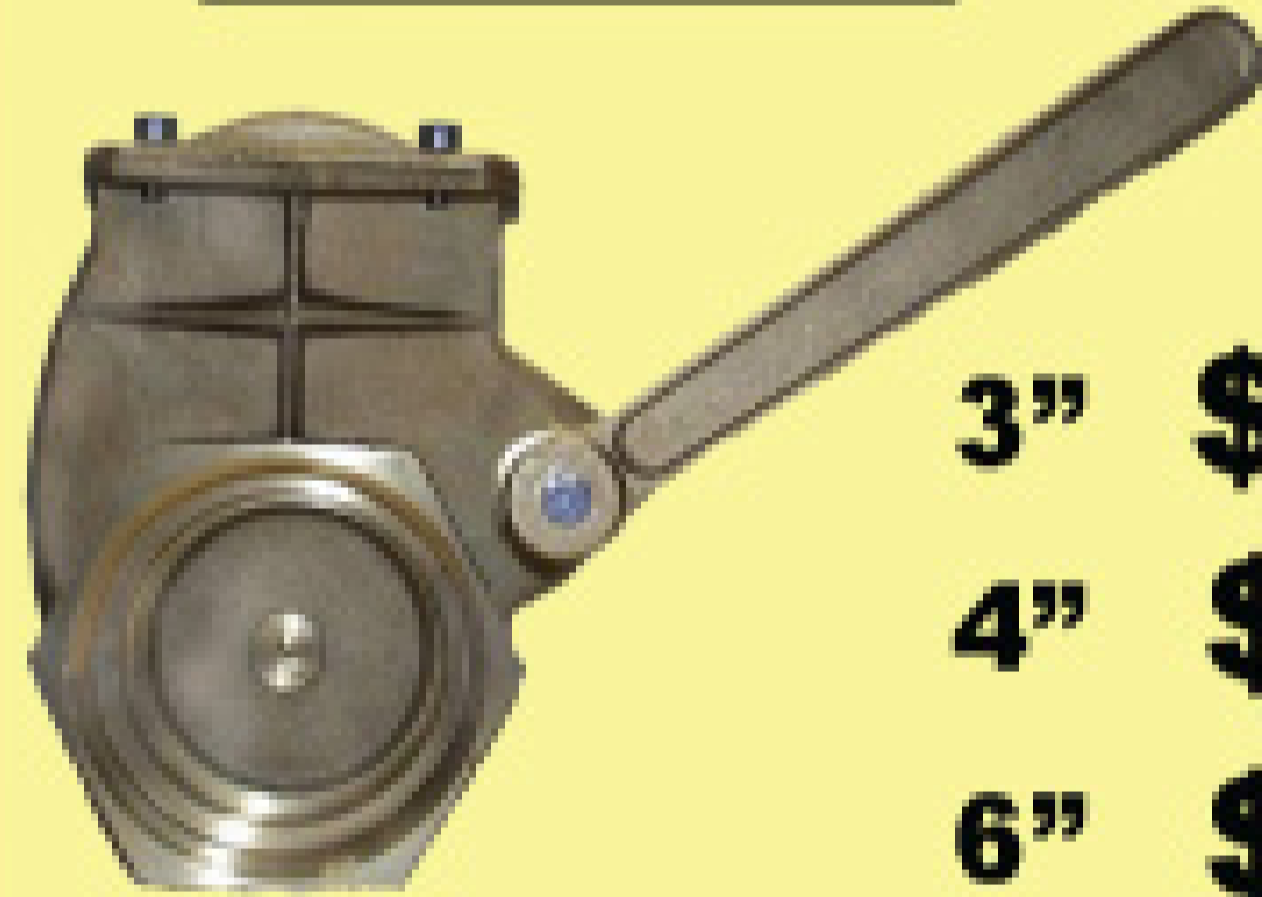

**CRAZY PRICE!**

3"	<b>\$105.95</b>
4"	<b>\$154.95</b>
6"	<b>\$268.95</b>

**NO ONE BEATS OUR PUMP PRICES!**

## PUMPS

### JUROP R260



- 383 CFM
- 18" CONTINUOUS DUTY
- BALLAST PORT COOLING
- AUTOMATIC OILER

**\$2695<sup>95</sup>**

### JUROP PN58



- 230 CFM
- FORCED OIL LUBRICATION
- 3" CON-NECT

**\$1580<sup>95</sup>**

### JUROP PN23



- 93 CFM
- FORCED OIL LUBRICATION
- 3" CON-NECT

**\$1140<sup>95</sup>**

### SAVE MONEY- PROTECT YOUR FITTINGS!

#### SAFETY LOCK

2"	<b>\$1.65</b>
3"	<b>\$1.95</b>
4"	<b>\$2.50</b>



#### SAFETY BUMPS

COMFORTABLE HANDLE  
SAFEGUARDS YOUR FITTINGS

2"	<b>\$16.25</b>	MXF SET
3"	<b>\$25.95</b>	MXF SET
4"	<b>\$33.75</b>	MXF SET

### COUPLINGS AND REDUCERS



**100'S OF THEM!**



### FEMALE X MALE REDUCER



3" X 2"	<b>\$17.85</b>
4" X 3"	<b>\$26.25</b>
6" X 4"	<b>\$45.95</b>

## VAC TRUCK ACCESSORIES

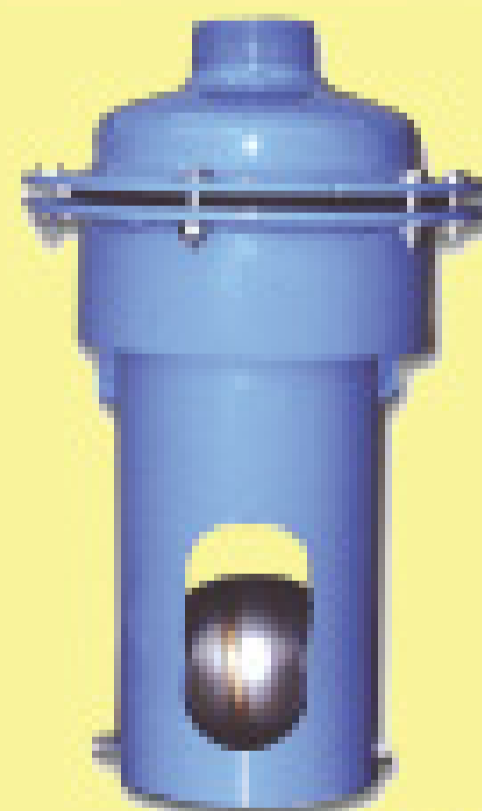

### 1 1/2" BRASS VACUUM RELIEF VALVE

2"	<b>\$173.25</b>
3"	<b>\$173.25</b>



**\$21.95**



### BRASS PRESSURE VALVE

**LOWER PRICE!**

1 1/4"	<b>\$24.95</b>
1 1/2"	<b>\$28.95</b>
2"	<b>\$36.95</b>



### VACUUM PRESSURE GAUGE

- 0-30 Vacuum
- 0-30 PSI
- Liquid Filled
- 1/4" Male NPT

2.5" Face	<b>\$13.95</b>
4" Face	<b>\$40.95</b>



2"	<b>\$157.95</b>
3"	<b>\$215.95</b>

### HOSE BREAKING OFF AT TRUCK? YOUR CHOICE SAME PRICE

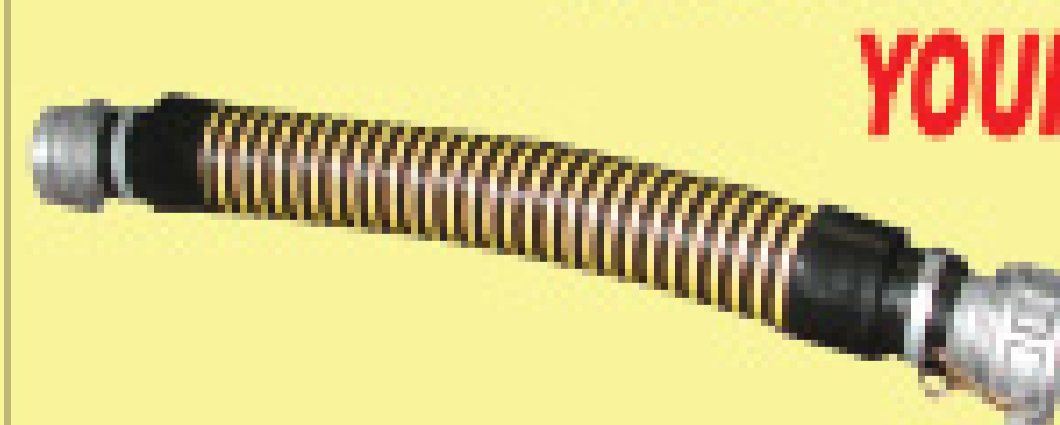

VARCO FLEXI-JOINT

**\$51<sup>99</sup>**



VARCO TUFF-JOINT

**\$65<sup>99</sup>**

### SLUDGE HOE



**\$62.50**

### SCRAPERS



from \$50.00

Includes Fiberglass Handle!  
from **\$105**

FREE CATALOG



SHOP ONLINE AT [WWW.VARCOPUMPER.COM](http://WWW.VARCOPUMPER.COM)

OPEN LATE NITES AND WEEKENDS!

TOLL FREE

**866-872-1224**

SOURCE KEY  
4P9



# Manufacturing

- *Stainless Steel*
- *Aluminum*
- *Code & Non-Code*



45 Years of Manufacturing Experience

Vacuum Trailers for the  
Liquid Transportation Industry

Parts • Repair • Complete Pumping Systems

# 800-589-5254

www.acrotrailer.com • 417.862.1758 • fax 417.862.8084 • 2320 North Packer Road • Springfield, Missouri 65803

## 1000 Gallon Trailer Mounted Vacuum System

## EXPERTS IN PORTABLE VACUUM SYSTEMS!



### PACS 1000

PACS trailer mounted vacuum systems are available in a variety of configurations. PACS 1000 is designed for removing liquids, solids, and sludge from land or water. Costing less than vacuum trucks, the PACS is approved for highway towing. Integral hydraulics allow the PACS to run oil skimmers and pumps, as well as lift the tank to dump contents.



**ELASTEC**  
All Terrain Vac

### Oil Skimmer

**Sucking up money for vacuum trucks**

Our Drum Skimmers are optimal for rapid response oil cleanup. Extremely efficient and cost effective, they will give you an edge over competitors.



### DrumIt

The drum filling vacuum head with auto shut off. DrumIt quickly connects to vacuum trucks for a clean interception of debris and liquids.



**ELASTEC**  
AmericanMarine  
Innovative Environmental Products

1309 West Main, Carmi IL 62821 USA  
Tel: (618) 382-2525  
Fax: (618) 382-3610  
E-mail: [elastec@elastec.com](mailto:elastec@elastec.com)



[www.elastec.com](http://www.elastec.com)

PU10/08

# Top Line

**Fuel pricing is back down...**

**The cost of plastic is back down...**

**TOP LINE PORTABLE TOILET PRICE  
IS BACK DOWN TOO!**



**Limited  
time  
offer!**

**ARMAL Inc.**

122 Hudson Industrial Drive - Griffin, GA 30224 - USA

Phone 770 491 6410 - Fax 770 491 9458

Toll free 866 873 7796 - [armal-inc@armal.biz](mailto:armal-inc@armal.biz)

**Armal<sup>®</sup>**  
[www.armal.biz/usa](http://www.armal.biz/usa)

# No COMPROMISE



**Don't accept a substitute for quality. The Burks DC-10 is still the most popular, high volume washdown pump available.**

*With flow rates to 20 gpm and pressure to 40 psig, the Burks DC-10 is the pump of choice for filling and washing your portables.*

*Contact your local tank manufacturer for more info, or call us toll-free at:*

**800-699-7557**

**ARMSTRONG  
EQUIPMENT  
INC.**

11200 Greenstone Ave. • Santa Fe Springs, CA 90670  
562-944-0404 • Fax: 562-944-3636

[www.vacpump.com](http://www.vacpump.com)

SINCE 1937

## GLENDALE WELDING CO.

6725 N.57TH DRIVE GLENDALE, ARIZONA 85301

### PORTABLE TOILET TRUCKS



#### WE DO IT ALL:

- REFURBISH YOUR OLDER TRUCKS
- REPAIR PUMP AND SYSTEM PROBLEMS
- CUSTOM PAINT
- PUMPER 101, THE BOOK, WITH EVERY ORDER OVER \$100.

WE ARE THE HOME OF THE VACUUM TRUCK INDUSTRY.

### SEPTIC PUMPERS

STAINLESS STEEL  
ALUMINUM  
CARBRON STEEL

BUILDING VACUUM TRUCKS REQUIRES THE BEST IN EXPERTISE, EXPERIENCE AND QUALITY. TO MEET THOSE REQUIREMENTS, WE BRING OUR 'A' GAME TO EVERY TRUCK AND TO EVERY CUSTOMER

[www.glendalewelding.com](http://www.glendalewelding.com)



623-937-7414



# WHAT'S THE DIFFERENCE BETWEEN A BULLET AND A SLUG?



## **DriPax, THROW AND GO DEODORIZER. IT'S ALL ACTION!**

Those bullets streaking down the highway can be your trucks when you use new DriPax throw and go deodorizer. No more messy liquids, no more awkward measurements, no half dissolved tablets and packets, no delays. Just pure deodorizing power in a 100% biodegradable portion controlled pack. DriPax is all action - no fillers. It's the difference between a bullet and a slug.

**Aim to get your free samples now. Call (800) 241-7951.**



**POLYPORTABLES**

*Listening. Learning. Delivering. Since 1972*

99 Crafton Drive, Dahlonega, GA 30533 USA • Phone (800) 241-7951 or (706) 864-3776 • Fax (706) 864-8111 • [www.polyportables.com](http://www.polyportables.com)

Only PolyPortables offers high-performance Green Way Products

**TOILET DEODORIZERS • TOILET CLEANERS • AIR FRESHENERS • INSECT REPELLANT**

All Green Way deodorizers, cleaners and air fresheners are earth-friendly, people-friendly products. They are developed and manufactured in our facilities in Dahlonega, Georgia by Green Way Products, a PolyPortables sister company.

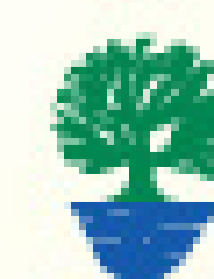

**Green Way Products**  
solutions for life

# Bullish on Portable Sanitation

Despite an economic slowdown, some contractors look to bolster their restroom inventories

By Mary Shafer

If my conversations with pumpers are any indication, there's a movement afoot to either diversify into portable restroom rental, or to enlarge their presence in that market if they're already there. A few contractors tell us here what's happening with the portable sanitation side of their businesses.



**Name:**  
**Bobbie Reppa,**  
**co-owner**  
**Company:**  
**Macy's Services**  
**Location:**  
**Jackson Hole, Wyo.**  
**Employees: 12**  
**Years in**  
**Business: 29**

Bobbie Reppa and her husband, Dwight Reppa, have owned Macy's Services since 1999, but the business has been in the family for 20 years. The company specializes in septic tank pumping and inspections, drainfield restoration, sewer jet service and video line inspection. They also have a healthy portable sanitation business in

the tourist-oriented ski town of Jackson Hole. Restroom rental accounts for 40-50 percent of their annual billings.

Jackson Hole is famous for its challenging, well-groomed ski slopes. Along with luring the usual tourist traffic, the area is a vacation home to many celebrities and business executives. That makes it "a community with a lot of money," Bobbie Reppa says. "There's so much second home building and golf course building going on," that the construction bubble hasn't burst there yet.

"You'd think they'd run out of land, but they just keep finding little corners to build. And at Teton Village — the ski area — they're putting in a lot of very high-end hotels, very big ones." To serve all the building contractors, Macy's has about 400 Satellite Industries Tufway and PolyJohn Enterprises Corp. PJ3 units. Currently, 90 percent of their portables business is with contractors.

Then there are the special events. "We serve a lot of weddings," Reppa says. "There's a big wine auction in the summertime, a fundraiser. We use the restroom trailers for that one." Macy's has a large ACSI Inc. restroom trailer, a mid-size unit from JAG Mobile Solutions, and a two-station unit from an independent company in Salt Lake City, Utah. "There's also the Snow King Hill Climb," the largest snowmobile event of its kind in America, according to Reppa. "It takes a lot of units, attracting 15,000 to 20,000 people a day, easily.

## Pipelines Plus:

Historical re-enactments are becoming popular family-style entertainment as more people become curious about their roots. They're also getting to be big business for all sorts of vendors, including those offering portable sanitation. If you're prospecting for new customers and think you might be interested in finding out what kind of historical re-enactment events are offered in your area, here are a couple sources to check out:

- Listings from a member of the Society for Creative Anachronism, the world's largest organization of Renaissance and medieval re-enactment companies: [www.panix.com/~wllinden/enact.html](http://www.panix.com/~wllinden/enact.html).
- Reenactor.net, the Worldwide Home of Reenacting (Scroll down to the lower left of the navigation bar to their calendar, and choose the era that interests you.)

Comments may be directed to Mary Shafer in care of Pumper. You may also e-mail [pipelines@pumper.com](mailto:pipelines@pumper.com).

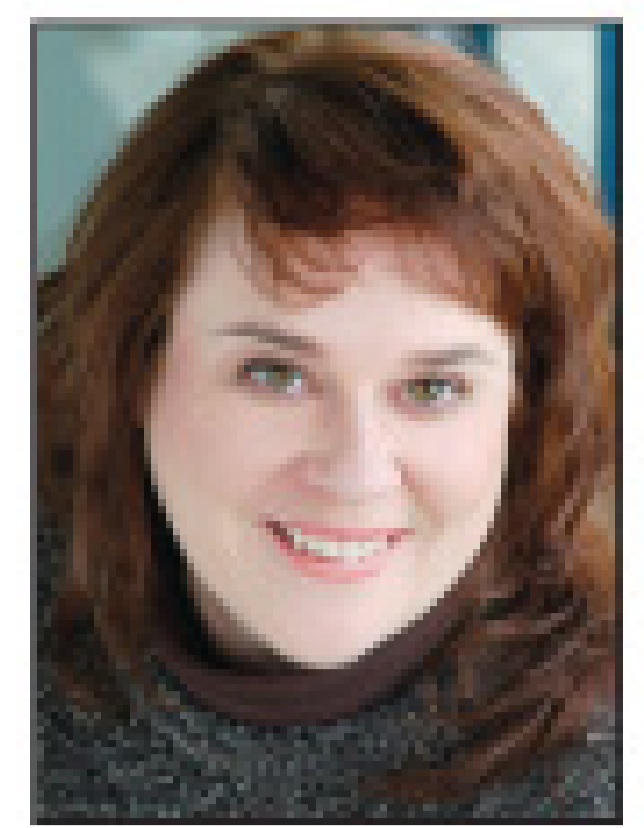

"We put out 60 to 90 units for that one." Macy's supplies Satellite Maxim 3000 units for events, including six ADA models.

Reppa anticipates that the portables side of Macy's will continue to grow, since she believes its specific market is mostly insulated from the kind of economy-slowng influences most of the country is currently subject to.

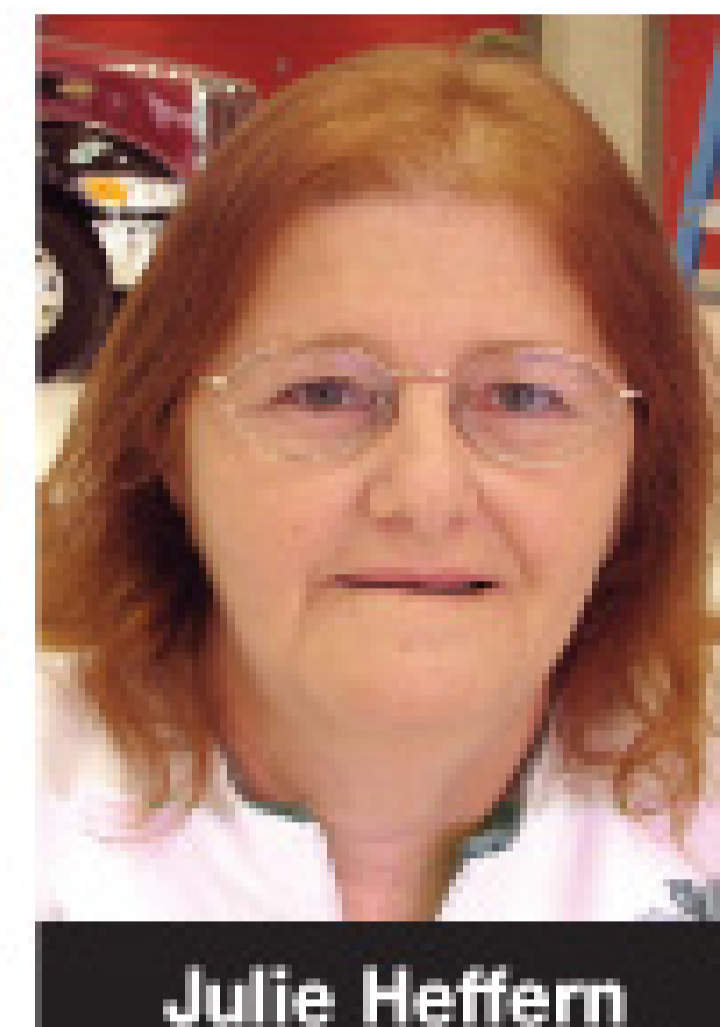

**Name:**  
**Julie Heffern**  
**Company:**  
**Heffern Septic Tank**  
**Service**  
**Location:**  
**Franklin, Pa.**  
**Employees: 6**  
**Years in**  
**Business: 40**

Julie and Chip Heffern took over the family septic-pumping business in 1979, started by Chip Heffern's father in the 1960s. Located 40 miles south of Erie, Heffern provides pumping, drain cleaning and portable restroom service to their region of northeast Pennsylvania. Julie Heffern says about half their business comes

from the portables side, and she anticipates the segment will continue to grow.

Currently, Heffern's rental ratio splits out at about 40 percent construction and 60 percent special events. Though Franklin's building boom has slowed, Heffern has noticed a growing demand for special events units. "Everybody's picking up on (portable restrooms) for reunions, outdoor picnics; all the ball fields have them now."

Despite the slowdown in building, Heffern believes construction unit demand will also increase. "With a lot of the laws changing on the contractors now, a lot of the smaller jobs that didn't have one will now be needing them. A lot of contractors are more apt to have a portable toilet on site now. Like the gas and oil well drillers, if they were way back off the road before, it wasn't necessary that they had to have one. But now they do with new environmental codes from the state."

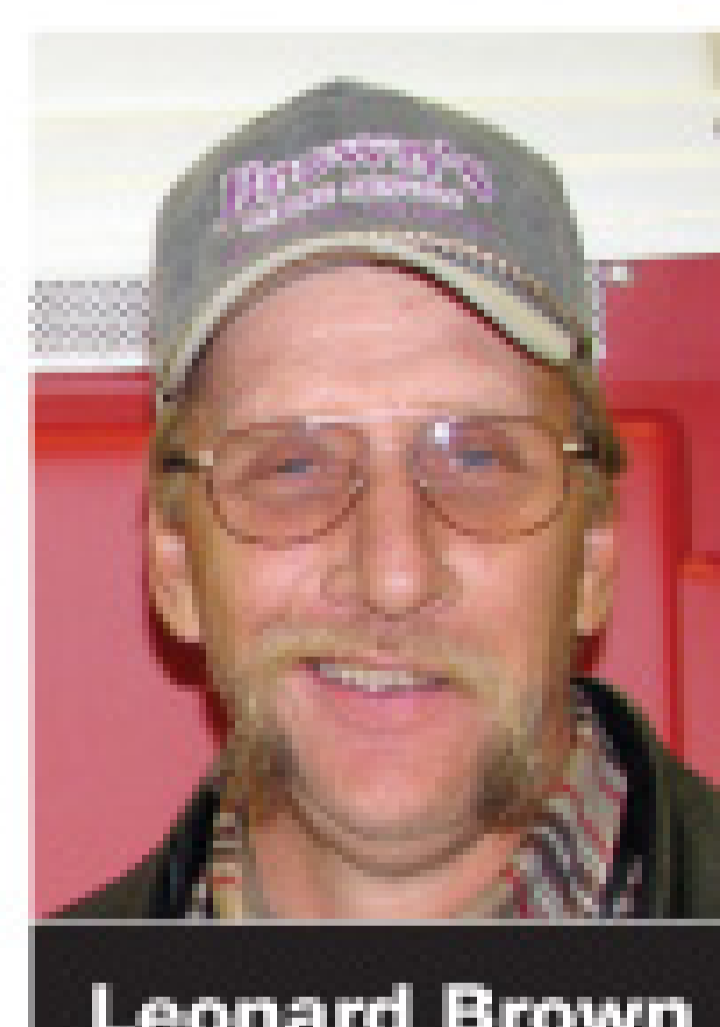

**Name:**  
**Cindi Brown and**  
**Leonard Brown**  
**Company:**  
**Brown's Septic**  
**Service Inc.**  
**Location:**  
**Del Norte, Colo.**  
**Employees: 4-5**  
**Years in**  
**Business: 13**

Cindi Brown and her husband, Leonard Brown, began their business as a septic pumping firm in Del Norte, Colo., about halfway between Colorado Springs and Durango in the southwestern part of the state. About 10 years ago, they got into portable restrooms as well, when they learned of the wide need for on-site sanitation by farmers in

the agricultural region. Workers needed restrooms so they wouldn't have to be transported back and forth from the fields. Such transport was a time and money waster for the farmers, as it interrupted productivity.

The Browns now field more than 180 Satellite Tufway units. About 150 of those serve agricultural customers, and the rest are reserved for events. "We don't have many events in our area," explains Cindi Brown. "Generally, we do a few weddings and the annual Mountain Man Rendezvous."

Portables account for half the company's annual billings, and Leonard Brown believes the demand for portables will continue to grow. They've already had enough demand for the trailer-mounted units they've built, and though the growth is slow, it remains steady. ■

# IN STOCK! Same Day DELIVERY!

## There Has Never Been A Better Selection Of 'ON-THE-LOT' Work-Ready Vacuum Service Trucks

# Drive A New Kenworth

Now for about the same price as a Chevrolet or Ford.



### 2008 Kenworth T3 Series / 1700 Gallon Aluminum Tank Aluminum Cab - Non CDL - 22,000 G.V.W.

8,000 lb front axle -14,000 lb rear axle  
Paccar (Cummins) Diesel, Turbo exhaust brake  
Allison auto transmission, 19" Wheels

*So much more...*

Power door locks, AM/FM, Cruise control,  
Air suspension seat, R.H. electric window  
Piano-style door hinges, Peeper window in door.

#### 1700 Gallon (400 water / 1300 waste)

Low style work station on drivers side, bucket holders,  
Masport HXL4 vacuum pump, remote controls, unit hauler  
Burks DC 10 wash down system with timer and bypass,  
spring rewind reel, large cabinets... *all the features.*

**BEST  
BUY!**



**\$73,975**

# L.C. TANKS

LaVerne Charlet

email: [lctanks@bellsouth.net](mailto:lctanks@bellsouth.net) fax: 270-898-4055  
175 Cascade Dr, Paducah, KY 42003

# 1-888-848-3727

### 4000 Gallon Steel Tank with Aluminum Trays

NVE 506 Max Pak, hydraulic drive, 500 CFM  
Del front hoist/rear open door system. **Vibrator.**

#### 2009 Peterbilt Model 340

18,000 lb. front 40,000 lb. rear, 330 H.P. Cummins,  
manual transmission. **Chrome Bumper.**

**\$132,729** Plus FET *monthly from \$2010*



### 2000 Gallon Septic Pumper

Masport HXL75 pumping system.

#### New! 2007 Chevrolet 7500 Series

Auto trans., air brakes, tool boxes

**\$73,329** *monthly from \$1466*



### 2000 Gallon Grease Pumper

NVE 367 Max Pax pumping system.  
(2) reels, base remote, heated tank, tool box

#### 2009 SterlingActera

Auto transmission, air brakes...loaded.

**\$93,430** *monthly from \$1868*



**IN STOCK! Work-Ready**  
Immediate Delivery

**Fast Delivery** On Custom Builds

**Lease Financing**

Guaranteed

Credit Approval



## The ALL New Comfort Elite

- Hydraulic Lowering System: no steps, platforms or railings
- 20' modular unit features 10 private unisex restrooms
- 4-sink exterior handwashing station
- Vacuum Macerator Pump System: allows for direct sewer connection, doubles usage capacity and low fresh water demand

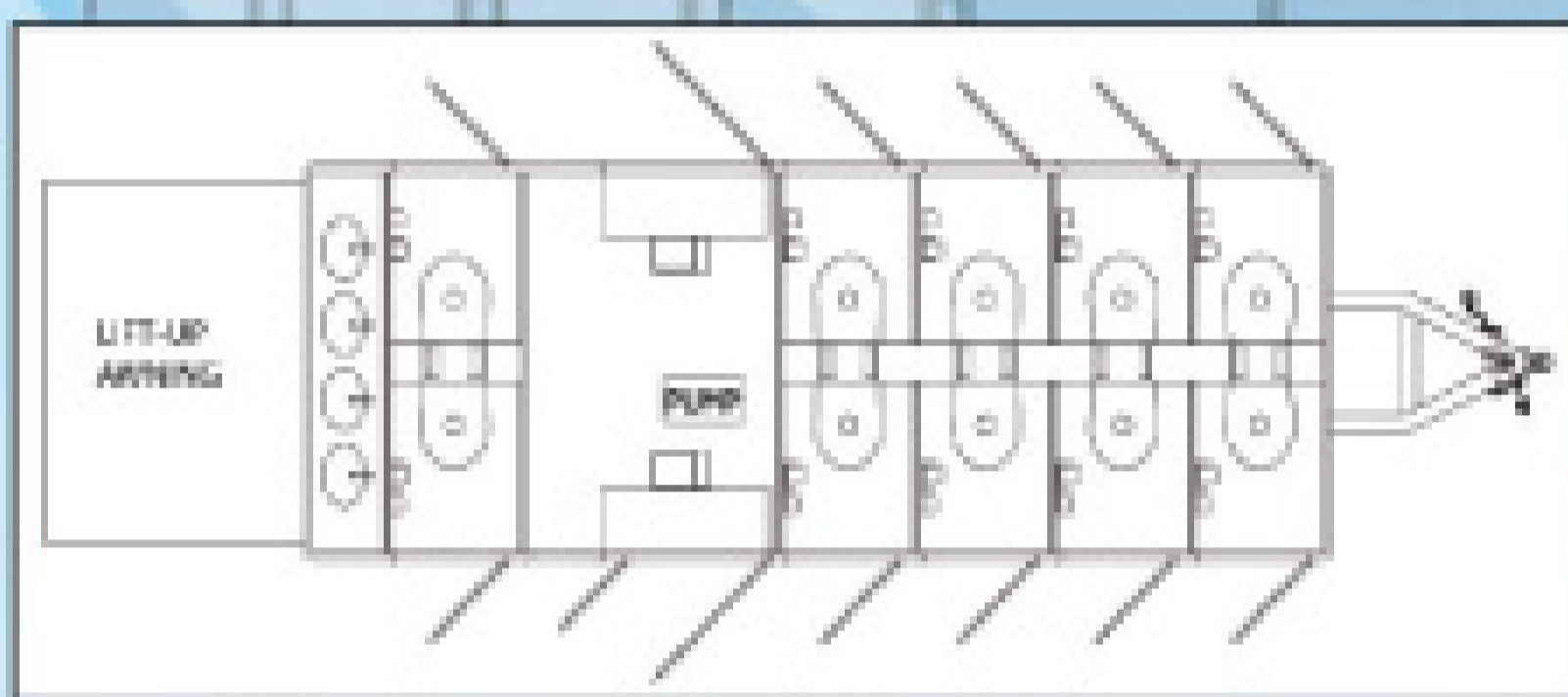

### Wells Cargo COG

Effective Solutions. Uncompromising Quality.

Phone: (888) 574-4222

Web: [www.wellscargoCOG.com](http://www.wellscargoCOG.com)



# Septic-Scrub™

## The First Choice for Pumpers to Restore and Maintain Drainfields

Backed By Science ■ Proven with Experience ■ Many Satisfied Homeowners

Septic-Scrub™ is a superior product for the maintenance and restoration of septic system drainfields. Customers appreciate that it is environmentally safe, contains no organic chemicals and does not produce any toxic by-products. Most importantly, **Septic-Scrub works.** It breaks down sulfide buildup in the biomat and soil to allow for better water absorption.

Learn more about Septic-Scrub at [www.arcn.com](http://www.arcn.com).

### arcn

P.O. Box 31057  
Clarksville, TN 37040

For information on increasing sales and providing a valuable service to your customers, call Arcan Enterprises at **888-35ARCAN (352-7226)**



Toll Free 888-207-2074

Fax (479) 770-6089

## WILCOX TRUCK SALES, INC.



Lowell, Arkansas

SINCE 1978

I-540 Exit #78 & Hwy 71B

2 hours East of Tulsa or 1.5 hours South of Joplin

[www.wilcoxtrucksales.com](http://www.wilcoxtrucksales.com)

## 1997 International Paystar 5000



**\$75,850**

M11 Cummins, 330 HP, 9 LL, Hendrickson, 4.89 Ratio, Budd Wheels, 208,766 Miles, 20/46 GVW, Quad Locks, New 100 Barrel, 4,200 Gallon Vacuum Tank, New Juroop R260 Pump

Also, **1998 IHC 4700** with New

Approx. 2500 Gallon Vac. Tank, with (2) 21" Domed Top Washout Manways, (1) 36" Domed Rear Cleanout, (2) 1/4"

Dished Baffles, New Juroop R260 Pump, DT466, Air Brakes, A/C

## 1987 International F9370

Big Cam Cummins, 350 HP, 9 Speed, Hendrickson Suspension, 236" WB, Budd Wheels, 70 Barrel Vacuum Tank, Gardner Denver Pump



**\$35,250**



# All In!

When you receive *Pumper* each month there is no need to bluff.

Join 25,000 of your industry peers each month who welcome *Pumper*, for the unlimited value it brings them. Each issue will show you new tools, tips to save on expenses, money-saving deals and much more.

**800.257.7222**  
**[www.pumper.com](http://www.pumper.com)**

Subscribe today  
to guarantee  
your winning  
hand!

# ***2009 V.E. Enterprises 'Raptor' Bobtail Tank***



## ***Why Choose A V.E. Enterprises Bobtail Tank?***

### ***Ten good reasons:***

- 1. Built by ASME certified welders***
- 2. All vertical welds are sub-arc welded providing 100% penetration***
- 3. ASTM SA-36 grade 1/4" steel barrel, heads and baffles***
- 4. Barrel padded with 1/4" plate at all contact points***
- 5. 4" channel ring supports on barrel for 90, 100 barrel models***
- 6. Wider hose troughs with standard rear hose hooks***
- 7. Wedge shaped sump or loading lines with 4" butterfly valves***
- 8. Trailers prepped with steel shot blast creating a 2.5 mil anchor profile***
- 9. Primed and painted with DuPont Imron for the ultimate in durability***
- 10. Built for and by our customers; call us for available options***

*\* Available in sizes from 60 to 100 barrels; turn-key installations available through VE authorized dealers*

***Setting the Standard For Liquid Storage and Transport Markets Since 1987.***

**800-234-2329**

**www.veenterprises.com**  
**sales@veenterprises.com**

10834 St. Highway 53 • P.O. Box 369 • Springer, OK 73458



**ENTERPRISES, INC.**



# TRI STATE TANK

...Setting New Standards in Truck Mounted Tanks!

**BUY IT NOW! \$99\***  
**'Guaranteed Credit Approval'**

1200 Gallon Septic Pumper  
 Masport HXL75 pumping system.  
 2008 Sterling Bullet 305 HP Cummins,  
 auto trans., hyd. brakes, 84" C.A.

**\$69,750**

As Low As **\$1243** mo.

2008 Kenworth T300 - 22,000 GVW  
 Cummins, Allison auto., Hyd. brakes, AC.  
 1700 Gallon 300 Fresh-1400 Waste  
 Masport HXL 4, Burks wash down,  
 Hot shift PTO w/remote.

**\$73,975** As Low As **\$1120\*\***mo.



**Front Lift- Rear Opening Door**  
**3800 Gallon Septic 'Painted Aluminum'**  
 Robuschi RB-DV65 pump - 912 CFM  
 2009 International 7500  
 350 H.P., 10 speed transmission  
**\$139,975** Plus \$8,316 F.E.T.



**Call Us At**  
**800-971-7657**  
 Fax: 913-281-9152

\*Per month until September 2009, thereafter regular payments for 60 months with no residual buyout.

\*\*Through PACCAR Financial



**sales@tristatetank.com**

**www.tristatetank.com**

## MEGA Holding Tank

1250 Gallon Size



### Options

Black Color • Level Alarm • Custom Fittings

## LOW PROFILE Portable Holding Tank

100 • 210 • 300  
 Gallon Sizes

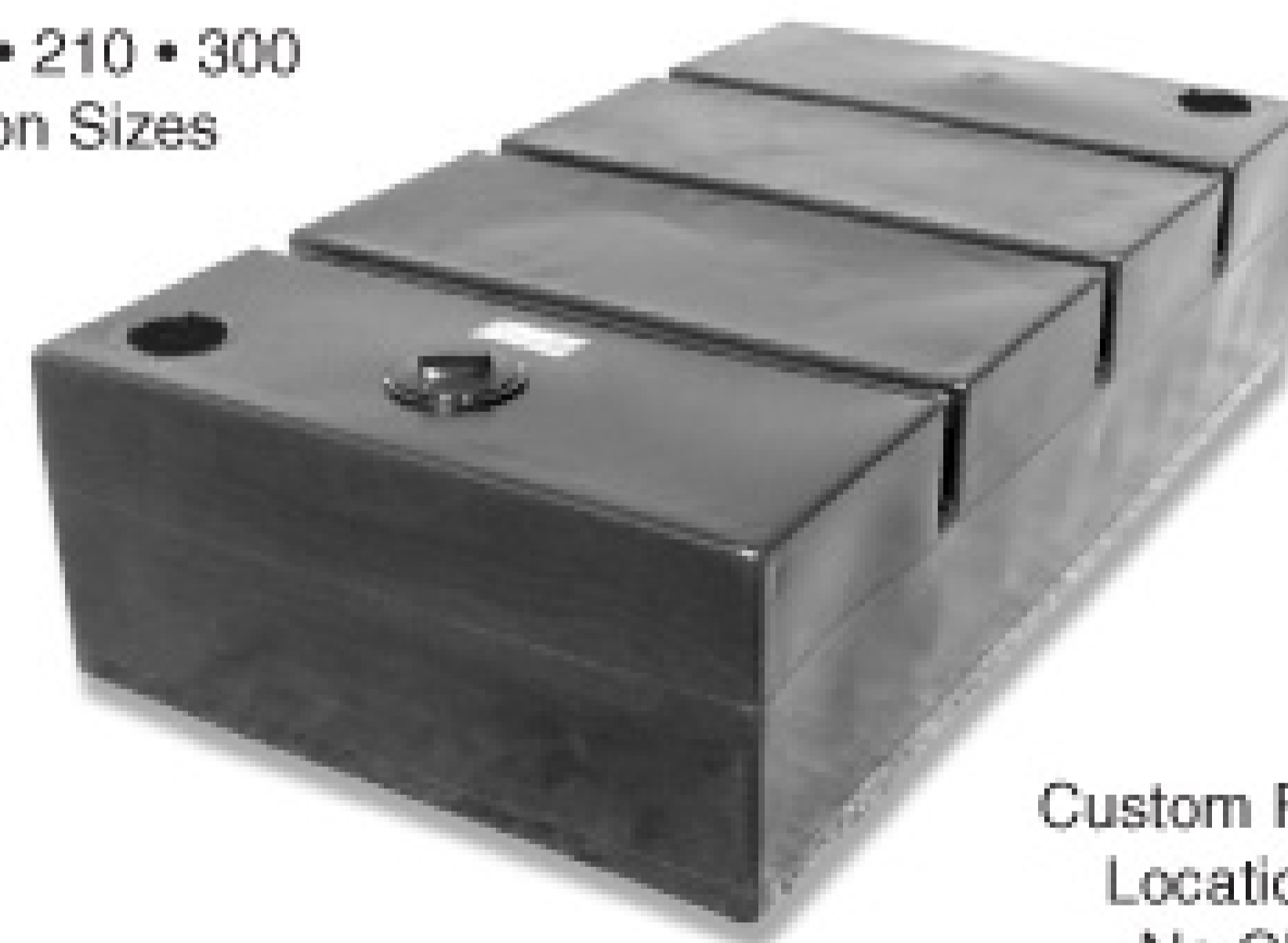

Custom Fitting  
 Locations at  
 No Charge

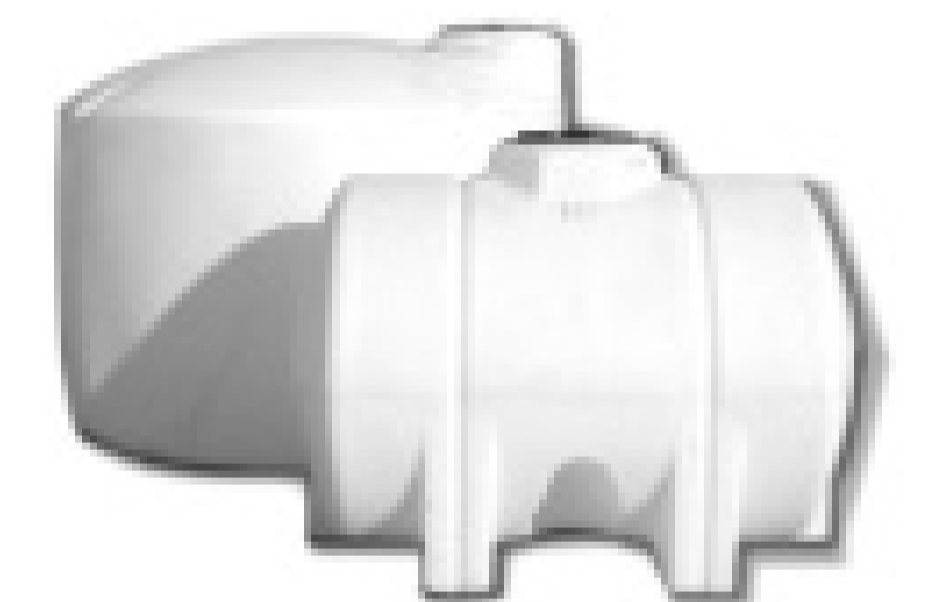

Bulk Storage and Transport Tanks



Septic and Cistern Tanks



Ball Valves and  
 Cam Lock Couplers

## On-Site Water System

### OSW PLUS —

- Tough 65 gal. Tank
- Removable cover for easy cleaning
- 115V On-Demand Pump 3.5 gpm 45 psi
- Low water shut-off
- GFCI Protected
- Filter
- Ships UPS

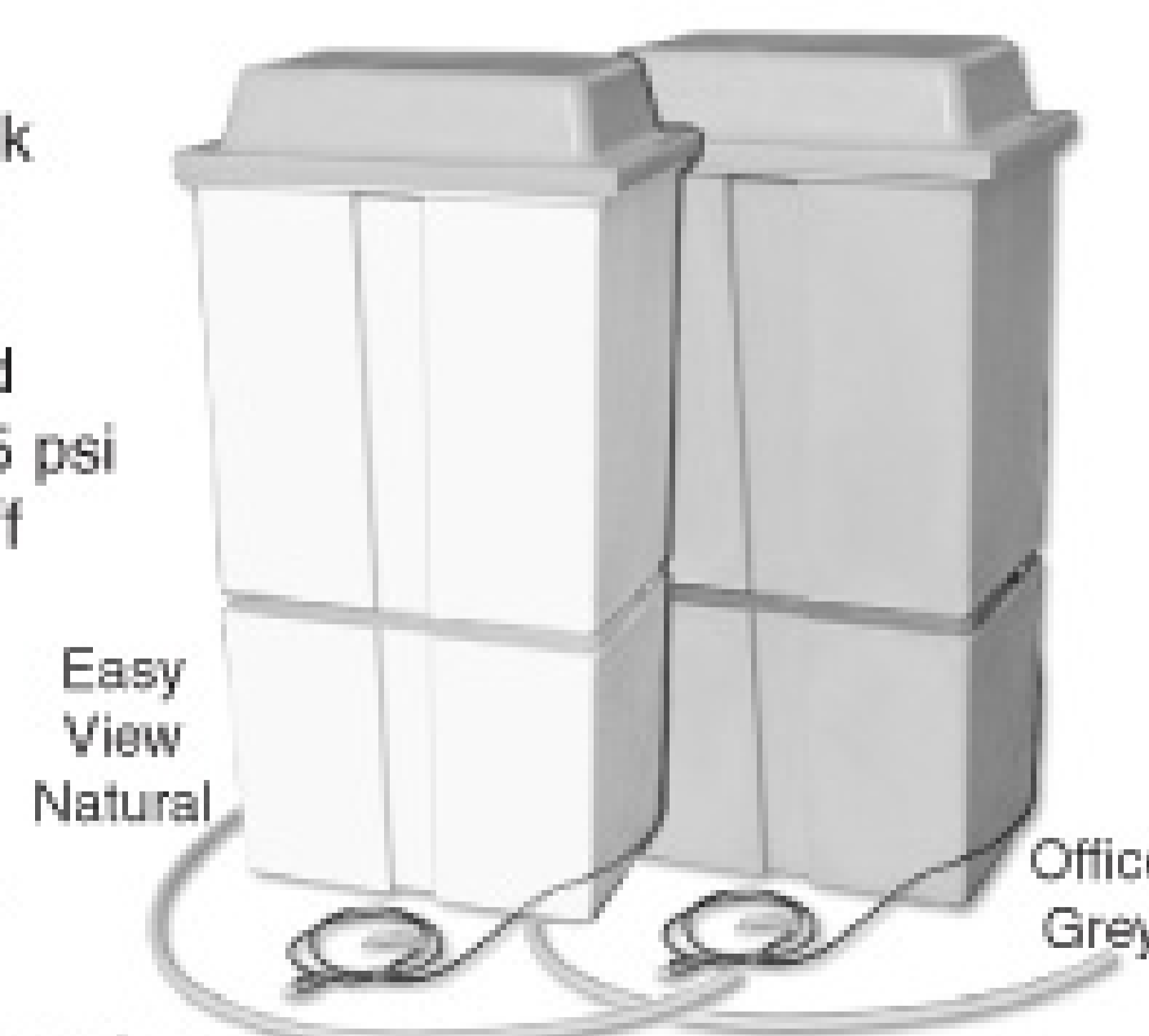

Easy View  
 Natural

Office  
 Grey

### OSW DELUXE —

- Add external fill connection w/float valve

**NORWESCO**

Distributor Since 1987

Nationwide Shipping Points



**1-888-459-8265**

**www.kentuckytank.com**



# TOUGH DAY AT WORK?

The one and only Supersucker® makes the job easier.

- Industry's simplest operation sequence - single control panel set-up that even the newest employees can quickly learn
- Fast, simple unloading procedure makes debris removal easy
- Low maintenance design including one-step filter cleaning system
- High-power vacuum with superior air flow performance
- Heavy-duty, durable construction for long lasting life and use in the most extreme conditions

For more information or to request a FREE demo that shows why the original Supersucker is still the industry's best vacuum loader, visit [www.theoriginalsupersucker.com](http://www.theoriginalsupersucker.com) or call **Super Products** today at 800.837.9711



Easy to Operate; Easy to Clean; and Easy to Maintain.

## Sludge 101

Understanding the solid and scum layers in a septic tank will help you explain necessary system maintenance to reluctant customers

By Roger E. Machmeier, Ph.D.

**Q** I am new to pumping and am fascinated by the biological processes involved in an individual sewage treatment system. I have numerous questions, but will only submit one topic: I want to know what sludge really is. One online encyclopedia says sludge is sewage solids that quickly sink through the floating scum. Another source says sludge is the waste product of the enzymes as they do their job of decomposing waste material.

Further, does sludge consist of many fine particles if allowed to dry and be inspected? Is this material the cause of drainfield glazing?

**A** There are many different kinds of sludge and the nature of the sludge depends upon the process that created it. Certainly, one can refer to any settled material from either bacterial activity or yeast activity as sludge. The consistency of the sludge will be quite different, however, from various kinds of activity.

In a municipal sewage treatment system, the bacterial activity is usually aerobic. This means the bacteria have oxygen for their activity. This sludge has a composition somewhat like soil. The City of Milwaukee added some nitrogen to the sludge from its municipal treatment plant and marketed it as Milorganite. So the "sludge" was basically organic matter with a little extra nitrogen.

I doubt there are reliable references to accurately describe the sludge that accumulates in the bottom of a septic tank. So I will describe septic tank sludge for you. Parts of household sewage that are heavier than water sink to the bottom when the sewage enters the septic tank. Anaerobic bacteria slowly decompose the solids to reduce their volume.

### WATCH SLUDGE LEVEL

The bottom of the septic tank is where the sludge layer forms. As the sludge layer rises, there is less liquid volume in the septic tank and some particles may move through the tank and enter the soil absorption system. The septic tank should be cleaned before this happens. You must educate your customers about this situation.

If a garbage disposer is used and raw vegetables are introduced into the septic tank, these will not be easily broken down, and the sludge layer will accumulate faster. Materials like bones and coffee grounds, when put into the garbage disposer, add to the sludge layer because they do not break down by bacterial action. This is why I recommend homeowners with onsite sewage systems do not install a garbage disposer.

The sewage from a home will also likely contain soap or detergent scum. Scum is lighter than water and floats on the surface of the septic tank. Cooking oils and fats also float and become part of the scum layer. The homeowner should try to minimize the

Onsite sewage treatment maintenance is essential to the continuing operation of an onsite sewage treatment system. This is the message you need to emphasize to your customers.

amount of cooking fat or oil entering the system. The scum layer also occupies part of the liquid volume of the septic tank. If the scum layer gets too thick, some of the scum can be washed out into the soil absorption system. Again, the septic tank needs to be cleaned and pumped before this happens.

Some onsite sewage treatment systems use an aerated tank to promote decomposition of sewage solids. The design usually calls for a settling tank in the sewer line ahead of the aerobic tank. The settling tank takes out the largest solids and basically serves as a septic tank. The aerobic action in the second tank does a better job of breaking down organic solids, but a residue in the aerobic tank must be periodically removed. And it is also called sludge.

In my opinion, if any of the sludge I have described were allowed to dry out, one would not be able to separate and inspect any fine particles.

### PROPER RECYCLING

The proper place for the recycling of sludge from a septic tank or an aerobic tank is on agricultural land. The sludge adds organic matter and nutrients, which are recycled to grow vegetation. The application of sludge must be done with proper procedures to ensure pathogens (dis-

ease-causing bacteria) are not "recycled."

If a septic tank is cleaned periodically, there should be very little, if any, sludge or scum flowing out into the soil absorption field.

The "glazing" you refer to is likely a biological layer called the biomat. The biomat forms from suspended organic particles contained in the effluent from the septic tank. The biomat forms at the soil surface in a drainfield trench or leachfield.

The biomat is anaerobic on the trench side and aerobic on the soil side. The thickness of the biomat depends on the quality of the effluent from the sewage tank and the porosity of the soil. The biomat allows liquid to move through it. The biomat is a treatment layer that removes pathogens.

The biomat will always form in a soil absorption system. The rate of liquid movement through the biomat is called the Long Term Absorption Rate. The rate is dependent upon the texture of the soil. Larger absorption areas are needed in clay soils as compared to loam soils.

Onsite sewage treatment maintenance is essential to the continuing operation of an onsite sewage treatment system. This is the message you need to emphasize to your customers. ■

Readers are welcome to submit questions to the Answer Man. Send your question to COLE Publishing by e-mail to editor@pumper.com, by fax to 715/546-3786; or by mail to P.O. Box 220, Three Lakes, WI 54562. We will pass your question along to Dr. Machmeier.





# TRANSPORT TRUCK SALES, INC.

Ask for Scott or Frank – 888-395-7551  
After hours call Scott at 816-590-4076



## What Does It Take To Be A "Qualified Chassis"?

Pass our 12 point checklist. (We send this out with every quote!)

Pass a D.O.T. certified inspection!

Pass the warranty inspection!

## What Does All This Do For You?

Nationwide drive train warranty for 2 years/ 200K miles! (restrictions apply)

A tough truck that is ready to work as hard as you do!

## YOUR TRADES ARE WELCOME!

Searching For A Brand New Chassis?  
We Have Them In Stock!



**2002 Freightliner FL-112**, CAT C-10 350 HP, 9 spd, jakes, 14,600# fronts, AC, double framed, new 3600 gallon Alum. vac tank, new Masport HXL-400 vac Pump.

Call For Pricing!

**2-YEAR 200,000 MILE DRIVE TRAIN WARRANTY**



**2001 Freightliner FLD120**, CAT C-15 475HP, 10 spd, jakes, AC, double framed, new 3360 gallon steel vac tank, new Masport HXL-400 vac pump.

Call For Pricing!

**2-YEAR 200,000 MILE DRIVE TRAIN WARRANTY**



**2002 Mack CH613**, E-7 400 HP, 10 spd, jakes, AC, double framed, LOW MILES, new 3360 gallon steel vac tank, new liquid cooled Masport HXL-400 vac Pump.

Call For Pricing!

**2-YEAR 200,000 MILE DRIVE TRAIN WARRANTY**



**2001 Mack CH613**, E-7 300 HP, 10 spd, AC, double framed, new 3360 gallon steel vac tank, new liquid cooled Masport HXL-400 vac Pump.

Call For Pricing!

**2-YEAR 200,000 MILE DRIVE TRAIN WARRANTY**



**2001 Mack CH613**, E-7 380 HP, 10 spd, jakes, AC, double framed, LOW MILES, New 3360 Gallon Steel Vac Tank, New Liquid Cooled HXL-400 Masport Vac pump.

Call For Pricing!

**2-YEAR 200,000 MILE DRIVE TRAIN WARRANTY**



**2000 Freightliner FLD120 Severe Duty**, 12.7L Detroit 430 HP, 13 spd, jakes, double framed, 18# fronts, 46# rears, new 3360 gallon steel vac tank, New Liquid Cooled HXL-400 Masport vac pump.

Call For Pricing!

**2-YEAR 200,000 MILE DRIVE TRAIN WARRANTY**

Delivery Available Anywhere in the Lower 48!!

# Agitation SAVES Aggravation!

CHOICE OF 2', 4' & 6' EXTENSIONS



Patent Pending

**Guaranteed To Mix Up Septic Tanks & Grease Traps!**

**High speed rotation** busts the crust and removes solids right off the bottom of the tank into a total liquid form  
**Field tested and proven** to mix a residential tank in 5 minutes or less – takes approx. 15 minutes to agitate a 5000-10,000 gallon grease trap

CHECK OUT OUR NEW INFORMATIONAL DVD  
[PUMPER.COM/VIDEO.PHP](http://PUMPER.COM/VIDEO.PHP)

Schmitz Brothers L.L.C.  
 PHONE 763.878.2296  
 FAX 763.878.2299

**1.888.878.2296**

**CRUST BUSTERS**  
 E-MAIL [pete@crustbusters.com](mailto:pete@crustbusters.com)  
 WEB SITE [www.crustbusters.com](http://www.crustbusters.com)



ASK ABOUT OUR "BUSTER BRACKETS" FOR TRUCK MOUNTING

## \$ We've Got the Money \$

For All Your New and Used Equipment Needs

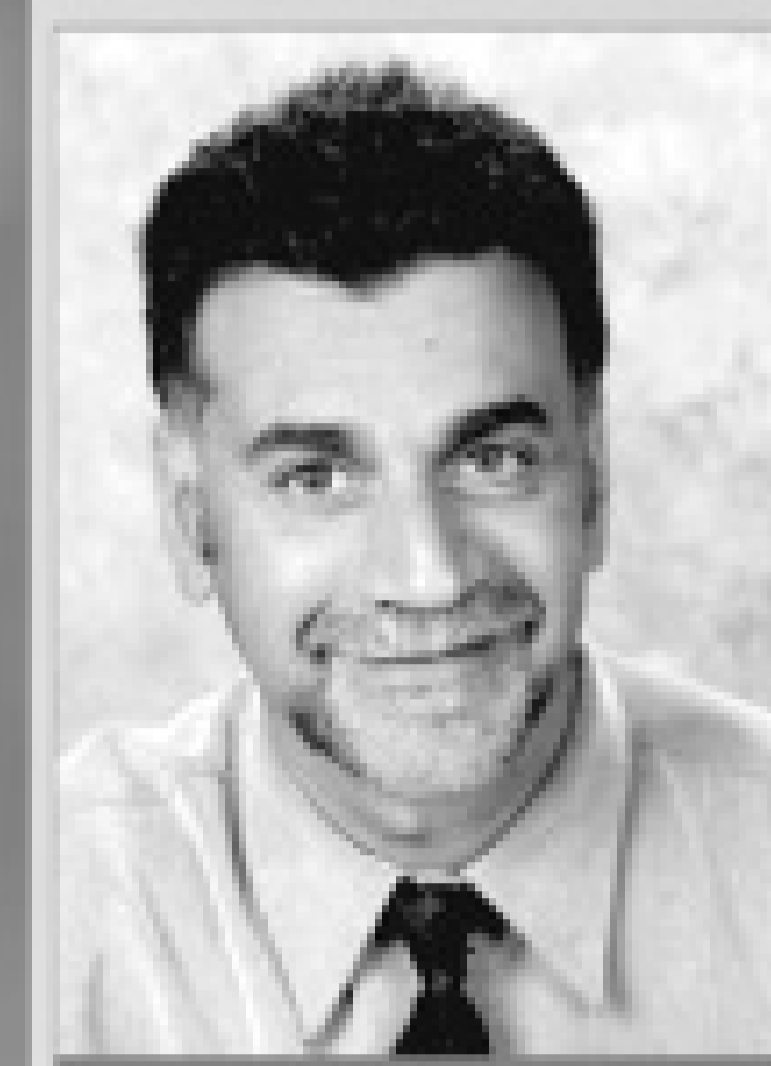

Chuck Territo



Mike Rausch

- \$250k Application Only
- Simple Approval Process
- Lease or Loan Options
- New & Used Equipment
- Flexible Finance Options
- Start Up Programs

Let us put our 35 years of experience to work for you! Call today and see why...  
**It pays to lease with us!**

Granite Leasing Co.

**800.246.7997**  
[www.graniteleasing.com](http://www.graniteleasing.com)



THANKS, TANMAR

STAINLESS STEEL & STEEL UNITS - CALL FOR INFORMATION

TANKS TO YOUR SPECIFICATIONS

## PUMP DISTRIBUTOR

BATTIONI      JUROP  
 BOWIE        MASPORT  
 FRUITLAND    MORO

Pump Rebuild Kits In Stock

**CALL TODAY FOR INFORMATION OR PRICES ON TANKS, PUMPS AND ALL PARTS**

Secondary Shutoffs

Sight Glasses, Valves & Couplings

12" Primary Shutoffs

21" & 36" Manways



### BASE TANKS INCLUDE:

1/4" Thick Steel • Pipe Reinforced Baffles • Primary Shutoff Flanged and Dished Heads • 21" Top and Rear Hatches Full Length Under Carriage on Bottom of Tank

#### BASE TANK PRICING

2100 GALLON .....	\$5800	3360 GALLON .....	\$8140
2500 GALLON .....	\$6740	3570 GALLON .....	\$9000
3000 GALLON .....	\$7575	4000 GALLON .....	\$9920



**800.364.7307**

2100 EAST BOOTH ST. • SEARCY, AR 72143  
 Fax: 501.279.0003 • E-mail: [sbs@cdlworld.net](mailto:sbs@cdlworld.net)

Experience the raw power of...

**SURCO®**

**BLUE • MUSCLE™**

THE MOST POWERFUL PORTABLE TOILET DEODORANT IN THE INDUSTRY

**Stock up and Order Today!**

**1-800-556-0111**

**or on the web at:**

**www.surcopt.com**

**SURCO®**

**– Since 1946 –**

292 Alpha Drive • Pittsburgh PA 15238

1-800-556-0111 412-252-7000

www.surcopt.com



©2008 SP

# chempace<sup>®</sup>

corporation

www.chempace.com

*Serving the Industry for Over 40 Years!*

## One-Stop-Solutions For PORTABLE SANITATION & SEPTIC & GREASE HAULERS

**BUYING DIRECT  
ALWAYS EQUALS  
COST SAVINGS**



### Big Shot<sup>®</sup> Con2 & Con2 Plus

- Super Strength Concentrate
- Non-Formaldehyde
- Ideal for Summer Use

**NEW  
FEATURES  
ON 3 GREAT  
PRODUCTS!**

**NEW  
FORMULA!**

**ENHANCED  
FRAGRANCE!**

**STRONGER  
DYE**

### Ultra PowrPak XL

Convenient Carry Pail  
Effervescence



**SEPTIC TANK  
ADDITIVES \$6** (Per Pkg)



**NEW  
PACKAGING  
OPTION**

**LONG  
LASTING  
PINK CUBE  
\$160** (Per 4x5 lbs.)

*Designed to last in  
hard to service  
liftstations/grease traps*



Thanks for  
visiting us!

**SEWER FOAM \$59.75** (Per Pail)

*Reduce solids and hydrogen sulfide odors -  
Economical approach to sewer maintenance.*



**BUY DIRECT CALL CHEMPACE  
1-800-423-5350**

*Quality People Doing Quality Work*

### Industrial Vacuum Units

DOT Code & Non Code Vacuum Trailers



### Vacuum Septic Units

Aluminum or Steel  
Tanks in a Variety  
of Capacities



### Portable Restroom Service Units

**IN STOCK - 650/300 gal.**  
Call for Details  
Ready for Immediate  
Delivery -  
Priced at  
**\$54,500**



### Mini Vac Trailers

DOT  
Code  
& Non  
Code



### Slide-In Units



**IN STOCK - Slide-In Portable  
Restroom Units - Call for Details  
Industrial Skid-Mounted Units  
Also Available**

# Marsh

**INDUSTRIAL**

P.O. Box 1107 - 135 E Mile Road - Kalkaska, MI 49646  
p: 231.258.4870 - f: 231.258.2019 - sales@marshind.com

**800.952.1537 - WWW.MARSHIND.COM**

**In these tough economic times, trust the experience that**  
**52 YEARS OF MANUFACTURING**  
**and a dedicated team of professionals can bring you.**

# FRUITLAND VACUUM PUMPS



**Tool & Die Maker**  
42 yrs.



**Machinist**  
26 yrs.



**Machinist**  
43 yrs.



**Tool & Die Maker**  
29 yrs.

*"A Few of our  
Long Term  
Professionals"*



**Markets:**

- Industrial •
- Oilfield •
- Septic •
- Grease •
- Environmental •
- Wastewater •

**Used and Proven by  
World's Top Liquid  
Vacuum Service Companies.**

**Fruitland Tool & Manufacturing**

*"Committed to Quality, Reliability, and Guaranteed Performance"*

Contact us today: **1-800-663-9003**  
 Visit us @ [www.fruitland-mfg.com](http://www.fruitland-mfg.com) For more info.

**Come In We're**  
**OPEN**  
[www.pumper.com](http://www.pumper.com)

**DECALS • SIGNS • LABELS • & MORE!**

**We Specialize in Waste Management Labeling Solutions**

- Service Records
- Logo Signs
- Lock out Tags
- Gender Signs
- NRC Records
- Service Call Forms
- Warning Decals
- Service Tags

**All Printing & Signs Can be Customized at No Additional Charge**

**Anchor Graphics**  
Labels & More

Tele: 972-422-4300 • 1-800-875-7859  
 Fax: 972-422-4311 • [www.anchorgraphics.com](http://www.anchorgraphics.com)  
 E-mail: [info@anchorgraphics.com](mailto:info@anchorgraphics.com)

**435 GALLON VACUUM TANK**

**ALUMINUM**

- 1/4" Aluminum Construction
- Conde Super 6 Pressure Vac Pump with 5.5 hp Honda Electric Start
- 12 Volt Water Pump
- 300 Waste/135 Fresh
- 25' Hose and Wand
- 2" Sight Eyes in Waste
- Sight Tube on Fresh Water
- Completely Self-Contained
- Ready to Work

**\*OTHER SIZES AVAILABLE\***

**Robinson Septic Service Inc.**

125 Rockrimmon Dr., Bellefonte, PA 16823 • 1-814-353-0263 • email: [honeydippers@aol.com](mailto:honeydippers@aol.com)  
**1.800.252.3848** • [www.robinsonseptic.com](http://www.robinsonseptic.com)

# CLASS ACTS

## NAWT meeting at the Pumper & Cleaner Expo is the stage for major industry awards

By Jim Kneiszel

Major liquid waste industry awards were delivered at a meeting of the National Association of Wastewater Transporters during the Pumper & Cleaner Environmental Expo International Feb. 27.

NAWT's breakfast membership meeting included award ceremonies honoring NAWT's Man of the Year, U.S. Environmental Protection Agency official Bill Hasselkus, and the Ralph Macchio Lifetime Achievement Award, which was awarded posthumously to New Mexico pumper Rocky Horton.

The awards were presented by NAWT President Tom Frank, COLE Publishing co-founder Bob Kendall and Macchio.

### MAN OF THE YEAR

At one point, it would have seemed highly unlikely that Hasselkus would win an award from an association of private waste haulers. As the 42-year veteran of government regulation recalls it, his introduction to pumping contractors at the Pumper & Cleaner Expo was contentious.

"The first pumper show that I came to was eight or nine years ago and they were picketing us because they thought we were encouraging big utilities to take the role of the pumpers,"

Hasselkus recalled. The pumping community's skepticism of the EPA was based, Hasselkus said, on one misstatement he made about haulers in an issue of *Pumper*.

"They seized on that and decided we were trying to put the pumpers out of business," he said. "We had to learn to communicate better." Hasselkus said it was never the agency's intent to reduce the important role played by liquid waste carriers. He only wanted the government to become a partner with haulers to improve upon safe and professional handling of septic waste.

### TRAINING GRANTS

Hasselkus and Tom Ferrero, executive director of NAWT, said the groups have become highly effective partners, and in doing so have watched the industry raise its level of professional service and its image. Over the years, the EPA, NAWT and 11 other national organizations have forged a Memorandum of Understanding in support of onsite septic systems that serve approximately 25 percent of the country's population and 37 percent of new home development.

In recent years, Hasselkus has been an advocate for the pumping community at EPA as the agency issued training grants to NAWT for inspection and vacuum truck training. Those programs have taken off and become

"It's hard to think of a bunch of more dedicated and hard-working people than the pumpers. It's a hard business and that's a tough job."

BILL HASSELKUS



NAWT President Tom Frank (left) presents the Man of the Year Award to EPA official Bill Hasselkus. (Photos by Jim Kneiszel)

self-sustaining NAWT offerings, while both groups work together to strengthen the industry. And NAWT took a step further with the vacuum truck training during the Pumper & Cleaner Expo, where it was filmed for an online version to be offered soon.

Ferrero said pumpers have overcome their initial skepticism of the EPA, and much of that is because of Hasselkus.

"The first couple of years were bumpy with the EPA. But Bill was a down-to-earth person, supportive of the industry and the individuals in the industry," Ferrero said. "He appreciates that NAWT wants to work to improve the industry and realizes that training is important."

Ferrero said that in states where regulations require pumper training, contractors are now clamoring for the NAWT programs. These mandates have made states like Arizona and New Mexico a hotbed for the sessions.

### APPRECIATES AWARD

"The industry is still slow (to adapt). But little by little, we're better off than we were five years ago," he said.

Hasselkus said NAWT approaches its programs the right way and succeeds in making the case for private industry doing a good job at providing an essential service.

"NAWT is one of the best professional organizations I have ever been associated with. I've gotten a lot of awards, but this one I appreciate as much or more than any of them because I know where it came from and the caliber of the people here," he said.

His praise goes beyond NAWT and to the entire pumping community. Hasselkus enjoys his annual trip to the Expo not just to talk environmental policy, but to meet the workers who handle the business end of a vacuum hose. He says they're constantly working to build on industry professionalism and fight negative perceptions about the job.

"It's hard to think of a bunch of more dedicated and hardworking people than the pumpers," he said. "It's a hard business and that's a tough job."

Ferrero said Hasselkus continues to be a proponent for pumper training, coming to NAWT meetings and fighting misperceptions about the difficulty of working with a giant agency like the EPA.

"His favorite line is, 'I'm from the government and I'm here to help you.' ... And he actually does," Ferrero said.

### LIFETIME ACHIEVEMENT AWARD

The Ralph Macchio Lifetime Achievement Award is usually cause for a rousing celebration. But bestowing the honor this year was a bittersweet task. That's because the recipient of the 2009 award, Rocky Horton, owner



Left, Ralph Macchio (center) is flanked by Brent (left) and Marlon Inman, who accepted the industry's Lifetime Achievement Award on behalf of Rocky Horton (below).



of Mighty Vac Pumping Services, Clovis, N.M., died in a work-related accident.

On Dec. 23, 2007, Horton responded to a plumbing emergency, volunteering his services to an 80-year-old friend whose water heater sprang a leak. While cleaning up the spill on the early morning call, Horton reached for a falling lamp and was electrocuted. The accident took the life of the dedicated 44-year-old pumper and left a widow, Suzahn, and two young children, Rockell, 9, and Ruger, 7.

"Rocky was a people person and he loved everybody. If you met him, he was your friend for life," said Brent Inman, Horton's brother-in-law. "He never charged a church for a job or a pastor for washing his car. If it was a God thing, it was a free thing."

#### STARTED WITH CAR WASH

Inman and his father, Marlon Inman, collected the Lifetime

Achievement Award statue at the Expo, as well as a financial prize that will go toward an education fund for Horton's children.

In the mid-1990s, Horton bought his first vacuum truck to pump out the pits at his car wash in Clovis, a city of about 32,000 at the Texas-New Mexico border, 100 miles west of Lubbock, Texas. In 1996, his small pumping operation was featured in *Pumper*, with Horton in the magazine's cover photo. Later on, Horton added portable restrooms to his offerings, and both Brent and Marlon Inman joined the company.

"He was an entrepreneur. He wasn't afraid to jump out and take the opportunities," Brent Inman said. "He was a real go-getter and could see things."

After Horton was killed, the Inmans and Suzahn Horton soldiered on with the business. The family has attended the Expo several times over the years and intends to keep operating.

Horton's family has relied on their faith to get through the tragedy and move forward, Inman explained.

"God knows when we are born and he knows when our time is coming," he said. "It just so happens that was Rocky's time. We may never understand that, but that's OK."

#### NAWT BOARD RE-ELECTED

The slate of NAWT officers was re-elected for 2009. They are Tom Frank of Ohio, president; Roger Winter of Ontario, vice president; Mitch Okerstrom of Minnesota, treasurer; and Ferrero, secretary. ■



# Lely Waste Solutions, LLC

Temple, TX | 800 367 5359



1550 Gallon Steel Portable Toilet Unit  
1100 Waste & 450 Fresh Water



300-100  
Portable Toilet  
Unit In Stock



400-200  
Skid Mount  
Portable Unit  
In Stock





Temple, TX  
800 367 5359  
Fax 254 938 7204  
[www.lelywaste.com](http://www.lelywaste.com)

**Bruce Curry**  
bcurry@lelywaste.com  
**Earl Ballard**  
eballard@lelywaste.com



**BLACK TIE**  
MANUFACTURING

**SIMPLY THE BEST  
TRAILER BUILT...**



...Supported by the **BEST Re-Rental Program Available**  
(**\$1,500,000 paid to partners in 2008**)

**CALL NOW FOR A QUOTE AND RENTAL MARKET ANALYSIS**

**877-253-3533**

[www.blacktiemanufacturing.com](http://www.blacktiemanufacturing.com)

©2008, Black Tie Manufacturing, Inc.

**MOBILE RESTROOM SUITES**



**CUSTOMIZE  
YOUR OWN!**

**WORKMATE**

**PORTABLE TOILET & VACUUM TRUCKS**

Serving the Pacific NW



Toilet Trailer



Portable Toilet Service Truck



Septic Service Truck



Portable Toilet Service Trailer



**WORKMATE TRUCKS**

A Division of FMI Truck Sales & Service  
Portland, Oregon

**1-800-927-8750**

Ask for **JOHN BARRET** or go to [www.fmitrucks.com](http://www.fmitrucks.com)

Have you seen the  
**Pumper**  
**E-Zine?**

Vacuum Trucks & Components • Fleet Management & Maintenance

DEDICATED TO THE LIQUID WASTE INDUSTRY  
**Pumper**  
March 2009 [www.pumper.com](http://www.pumper.com)

**MAN OF  
STEEL**

Shop-savvy Minnesota contractor shares truck buying and repair tips



Go to [pumper.com](http://pumper.com) to view the e-zine.



Tanks  
made with  
attention  
to detail.

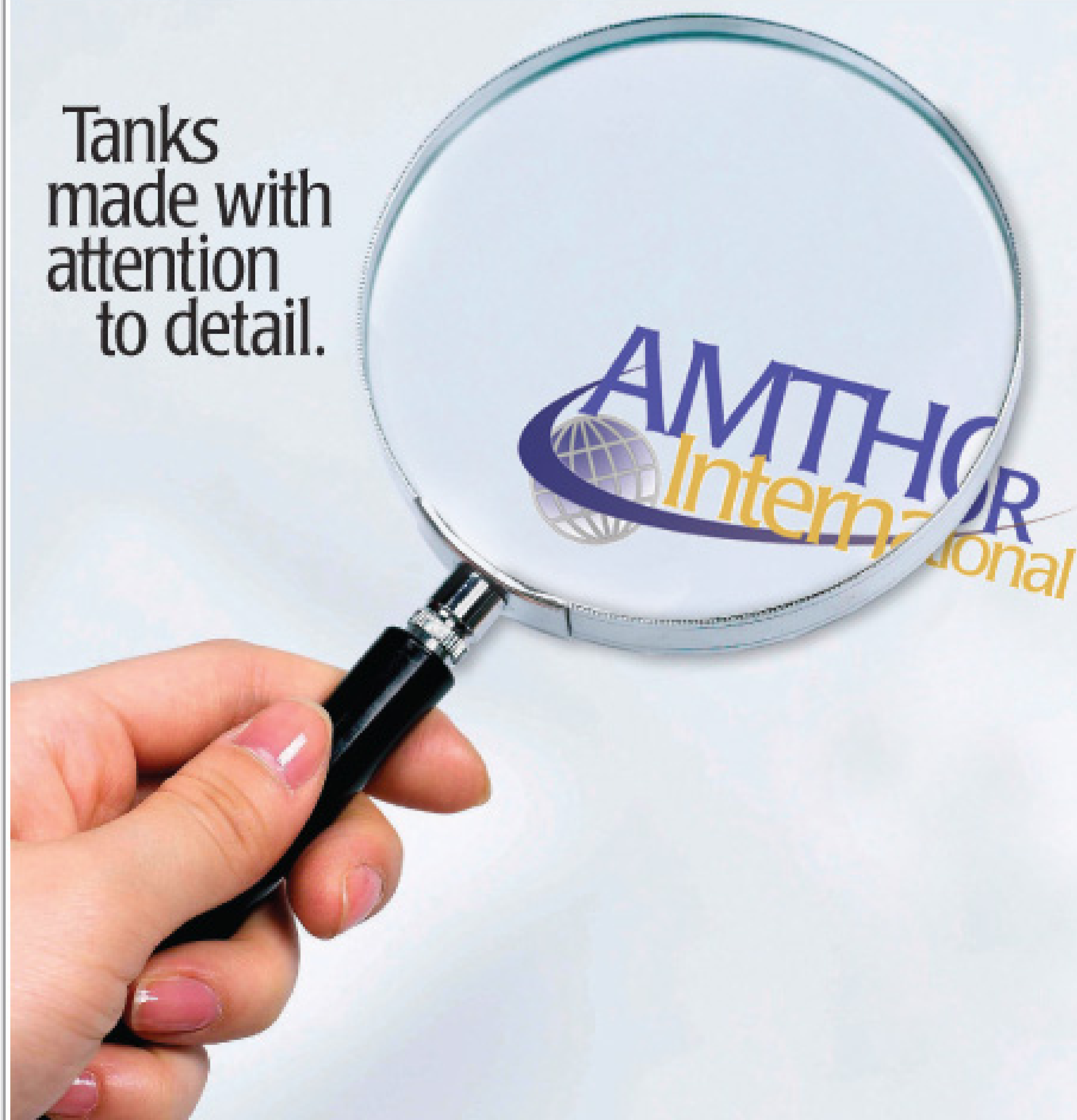

# Amthor is Innovation

Looking for a new tank? Think Amthor.

At Amthor, we deserve our reputation for quality, innovation and expertise. Our products meet the demands of today's consumer AND exceed industry expectations. With a nationwide distribution network, delivery is simplified. Plus, you'll enjoy exceptional customer service. Visit us online for specifics.



For your nearest distributor contact: Hank Vanderveen  
VA Office: 434.656.6233 • Tel/Fax: 252.293.1284 • Cell: 845.494.0104



Have It  
Your Way



Rent - Lease  
Lease/Purchase

27" Late Model  
Vac Trucks



Spectrum Industrial Services - (205) 664-2000 or Toll Free (888) 739-0838

## FLATS NO MORE Permanent Tire Sealant 251-802-5861

**The Puncture Preventive Solution**  
Fix flat tires before they happen!  
• Trucks • Construction & Mining Equipment • Cars • Buses  
• Pickups • Agricultural Equipment • ATV's



**Onroad -  
Heavy  
Truck  
Fleets**



**Install  
In Any  
Tires**



**Will Not  
Affect  
Balance  
Tested  
At High  
Speeds**



**Offroad  
Anything**



- Prevents And Stops Leaks
- Inhibits Tire And Rim Leaks
- Seals Punctures Up To 1/2 Inch
- Can Extend Tire Life Up To 25%

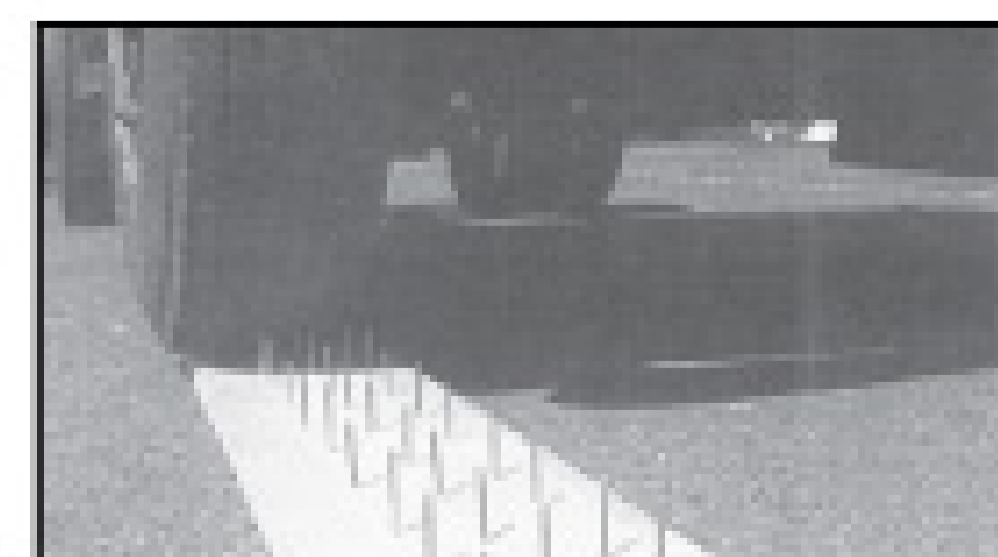

**Tractor  
Tanker  
unit 73  
construction  
spike**



**DEALER INQUIRIES WELCOME**

**www.flats-no-more.com**

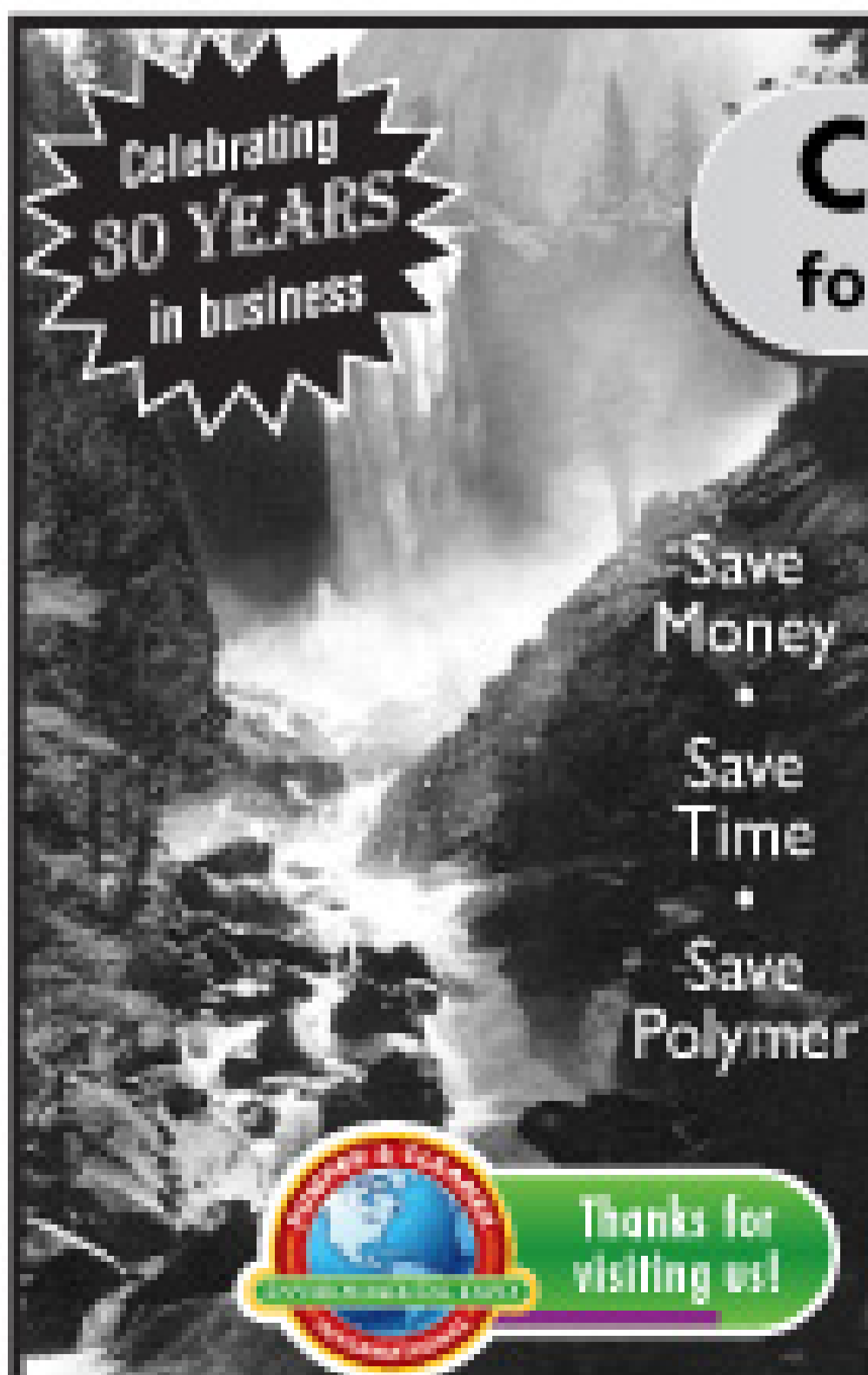

## Coagulants and Flocculants for Septic, Grease, Municipalities and Industry

- Save Money
- Save Time
- Save Polymer

- Dewatering polymers for all dewatering equipment
- All forms: Dry and Emulsion
- Variety of packaging sizes to meet customer needs
- Both East & West coast shipping points
- Expert technical staff
- Specific solutions for our customers

Call Toll-free:  
877.771.6041

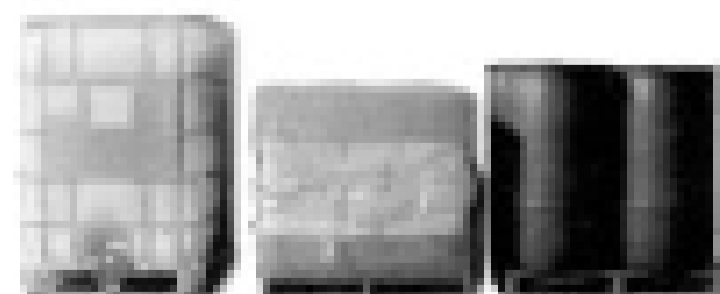

**Aqua Ben Corporation**  
1390 N. Manzanita St. • Orange, CA 92867  
www.aquaben.com • sales@aquaben.com

# utile

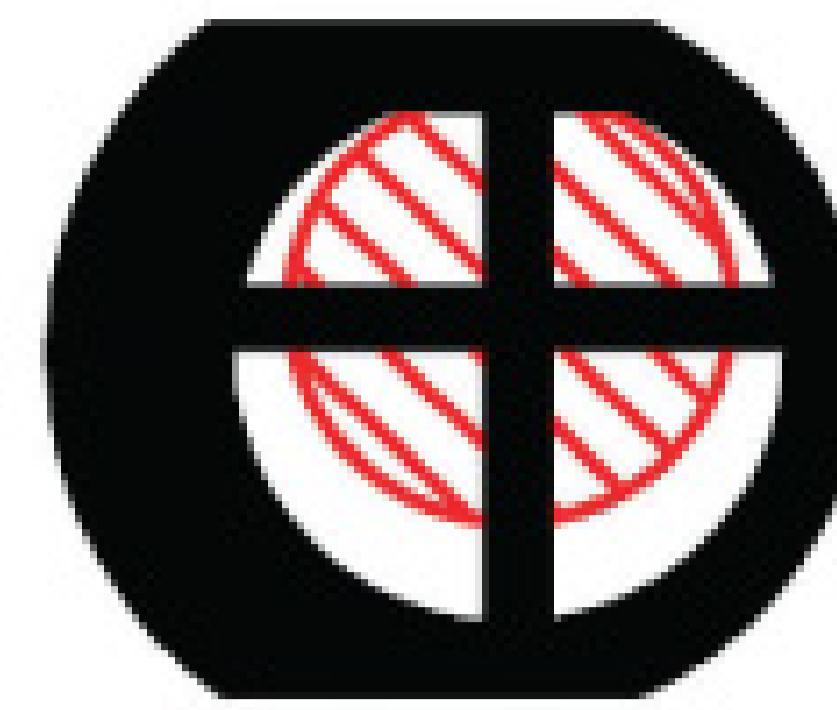

## Com Vac Systems

*Where Quality doesn't cost, it pays - reliability and performance you can trust*

- Aircooled to 535cfm and 28"Hg/30psig
- Watercooled to 905cfm and 28"Hg/30 psig
- Heavy duty – Reliable
- Continuous high vacuum
- Automatic lubrication
- Quiet Operation - Slow running
- Over 30 years US market experience
- A range of models to suit any application
- Suitable for slide installation



LW825

- Septic
- Oilfield
- Haz Mat
- Wastewater
- Industrial

**Call today - ComVac Systems Inc. – Contact: 1-800 243 7986**

**\*Dealer Inquiries invited\***

**The Utile Engineering Co. Ltd**

**Irthlingborough, Northamptonshire, England, NN9 5UG**

**Tel: +44 (0) 1933 650216**

**Fax: +44 (0) 1933 652738**

**Email: sales@utileengineering.com**

**Web: www.utileengineering.com**

## We Have Money To Loan



If you need equipment to grow and your bank said "NO," call "JIM THOMAS"

We are not affected by the economy. Conserve your working capital. Keep existing credit lines intact, and enjoy the security of knowing financing is there when you need it. We offer loan and leasing plans tailored to individual needs.

- Portable Toilets
- Sewer Equipment
- Pumper Trucks
- TV Inspection
- Water Jetters
- New and Used Equipment
- Vacuum Trucks

- ◆ Programs offer longer terms for older equipment.
- ◆ We do start ups.
- ◆ 90 Day Delayed Billing.
- ◆ Seasonal Payment Programs Available

**Get Pre-Approved for the Pumper & Cleaner Environmental Expo**

Prompt, no nonsense financing designed to meet individual requirements. Payment plans that are generally lower than other finance plans. With years of experience, we understand the competitive nature of your business.

**We're prepared to act quickly and decisively!**

**Toll-Free 877-333-4539 • www.keycommercial.com**



## One Complete Package

[promonthly.com](http://promonthly.com)

[cleaner.com](http://cleaner.com)

[pumper.com](http://pumper.com)

[mswmag.com](http://mswmag.com)

[onsiteinstaller.com](http://onsiteinstaller.com)

[pumpershow.com](http://pumpershow.com)

[pumpertrader.com](http://pumpertrader.com)

[eq-mag.com](http://eq-mag.com)

[tpomag.com](http://tpomag.com)

[septicyellowpages.com](http://septicyellowpages.com)

[sewerpages.com](http://sewerpages.com)

**COLE Publishing**

**1.800.257.7222 | 715.546.3346**

# HOSE ASSEMBLIES

MANUFACTURED TO YOUR EXACT HOSE REQUIREMENTS BY THE LEADING SOURCE IN HOSE FABRICATION.



**LOWEST PRICES  
GUARANTEED  
ON ALL OF OUR**

**"QUICK-SHIP"**

ITEMS

INCLUDING  
HOSE & ASSEMBLIES  
COUPLINGS • VALVES • ADAPTERS

300EPDM • 180AR • 180HR • 180BL  
390SD • 220RS • GREEN PVC  
KANALINE SR • KANAPOWER AT

Genuine

**Kanaflex®**

Assemblies by

**ABBOTT**

300EPDM HOSE NOW AVAILABLE IN COLORS

GREEN/BLACK - BLUE/BLACK - RED/BLACK



**RUBBER COMPANY, INC.**

1700 Nicholas Blvd. Elk Grove Village, IL 60007

www.pumperhose.com

1-800-852-1855 FAX: 847-952-0156

[sales@pumperhose.com](mailto:sales@pumperhose.com)

# ABERNETHY

**WELDING & REPAIR INC.**

Call Bill Abernethy at **1.800.545.0324**

Fax: 828.324.2401 • E-mail: [abernethyinc@charterinternet.com](mailto:abernethyinc@charterinternet.com)

authorized distributor for:

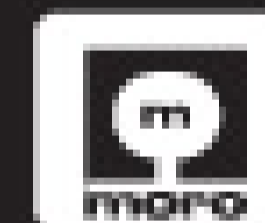

NVE

Wittig

Masport



2009 Peterbilt, auto trans, 26000 GVW, AC, 1500 gallon portable service unit, HXL75V Masport pump. **IMMEDIATE DELIVERY!**



2009 International 4400E Series, 260 hp diesel DT 466 engine, 6-spd. trans. and world class auto, air brakes, 33,000 GVW, air conditioned, 2500 gal. tank, Masport HXL400 pump. **IMMEDIATE DELIVERY!**  
Also, 2500 and 3500 gal. tanks **READY FOR IMMEDIATE DELIVERY.**

• **Ford • GM • International**

**2009 INTERNATIONAL 4400**

2500 gal. tank, (1) 6-spd. trans. & (1) auto trans.

**2-2009 KENWORTH T300**

2500 gal. tank, auto trans., 260 hp

**NEW PORTABLE TOILET UNITS:**

**2008 5500 CHEVROLET**

1000 gal. 700 waste / 300 fresh, 2 Wheel Drive & 4 Wheel Drive available

**3-2009 INTERNATIONAL 4300**

1500 gal. portable toilet service units, auto trans.

**2009 KENWORTH**

1500 gal. portable toilet service unit, auto trans.

**2-2008 PETERBILT**

1500 gal. portable toilet service unit, auto trans.

**WE WILL CUSTOM BUILD YOUR TANK UP TO 5000 GALLONS!**

600-1500 Gallon Portable Toilet Trucks: Our Truck or Yours

**COMPLETE PARTS AND IN-HOUSE SERVICE**

Cook Compression Vanes • Moro • Battioni • Jurop • Masport • Fruitland • NVE • Powerflo • Plus many other brands

OVERNIGHT DELIVERY ON PARTS • SAME DAY SHIPMENT ON PUMPS

**SEVERAL GOOD, OLDER  
TRUCKS TO CHOOSE FROM:**

- 2006 International - 2500 gal. tank, 65,000 miles, excellent condition
- 1998 Volvo - 4000 gal. tank
- 1997 Volvo - 3500 gal. tank
- 1995 Chevrolet - 1800 gal. tank, gas, under CDL
- 1995 International - 2500 gal. tank

**PORTABLE TOILET UNITS:**

- 2007 Chevrolet 5500 - 2-wheel drive. Call for prices. Ready to go!
- 2007 Chevrolet 5500 - 4-wheel drive. Call for prices. Ready to go!
- 1999 International 4700 - 1100/400 gal. tank, good condition
- 1999 Sterling - 1500 gal.
- 1997 Ford F450 - 800 gal. tank
- 1994 UD - 1200 gal. tank

**MANY OTHER UNITS IN STOCK!**

**CALL FOR UPDATE**

Check with us on financing for the purchase of a new truck!

**WE SPECIALIZE IN PORTABLE SANITATION AND SEPTIC PUMPING EQUIPMENT**

www.abernethywelding.com

# Your Employee's First Day

Whether you're hiring for the first time or adding to staff, it pays to be up-to-date with the legalities of bringing people on board

By Fred S. Steingold

If you're hiring your first employee, you need to know the steps to take on that first day at work. And even if you're hiring your tenth employee, you still want to make sure you're up-to-date on what to do.

Most importantly, some government paperwork is required. You'll need at least three forms: the I-9 from the Office of Homeland Security, the W-4 from the IRS, and the New Hire Reporting Form from your state government. In addition, your business will have to display mandated posters.

**Form I-9, Employment Eligibility Verification.** Federal law requires employers to hire only people who may legally work in the United States: citizens and nationals, lawful permanent residents and aliens authorized to work.

Accordingly, all employers and employees must complete Form I-9. This includes employees who are U.S. citizens. If asked, you must provide your employee's form to the U.S. Department of Labor or the Department of Homeland Security.

Your employee completes Section 1 of the form. An employee who can't do it on his or her

own can get help from a preparer (if your employee is not fully literate) or a translator (if the person is not fluent in English).

You must complete and sign Section 2, Employer Review and Verification. Within three business days of the date employment starts, you need to examine evidence of the worker's identity and employment status. Do this by looking at documents the government has listed as acceptable proof of identity and employment eligibility. The employee is free to select from among the items on the list.

Finally, there is Section 3 of the Form I-9. Don't worry about this section now. You'll only use it to update or verify the worker's status. This might happen, for example, when the expiration date for work authorization has been reached. Or it might happen if you rehire the employee within three years of the date when the form was originally completed.

Keep the completed form, along with any photocopies of related documents, in a file that's separate from other employee records.

**Form W-4, Employee's Withholding Allowance Certificate.** This IRS form helps you

Federal law requires employers to hire only people who may legally work in the United States: citizens and nationals, lawful permanent residents and aliens authorized to work. Accordingly, all employers and employees must complete Form I-9.

figure out how much federal income tax to withhold from an employee's paycheck. The employee fills out lines 1 through 7, indicating the number of dependents and whether you should withhold any additional federal income tax.

You get the filled-in part of the form — that is, the bottom of the first page. The employee gets the rest. Check with your state revenue department for additional requirements. Usually the federal Form W-4 is sufficient for state withholding taxes, but some states require employees to complete a state-specific form.

**New Hire Reporting Form.** The federal government has enlisted the help of employers in locating parents who owe child support. So, shortly after you hire a new employee, you must complete a New Hire Reporting Form and submit it to a designated agency in your state.

The state agency then compares the information against its child support files to locate parents. When necessary, enforcement officials can issue an income-withholding order. Your state agency also passes the information to the National Directory of New Hires, which compares it with child support information from other states. When a match is found, the information goes to enforcement officials in the other state.

You must complete and submit a New Hire Reporting Form for each new hire, whether or not he or she claims to be a parent. Each state has its own version of a

New Hire Reporting Form. These forms are usually available online.

**Required posters.** The federal government and most state governments require you to display certain posters in the workplace. These posters inform workers of their legal rights. To find out what federal posters your business needs and to get copies, go to the Poster Advisor operated by the U.S. Department of Labor. The Internet address is [www.dol.gov/elaws/asp/posters/industry.asp](http://www.dol.gov/elaws/asp/posters/industry.asp). Also, check with your state labor department to learn of any posters required in your state.

**Other paperwork.** The paperwork described so far is legally required. Here are some optional items to consider:

**Contact information.** You may want to gather contact information from your employee, such as home address, phone numbers (land line and mobile phone), e-mail address, and name and phone number of an emergency contact.

**Enrollment documents.** There may be forms or documents for the employee to complete to take part in various work-related benefits and activities, such as a healthcare plan or a retirement savings plan.

**Policy and procedures manual.** You may want to write up information and procedures to help your new employee learn the job and perform more efficiently. But don't go overboard with rigid work rules. Instead, emphasize the practical aspects of the job. ■

Fred S. Steingold practices law in Ann Arbor, Mich. He is the author of *Legal Guide for Starting and Running a Small Business* and *The Employer's Legal Handbook*.



THE LEADER IN PUMPER/CLEANER REELS SINCE 1933



## Washdown and Clean Up With Hannay Reels

### Applications

- Power washing
- High pressure washing
- Vehicle and equipment washdown and clean up

### Advantages

- Flexibility of mounted and portable designs
- Hose pickup and storage is quick and neat
- Tried and tested technology
- Tough reels for the toughest environments



Download or call for your FREE catalog  
<http://go.hannay.com/515> 877-467-3357

# BROKEN TOILET? FIX IT UP!

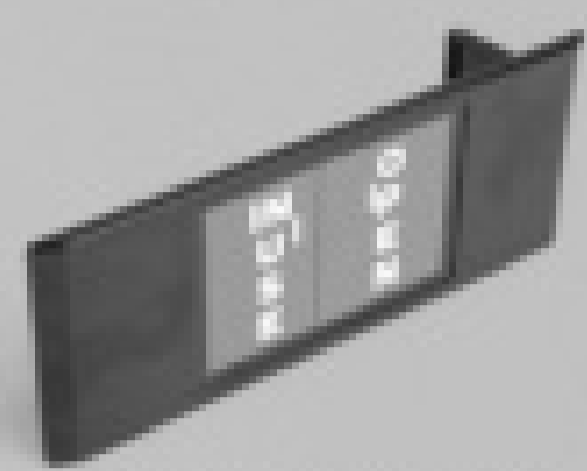

Indicator Handles

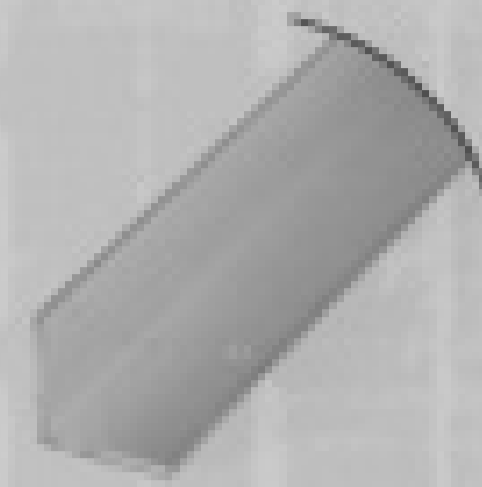

Thresholds



Skid Bases

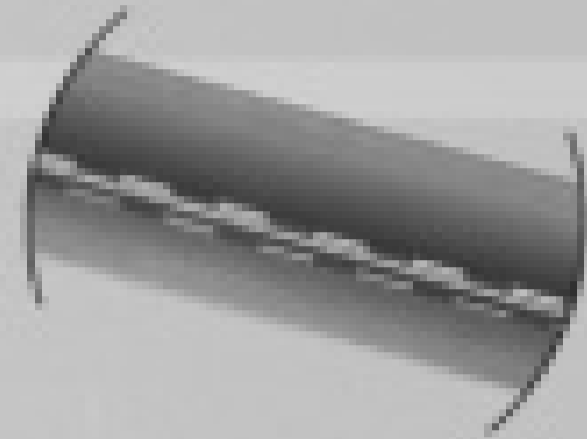

Piano Hinges

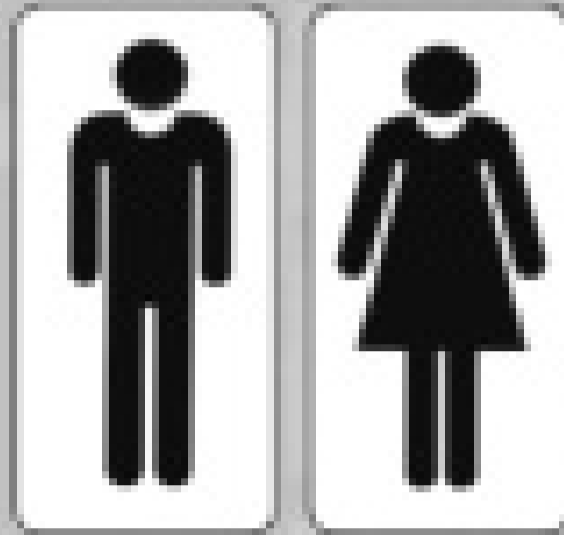

Decals and Signs



Spring and Cable Assemblies



Clips



Wind Cables



Toilet Seats



Hand and Foot Pumps



Replacement Roofs



Screws and Rivets

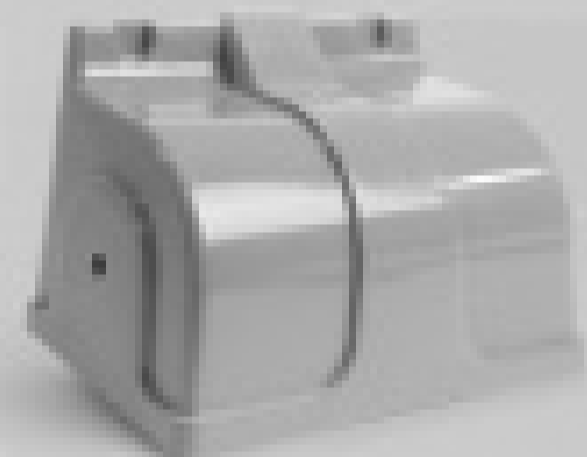

Toilet Paper Dispensers



Cam Lock Handles



Corner Moldings



Indicator Assemblies



Vent Screens



Toilet Paper Rods



Call today to order:

**1-888-935-1133**  
[www.toico.com](http://www.toico.com)





## Classy Truck of the Month

### LOCATE WITH THE BEST

**WHETHER YOU ARE JUST GETTING STARTED OR YOU ARE AN OLD PRO**, you can rely on Prototek for the best flushable transmitter and receiver systems in the industry. **FLUSH AND FIND** Locate underground nonmetallic tanks and lines with our orange AT-12 flushable transmitter and AR-1 receiver. Locate in cast iron or nonmetallic lines with our blue FT-8 flushable transmitter and FR-1 receiver. Recycle your used AT-12s or FT-8s back to us for credit toward your next purchase. Use your AR-1 for tracing metallic lines or utilities with Prototek's powerful and versatile **BuzzBox!**

Operates at 223 KHz, 3 watts max power, in 3 ranges. Ground rod and cables included.



**Prototek**



ECONOMICAL • EASY **800-541-9123**

[www.prototek.net](http://www.prototek.net) email: [prototeksales@prototek.net](mailto:prototeksales@prototek.net)

### Blocker's Septic Service Inc. Yulee, Fla.

Robert Blocker bought this 2000 Mack with a 3,600-gallon steel tank from 27th Trucks Inc. when he started his business in 2007. The truck has a 400-hp engine tied to a 10-speed Eaton-Fuller transmission, a separate 300-gallon freshwater tank and a Honda jetter. Vacuum is provided by a Masport HXL 400 pump. Inside, the truck is outfitted with AC, stereo, a CB radio, air-ride seats and Garmin GPS. Simple graphics were created by Ritter Sign & Graphics. Accents include diamond-plate toolboxes. Blocker hopes to buy a matching rig this year and a smaller truck for grease trap work.

#### Show us yours!

Got a truck with real WOW appeal? Show it off to Pumper readers — and to the whole world through [www.pumper.com](http://www.pumper.com)!

Send photos of your truck after it has been lettered with your company name, and please pose the owner(s) with the truck. Any industry-related truck is acceptable. Please limit your submission to one truck only.

Your submission must include your name, company name, mailing address, phone number, and details about the truck, including tank size, cab/chassis information, pump information, the company that built the truck, and any other details you consider important. In particular, tell us what features of the truck help make your work life more efficient and more profitable. E-mail your materials to [editor@pumper.com](mailto:editor@pumper.com) or mail to Editor, Pumper, P.O. Box 220, Three Lakes WI 54562. We look forward to hearing from you!



# Water Cannon Is A Convenient "One Stop Shop" For Pressure Washers, Engines and a Full Line of Parts & Accessories

## 27HP KOHLER Command - 3000PSI



- \*15,000 Hour Rated Belt
- \*Epoxy Powder Coated
- \*Remote 6 Gallon Tank
- \*Dual Shock Feet
- \*Low RPM Pump
- \*Twin Cylinder
- \*Rental Duty
- \*Plumbing Options Available
- \*Lifetime Frame Warranty
- \*15 Point Inspected



Part # 13H19  
TSF Series  
10.8GPM  
**\$4,129**



Part # 13H16  
660 Series  
10 GPM  
**\$5,799**

## 20HP GX 620 HONDA - 3000PSI

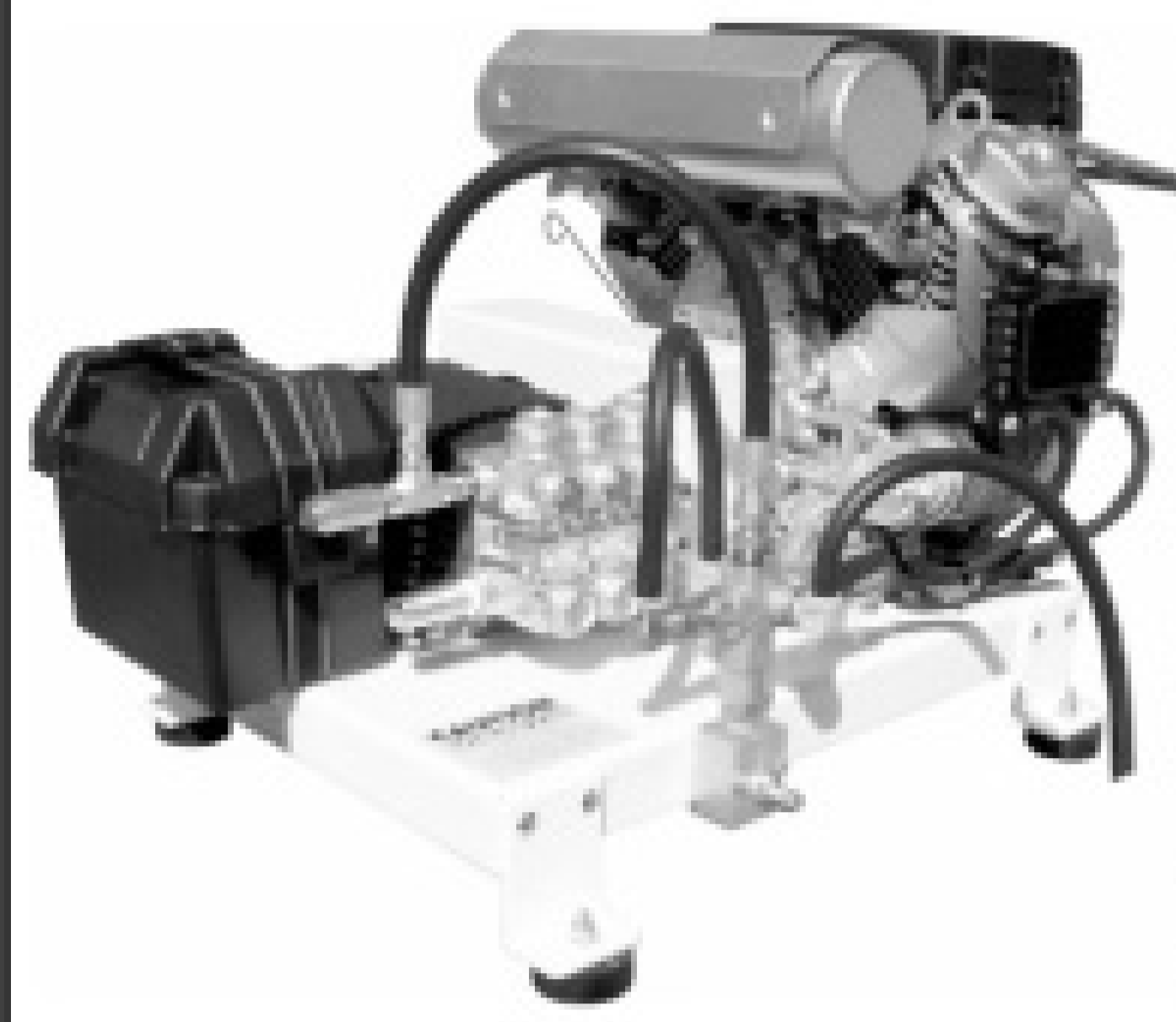

- \*Industrial Features
- \*Low RPM Pump
- \*Electric / Key Start
- \*Adjustable Throttle
- \*Lifetime Frame Warranty
- \*Tank Feed Inlet
- \*We Customize
- \*Overheat Protection
- \*Jetter Versions Available
- \*Specify Skid Mounted



Part # 13H13  
TSF Series  
8 GPM  
**\$2,999**

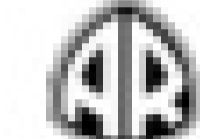

Part # 13H10  
XW Series  
8 GPM  
**\$3,049**



Mosmatic 21" & 30" Stainless Steel Surface Cleaners  
Include A Spot Spray Wand & are Rated To:  
250F. Deg @ 4500PSI Max.  
See Online demo: [www.watercannon.com](http://www.watercannon.com)

# 1-800-786-9274

Shop Online  
[www.watercannon.com](http://www.watercannon.com)  
or Call for Fast, Friendly Service

## 27HP & 30HP KOHLER Command V-Twin - High GPM



- \*15,000 Hour Rated Belt
- \*Epoxy Powder Coated
- \*Remote 6 Gallon Tank
- \*15 Point Inspected
- \*Industrial Features
- \*Low RPM Pump
- \*Electric / Key Start

- \*Specify Skid or Wheels
- \*Tank Feed Inlet
- \*We Customize
- \*Jetter Versions Available
- \*Well Balanced - Low Vibration
- \*Plumbing Options Available
- \*Lifetime Frame Warranty



Part #13K08  
TSF Series  
12GPM @ 2800PSI  
**\$4,559**



Part #13K05  
1530 Series  
15GPM @ 2000PSI  
**\$6,199**

## 24HP GX 670 HONDA Twin Cylinder - High GPM - 3500PSI

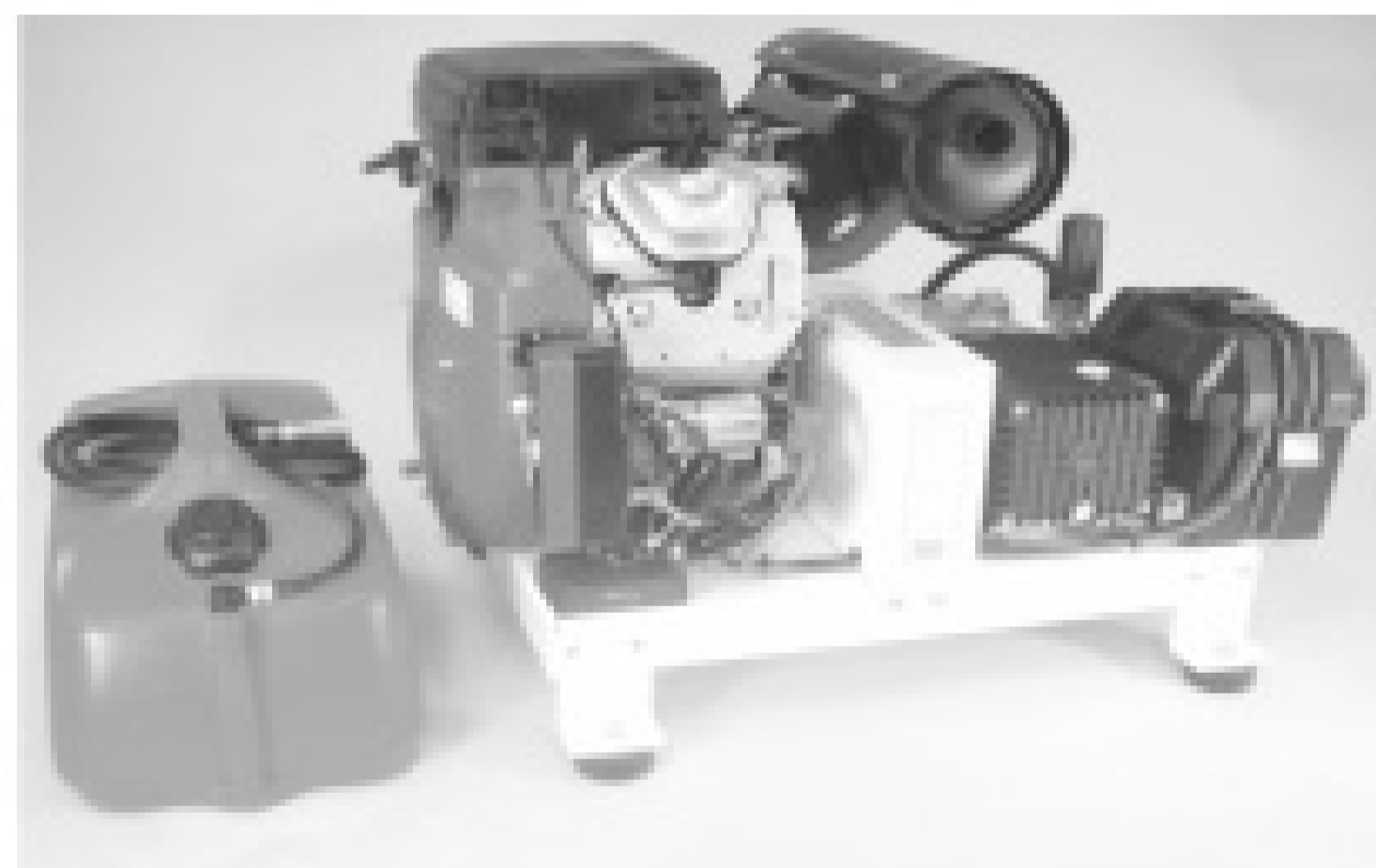

- \*Low RPM Pump
- \*Twin Cylinder
- \*Rental Duty
- \*Plumbing Options Available
- \*Lifetime Frame Warranty
- \*Adjustable Throttle
- \*Overheat Protection
- \*Well Balanced - Low Vibration

- \*Epoxy Powder Coated
- \*Industrial Features
- \*Electric / Key Start
- \*Specify Skid or Wheels
- \*Tank Feed Inlet
- \*We Customize
- \*Jetter Versions Available
- \*Remote 6 Gallon Tank



Part #13H39  
TSF Series  
8GPM @ 3500PSI  
**\$3,249**



Part #13H37  
XW Series  
8GPM @ 3500PSI  
**\$3,299**

### 50' Super Kit



Includes: Chemical/Soap Injector  
& 5 Color Nozzles

Part # 11564 **\$64**  
Up To 4000PSI

Part # 11584 **\$84**  
Up To 5000PSI

### 100' Deluxe Kit



Includes: Chemical/Soap Injector  
& 5 Color Nozzles

Part # 11109 **\$109**  
Up To 4000PSI

Part # 11114 **\$149**  
Up To 5000PSI

### Imagine The Possibilities



**1-800-454-9274**

### Whisper Wash



24" Part # 16715 **\$699**  
28" Part # 15698 **\$729**  
36" Part # 16865 **\$889**

### New XD Series Up to 7000PSI



# Mr. Smith Takes the Wheel

**Harold Smith developed the Five Keys of Space Cushion Driving, then dedicated his life to preaching collision avoidance**

**P**umpers maneuvering the streets with a heavy liquid load and a high center of gravity stand to learn life-saving safety lessons from Harold Smith's teachings. And gearing up for the 2009 busy season, it's a good time for a refresher course based on tips from the safety guru behind the Smith System Driver Improvement Institute.

Jim Smith (no relation to Harold) trained under the founder of Dallas-based Smith System and currently serves as the safety training company's vice president of training.

Harold Smith served in the military during World War II. When he came home to Detroit, Smith started a driver training school, where he soon developed the Five Keys of Space Cushion Driving. While these rules of the road will sound familiar to today's drivers, Smith was the first person to put the safety tips down on paper, according to Jim Smith.

Harold Smith died in the 1980s. His company — now a holding of Transportation Resource Partners, whose managing director is legendary racer and team owner Roger Penske — has trained several generations of professional drivers on the finer points of collision avoidance. The approximately 110 Smith System trainers work with fleet trucking companies and independent drivers across many industries.

## Pumper Interview

By Jim Kneiszel

**Pumper:** How did Harold Smith's safety training take off?

**Smith:** He found a fleet company in Detroit that was having a rash of collisions and offered to teach its drivers his program. If the drivers improved, they could pay him, if they didn't learn anything, they didn't have to pay. Ford Motor Co. heard of his success and hired him in 1952 to go out and train fleet buyers "how to keep the shiny side up and the rubber side down." Then Ford gave him the company's 50 millionth car off the assembly line and sent him on a cross-country safety tour.

**Pumper:** Can you elaborate on Smith's Five Keys of Space Cushion Driving?

**Smith:** Aim high in steering means to look farther ahead than you would normally look. For thousands of years, humans walked through our environment and eyesight was formed for that purpose. In the last 100 years, the automobile has changed the speed we travel. But nobody's really put any effort into helping us establish a new set of habits for our new speed. You should be looking 15 seconds ahead, a block in city driving and a quarter mile on the highway.

**Get the big picture.** We talk about your seeing distance, and we say you should allow 4 seconds of following space from the vehicle in front of you. And you need to build a 360-degree circle of awareness by checking your mirrors every five to eight seconds. That means a balanced check; you don't need to check all the mirrors over that time, but one time look to the right mirror, then the center, then the left. There might be times when it's more important to check one of them frequently, or all of them.

**Keep your eyes moving.** Never focus on the same thing for more than two seconds. We talk about the different types of vision, peripheral and



**ALL THE MOVES YOU MAKE WITH A HEAVY LIQUID LOAD ARE MOVES YOU WANT TO MAKE GRADUALLY AND EARLY, INCLUDING ADJUSTING SPEED AND DIRECTION. WHEN YOU SEE SKID MARKS ON A HIGHWAY CLOVERLEAF, THE PROBLEM IS A LOAD WANTED TO KEEP GOING WHEN THE DRIVER WANTED TO TURN UP THE ROAD.**

Jim Smith

central. Peripheral vision is about 180 degrees of fuzzy vision. Central vision is three degrees of clear sharp vision used to gather information and detail. The problems come when you have a fixed stare, and you lock the central vision on one thing for two seconds or more and your eyes are no longer moving. Lock it in too long and you start to lose the edge of your peripheral vision. Another problem is the blank stare, when you're using nothing but peripheral vision. You're picking up the light, color and motion, but not the detail. You're looking, but not seeing, and then you become vulnerable.

**Leave yourself an out.** Harold Smith said if you surround yourself with space instead of vehicles, it will be hard for you to have an accident. If other drivers can't get close to you, they can't hurt you, and if you screw up there's no one there to hit you. The only space you have a chance of controlling is in front of you. You can't control the space behind you and you may have the sides blocked.

If you sit in a parking lot and watch traffic for 10 seconds, you'll see traffic travels in clusters. We're comfortable in clusters; we tribe up. It's an unconscious thing. But we don't want drivers to travel in the pack. We don't want to be where people are, but where people aren't. Try to put yourself between those clusters.

**Make sure they see you.** You want to be proactive rather than reactive to keep that driver making an idiot move from forcing you to adjust at the last second. I try to encourage people to run with their lights on and make themselves as visible as possible. Look for eye contact with other drivers. If I don't see somebody looking my way, I assume they may pull out in front of me. I might have to tap on my horn to keep them from making a move that will cause a collision.

**Pumper:** About gadgets and gizmos in trucks, you once wrote, "There is no shortcut in trying to improve safety performance." What did you mean?

**Smith:** It's amazing how much money we spend making vehicles safer in crashes, but how little time we spend teaching drivers how to avoid them. We have crumple zones, anti-lock brakes, electronic stabilization and lots of other things working for us, but we're spending little time on the other side of the issue. We still need to do the basic things to keep us safe and sane behind the wheel. There are a number of technologies evolving, and I believe as they become more refined, they will eventually help drivers ... but even if we can eventually count 100 percent on the electronic inputs we receive, it's only going to give us some protection, not complete protection.

**Pumper:** Part of what you promote is breaking poor driving habits. What driver factor is causing the most problems these days?



**Smith:** News attention now is focused on driver distraction, everything from cell phones to radios to conversation. I can't even text when I'm sitting still, let alone going down the road. And one of the most dangerous things is dropping food and drinks. Sometimes we have a tendency to reach down for something, and it's never a good outlook when you get your head below the dashboard.

**Pumper:** Why should pumping companies make further driver training a priority?

**Smith:** If there's ever a contractor who should practice aiming high in steering and seeing the big picture, this is it. All the moves you make with a heavy liquid load are moves you want to make gradually and early, including adjusting speed and direction. When you see skid marks on a highway cloverleaf, the problem is a load wanted to keep going when the driver wanted to turn up the road.

**Pumper:** How can small liquid waste companies or individual drivers best utilize the Smith System training?

**Smith:** There are two ways. The first is taking the online training, which gives them the basics of the five keys and testing to check comprehension. Or they can take the one-day Driver Direct training, which gives them the behind-the-wheel lab work. Driver Direct includes two hours of classroom work and the rest is behind-the-wheel, typically with four or five students taking turns driving and an instructor teaching the Smith System methods. The real learning happens behind the wheel.

*Jim Smith is vice president of training for Dallas-based Smith System Driver Improvement Institute. To contact him or learn more about the driver training programs, go to [www.smith-system.com](http://www.smith-system.com). ■*



**Our All Natural Products EXCEED the Green Seal Standards to Better Protect Our Environment**

ONE STOP SHOPPING!  
Offering a Complete Line of  
All Natural Portable Toilet & Septic Needs

**Complete Line of Paper Products  
Portable Toilet Chemicals including:  
Eliminator Nano Emulsifier Deodorizer  
Nev-R-Freeze—Portable Toilet Anti-Freeze  
All Purpose Degreaser  
Graffiti Remover  
Hand Sanitizers  
Urinal Blocks**

*Servicing the Industry with Pride Since 1994*  
250 Old Marlton Pike • Medford, New Jersey 08055  
800-699-9903 • Fax: 609-714-3030 • [www.delvel.com](http://www.delvel.com)



**KNOW-HOW TO GET YOU MOVING**

Now In **STOCK!**



2007 Sterling 4400 aluminum tank, NVE 506 pump, PTO jetter 10 GPM, 3,000 PSI, 150 gallon water tanks 66,000 GVW, 410 HP, 10 spd.

**Call for price**



2007 Sterling 2,500 gallon steel Jurup pump, Mercedes 260 HP, 10 spd., engine brake, traction control, ALUMINUM HOSE TRAYS.

**Call for price**

*We Have Financing Available!*

Call Us Today Toll-Free:  
**888-201-9166**

[www.badgertruck.com](http://www.badgertruck.com)

**WHO OFFERS MORE?**

- Great Low Prices on Quality Equipment
- FREE Delivery in the Lower 48 States on New Sterlings
- 5 Year Engine Warranty on new Sterlings (Mileage allowances vary by model)
- Delayed Payment Start (to approved credit)

Septic - Portable Toilet - Hoisted Vacuum - Slide-Ins  
**New Units Available / Trade-ins Accepted!**  
Financing & Lease Plans



**NEED IT? RENT IT!**



- Air Machines
- Liquid Vacs
- Liquid Rings
- Roll-Offs
- 130 Bbls
- Cyclones
- Combos

**YOU MIGHT AS WELL RENT THE BEST.**

**NEED IT? RENT IT!**

**1-888-955-2087**

Mississippi • Louisiana • Texas • South Carolina  
[www.vactruckrental.com](http://www.vactruckrental.com)



# Pumper

see photos in COLOR at [www.pumper.com](http://www.pumper.com)

# TRUCK STOP



April



**05 HV56 Gap Vax Hydroexcavator:** 5300 CFM 27' HG blower, 6 cyclone wet-dry vac, telescoping boom, 1200 gal. water tank, 15 cubic yd. debris tank, wireless remote.

713-783-3363

P4



**1995 Mack CH613:** E7, 350, spl. 10, 4500 gal., full DOT door, 300 water, jetter 12 gpm, 2,000 psi, 700 cfm, Demag, full tire tread.

727-576-1111

P4



**1995 Ford F-Series Septic Truck:** 429 gas fuel injected, 1650 gallon tank and pump only 18 months old.

410-472-2723

P4



**1995 International:** 4000 gallon S/S Progress tank, 1500 rpm Wittig pump.

\$45,000

956-726-9999

P4



**1995 Ford L-8000, Vac-Con V-350:** 8.3 Cummins 275 H.P., John Deere diesel upper, 600' 1" hose, telescopic boom, 3-stage blower, well maintained municipal truck.

\$29,900

814-696-4343 - Hollidaysburg, PA

CMP4



**1999 Mack CH613:** E7, 427, 13 spd., 4500 gal., full DOT door, 300 water, jetter 12 gpm, 2,000 psi, 700 cfm, Demag, full tire tread.

727-576-1111

P4



**Purchased New 05/2007 Pre-Emission Kenworth T-800:** C15 475 Acert. 475 hp, Fuller 10-spd., Concept 2000/5300 gal. alum. tank, 2 compartments. (5000 waste/ 300 fresh), 3 full-size anti-surge internal baffles. Jetter sys. w/300' hose

\$160,000

570-881-2775

P4



**2000 IHC 5600:** N-14 Cummins, 475 hp, low 300s, 20 front, 46 rear air, 3500 gal., full tilt/opening, DOT 407/412. P.O.R.

936-825-2000

P4



**1999 IHC 2674, Vac-Con VPD-3116:** ISM Cummins 400 H.P., Allison auto., 46 rears, 824 Roots blower, municipal truck.

\$59,900

814-696-4343 - Hollidaysburg, PA

CMP4



**4000 Gal. Vacuum Truck:** 1996 Volvo, 4000 gal. IbeX vacuum tank, VED-7 Volvo 260 HP diesel, Allison auto, 46,000 rears, 18,000 front. Just released by major electric utility co., only 9,350 miles since new.

\$29,900

814-696-4343 - Hollidaysburg, PA

P4



**1986 Chevy C65 Cat:** Diesel 175K, 5-speed manual split shift. New brakes and tires. Pump-Meyers D-65, 2000 lbs @ 65 GPM. One hour on rebuild. Perkins diesel. 1000 gallon tank. Good hoses and nozzles. Ready to work.

\$10,000 OBO

Will also accept trade for a trailer jett of equal or less value.

770-527-0376

ICPBM



**1999 Chevy 3500 Heavy Duty:** 454, 5-spd., A/C, 180K miles, 1,000 gal tank, Masport M4 pump, 5.5 hp Honda.

\$11,500

214-289-3864

PS



**2004 CH613 Macks:** Set forward axle, 427 engine, 10-spd. 420-440 miles, double frame, dual exhaust, 3000 gal., full tilt/opening, DOT 407/412. In progress. P.O.R.

936-825-2000

P4



**Portable Toilet Truck 2000 F650:** 6-spd., A/C, AM/FM, new carbon/steel tank, 700 waste, 250 fresh, Masport, demand wash-down pump, alum. boxes, HD hitch, 2-unit carrier.

\$27,000

Contact Cliff 812-332-9999

P4



**1991 Volvo/White:** 6570 miles, 315 Cummins, Gap Vax 27 pd, Hibon 5000 cfm blower, new debris body late 1998, pressure dump, 3177 hrs.

\$38,000 OBO

618-527-5846

P4



**LAUNDRY TRAILER:** 2003 48' gooseneck, 12 washers, 12 dryers, all 2009 electronic coin-op Maytags. Can deliver.

\$43,500

VPS2000@msn.com, 920-655-7065

PS

# Pumper

see photos in COLOR at [www.pumper.com](http://www.pumper.com)

# TRUCK STOP



April



**2000 Sterling:** C-12 Cat 8LL, 3250, full opening rear door, hoist unit, Challenger 460 pump, jetter unit, stainless hose trays, stainless heated valves.....\$51,500  
**607-769-0172**

P4



**1997 Vac-Con Model V390THA:** 71,000 miles, 8-spd. trans., 65 gpm, 2000 psi pump, 3-stage fan, hydrostatic drive, extendible boom, 600' of new jet hose, new white paint. ....\$57,500  
**Craig 714-639-8352**

CPBM



**2000 Pearpoint Pipeline Video Inspection:** Color camera P494 pan/tilt, P599 drum, 1000', P420 tractor, recorder, P377 controller, 110V gen., fully self-contained, refurbished by Pearpoint, ex-city. \$34,500  
**Phil 562-926-5015 or 562-824-1093**

CM/P4



**2003 IHC 9200:** C-15 Cat, 475 hp, Jake brakes, 18-spd., 349 miles, 3000 gal., full tilt/opening, DOT 407/412. P.O.R.  
**936-825-2000**

P4



**2006 Safevacs - Five (5) To Choose From:** Sterling LT9511 chassis, MBE 460 engines, 27" Wispair blowers, OMSI transfer cases. ....Special Price \$149,950 Each  
**Call 1-888-739-0838**

P4



**1994 Ford L9000:** 33000# GVW, Cummins L10, 260 hp, 8-spd., air brakes, 2004 2500 gal. septic unit, 3" intake/6" discharge, 200 cfm Masport vacuum/pressure pump. ....\$24,990  
**Call Judge Coleman 516-398-5638**  
**Email: [cwjudge@aol.com](mailto:cwjudge@aol.com)**

P4



**2005 Crescent Tank Isuzu Truck:** 650 waste, 350 fresh, carry 6 units, Masport pump & new Masport traps; NQR diesel, auto., 91,653 miles. Factory refurbished vacuum tank, good condition.....\$35,000  
**585-657-4104**

P4



**2008 Dodge Diesel 5500:** Only 150 miles, 19,500 GVW, new tank, Conde pump, pot-tie rack, LED lights, never used. (My loss, your gain.) .....\$59,999  
**Sandy 928-643-7625**  
**or 435-689-9795**

P5



**1998 International 8100:** 2500 gal., jetter/pressure washer combo, 9-spd., 350 hp Cummins, 2-yr-old Jurop R260 pump. Very strong truck. ....\$38,000 OBO  
**678-873-7934**

P4



**2005 Ford F550 Super Duty Diesel Pump Truck:** White with gray interior, Best built with a 1050 gallon stainless steel tank, PTO driven Masport pump, 75,000 miles. Perfectly maintained by Gabrielli Ford in Jamaica, NY. ..Wholesale Price of \$27,500  
**800-634-2085**

P4



**2001 Sterling:** 3126 Cat engine, 6-spd., AC, cruise, new 2500 gal. tank and Jurop R260 vac pump, all new paint and accessories. Financing available. ....\$39,000  
**877-898-5104**  
**[hullstruckbodies.com](http://hullstruckbodies.com)**

P4



**Shower and Restroom Trailers:** Platinum and Gold Series, new and used available. Each with separate men and women sides.  
**CCI/Brian Touey 805-896-3777**

PBM



**1995 Ford Aeromax 9000:** N-14 Cummins, 350 hp, 52K GVW, 10-spd., 150K miles, 3600 gal. tank, Wittig Demag pump, 3 heated valves, 2 alum. tool boxes, truck runs daily, custom built in 2004 by Andert Inc. Must sell! New truck ordered. ....\$50,000  
**203-879-3746 CT**

P4



**2001 Sterling LT9500:** Standard cab, Cat C12 engine, 410 hp, 187,132 miles, 8LL trans, Jake, TufTrac susp., 20,000 front, 46,000 rear, 274" wheelbase, double frame. Call for more info. (Stk #2818)  
**DeBauche Truck & Diesel (Wis.)**  
**Ray Buchmann: 800-458-2891**

P4



**2003 Kenworth:** C-12 Cat, 445 hp, 13-spd., heavy specs, Jake, AC, cruise, new 3300 gal. tank & Jurop R260 vac pump, new paint & tires Financing available...\$69,000  
**877-898-5104**  
**[hullstruckbodies.com](http://hullstruckbodies.com)**

P4



**1993 International 4900 DT 466:** 250 hp, 33,000 GVW, 6+1 trans, new motor 80,000 miles, 2,350 gallon tank, Jurop R260 pump, cab repainted, new tires. Great starter truck. ....\$35,000  
**770-898-3761 - Georgia**

P5

# Pumper

see photos in COLOR at [www.pumper.com](http://www.pumper.com)

# TRUCK STOP



April



**1999 Vac-Con Jet:** Mounted on 2000 Intl. Navistar chassis. 1600 gal. poly tank, articulating reel w/500' of 1" hose, FMC water pump, 60 gpm @ 2000 psi. Low hrs: 1,166 & low miles: 11,349...\$39,500 OBO  
**757-464-2934** P4CS



**2002 Freightliner FL80:** 3,800 gal. tandem, Cat 250 HP, 9-spd Eaton Fuller, 156,649 miles, 11x22.5 tires, 26#F-58#R Transway TSI-800 pump, 2-4" & 1-6" valves, jetter system.....\$53,900  
**chrisdunn@lapinservices.com**  
**for pics/questions, Ph: 321-436-0150** P4



**2001 Ford F-550:** Powerstroke diesel, A/T, AC, 136,000, runs great. Best 600w/300f, high pressure wash. ....\$26,500 OBO  
**816-537-5623 Warren** P4



**2004 Crescent Tank Chevy Truck:** 650 waste, 250 fresh, carry 6 units, Masport pump & new Masport traps; diesel, auto., 111,710 miles. Factory refurbished vacuum tank, good condition. ....\$39,000  
**585-657-4104** P4



**Used Model 747-4000 Sniper Jet:** 18 gpm @ 4000 psi, only 32 hours on machine. Selling to buy new vac tank.  
.....\$15,000 OBO  
**Call Dave 732-244-0189** P4CS



**2002 Mack:** CX, E7 427 w/Jake, 10-spd., new 4000 gal. US tank, Jurop LC420, new tires w/alum. rims. Must see. ....\$71,000  
**www.nationaltruckcenter.com**  
**Office: 305-691-8407**  
**Israel Vera: 305-525-6406**  
**George Gonzalez: 954-558-0816** P4



**2005 Mack:** CX Vision, E7 330, 10-spd., double frame, 20,000# front springs, new 4000 gal. US tank, Jurop LC420. Full warranty. ....\$76,500  
**www.nationaltruckcenter.com**  
**Office: 305-691-8407**  
**Israel Vera: 305-525-6406**  
**George Gonzalez: 954-558-0816** P4



**2006 Peterbilt 335:** 300 Cat, 10-spd., 2000 gal. Imperial tank (1500 waste/500 fresh), 3" inlet, 2 side service, only 5K miles! New truck! ....Asking \$71,900 OBO  
**815-970-7253** P4



**2000 International 4700:** 192K, 1 owner, 25,500 GVW, 900/300/150, boom, chemical pump hose, \$25,500. Also 2000 Intl. 4700, 230K, \$25,500; and 1998 Intl. 4700 low pro, 205K, \$22,500.  
**256-757-9900** P4



**2002 International 2600 Series:** C12, 385 hp cat eng., air, Jake, 20F, 46RR, full lock, 18-spd, trailer 50-ton equipment, 202,000 Km, Transway 800 system, 3600 gal., 2 inlet 4", 1 outlet 6", 36" back door, 24" man hole. ....Asking \$66,000 US  
**Mario 613-487-3483 (Canada)** P4



**1987 Auto Car L10 Cummins:** Engine, head, and radiator rebuilt Sept. 2006. Steel 4000 gallon tank with a 1-year-old Battioni 220 cfm pump.  
**Call 717-629-1597 or 717-738-2149** P4



**1994 Chevy Kodiak Vac Truck:** Cat 3116 @ 250 hp, 8LL, 4,000 gal. tank with National Vac unit, 16K/40K axles, 237K miles, 22.5 tires, new paint. ....\$24,500  
**715-546-2680** PBM



**4K Gal. Vacuum Septic Steel Tank:** 2 baffles, Transway, primary, secondary, ladder, 24" manway & rear hatch, hose trays, sight tube, 6" dump, 4" load, 3 pres. reliefs. ....\$12,900  
**321-436-0150**  
**chrisdunn@lapinservices.com** P4



**2000 IHC 5600:** N-14 Cummins, 475 hp, low 300s, 20 front, 46 rear air, 4,000 gal.  
**936-825-2000** P4



**2001 International 4700:** 150K, 1 owner, 25,500 GVW, air brakes, 900/300/150 tank, hose boom, chemical pump hose on wand, \$32,500. Also 100 used portable restrooms, \$125-\$250 ea.  
**256-757-9900** P4



**2003 International:** 9200 Cat, 410 hp w/Jake, 10-spd., new 4800 gal. US tank, Jurop LC420, 20,000# lift axle, new tires w/alum. rims. Must see. ....\$82,500  
**www.nationaltruckcenter.com**  
**Office: 305-691-8407**  
**Israel Vera: 305-525-6406**  
**George Gonzalez: 954-558-0816** P4

# Pumper

see photos in COLOR at [www.pumper.com](http://www.pumper.com)

# TRUCK STOP



April



**1997 International 9400:** Detroit 60 series, 430 hp, 3200 gal., full tilt, full open rear door, non code.  
**936-825-2000**



**1988 Vac-Con V390T Ford LN8000:** New Cummins BT4 diesel pony engine (less than 50 hrs.). Both pony and main engine work great. Great for parts...\$15,000 OBO  
**727-392-1352**



**2000 Sterling 9513:** 4150 gallon aluminum tank. 20,000 front, 40,000 full locking rears. C12 Cat, NVE pump. Heated 4 and 6 inch valves. Using daily...\$41,500  
**715-234-6325**

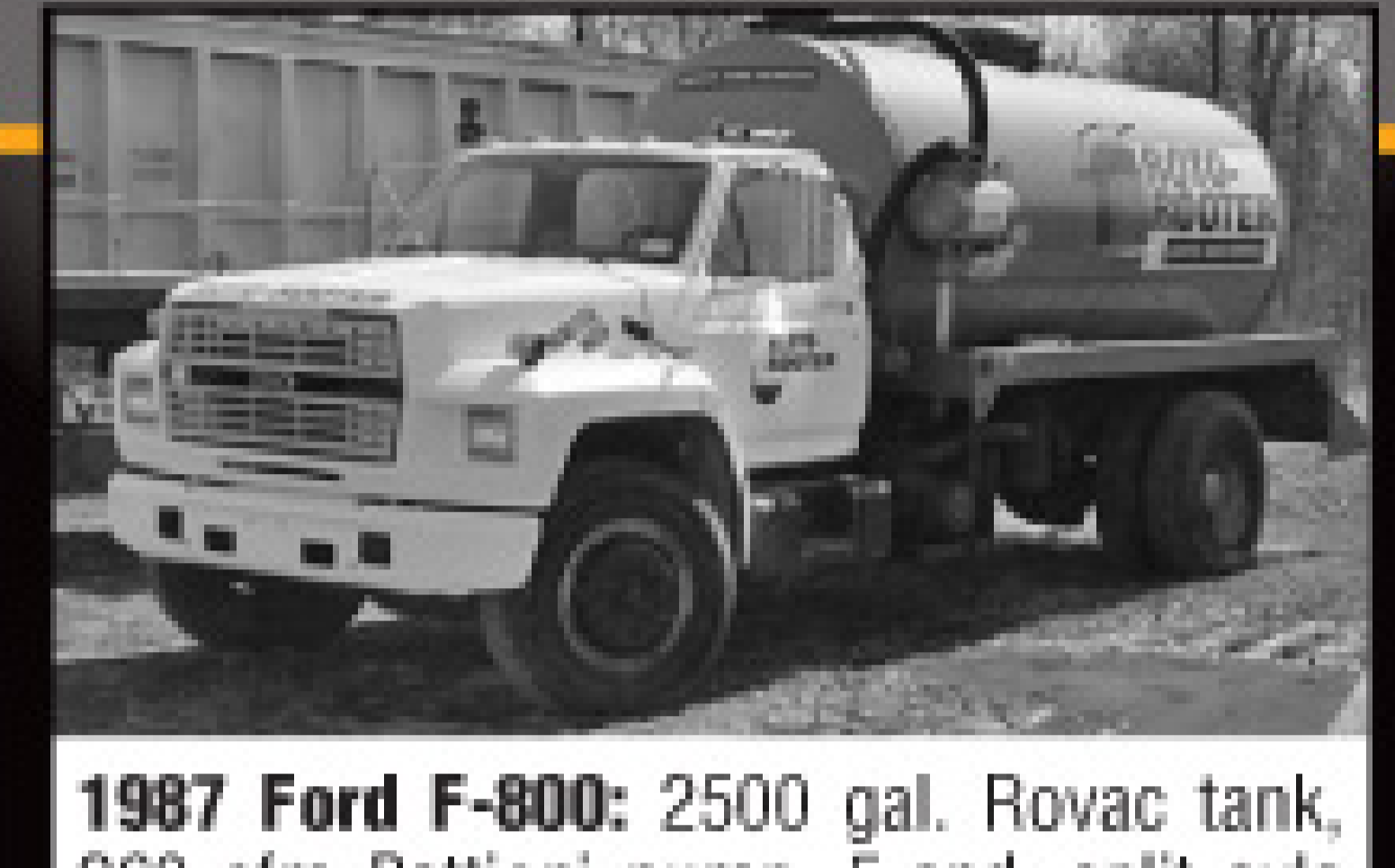

**1987 Ford F-800:** 2500 gal. Rovac tank, 260 cfm Battioni pump, 5-spd. split axle transmission. Truck in good condition and ready to work.....\$6,500  
**800-252-3012**  
**ned.enviroventure@gmail.com**



**Porta Potty Pumper Trailer:** Holds 2 toilets, 125 gal. fresh water, 250 gal. waste, vacuum pump ran by a 4.5 hp Honda, built in 2006, storage box for supplies.  
 .....\$6,500 OBO  
**715-569-3868**



**1988 Ford L8000:** 3800 gal., 350 cfm Jurop vac pump, 40K miles on engine, 9-spd. trans., new brakes, new paint. All works well. ....\$25,000 OBO  
**Dave Fore: dfore24@msn.com**  
**574-215-5848 or 574-848-7704**



**2000 Sterling:** C-12 Cat, 10-spd., AC, cruise, new 2500 gal. tank and Jurop R260 vac pump, new paint and tires. Financing available. ....\$39,500  
**877-898-5104**  
**hullstruckbodies.com**



**2000 GMC 3500 Heavy Duty:** 454, auto, A/C, 108K miles, 1,000 gallon tank, Masport M4 pump. Very Clean inside & out. ....\$13,500  
**214-289-3864**



**1991 White-Volvo with 1995 Keith Huber Berringer II:** 1600 cfm, 3300 gal. tank, good condition, ready to work. Regular PMs. Great looking truck. ....\$93,000 OBO  
**214-391-1109**

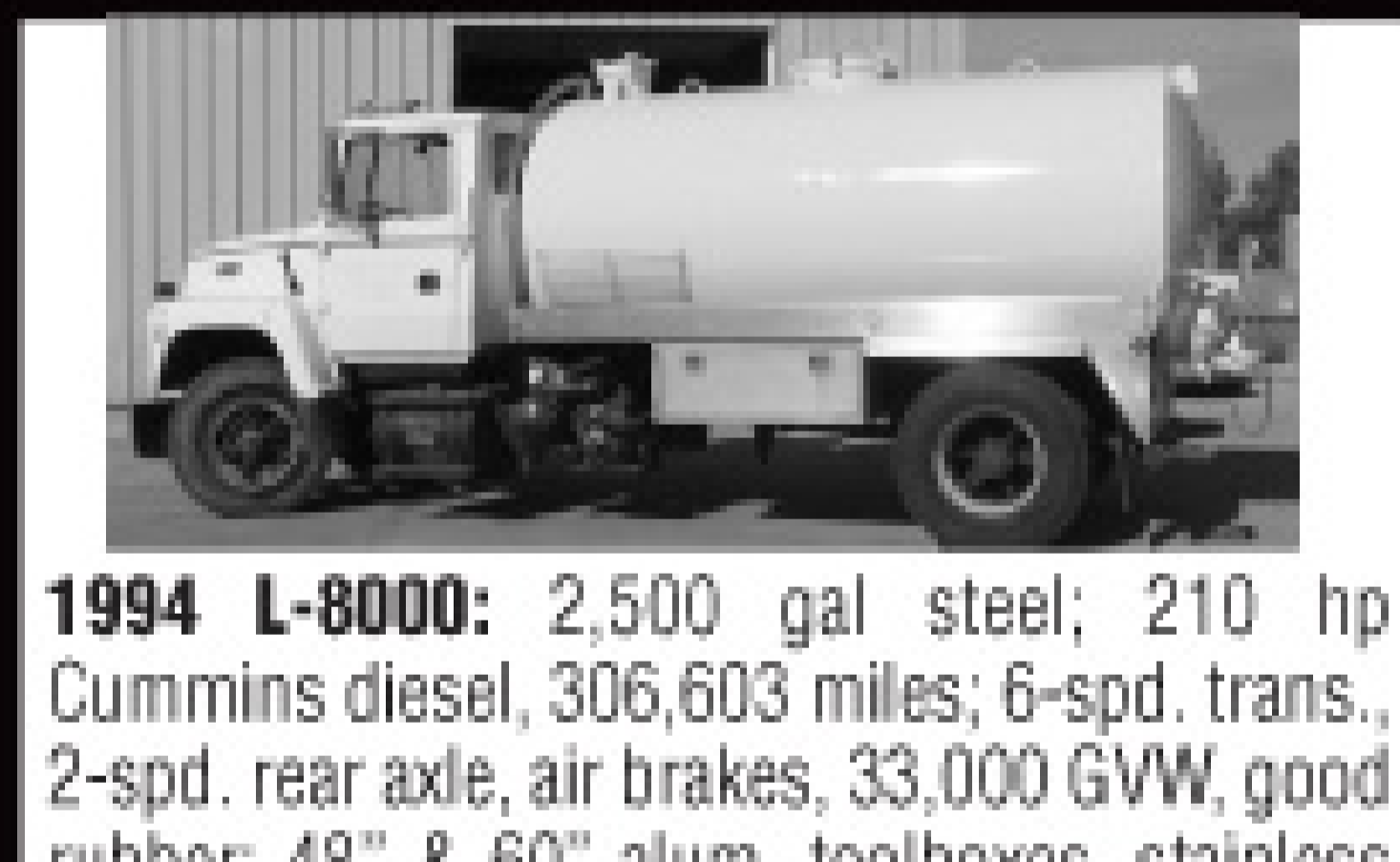

**1994 L-8000:** 2,500 gal steel; 210 hp Cummins diesel, 306,603 miles; 6-spd. trans., 2-spd. rear axle, air brakes, 33,000 GVW, good rubber; 48" & 60" alum. toolboxes, stainless catwalks, 4" front/rear intakes, 6" discharge, brand new Masport H15W water-cooled (10 hrs); reliable truck, one owner. ....\$19,500  
**Tim 513-755-8050**  
**mikeullman@winelco.com**



**1996 GMC:** 3116 Cat, 215 hp, auto, A/C, air brakes, 32,000 GVW. 172,000 miles. 2000 gal. steel vacuum tank with new Masport HXL75 pump. Truck built 11/07.  
 .....\$25,000 OBO  
**928-342-0164**



**2004 Mitsubishi Fuso:** 4 cyl. diesel., 120K miles, 950 waste, 400 fresh, Best stainless vac unit, 19,800 GVW, hyd. drive, Masport pump, pressure washer capabilities, toilet carrier. ....\$22,000 OBO  
**Arcade Pumping 888-525-7229**



**2004 Mitsubishi Fuso:** 4 cyl. diesel., 120K miles, 950 waste, 400 fresh, Best stainless vac unit, 19,800 GVW, hyd. drive, Masport pump, pressure washer capabilities, toilet carrier. New upgrades.....\$32,500 OBO  
**Arcade Pumping 888-525-7229**



**Tractor Pkg. Deal:** '04 International 9100 day cab, ISX-425 Cummins engine, Jake, 10-spd., 12 fr, 40 rr, air suspension, 07 Vacutrux trailer, 40' chassis, 7800 gal. vacuum tank, 1054LNHRVPI dual cooled pump with a 4 cyl. Perkins diesel, air suspension. ....Asking \$116,000 US  
**Mario 613-487-3483 (Canada)**



**2003 Sterling:** C-12 Cat, 10-spd., AC, cruise, new 3500 gal. tank and Jurop R260 vac pump, new paint and tires. Financing available. ....\$59,500  
**877-898-5104**  
**hullstruckbodies.com**

**THIS SPACE CAN BE YOURS!**

Just go to  
[www.pumper.com](http://www.pumper.com)  
 or [www.pumpertrader.com](http://www.pumpertrader.com)  
 and fill in the online form.

# Marketplace Advertising

**CONFINED SPACE ENTRY PACKAGE**  
ONLY \$2,995

The best package on the market includes:

- 4-Gas Air Monitor (3 Year Sensor Warranty)
- 7' Tripod
- 3-Way Fall Protection
- Work Winch
- Full Body Harness

Add a Blower with 15' of duct for only \$300!  
Add a 5 Minute Escape Respirator for only \$500.

**Ask About Our**

- Harben Jettors
- GapVax Combination Trucks
- Vac Replacement Parts
- Camera Systems
- Nozzles & Hoses
- Blowers & Ventilators
- Magnetic Lid Lifters
- Aluminum Folding Ladders
- Repairs & Service

**MTECH** 800.362.0240  
www.mtechcompany.com

Simple Solutions  
DISTRIBUTING LLC  
MAKERS OF  
**Wolverine Brand™**  
DOOR CONTROL PRODUCTS

**\$40 ea**  
Case Qty 6  
**Free Shipping**  
lower 48

**Wolverine Brand Vent Filters**  
**Stop The Stink-GUARANTEED!**

In New Jersey  
**973-846-7817**  
Outside New Jersey  
**866-667-8465**

www.IndustrialOdorControl.com  
www.StopSepticOdor.com

PayPal VISA M.C.

Major Credit Cards Accepted!

**\$35 PER DOZEN** **\$189 FOR 6 DOZEN**

- 14" Gauntlet
- Plastic Coated
- Jersey Liner
- Sandpaper Finish Grip
- 1 Size Fits All

Make checks payable to ADVANCE GLOVE CO.  
Please include UPS shipping address.

**ADVANCE GLOVE & SAFETY CO.**  
3630 PICNICK DR. • FLINT, MI 48930  
TEL: 810.232.1223

**Sewer Camera**

**\$1,095**  
Free Freight

**Drain Snake**

**\$329**  
Free Freight

**Jetter Package**

**4.0 GPM 4000 PSI**

**\$1,499**  
Free Freight

**COMPLETE DETAILS AT**  
www.AmazingMachinery.com  
**1-800-504-7435**

**Mobile Dewatering Service**

Municipal & Industrial Sludge Digesters, Lagoons, Ponds, etc.

- Double Belt Filter Press
- Up to 25% Drier Cake
- Professionally Staffed
- US & Canada

**Fluid Technology, Inc.**  
P.O. Box 937, Oxford, OH 45056  
Phone: 513-981-7808  
E-mail: sales@fluidtechinc.net  
Web site: www.fluidtechinc.net

**Waterblaster Rentals**

Houston, Texas

**Boatman Industries**

1K to 50K psi  
60 hp to 1000 hp  
Waterblasters & Accessories  
Used Equipment Sales

**713-641-6006**  
www.boatmanind.com

**Aluminum Vacuum Tanks**

**ALUMATANK**

progresstank.com

**PORTAVAC**

**Septic & Restroom Service**

**T&T TOOLS** **T&T Tools**  
800-521-6893  
800-521-3260 FAX  
E-mail sales@tandttools.com • www.tandttools.com

Mighty Probe™  
Sludge Hoe™ (insulated)  
Sludge Spud™  
Manhole Hook  
Tommy Hook™  
Striking Head™

Handy Hook™  
Water Probe  
Curved Spud™  
Top Popper™  
Ground Buster™  
Smart Stick™ (standard)

www.tandttools.com

**JOIN THE DISCUSSION!**

**Pumper**

**Pumper Discussion Forum** is an online based tool for industry professionals to swap information and ideas on topics related to the liquid waste industry.

**Sign up today at**  
www.pumper.com

**ONSITE installer**

**ONSITE installer**  
Conquering Cold

For those who design, manufacture, engineer and install septic systems and other onsite wastewater treatment systems

**Subscribe today!**  
**It's FREE.**  
Call: **1.800.257.7222**

## SOFTWARE FOR YOUR INDUSTRY

Summit Rental Profit Builder™ & Summit Service Profit Builder™

*Business efficiency... NOW more than ever!*

### Rentals

Automatic Billing  
Pro-Rations  
Sales Tax & VAT  
Routing, Maps  
Automatic Credit  
Card Processing  
Receivables  
Inventory Control  
Exclusive ERIT™  
Proof of Service Unit  
Scanning  
QuickBooks® Link

### Services

Reminder Cards  
Diagrams, Maps  
Work Orders  
Job History  
Commissions  
Dispatching  
Receivables  
Auto Repeat  
Automatic Credit  
Card Processing  
Inventory Parts  
QuickBooks® Link

...and much more...

**Easiest to use!**  
We can transfer your data!  
Over 27 years experience!

Demos on line...or call for a Demo  
DVD or a personal guided tour

Summit

Ritam Technologies, LP  
Sales USA/Can 800-662-8471  
Sales Int'l: 208-629-4462  
Email info@ritam.com  
Web www.ritam.com

## FIND LEAKS and Sources of Odor

Quick • Inexpensive • Easy  
with the

# Superior® 5E



## Electric Smoker

Using Superior® Classic Smoke

1-800-945-TEST

www.SuperiorSignal.com

## One Complete Package

pumper.com  
promonthly.com  
mswmag.com  
cleaner.com  
onsiteinstaller.com

eq-mag.com  
pumpershow.com  
pumpertender.com  
septicyellowpages.com  
sewerpages.com

**COLE Publishing**  
1.800.257.7222 • 715.546.3346

## WATER JETS FOR RENT



- Units from 4,000 to 40,000 psi, including convertibles
- 60-800 hp, diesel or electric
- Rent, buy or lease
- Branches in MI, TX, NJ, CA, LA

**NLB Corp.** 1-877-NLB-7996  
www.nlbcorp.com

## EASILY MOVE RESTROOMS

- ✓ Aluminum Frame
- ✓ Ships UPS
- ✓ Carry ADA's
- ✓ Models starting at \$380



Available with 2, 4, 6 or even 8 wheels and your choice of air or solid foam tires.

### Super Mongo Mover®

**DA**  
Deal Assoc. Inc.

www.dealassoc.com  
866.599.3325

## SOIL SHAKER™ 2000

### Drainfield Restoration



- Pays for itself in 6 jobs or less.
- Buy factory direct
- Universal skid-steer attachment
- Made in the USA

VISA

Any questions feel free to call  
**320-293-6644**  
or visit our website at  
**www.soilshaker.com**

## PIT HOG PUMPS WASTE

LWT manufactures manned and remote controlled lagoon dredges and pumps. Rental dredges also available.



**LWT** LIQUID WASTE TECHNOLOGY.

1750 Madison Ave., New Richmond, WI 54017  
www.lwtpithog.com / 1-800-243-1406

## ARE YOU TIRED OF RAKING AND SHOVELING?

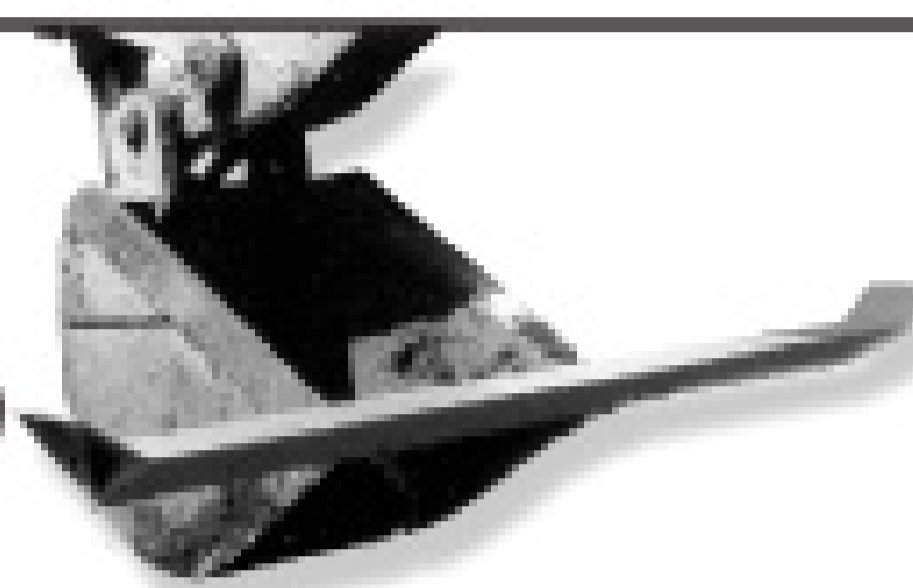

You should try a **HALL'S GRADE BLADE** on your backhoe or excavator.

- 4 sizes available, 4' to 10', for excavators
- 5 different sizes for rubber tire backhoes and mini-excavators

If you would like to know more, call us toll-free at

**1-888-372-8933.**

**HALL'S GRADE BLADE, INC.**  
www.gradeblade.com

WWW.ROOTERMAN.COM



Franchises available with low, flat fee  
New concept. Call 1-800-700-8062.

**FRANCHISE PACKAGE \$7,950.**

## PADLOCKS

- Your Padlocks
- Your Key Number
- Any Quantity
- Best Prices

**Quick-Shipped Anywhere!**

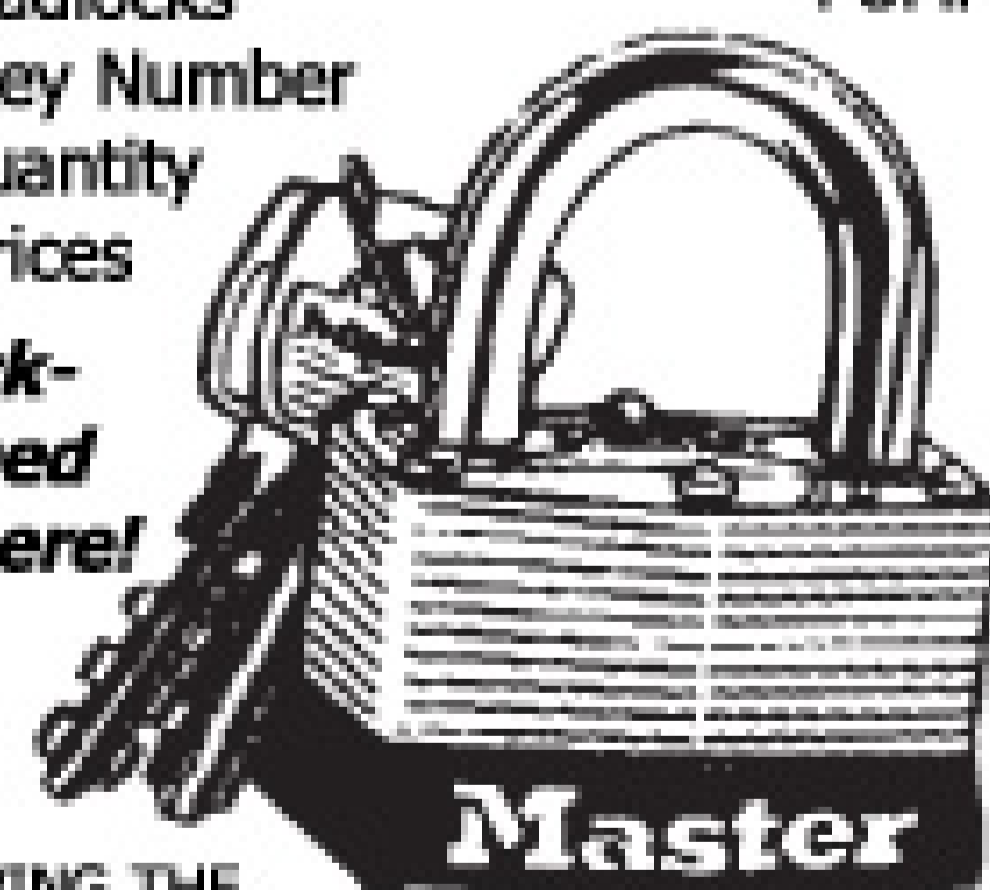

Master  
SERVING THE PORTABLE SANITATION INDUSTRY FOR 14 YEARS—WE'RE THE BETTER WAY TO BUY PADLOCKS™

Call For FREE CATALOG or Instant Quote!

**LockMasters**  
1-800-461-0620  
www.lockmastersusa.com  
sales@lockmastersusa.com • Fax (850) 914-9754

## BLOWERS

### Vacuum Blowers/Pumps

- Vacuums to 27" Hg
- Same day shipment from stock



### Pre-Piped Packages

- Capacities up through 30,000 CFM
- Ready to install
- Engineered to highest quality standards



- Complete Rebuilt Units
- Spare Parts Inventory

**1-800-250-7481**

**M Meyer**  
Wm. W. Meyer & Sons, Inc.  
1700 Franklin Boulevard, Libertyville, IL 60048  
www.wmwmeyer.com



## ASHLAND PolyTraps

Grease, Oil, Hair and Lint Traps and Interceptors

- NO Rust or Corrosion
- Lightweight
- Very Cost Effective
- Sizes up to 560 Gallons
- Made in the U.S.A.!

**LIFETIME WARRANTY!**

**Certified by U.P.C., IAPMO and P.D.I.**

**800-541-8004**

PolyTraps@Amplex.net  
www.ashlandpolytrap.com

# Mid-Continent Truck Sales, Inc.

891 Adkins Hill Rd. • Norman, OK 73072 • 405-329-5365 • Fax: 405-329-5381 • After Hours: 405-826-4469 • www.vacuumtrucksales.com

## Trucks - Trailers - Vacuum Tanks - Pumps



2003 IH 9100I, Cummins N14 (435 hp), 10-speed, double frame, new Wally 753LNHR vacuum pump, new 3800 gallon aluminum vacuum tank.



2000 IH 4700, DT466E, 5-spd., non-CDL, double frame, new Wally 403HR vacuum pump, new 1600 gallon vacuum tank.



1998 Freightliner FL60, Cummins 5.9 (210 hp), 6-spd., Masport H75V vacuum pump, General 47 series triplex, 1100/200 gallon vacuum tank.

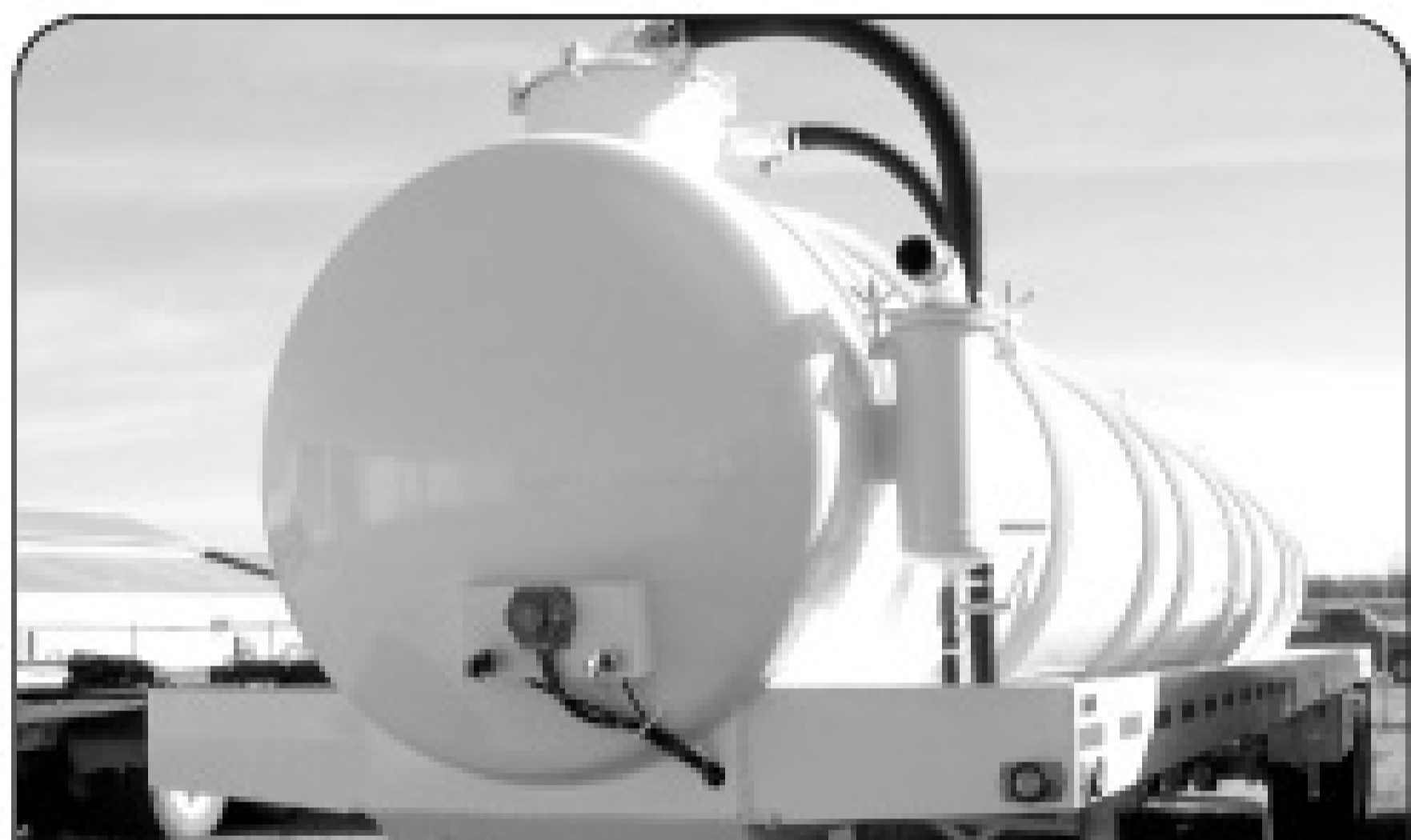

New Fluidmaster 5460 gal. vacuum trailer in stock. Also several used vacuum trailers in stock.



1999 IH 9900, Detroit 60 series (430/500 hp), 10-spd., new Wally 753LN vacuum pump, new 3000 gallon vacuum tank.

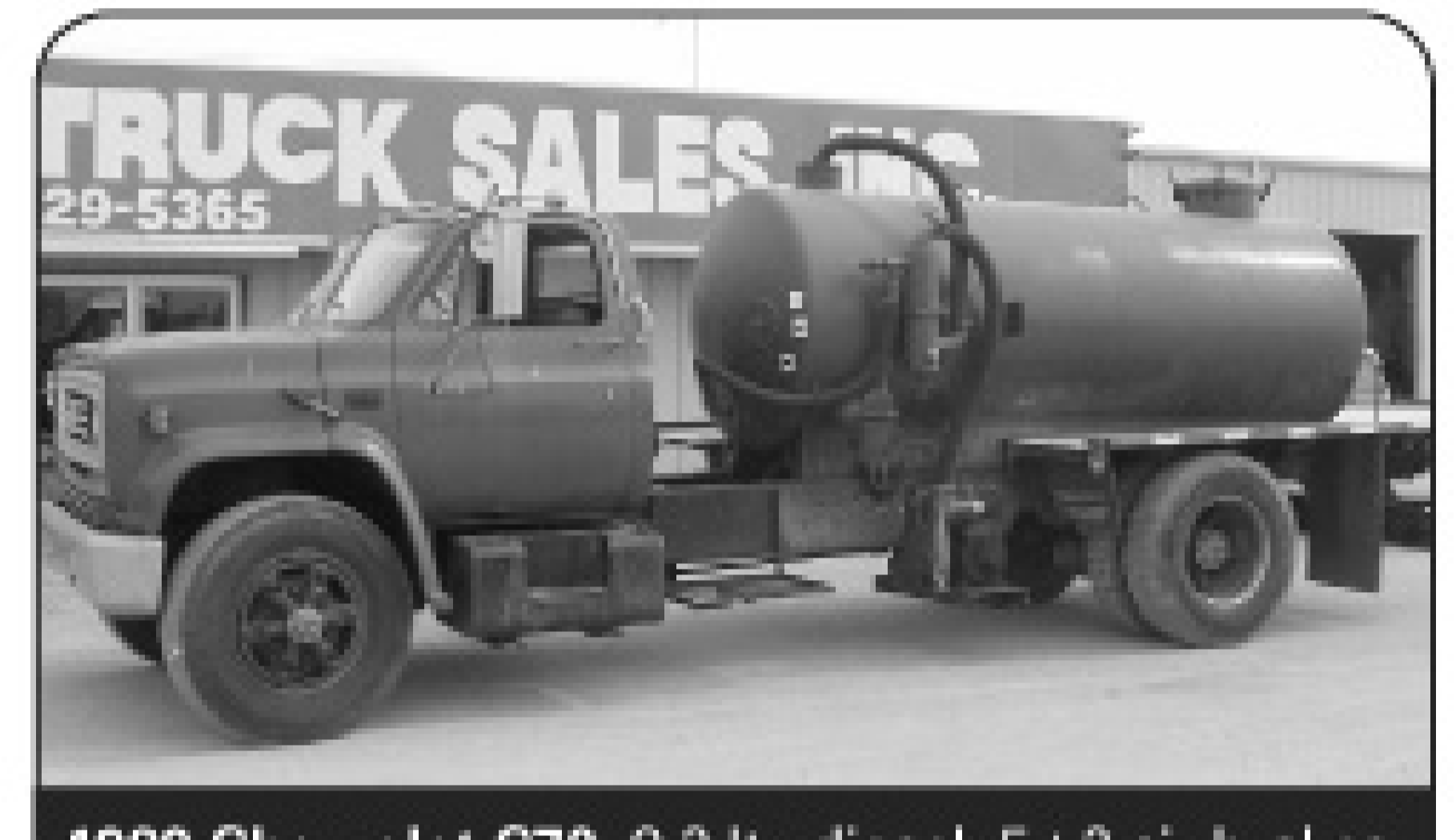

1989 Chevrolet C70, 8.2 ltr. diesel, 5+2 air brakes, double frame, MEC 5000 vacuum pump, 1500 gallon vacuum tank.



2001 IH 4900, DT466E, 6-speed, 33K GVW, air brakes, double frame, new Masport HXL75V vacuum pump, new 2300 gallon vacuum tank.

### CALL US BEFORE YOU BUY!

#### MID-CONTINENT TRUCK SALES

manufactures and stocks all necessary components to complete your vacuum system.

Whether it's pumps, valves, moisture traps, oil catch mufflers, pump frames, etc.



LET US QUOTE YOUR NEXT VACUUM TANK!

**Kerr**  
Pumps  
Since 1946



**Masport**

**NVE**

AUTHORIZED DISTRIBUTOR



**vallenstein**  
vacuum pumps

**BOWIE**



FLUID AND SLURRY  
**PUMPS**

WE CARRY MOST BRANDS OF VACUUM PUMPS AND PARTS!



WE WILL BUILD TOILET UNITS TO YOUR SPECS!

Call DAVE PERRY for TRUCK quotations and CHUCK RODGERS for TANK quotations.



- ▶ Advertising
- ▶ Aerators
- ▶ Bucket Machines
- ▶ Businesses
- ▶ Business Opportunities
- ▶ Cable Machines
- ▶ Computer Software
- ▶ Dewatering
- ▶ Drainfield Restoration
- ▶ Drain / Sewer Cleaning Equipment
- ▶ Dredges
- ▶ Excavating Equipment
- ▶ Hazardous Waste Units
- ▶ Hydroexcavation
- ▶ Jetties-Trailer
- ▶ Jetties-Truck
- ▶ Jet Vacs
- ▶ Lease Financing
- ▶ Locators
- ▶ Miscellaneous
- ▶ Parts & Components
- ▶ Pipeline Rehabilitation
- ▶ Portable Restrooms
- ▶ Portable Restroom Sinks
- ▶ Portable Restroom Tanks
- ▶ Portable Restroom Trailers
- ▶ Portable Restroom Trucks
- ▶ Positions Available
- ▶ Positions Wanted
- ▶ Positive Displacement Blowers
- ▶ Pressure Washers
- ▶ Pumps-Dredge
- ▶ Pumps-High Pressure
- ▶ Pumps-Submersible
- ▶ Pumps-Vacuum
- ▶ Pumps-Water
- ▶ Rodding Machines
- ▶ Roll-Off Containers
- ▶ Roll-Off Trailers
- ▶ Roll-Off Trucks
- ▶ Root Control
- ▶ Safety Equipment
- ▶ Septic Tank Forms
- ▶ Septic Trucks
- ▶ Service / Repair
- ▶ Slide-In Unit
- ▶ Sludge Applicators
- ▶ Tanks
- ▶ Tools
- ▶ Trailers- Vacuum / Tanker
- ▶ TV Inspection
- ▶ Vacuum Loaders
- ▶ Vanes
- ▶ Vehicle Tracking
- ▶ Wanted
- ▶ Wastewater Transfer
- ▶ Waterblasting

## ADVERTISING

**SANITATION POSTCARDS & BUSINESS CARD MAGNETS:** Remind your customers and prospects with color postcards and magnets. Economical marketing tools. Tradeshow handouts as well. Call Toll Free 888-334-4553. Visit [www.postcardprinting.com](http://www.postcardprinting.com). (PBM)

## BLOWERS

**VFC200P-5T, FUJI** Pumps, Regenerative Blowers, Ring Compressors. All models, accessories. Authorized distributor. Authorized parts and repair center. Call 888-227-9822. [www.carymfg.com](http://www.carymfg.com) (PBM)

## BUSINESSES

Well established septic pumping and installation business north of Boston. \$700,000+ annual gross. Includes: 2004 3600 gallon Peterbilt, 30,000 original miles, like new. 2006 Linkbelt 135 excavator, 300 hr., spotless, good as new. 2004 Hyundai 55 excavator, 600 hrs., original paint still on bucket. 2006 Tackahuchi skid steer TL130, 700 hrs., new tracks, perfect condition. Chevy C 6500 6-wheeler, very good condition. 1994 Kenworth 10-wheeler, all new tires, good condition. 2001 Chevy Cube van, good condition. 20-ton Eager Beaver trailer. Retiring. \$300,000 takes all. 978-462-3977. (P4)

FOR SALE: 23-year-old restaurant service company specializing in hood system cleaning and ceiling restoration. Serving WV, OH and KY. Large loyal customer base. Grossing average \$500,000. All vans, equipment and experienced service techs in place. \$350,000. Will train. 304-372-2158. (CP7)

Portable toilet business Central AZ, 3 trucks, approximately 200 toilets, 2 handicaps, wash stations, 200 gal. tanks. Over 100 units in service. 928-684-5033. (P4)

FOR SALE: Septic and Portable Toilet Business located in White Mountains, Arizona. 150 toilets, 2 ADAs, 3 trucks. For more info, respond to: 11448 East Monte Ave., Mesa, AZ 85209. (PBM)

## BUSINESSES

**BUSINESSES WANTED:** Septic pumping, grease trap, drain cleaning and other ancillary businesses wanted. We are buying well run businesses in New England, Mid-Atlantic and Florida. All opportunities will be given proper consideration. Confidentiality ensured. Will move quickly for the right opportunity. Serious inquiries only. Please contact Richard Bedard @ Blue Water, 617-326-3344 or [rbedard@bwseptic.com](mailto:rbedard@bwseptic.com). (CPBM)

Manitowoc County, Wisconsin. Located on seven acres near I-43 on State Highway 10. Septic tank manufacturing, installing and repairs business, Works accounting system with complete history of installations and repairs. Owners retiring. 25 years in business. Asking \$500,000. 920-732-3484. (P15)

For Sale: Portable Restroom company in Southeastern CT. 500+ units, 3 trucks: 2004 GMC, 2006 Izuzu - Crescent Tank, 2008 Ford F550. Serious inquiries only. 860-887-6542. (P4)

FOR SALE: Central Texas portable toilet business. Includes 2,500 units, 10 pump/route trucks, 6,000 gallon nurse tanker, 1 ACSI luxury restroom trailer. Great customer base. Email for more information: [centraltexastoilets@gmail.com](mailto:centraltexastoilets@gmail.com). (P4)

Long Island, New York: For Sale: Cesspool, Septic, Sewer and Drain Cleaning Company For Sale. 2 pump trucks, 2 porta-pottie trucks (service and delivery). Quality workmanship, has established 3000+ loyal customer base. Great opportunity for right person. Jump in on busy season! Money maker! Debt free! Office/shop/yard also available. Call for more information. 631-472-0677. (PBM)

Washington State Puget Sound septic design, installation, maintenance and repair business. Excavating equipment, pump truck, trailer, tools and truck. 5 year office, shop and yard lease available. Training for permitting, installation, maintenance, repair and licensing up to 5 years. \$360K. Terms 888-868-8599. (P4)

## BUSINESSES

LAUNDRY TRAILER: 2003 48' gooseneck, 12 washers/12 dryers, all 2009 electronic coin-opp Maytags. See photo at "Truck Stop", \$43,000. Can deliver, [VPS2000@MSN.COM](mailto:VPS2000@MSN.COM), 920-655-7065. (PT5)

## BUSINESS OPPORTUNITIES

**Attention PolyJohn Owners:** Receive a **free CD-Rom** of our products to use in your company marketing efforts. Ask your PolyJohn business coach in your area to send you this material today. 1-800-292-1305 Kell. (PBM)

If you are in need of a REGISTERED SEPTIC TANK CONTRACTOR to qualify your Florida-based septic company, send me an email @ [BLRSepticService@aol.com](mailto:BLRSepticService@aol.com) or call 561-723-5001. (P4C5)

27 yr. old Central FL DEP Approved Residuals Management Facility with tremendous growth opportunities. Looking for investor/partner to make 2 1/2 times investment in 5 yrs. or less. Backed by collateral or stock in company. 352-302-6073 or [fordhook@tampabay.rr.com](mailto:fordhook@tampabay.rr.com). (P4)

**National Grease Recycling Inc.** Let us teach you how to recycle restaurant's waste fryer grease and oil (yellow grease) only. **No trap grease.** Big \$. Over 30 yrs. experience. Will guide you through complete process from collection to processing to marketing to end users. Don't lose your trap business to competitors that offer both services. Call for information. Dewey Walker. 813-752-9535 or 813-758-2552. (PBM)

**WWW.ROOTERMAN.COM.** Franchises available with low flat fee. New concept. Visit web site or call **1-800-700-8062 x26**. (CPBM)

It's **EASY** to submit your classified **ONLINE!**  
Just go to:  
[www.pumper.com](http://www.pumper.com)  
Place a Classified Ad;  
Fill in the Online Form!

## COMPUTER SOFTWARE

Pumper Plus Billing Software: Regularly \$795. Mention this ad in Pumper.com and purchase for only \$595. Pumper Plus is a billing software package from Galaxy Systems, [www.galsys.com/pumperdemo.asp](http://www.galsys.com/pumperdemo.asp), that handles billing for septic pumping and portable toilet service-type companies. Inquire at [solutions@galsys.com](mailto:solutions@galsys.com) or call 800-985-3029. (PBM)

## DEWATERING

Septic Receiving Station, 10-gauge double wall stainless steel tank, w/4" flanged inlet. Wash assembly, 12" outlet, flow meter/plug valve rock trap stainless auger/brush and roll pins, stainless steel spray wash cast iron grinder/12" cutting chamber/7 tooth cam 4130 alloy steel/5HP/3.7KW 29:1 reducer controller/Pc2450-100503, operator interface, panel heaters, billing card reader, receipt printer, emerg. stop button, connection to scada system, 2HP/1.5KW serial# 100503. Contact Tim 832-473-7222. (P5M6)

2 meter stainless belt press, Polmor pump with controls, wash-down motor, will fit on tandem axle trailer, excellent cond. \$25,000. Call Steve 503-577-7223. (P6)

Aqua-Zyme 30-yard Dewatering Box, 2 years old, one owner. Excellent condition and ready to use. \$30,000 OBO. 317-539-7304 or 317-563-2072. (P5)

Buy - sell - trade - lease: Filter presses, belt presses, vacuum filters, filter cloth, dewatering bags, tanks, mixers and more! Call Waste Treatment Equipment Specialties at 440-808-8844. **www.wescoequip.com**. (PBM)

Alar, Model 650, very good cond. Completely automatic with all controls and panels, filters down to 1/2 micron, sludges generated by septic and grease haulers. Reducing BODs, F.O.Gs, TGS, total phosphorus, meters and NH3-N. 770-917-0377. (PBM)

## DRAINFIELD RESTORATION

2002 Terralift, 500 hours, 3 probes, excellent condition, many extras. Can deliver. \$15,000. 724-297-5435. (P14)

**DO YOU OWN A TERRALIFT MACHINE?** We have the beads in stock and we also have heavy duty probes. Toll Free 1-888-252-1006. (P4)

## DRAIN/SEWER CLEANING EQUIP.

1993 Vactor 2100 Series, 3 yard debris tank. Ready to work. \$8,000. Call for pictures or details. 407-351-0827. (P4C5)

RODDER TRUCK: (Sreco Flexible) 1990 Ford F450 w/123,000 miles, 7.3 L Diesel, auto tran, A/C, sectional rodder. Truck, tires and rodder motor in good condition, needs rodding segments replaced. Check website [www.ziamunicipal.com](http://www.ziamunicipal.com) for more information or call 614-419-4579. (CP5)

## DREDGES

Seepex sludge & polymer mixing & pumping unit. 5 years old. Excellent condition. Asking \$20,000 OBO. Call 1-506-672-2100. (PBM)

2002 Crisafulli Electric Dredge-210 hours, 50 HP J-Series elect. motor w/WEMCO booster pump model 6x4, 600 GPM @ 70' of head pressure, 20 HP motor. Includes 250' aluminum floating pipe, 160' flex hose, several feet of cable, 1 brand new roll, 4 cable jacks, disconnects and control cabinet. Excellent cond. \$37,500 Call 1-765-252-8220. (CP4)

## HAZARDOUS WASTE UNITS

ATTENTION: Fleet of Mack vacuum waste oil trucks for sale/trade by owner. Assorted size MC312 aluminum vacuum tanks. 417-619-5111. (PBM)

2009 Sterling LT9500 triaxle with a new Presvac, **Powervac** 3800, 3,250 gallon (US), DOT, wet/dry industrial, vacuum tank loader. (Stock #13336) **www.VacuumSalesInc.com, (888) VAC-UNIT (822-8648).** (PBM)

## HAZARDOUS WASTE UNITS

2010 Peterbilt 340s **loaded with every option except with auto-matics** with a new Presvac 3200 gallon carbon steel, DOT 412 certified, **full open rear door, dump style units.** PVB750 vacuum pumps. (Stock #TBD A,B,C&D) *In production.* **www.VacuumSalesInc.com, (888) VAC-UNIT (822-8648).** (PBM)

1986 Polar 5,000 gallon 316 stainless steel MC 307/312 vacuum trailer with new vac pump and hyd. drive. New tank inspections with new NVE valves. Spring suspension. In excellent condition. Must see. KLM Companies 617-909-9044. (P4)

NEW Presvac 5500 gallon c/s DOT certified vacuum tank unit, self-contained. **In stock!** (Stock #13373) **www.VacuumSalesInc.com, (888) VAC-UNIT (822-8648).** (PBM)

2000 Mack RD686 triaxle with 4,000 DOT certified dump and door Presvac vacuum tank. New Moro PM100 vacuum pump with new NVE valves and tank inspections. 350 hp engine with 44K rears with 15K pusher, 18K ft. axle. Must see. KLM Companies. 617-909-9044. (P4)

2009 Kenworth T800 steerable triaxle with new Presvac Powervac 3,800 cfm, DOT 412, wet/dry vacuum unit. 3,200 gallon tank with full open rear door with top loading boom. 475 hp engine with aluminum wheels and fully loaded. Buy or rent. KLM Companies/KLM Rentals Inc. Call 617-909-9044. (P4)

2000 Kenworth T300 cab and chassis with a Presvac 2010 US gallons, DOT certified vacuum tank. **In stock.** (Stock #4675C) **www.VacuumSalesInc.com, (888) VAC-UNIT (822-8648).** (PBM)

## JETTERS-TRAILER

New PipeHunter Model 38T44 jetting unit, trailer mounted unit, w/335 Poly water tank, 4,000 psi @ 25 gpm, 600' of hose and attachments. **In Stock!!!** (Stock #13317) **www.VacuumSalesInc.com, (888) VAC-UNIT (822-8648).** (PBM)

## JETTERS-TRAILER

New O'Brien Model 3518-SC jetting unit, trailer mounted unit w/350 poly water tank, 4000 psi @ 18 gpm, 400' of hose and attachments. **In Stock!!!** (Stock #3024V) **www.VacuumSalesInc.com, (888) VAC-UNIT (822-8648).** (PBM)

Used PipeHunter model 38T44 jetting unit, trailer mounted unit, w/335 poly water tank, 4000 psi @ 25 gpm, 600' hose and attachments. **In Stock!!!** (Stock #4313V) **www.VacuumSalesInc.com, (888) VAC-UNIT (822-8648).** (PBM)

2 SECA trailer jets. Both have Myers 35 gpm, 2000 psi pumps. New paint on both. Located in Dallas. 972-938-1905. [www.empireequip.com](http://www.empireequip.com). (CPBM)

## JETTERS-TRUCK

2000 SECA water jet. Front mounted, hose reel, Myers 50 gpm 3000 psi, 1500 gallon plastic water tank. Was a city owned unit. In excellent condition. 714-639-8352. [www.empireequip.com](http://www.empireequip.com). (CPBM)

1995 Harben, 925 hours, in excellent condition, mounted on 1998 Ford F800, 5.9 diesel hydromatic, 300 gallon water tank. Asking \$17,500. In Florida. Call 561-740-2010. Cell 396-4469. (P4C5)

2006 GMC TC6500 cab & chassis truck mounted jetting unit with JET EYE camera system, 3,000 psi @ 50 gpm, 1,000 gallons water, 600' hose, 500 cfm blower, debris tank and attachments. RENT ME!!! (Stock #13234) **www.VacuumSalesInc.com, (888) VAC-UNIT (822-8648).** (PBM)

## JET VACS

2008 Sterling LT7501 with a Vac/All All Jet Model AJV1215 1500 water comp, 12-yr. debris body, Roots 824 PD blower, 80 gpm @ 2000 psi jetting system with 600' of 1" hose. Combination vacuum-jetter unit. **In stock - RENT ME!!!** (Stock #0329V) **www.VacuumSalesInc.com, (888) VAC-UNIT (822-8648).** (PBM)

1998 Vac-Con V312THA on a Ford LT8000, 3-stage fan, 65 gpm, 2000 psi pump, extendible boom, articulating hose reel, 12 yard debris tank, new paint. Was a city owned unit. Located in Dallas. 972-938-1905. [www.empireequip.com](http://www.empireequip.com). (CPBM)

## JET VACS

2001 Vac-Con Model V390 SHA, 3-stage fan, 80 gpm 2000 psi pump, 600' of new 1" jet hose, new paint. Was city owned. 972-938-1905. [www.empireequip.com](http://www.empireequip.com). (CPBM)

1988 International DT466 engine, Allison AT with Model 815C Vactor, BT4 Cummins, 4500 hrs. \$49,900. Call 574-534-1301. (P5C6)

1998 Vac-Con Model V350THA, 3-stage fan, 50 gpm, 3000 psi pump, 5-yr. debris tank, new white paint. Was city owned. 714-639-8352. [www.empireequip.com](http://www.empireequip.com). (CPBM)

**Looking for a couple late model Vactors with low hours. Please contact Steve @ River City Environmental, Inc. 503-969-7591. SteveM@rivercityusa.com.** (CP5)

1996 Vactor Model 2110, **PD blower**, 65 gpm, 2000 psi pump, 10-yard debris tank, new paint. 972-938-1905. [www.empireequip.com](http://www.empireequip.com). (CPBM)

(1) 2002 Vactor 2110; (1) 2002 2115; (1) 2003 2110. **All PD units.** All were city owned units in excellent condition. Located in Dallas. 972-938-1905. [www.empireequip.com](http://www.empireequip.com). (CPBM)

CAMELS: 2008 Camel 200 DEMO unit, only 8,500 miles+/- Like new with Cat Diesel, Sterling tandem chassis, 10 cy dump, front reel mount, winter circulation and vacuum excavating packages, never titled. 1997 Camel 200 on Ford LT8515 tandem chassis. One owner truck with only 67,000 miles, Cummins 275 Diesel, auto shift, 10 cy dump body and behind the cab reel. 1990 Camel 200 on a Ford LNT 8000 chassis w/a Ford Diesel, auto shift, 10 cy body, front reel and only 42,000 miles, municipal owner. Check website [www.ziamunicipal.com](http://www.ziamunicipal.com) for more information or call 614-419-4579. (CP5)

Jack Doheny Supplies Inc. offers a full range of late model combo units and DOT industrial vacuum loaders. Call us @ 1-800-3DOHENY. (CPBM)

2008 Sterling LT7501 with a Vac/All All Jet Model AJV1215 1500 water comp, 12-yr. debris body, Roots 824 PD blower, 80 gpm @ 2000 psi jetting system with 600' of 1" hose. Combination vacuum-jetter unit. **In stock - RENT ME!!!** (Stock #0330V) **www.VacuumSalesInc.com, (888) VAC-UNIT (822-8648).** (PBM)

## JET VACS

1998 Vactor 2110 on a Freightliner FL80, 28,213 miles, 2-stage fan, 80 gpm, 2,000 psi pump off system accumulator. Was a city owned unit. Located in Dallas. 972-938-1905. [www.empireequip.com](http://www.empireequip.com). (CPBM)

## LEASE/ FINANCING

**BSM Financial Group** is a nationally recognized finance company. We offer flexible payment schedules for all types of equipment new or used. Trucks, pumps, jetters, portable toilets, and software easily financed. We do first time start-ups, established businesses, and challenged credit. **Call Brett at 877-524-7972 or email [brett@bsmfinancialgroup.com](mailto:brett@bsmfinancialgroup.com).** (PBM)

**North Star Commercial Credit:** Commercial Loans for Trucks or Equipment. Flexible purchase programs to fit your budget. 21 yrs. in the industry. Contact **Tom Myers - 877-804-2274.** (CPBM)

**Grow Your Business Today!** Get competitive financing. No payment for 6 months. Seasonal plans! No age restriction. Don't wait. Liberty Capital Group, Inc. 888-798-3976. (PBM)

## MISCELLANEOUS

2004 Wee Engineer 27', 12-unit hauler, either 12 standard units or 8 standards + 1 handicap. Excellent condition. \$5,500 OBO. 815-970-7253. (PT4)

**Top quality aerators at wholesale prices.** We have replacement units for most name brands and also carry Linear Regenerative Rotary Vane pumps. Flagg Air, Gast, Thomas, FPZ, Secoh, Medo and more. Call a company that understands aerators and aeration systems. Septic Services Inc. 800-536-5564. (CPBM)

## PARTS & COMPONENTS

PARTS & SERVICE for vacuum pumps and vacuum tanks. Vacuum pumps also in stock. 800-909-6909. Ask for Ken or Randy. (PBM)

BUY IT - SELL IT - PLACE IT - [www.pumper.com](http://www.pumper.com) - AVAILABLE ANYTIME, ANYWHERE, ANY DAY

## PORTABLE HAND-WASH STATION

POLYPORTABLES SUPER TWIN HANDWASH STATIONS: 1 year old, used once. \$395 each. 715-896-0413 or 715-284-5979. (P5)

## PORTABLE RESTROOMS

250 Red, White & Blue PolyPortable (Integra) units in excellent condition. \$275-\$350 each. Handicaps also available. Please call 352-572-2687. (PBM)

For Sale: 30 to 50 used Poly-Portable restrooms, 8 to 9 years old, in good condition. Selling in lots of 10 or more at \$125 each. Call 410-795-2947. (P4)

50 Aquamarine PolyPortable Integra 2, excellent condition, \$325 each. 10 Burgundy Synergy Taurus restrooms, all in excellent condition, \$325 each. 3 Satellite ADA compliant handicap restrooms, all need new roofs, \$800 each. 7 older PJ3 PolyJohn Fleet series, 4 yellow, 3 green, in excellent shape, \$250 OBO. Call 406-728-3533. (P4)

500 Olympic Fiberglass units for sale. Units are older construction grade. Located in Albuquerque, New Mexico. \$100 each. Call 505-345-3965. (PT4)

200 Used Fiberglass Toilets for Sale. Excellent condition, some as new as 2007, some older. \$75-\$100 each depending on age. Call Lorraine 847-955-1214. (P9)

50 PolyJohn PJN3 - FOB Spokane - \$250/ea. 509-244-8404. (P4)

35 used portable toilets, \$175 each. Good condition. 10 used 250 gallon holding tanks, \$100 each. Call 888-463-7687. (PT4)

Used PolyJohn, PolyPortable tan units, plastic skids, average to excellent condition. \$225-\$325 each. Can arrange shipping. Call Bob at 1-352-796-4540. (PBM)

Over 600 PolyJohn units 1-2 years old. Starting at \$300 each. Minimum purchase of 26 units. 772-562-4604. kim@reliablepolyjohn.com. (PBM)

**Portable Toilets:** Poly constructed, molded seat, urinal, latching door. Handicap accessible units available. New and used. CCI/Brian Touey 805-896-3777. (PBM)

## PORTABLE RESTROOMS

New and used portable restrooms for sale in Middle Tennessee area. Contact: Tony 931-320-2255. (P5)

## PORTABLE RESTROOM TANKS

300 gallon, 225 waste/75 water, brand new, Battioni pump. \$5,500. 315-375-7867. (PBM)

Single or multiple compartment tanks. Choose mild, stainless, or galvanized steel. Capacities from 100 to 6000 gallons, any diameter. Parts and accessories to build your own and save money. 800-545-0174. www.tanksandpumps.com. (PBM)

## PORTABLE RESTROOM TRAILERS

NEW RESTROOM TRAILERS, MANUFACTURER DIRECT. Cut out the middle man. 2-10 stall toilet/shower trailers in stock. Brad. 800-726-4022. (P6)

1998 24' Olympic Trailer. Mens side has 3 urinals, 2 stalls, 1 sink. Womens side has 3 stalls, 1 sink. Trailer upgraded to be completely self contained for low water needs and waste tank efficiency. This trailer handles large crowds with ease. \$15,000. Call Rich at 219-405-0405. (P6)

2008 ACSI Advantage Plus Restroom Trailer, 16', upgraded interior, 1 year old, winter package, ac/heat, stereo. Call Chris or Jeff at 217-224-1932. (PT4)

2006 Wells Cargo Comfort Elite III. Light use, stored inside. \$19,750. 573-896-8665. (PT5)

Polyjohn 40' Event Trailer, newly remodeled with all new floors, walls and sinks. It has a family changing room. Asking \$35,000. 509-244-8404. (P4)

**Restroom Trailer - Gold Series:** 32', new and used. Women's - 5 stalls, 2 sinks. Men's - 2 stalls, 2 urinals, 2 sinks. CCI/Brian Touey 805-896-3777. (PBM)

New and used **RESTROOM TRAILERS** available immediately. 8 to 34 foot luxury trailers. Comforts of Home Services Inc. 877-382-2935. (PBM)

## PORTABLE RESTROOM TRAILERS

**Restroom Trailer - Platinum Series:** 30', new and used. Women's - 4 stalls, 2 sinks. Men's - 2 stalls, 3 urinals, 2 sinks. CCI/Brian Touey 805-896-3777. (PBM)

2008 24' Olympia Executive, never used, paid \$28,700, will take \$26,000. 2004 Olympia 20' Executive, excellent condition, \$18,000. 2000 Olympic 30' Luxury Liner, \$20,000. 2001 Olympic 26' Executive, \$17,000. Call 866-883-9538 NY. (PT5)

## PORTABLE RESTROOM TRUCKS

**NOW AVAILABLE: '08 Isuzu NPR-HD Chassis/Model 800 Crescent Rectangular Vacuum Tank. REDUCE** fuel costs and **IMPROVE** productivity with the **All-In-One** vehicle (service & pick-up/delivery). Take advantage of 2008 pricing. Call for quote today. **Crescent Tank Mfg.** 585-657-4104; www.crescent-tank.com. (P4)

2001 F-550, Satellite 600/250, 7.3 4x4, auto, 108,000 miles, dual side service, wet baskets, carrier, spare vac, water pump, control and tires. \$31,000 OBO. 231-250-1483. Michigan. (P4)

2005 Ford F550, diesel, auto., Satellite tank, 350 fresh, 600 waste, 2-unit carrier. \$25,000. 800-275-3616 NY. (PT5)

2007 Isuzu flat tank can haul 6 toilets, 550/250, less than 7000 miles, \$52,000. 2001 F550 7.3, \$12,900. New transmission, 195,000 miles, clean truck, work ready. 270-784-2731 anytime. (P4)

2005 Ford F550 Super Duty diesel pump truck. White with gray interior, Best built with a 1050 gallon stainless steel tank, PTO driven Masport pump, 75,000 miles. Perfectly maintained by Gabrielli Ford in Jamaica, NY. Wholesale price of \$27,500. 800-634-2085. (P4)

2007 Ford F-550. Satellite set up with a 600 gal. waste and 300 gal. fresh. Low miles, 54,755. Like new. \$38,500. Please call 314-776-4000. (P4)

1990 International pumper truck, 300/600. Asking \$18,000. 509-244-8404. (P4)

## PORTABLE RESTROOM TRUCKS

1998 International 4700 with a 1,500 US gallon, 2-compartment (1100/400 split), carbon steel, portable toilet service unit. (Stock #8734C) **www.VacuumSalesInc.com, (888) VAC-UNIT (822-8648).** (PBM)

1996 Chevrolet 3500. Engine and transmission have been replaced in the last year. Steel tank, 800 gal. 600 waste/200 fresh water. Jurop pump, powered by gas Honda engine. Sale price is \$10,000. Call 352-446-0475. (PT5)

1998 International 4700 cab and chassis with a Coleman 1,000 US gallon, 2-compartment (700/300 split) carbon steel portable restroom service unit. **Available!!!** (Stock #1327C) **www.VacuumSalesInc.com, (888) VAC-UNIT (822-8648).** (PBM)

2000 F-650, non-CDL, 6-speed, diesel, AM/FM, A/C, 700 waste/250 fresh water, Masport pump, aluminum tool boxes, heavy duty hitch, 2-unit carrier. Unit is in great condition. Must sell. Contact Clifton at 317-730-5311. (PT5)

1994 International 4700 with a Keith Huber 1,500 carbon steel portable toilet service unit. (Stock #6499V) **www.VacuumSalesInc.com, (888) VAC-UNIT (822-8648).** (PBM)

2001 Isuzu FTR, 2005 Crescent tank pumper, 25,900 GVW, 152,000 miles, runs good. New transmission, new tires, 1000 waste, 300 fresh. Will trade for restroom trailer. \$28,850. FSBO. 585-657-1010. (PBM)

1995 International 4700 with a Prime 1,500 US gallon, 2-compartment (1000/500 split) carbon steel; portable toilet service unit. "As is." **Available!!!** (Stock #3469C) **www.VacuumSalesInc.com, (888) VAC-UNIT (822-8648).** (PBM)

1998 F-800 w/stainless 200/100, 5.9 Cummins w/Allison auto, 80,000 miles, holds 10 units. \$20,000 OBO. 334-319-1412. (PT4)

1999 Freightliner w/automatic with a Keith Huber 1,000 waste, 500 water, toilet service unit. (Stock #4506V) **www.VacuumSalesInc.com, (888) VAC-UNIT (822-8648).** (PBM)

## PORTABLE RESTROOM TRUCKS

2004 4300 International, 25,500 GVW, DT466, Allison, A/C, air-brakes, 3-compartment aluminum tank (450/1400/250), M-10 Water-cooled pump, spot lights, 2 Burk water pumps for fill and spray down, restroom carrier. Pictures www.aacoinc.com/classified. Located Phoenix, AZ. \$45,000. 208-362-3193. (P4)

1994 Ford with Coleman 700 waste, 300 water toilet service units. (Stock #6084V) **www.VacuumSalesInc.com, (888) VAC-UNIT (822-8648).** (PBM)

**2002 International Pumper Truck:** 4700 series, DT466, automatic, air brakes, 1200 gallon waste, 300 gallon fresh water, Masport 75 pump. CCI/Brian Touey 805-896-3777. (PBM)

New 700 US gallon 2-compartment (450/250 split), carbon steel, portable toilet service unit. (Stock #13238V) **www.VacuumSalesInc.com, (888) VAC-UNIT (822-8648).** (PBM)

2008 Ford, 49,000 miles, \$45,000. 2007 C5500 Chevrolet, miles in 40s with aluminum and steel tanks. Still under warranty. Slide-ins 600/200, \$10,000. Portable toilet transport trailers: 8, 10, 12, 14, 16, 20 haulers. New portable toilet trucks and new and used septic trucks. We stand behind everything we sell. Lane's Vacuum Tank Inc. 1-800-592-3308. (PBM)

2006 Peterbilt 366, less than 2,000 miles, 6-spd., 2600 GVW. Progress aluminum tank 1500/500. Masport pump, water pressure, scent tank. Like new! Call for info and pictures. 512-461-2419. (P4)

1999 Isuzu FTR, 190 hp, 6 cyl. diesel, 25,900 GVW, new Allison auto with 2-yr. warranty, Jay's Inc. 1,300 gallon 800/500 split, National 190 cfm vac. pump, Burks DC-10 wash down pump, heated dump valve, heated bucket fill, heated water pump, 60' hose reel, 2-unit toilet carrier, and more. 123,800 miles. \$35,000. Call Dale 708-878-4391. Located in Illinois. (PBM)

IF YOU ARE USING AN  
**800 NUMBER**

IN YOUR AD, BE SURE IT CAN BE USED IN ALL  
AREAS NATIONWIDE.

## POSITIONS AVAILABLE

Established Industrial & Municipal Cleaning Company seeks Operations/Regional Manager and Sales Manager. Both successful applicants need to be self motivated, hands-on, good communicators, willing to travel & learn the position throughout Arizona. Business based close to Tucson, AZ. Salary based DOE. Benefits, 401K, plus other incentives for the right applicant. Fax resume to 520-385-0557. (P4C5)

## POSITIVE DISPLACEMENT BLOWERS

NEW Gardner Denver PD blower, size 1426. 6,000 cfm at 15 psig, 12,000 cfm at 8 psig. Lists for \$48,000+. \$9,500. 843-271-4239. (CMP4)

## PUMPS-SUBMERSIBLE

(2) 4" submersible pumps with self-contained Lister diesel engine, hyd. drive powerpac. Separate hyd. tanks, both on portable skids. Will run (2) 4" pumps or (1) 6". Must see. \$12,500. KLM Companies 617-909-9044. (P4)

Wholesaler for Hydromatic, Zoeller, Myers, Liberty and ABS pumps. We also supply Grinder pumps and basins. Will help you size them. Septic Services Inc. 800-536-5564. (CPBM)

## PUMPS-VACUUM

Complete line of Moro, Conde and engine-driven, stand-alone pump systems, DC10 washdown pump. Call us for any of your vacuum truck parts from shut-off valves, primary and secondary valves, hoses, vacuum pumps and drive systems. Septic Services Inc. 800-536-5564. (CPBM)

Need a vacuum pump for your portable pumper? Try our new 30 cfm, 12 volt system. Less noise, no fuel. Automatic oiling, cheaper than a gas engine. 800-545-0174. [www.tanksandpumps.com](http://www.tanksandpumps.com). (PBM)

Vacuum Pumps - New, used, or rebuilt. 30 to 900 cfm. All major brands; air, water, or fan cooled. Rebuild specialists - rebuilt PB, M3, M10, and others available. 800-545-0174. [www.tanksandpumps.com](http://www.tanksandpumps.com). (PBM)

## PUMPS-VACUUM

New **Masport** and **Jurop** vacuum pumps. Compare our price before you buy. W-K Machine & Supply Co. Call 1-800-633-8947. Distributor. (PBM)

FRUITLAND RCF 800 VACUUM PUMP: Brand new. \$10,000 Canadian. Call Brent 905-642-2132. Toronto, Canada. (P4)

## RENTAL EQUIPMENT

Liquid vacs, wet/dry industrial vacs, combination jetter/vacs, vacuum street sweeper & catch basin cleaner, truck & trailer mounted jetters. All available for daily, weekly, monthly, and yearly rentals. **VSI Rentals, LLC, (888)VAC-UNIT (822-8648) www.vsirentalsllc.com.** (PBM)

## ROLL-OFF TRAILERS/TRUCKS

1993 Galbreath AC416 single container roll off trailer. Bridge weight design, just sandblasted and painted with aluminum Budds. Good condition. \$17,500. KLM Companies. 617-909-9044. (P4)

## SEPTIC TRUCKS

2001 Freightliner, 140,000 miles. 2,800 gallon aluminum Presvac tank with water cooled Masport pump, AM/FM, A/C. \$39,000. Call 609-294-0825 or 609-226-1726. (P4)

Two Septic Tanks Rigs For Sale. One 16' long with 15,000# hoist and one 18' long with 18,000# hoist. Both like new and made by Taylorsville Precast. 1-888-527-7700. (P4)

2000 Volvo WG64 with a Pikrite 4,000 gal. vacuum tank and a Jurop PNR-102 pump. (Stock #9010C) **www.VacuumSalesInc.com, (888) VAC-UNIT (822-8648).** (PBM)

1984 KW900 Cummins, 300 gal., tank hoist, vibrator, pressure washer/jetter, digital gauge, large toolboxes, Engle made, runs good. \$22,000 OBO. 765-489-5559. (P4)

1995 International 4900 DT466 tank truck, 6-speed, air conditioning, 2200 gal. tank, rebuilt transmission, new PTO, new Moro pump, 161,012 miles. Asking \$19,900. Call John at 914-755-0956 to discuss. (P4)

## SEPTIC TRUCKS

3360 gallon septic/vacuum truck, 2003 Sterling, 137,500 miles, A/C, heat, CD-radio, new injector pump, 300 Cummins, heated valves, 367 Challenger pump. 307-272-4848. (P4)

2002 Presvac 4,000 US gallon C/S tank only. (Stock #6255V) **www.VacuumSalesInc.com, (888) VAC-UNIT (822-8648).** (PBM)

1999 Sterling septic pump truck, 2500 gallon tank, Masport pump. Want to sell or trade for non-CDL truck. 706-556-1919. (P4)

2003 International 7500 with a 3,000 gal. carbon steel vacuum tank unit. (Stock #2319C) **www.VacuumSalesInc.com, (888) VAC-UNIT (822-8648).** (PBM)

1984 IHC w/DT466, w/Jay's 2,600 gal. tank, 250 cfm pump, 90,000 miles on complete new motor, transmission and rear end. New tires. Available June 2009. \$19,500 OBO. 715-644-2332. (P4)

2001 Ford F750, diesel, 6-speed, air brakes, new injectors, 2000 gallon vacuum tank, Battioni pump, 180K miles. \$30,000 OBO. Hamilton, Mich. 616-218-3155. (P4)

2001 Progress 4,800 US gallon C/S tank only. (Stock #0138C) **www.VacuumSalesInc.com, (888) VAC-UNIT (822-8648).** (PBM)

TWO SEPTIC TRUCKS FOR SALE: 1990 International and 1995 International. Both have 2300 gal. tanks and Masport pumps. One tank is 4 years old; the other is 2 years. Both in good shape. \$20,000 for 1990 model; \$25,000 for 1995 OBO. 256-490-8089. (P4)

1992 Ford LN9000 with new 4,000 US gallon carbon steel vacuum pressure tank, Presvac PV 750 vacuum pump. 44K rears, 18K ft. axle, 145,000 miles, in excellent condition. \$37,500. KLM Companies. 617-909-9044. (P4)

2006 International 4300 DT466, 6-speed, 2150 gal. steel tank, Jurop R260, 90K miles, A/C. Good clean truck. 1 owner. \$48,000. 903-852-3740. (P4)

2003 Mack CV713 cab and chassis with a 3,200 gal. s/s vacuum pressure tank. Masport pump package. **Coming soon!!!** (Stock #3680V) **www.VacuumSalesInc.com, (888) VAC-UNIT (822-8648).** (PBM)

## SEPTIC TRUCKS

1999 Sterling with a 2,500 US gallon CS dump type unit and pump package. (Stock #2192V) **www.VacuumSalesInc.com, (888) VAC-UNIT (822-8648).** (PBM)

2001 Intl. DT-466, 7-spd. tandem, new 3600 gal. tank, Masport 350 cfm vacuum pump, 237,000 miles, \$49,000. 2000 Intl., DT-466, auto., new 2300 gal. tank, 350 cfm Masport pump, 147,000 miles, \$44,000. Other new & used toilet & septic trucks available. Everything we sell has warranty. Lane's Vacuum Tank Inc. 1-800-592-3308. (PBM)

2001 International 4900 with a 2,000 gallon, vacuum tank and a Fruitland pump. (Stock #9960C) **www.VacuumSalesInc.com, (888) VAC-UNIT (822-8648).** (PBM)

Need a tank and truck, any size, any make truck? Let us help you get the best deal. Custom built to your specs. For information and a price quote call 800-545-0174. [www.tanksandpumps.com](http://www.tanksandpumps.com). (PBM)

2009 Peterbilt 340 with a Presvac 3600 gallon (US) aluminum vacuum tank unit. **Special Show Pricing!** (Stock #13337 A,B,C&D) **www.VacuumSalesInc.com, (888) VAC-UNIT (822-8648).** (PBM)

1992 GMC Topkick, good condition, runs well, A/C, 176,000 miles, 2100 gallon tank, Jurop pump. \$24,500. Chicago area. 815-741-4440. (PBM)

1997 Peterbilt Model 357, CAT 3306 motor, Fuller 8-speed trans., 4200 gal. Transway tank, 800 Transway pump, 220K miles, red. Excellent condition, ready to work. \$55,000. 978-618-6110. (PBM)

2006 Peterbilt 335 with a Presvac 3,600 gallon aluminum vacuum pressure tank with a Masport pump package HXL400WV liquid cooled. (Stock #7504V) **www.VacuumSalesInc.com, (888) VAC-UNIT (822-8648).** (PBM)

## SERVICE/REPAIR

**Sewer Cam Reel, Camera and Locator Repair:** 48-hr. turn-around time. General Wire, Ratech, Ridgid, Pearpoint, Electric Eel, Gator Cams, Insight Vision, Vision Intruders. Quality service on all brands. For more info. give Jack a call. Dynamic Cable Repairs, Lodi, NJ 07644. 973-478-0893. (PBM)

## SHOWER TRAILER

**Shower Trailer - Gold Series:** 32', new and used. Men and women sides each have 3 private shower stalls with changing area, 1 restroom stall, 1 sink. CCV/Brian Touey 805-896-3777. (PBM)

## SLIDE-IN UNITS

New 500 gal. slide-in unit, 5.5 Honda electric start, 73 cfm Masport pump, vac/pres. Financing available. Call for details. \$6,850. 785-231-0834. (P4)

Vacutrux slide-in portable toilet unit, 450 gal. waste, 210 gal. fresh, all galvanized, new Honda engine, very good shape. \$6,500. 716-676-3388. (P4)

750 gal. compact service unit, Honda 5.5 electric start, Masport 73 cfm vac/pres. pump Financing available. Call for details. \$11,500. 785-231-0834. (P4)

## TANKS

WANTED: Good used 2500 gallon tank for septic truck. Aluminum or steel. Call 903-786-3198. (P5)

FRAC TANK: 16,000 gal., steel, exterior rings, front & rear, 3" disch. w/valves, top loading, ladder & catwalk, skid mt. w/rear rollers, prime condition, clean, PWC Ind. 1991. \$12,950. Atlantic 904-387-3276. (P4)

Used 2003 portable toilet Satellite MD 950 tank in excellent condition. Includes work lights, toolboxes, freshwater pump, 650 waste, 300 fresh, ready to mount on truck. Includes 2-toilet carrier and Conde 6SS vacuum pump. \$11,000 OBO. 231-924-8994. (P4)

1991 PV3300 tank with PV750 pump complete with PTO, pump tray, muffler. In good working condition. Asking \$7,500 OBO. Pictures available. Call 1-203-838-7000 or email [davekbseptic@yahoo.com](mailto:davekbseptic@yahoo.com). (CP4)

Vacuum tanks, 100 to 6000 gallons. All options available; hatches, primary, secondary, valves, catwalks, ladders, etc. Everything needed to build your own septic truck. Choose mild, stainless, or galvanized steel. Ask about full open doors. 800-545-0174. [www.tanksandpumps.com](http://www.tanksandpumps.com). (PBM)

BUY IT - SELL IT - PLACE IT - [www.pumper.com](http://www.pumper.com) - AVAILABLE ANYTIME, ANYWHERE, ANY DAY

## TANKS

2002 Presvac 4,000 US gallon c/s tank only. (Stock #6255V) **www.VacuumSalesInc.com, (888) VAC-UNIT (822-8648).** (PBM)

2001 Progress 4,800 US gallon c/s tank only. (Stock #0138C) **www.VacuumSalesInc.com, (888) VAC-UNIT (822-8648).** (PBM)

**New 3400 gallon tank.** 20' man-way bottom, 3" intake, 4" dump, hose trays, valves, painted. \$12,000. 4000 gallon and many other sizes available. Delivery available. 800-721-2774. (PBM)

## TANK TRAILER

3,750 gal., Butler 1982/83, aluminum single compt. w/baffles, exterior rings, 3" discharge, tandem axles, 11R:24:5 radials, air brakes, clean, excellent condition. For: Liq. waste, vacuum, etc. \$8,950 each. Atlantic 904-387-3276. (P4)

6500 gal., stainless rd., 1978 Karry Kool, 316SS, 1-compt., insul. w/ss jacket, bot. rear 3" disch., side & front disch. w/ss valves, tandem axles, 11R:22:5 radials, air brakes, clean, fully equipped. \$14,500. Atlantic 904-387-3276. (P4)

6200 gal., stainless, 304SS, 1979 Citation trailer, round, single compt., fully insul. w/SS outer jacket, bot. rear 3" disch., w/valve, tandem axles, radial 11R:22:5 virgin tires, air brakes, top load, fenders, L/gears, clean, excel. \$12,950. Atlantic 904-387-3276. (P4)

NEW Presvac 5500 gallon c/s, DOT certified vacuum tank unit, self-contained. **In stock!** (Stock #13373) **www.VacuumSalesInc.com, (888) VAC-UNIT (822-8648).** (PBM)

## TOOLS

**T&T Tools:** Probes, Hooks. Probes feature steel shafts with threaded and hardened tips. The insulated **Mighty Probe™** tested to 50,000 volts. **Top Poppers™** open manhole covers easily. Free catalog. **www.TandTtools.com.** Phone **800-521-6893.** (CPBM)

**Crust Busters** - Portable, lightweight machine guaranteed to mix up septic tanks and grease traps! Save time and money! **www.crustbusters.com,** 1-888-878-2296. (PBM)

## TOYS

Septic pumper and vacuum die-cast toy trucks in your choice of colors and logos. Several cabs available. Call 877-450-2100 or write to Granite State Collectibles, PO Box 440, New Ipswich, NH 03071. (PBM)

## TRAILERS VACUUM/TANKER

5,000 gal. vacuum tank trailer, 1978 Strick, steel, single compt., rear 36" manway, domed ends, full chassis, walkways, tandems, 22:5 radials, air brakes, clean, excellent condition. Your vac pump. \$12,950. Atlantic 904-387-3276. (P4)

Presvac 5500 gal. 316 stainless steel DOT certified vacuum trailer, new Fruitland 500 vac pump w/complete rebuilt Lister diesel engine. Original tank thickness; new tank inspections, no pitting. Excellent overall condition w/new Imron paint. Must see. KLM Companies 617-909-9044. (P4)

## TRAILERS VACUUM/TANKER

1988 Heil 5,200 gallon stainless steel vacuum trailer. Spring susp. with disc wheels, 70% plus brakes and tires. Clean trailer. KLM Companies. 617-909-9044. (P4)

## TRUCKS (MISC.)

SEPTIC TANK SET TRUCK, 2001 FL 70, 6-spd. automatic, low mileage with new 16' hydraulically operated bed. The Shaddix Co. 256-338-4987. (PI5)

## TV INSPECTION

1993 GMC Cues TV truck with Dataview III. No camera or tracker. \$10,000. 407-351-0827. Call for pictures or details. (P4C5)

Pearpoint TV Inspection Trucks: 1995, mounted in Isuzu NPR, turbo diesel, low miles, two cameras with small & large transporters, diesel generator, many extras. \$30,000. 559-276-0186. (CP4)

For Sale: Cues Nite Owl pan and tilt camera in excellent condition. \$7,000 (CDN). 506-624-3993. (CP4)

## VACUUM LOADERS

1999 International **heavy spec** with **Guzzler ace** wet/dry industrial vacuum loader. 8" top load boom truck is in excellent condition. Blower was reconditioned approximately one year ago. RENT ME!!! (Stock #7390V) **www.VacuumSalesInc.com, (888) VAC-UNIT (822-8648).** (PBM)

## VACUUM LOADERS

2002 Volvo with 02' GapVax HG57 wet/dry 5,300 vacuum loader, CFM 27" blower, pressure off load, low miles, in excellent condition. Buy or rent. KLM Companies. 617-909-9044. (P4)

2009 Sterling LT9500 triaxle with new Presvac Powervac 3800, 3,250 gallon (US) DOT wet/dry industrial, vacuum tank loader. (Stock #13336V) **www.VacuumSalesInc.com, (888) VAC-UNIT (822-8648).** (PBM)

1997 Ford LNT9000, Guzzler, C-11 Cummins, Roots 1021, 27", 5000 cfm, \$59,000. 1995 Ford LNT9000, Vactor XPS, Cat 3176, Hibon, 27", 4600 cfm, \$38,000. 1994 Ford LNT9000, Guzzler, Cat 3406, Roots 1021, rebuilt in 2006, 27", 5000 cfm, \$42,000. 1994 Ford LNT9000, Vactor XPS, Cat 3406, Hibon 27", 4600 cfm, \$38,000. 1993 Ford LNT9000, Cusco MasterVac, Cat 3406, Hibon 27", 4600 cfm, \$43,000. 1989 Ford Vactor 2045, 1020 Holmes 16", 4500 cfm, \$23,500. 1989 Mack Vactor 2045, 1020 Holmes 16", 4500 cfm, \$25,000. All wet/dry units are certified and working as required. Call Rob at 519-384-3416. (P4)

2000 Sterling with Cusco Mastervac 3,800 CFM 27" blower with 3,000 gallon tank. Wet/dry unit with full open rear door and Moro vacuum offloading pump. Low miles/hours. Ready for work. KLM Companies 617-909-9044. (P4)

1992 Ford with Guzzler 4816 with swing out Cyclone 6,000 CFM blower (4 yrs old). Cat engine with Fuller trans. 150,000 miles, 5,000 hours. Runs very good. \$22,500. KLM Companies 617-909-9044. (P4)

## VANES

Dura Comp 535, high-quality non asbestos vacuum pump vanes. Good to 400°F. Buy factory direct and save. Same day shipment on most models. Jurop, Battioni, Moro, Masport, Fruitland, Demag. Long lasting Dura-Comp 535 pump vanes carry a "Money-back" guarantee. Call us today. Powerflo Products 800-758-4788 or 562-997-0720. (PBM)

American Industrial Components: Our vanes are manufactured from the highest quality laminated materials available and are fabricated to exact tolerances and specifications. 800-272-7557. (PBM)

## WANTED

WANTED: Nice older Ford toilet truck, stick, Keith Huber or Coleman, preferred no rust, no junk. Call Alex @ 573-864-5597. (P5)

WANTED: Terralift air compressor (Atlas Copco LT/11). Call 803-312-0038; Cell 803-351-9110. (PBM)

Wanted to Buy: Vactor 2100s and late model Guzzlers. Cash. Phone 800-336-4369. (CPBM)

Water jetting equipment. We rent, sell and repair water blasters. Visit us at: [www.waterjettingequipment.com](http://www.waterjettingequipment.com) or phone 714-259-7700. (CPBM)

## WATERBLASTING

For Sale: 2007 325 hp Jet Stream Hydroblasting Pump. 11.5 gpm @ 40,000 lbs. Less than 150 hrs. Tier 3. \$115,000. 925-691-1721. (CP4)

**Gardner Denver** 620-671 Detroit 20K @ 11 gpm. **Gardner Denver** IL450- Volvo 20K @ 17 gpm. **Aquadyne** GA 200 variable speed 3116 CAT 20K, 20 gpm. **Aquadyne** 0450DS-Cummins 20K @ 36 gpm. **Jetstream** 4220-Cummins 20K @ 17 gpm. **Jetstream** UNX-6V53 Detroit 10K @ 26 gpm. **NLB-Ultraclean** Cummins 36K, 7 gpm. **NLB** 10-600 Cummins 10K @ 104 gpm. **NLB** 5-250 Cummins 3600 psi, 182 gpm. **US Jetting Sewer Unit** 4K @ 14 gpm. **Boatman Ind. 713-641-6006.** View @ [www.boatmanind.com](http://www.boatmanind.com). (CPBM)

2002 NLB-4075D diesel, 40,000 psi, 3 gpm, trailer mounted, 300' new hoses, 620 hrs. Perfect condition. Price \$45,000. Contact 973-476-7194. (CP6)

2003 NLB 10-150 electric waterblaster, (0) hours on unit - never used. Marathon Motor on skid. If you want brand new this is it. Priced to sell @ \$32,500. KLM Companies, 617-909-9044. (P4)

NLB 10-250 2000 model year with 1,200 hrs., 250 hp @ 43 gpm. Complete mounted on 1993 International truck with 120,000 miles. Fluid/power end just rebuilt by NLB. In good shape. \$42,500. KLM Companies, 617-909-9044. (P4)

Advertise in Classifieds for only **\$1.00 PER WORD!** at [www.pumper.com](http://www.pumper.com)

Classifieds Category List :: Pumper Magazine

<http://www.pumper.com/classifieds/>

WWW.ONSITEINSTALLER.COM | WWW.PROMONTHLY.COM | WWW.CLEANER.COM | WWW.MSWMAG.COM | WWW.PUMPERTRADER.COM | WWW.PUMPERSHOW.COM

**Pumper** SUBSCRIBE EDITORIAL CLASSIFIEDS VIDEO ADVERTISE

Looking to BUY or SELL?  
Just Submit Your Classified Ad ONLINE!

**It's Easy & Secure!**

**Only \$1.00 PER WORD (\$20 Min.)**

Your ad will be posted on the Pumper Web site within two to three business days after received.

Just go to [www.pumper.com](http://www.pumper.com); click on "Classifieds," click on "Place a Classified Ad;" fill in the online form.

PLACE YOUR AD ONLINE AT [www.pumper.com](http://www.pumper.com) - IT'S ALWAYS THERE TO MEET YOUR BUSY SCHEDULE

By **Scottie Dayton**

## **MICHIGAN: Plan Emerges to Support Michigan Septage Plant**

The Grand Traverse County septage treatment plant in Traverse City, Mich., could cost rural county residents \$40 per year for their septic tank plus a special tax assessment levied on property outside of sewer districts. The county board's proposal would finance the struggling \$8 million facility.

Designers built the plant based on a two-year survey of area haulers that projected 10 million gallons from 23,000 tanks. Instead of pumping the anticipated 10,000 to 12,000 tanks per year, however, requests for service declined and haulers delivered 4.5 million gallons last year. At the plant's present 12 cents per gallon rate, it would need 19 million gallons annually to remain solvent.

Officials say the plant will need at least an extra \$600,000 per year for operations and emergencies. The facility had a tank collapse in 2005, releasing 150,000 gallons of partially treated waste. An independent investigation found thousands of pieces of structural steel missing from three of the four main buildings, design deficiencies, and shoddy workmanship.

## **Michigan Pumper Fined for Illegal Dumping**

A Michigan Superior Court judge found Daniel Laliberte, owner of Dan's Septic Inspection in Candia, guilty of illegally dumping septage and trash across two acres of a Deerfield alfalfa field. He was fined \$30,000, with half of the fine suspended.

Hunters reported the waste in November 2007. A Deerfield police officer, staking out the field two days later, witnessed a gray line of liquid coming from Laliberte's 4,200-gallon vacuum truck. Department of Environmental Services inspectors found debris consistent with septage waste in the field. Last year, a judge prohibited farm owner Stephen Sanborn from harvesting alfalfa or allowing people in the field for three years.

State regulations allow septage dumping on farmland when permitted with public notice and treatment for pathogens. Laliberte's hauler's license was due for renewal at the time of the trial. The DES intends to renew it. However, a further violation within three years could reinstate the suspended \$15,000 fine.

## **CALIFORNIA: Delayed Septic System Regulations Shelved Again**

A long-delayed state law instituting more stringent onsite system requirements and mandating septic system inspections every five years hit another snag Jan. 30 when public comment hearings were postponed because of complaints from homeowners and businesses. The State Water Resources Control Board Division of Water Quality suspended several months of planned workshops to explain Assembly Bill 885. Critics complained the new regulations, crafted first in 2000, could be costly to more than a million households that have septic systems.

As the review period began, members of the California Onsite Wastewater Association hosted community workshops to inform resi-

dents about the state's new septic system code. If the rules pass as planned for 2010, septic tanks would need to be inspected for solids accumulation every five years. Qualified professionals would determine if onsite systems within 600 feet of the Pacific Ocean, Malibu Creek, or Malibu Lagoon were contributing to their impairment.

The proposed regulations would require site assessments for new systems including determination of seasonal high groundwater. They would need to be built by licensed contractors or property owners, and those within 600 feet of impaired water would need supplemental treatment.

Affordability and feasibility were COWA's main concerns. Members said some regulations were too strict and the standards were difficult to obtain by any system. The association will continue working with regulators to revise the requirements.

## **HAWAII: Decentralized Plants Gain Acceptance**

The Hawaii Wastewater Reclamation Division of the Department of Environmental Management granted zoning for developing Honua'ula in South Maui, provided a private decentralized treatment plant that could produce R1 effluent (approved for most uses except drinking) would be built.

The effluent would be used for irrigation. WSI International LLC in Honolulu would probably provide the plant. The company sells package plants for large and small (as few as 20 homes) developments and is introducing single-family units to replace septic systems. They require no drainfields.

## **OHIO: State Association Looks to Expand Training**

The Ohio Onsite Wastewater Association joined with the National Association of Wastewater Transporters Inc. to offer a train-the-trainer course to certify participants to teach onsite installer courses. NAWT instructors teach the material and a trainee teaches it the next time the course is offered with NAWT instructors monitoring and assisting. The two-day course can be broken into shorter ones for more flexibility. The state association is looking for at least two trainers from each region to minimize travel requirements. Contact Susan at 866/843-4429 or oowa@ohioonsite.org.

Tim Frank of Tim Frank Septic Tank Cleaning Co. in Huntsburg received the association's 2009 Distinguished Service Award.

## **ONTARIO: OASIS Presents Awards**

The Ontario Association of Sewage Industry Services honored Robert Murrell of Pepi Sewage in Port Severn with its 2008 Lifetime Achievement Award. Jamie Delaney, waste management manager for the District of Muskoka, received the Robert Noble Award for contributing to the success of the OASIS Rural Wastewater Expo for two years. The Appreciation Award went to Jeff Cheshier of Buckhorn Sand & Gravel for helping a fellow association member.

## **TEXAS: Changing Provider Code**

Maintenance providers with Installer II or Wastewater C licenses will not be required to take an advanced aerobic course and pass the maintenance provider examination to retain state certification. On the recommendation of the Texas Onsite Wastewater Association, the regulatory commission amended restrictions, provided individuals were registered maintenance providers when the rules became effective last September.

# Training & Education

## National Association of Wastewater Transporters Inc.

NAWT has scheduled sessions in the following locations:

- June 12 – Vacuum Truck Technician, Monterey, Calif.
- June 16 – Inspector Recertification Training, Flagstaff, Ariz.
- Aug. 25-26 – Inspector Training, Flagstaff, Ariz.
- Sept. 16-17 – Waste Treatment Symposium, Orlando, Fla.
- Sept. 29-30 – Inspector Training, Arizona.
- Oct. 9-10 – Waste Treatment Symposium, Orlando, Fla.
- Oct. 15-16 – Onsite Inspector Training and Certification, San Luis Obispo, Calif.

Call NAWT at 800/236-6298 or visit [www.nawt.org](http://www.nawt.org). For Arizona classes, contact Kitt Farrell-Poe at 928/782-3836 or e-mail [kittfp@ag.arizona.edu](mailto:kittfp@ag.arizona.edu).

## Alabama

Licensing classes are the joint effort of the Alabama Onsite Wastewater Association and University of West Alabama. Courses are at the UWA Livingston campus:

- May 6-8 – Basic Installer
- May 13-15 – Advanced Level II Installers
- June 3-5 – Basic Installer
- June 25-26 – Continuing Education, Dothan
- July 9-10 – Pumper
- July 29-31 – Basic Installer

Call 334/396-3434 or visit [www.aowa.org](http://www.aowa.org).

## California

The training schedule for the California Onsite Wastewater Association is:

- May 8 – Science of Soils and Onsite Wastewater Disposal, (location to be determined)
- June 12 – NAWT Vacuum Truck Technician, Monterey
- July 24 – Science of Soils and Onsite Wastewater Disposal, San Luis Obispo

Call MaryAnne Bobrow at 916/727-2692 or e-mail [maryanne@cowa.org](mailto:maryanne@cowa.org).

## Minnesota

The University of Minnesota Extension has these classes:

- May 4-5 – Pumping/Maintenance, Mankato
- May 4-5 – Service Provider, Mankato
- May 20-21 – Soils, Owatonna
- May 27-28 – Inspecting Onsite Systems, Waseca
- June 2-5 – Advanced Design and Inspection of Onsite Systems, St. Cloud
- June 9-11 – Basic Design of Onsite Systems, Brainerd
- June 12 – Soils Continuing Education, Cloquet
- June 16-17 – Inspecting Onsite Systems, Waseca
- June 18-19 – Soils, St. Cloud
- June 25 – Soils Continuing Education, Pipestone

Call Nick Haig at 800/322-8642 (612/625-9797) or visit <http://septic.umn.edu>.

## C A L E N D A R

### April 3-4

Alabama Onsite Wastewater Association Annual Trade Show, Pelham Civic Complex, Pelham. Call 334/396-3434 or visit [www.aowa.org](http://www.aowa.org).

### April 6-9

National Onsite Wastewater Recycling Association Technical Exhibition and Conference, Midwest Airlines Convention Center, Milwaukee. Call 800/966-2942 or visit [www.nowra.org](http://www.nowra.org).

### Aug. 5-8

Florida Onsite Wastewater Association Conference, Ocean Center, Daytona Beach. Call 407/830-4381 or [www.fowaonsite.com](http://www.fowaonsite.com).

### Aug. 28-29

Georgia Onsite Wastewater Association Conference, Marietta Conference Center, Marietta. Call 678/646-0379 or visit [www.onsitewastewater.org](http://www.onsitewastewater.org).

### Oct. 20-21

Delaware Onsite Wastewater Recycling Association Technical Conference, Dover Downs Hotel and Casino, Dover. Call Ben Miller at 302/226-2844 or visit [www.dowra.org](http://www.dowra.org).

### Oct. 22-23

Ontario Association of Sewage Industry Services Rural Wastewater Treatment Expo, Hamilton. Call 877/202-0082 or visit [www.oasisontario.on.ca](http://www.oasisontario.on.ca).

## Missouri

The Missouri Smallflows Organization is offering these CEU courses:

- May 6 – Onsite Pumps, Panels and Electrical, Chillicothe
- May 19-20 – Operation and Maintenance, Liberty

Call 417/739-4100 or visit [www.mosmallflows.org](http://www.mosmallflows.org).

## New England

The New England Onsite Wastewater Training Program at the University of Rhode Island in Kingston has these workshops:

- May 5-6 – Inspecting Onsite Systems
- May 14 – Innovative and Alternative Technology Overview
- May 28 – Innovative and Alternative Technology (Fieldwork at Peckham Farm)
- June 2-3 – National Operation and Maintenance Service Provider Program
- June 11 – INSP200 Examination
- June 25 – Bottomless Sand Filter Design and Installation
- June 25 – Soil Basics

Call 401/874-5950 or visit [www.uri.edu/ce/wq](http://www.uri.edu/ce/wq). Contact Mark Stolt at 401/874-2915 or [mstolt@uri.edu](mailto:mstolt@uri.edu).

## New York

The New York Onsite Wastewater Treatment Training Network Inc. is offering Alternative Onsite Wastewater Treatment Technology courses May 27-28 in Skaneateles. Call SUNY Delhi at 800/963-3544 or visit [www.delhi.edu/bcs/otn\\_wastewater](http://www.delhi.edu/bcs/otn_wastewater).

## Virginia

The following courses by the Virginia Onsite Wastewater Recycling Association (VOWRA) and Virginia Center for Onsite Wastewater Training (VCOWT) are at Blackstone unless stated otherwise.

# Industry NEWS

- May 11-15 – Soils Exploration (VCOWT)
- May 13 – Proprietary System Training (VOWRA)
- May 13-14 – Wastewater 101 (VCOWT)
- June 1-5 – Onsite Design Camp II (VCOWT)
- June 3 – A to Z of Onsite Wastewater, Charlottesville (VOWRA)
- June 3-4 – Effluent Dispersal Systems (VCOWT)
- June 17 – Proprietary System Training (VOWRA)

For VCOWT classes, contact Debbie Campbell at 434/736-2011 or visit [www.southside.edu/programs/wastetreat](http://www.southside.edu/programs/wastetreat). For VOWRA courses, contact Jeff Barr at 703/771-5250 or visit [www.vowra.org](http://www.vowra.org).

## Washington State

The Washington On-Site Sewage Association and Washington State Department of Health in cooperation with Washington State University are offering these certification courses at the training center in Puyallup unless stated otherwise:

- April 8 – Maintenance Basics
- April 15 – Pumper 101
- April 22 – Designers: Subsurface Drip Systems
- May 6 – Electrical Basics
- May 7 – Control Panel Wiring
- May 13 – Basics of Installing, Part 3
- May 20 – Maintenance Basics, Bremerton

Call WOSSA at 253/770-6594 or visit [www.wossa.org](http://www.wossa.org).

*Pumper invites your state association to post notices and news items in this column. Send contributions to [editor@pumper.com](mailto:editor@pumper.com). ■*

## United Site Services Acquires Fogie's Septic Clean

United Site Services has acquired Fogie's Septic Clean of Sykesville, Md. The acquisition increases USS's presence in the Baltimore-Washington, D.C., area and extends its service to Frederick, Md.

## ECN/KORNS Names Herman Plant Manager

ECN/KORNS, manufacturer of galvanized couplings, elbows, clamps and nipples, has promoted Paul Herman to plant manager of its Avinger, Texas, facility.

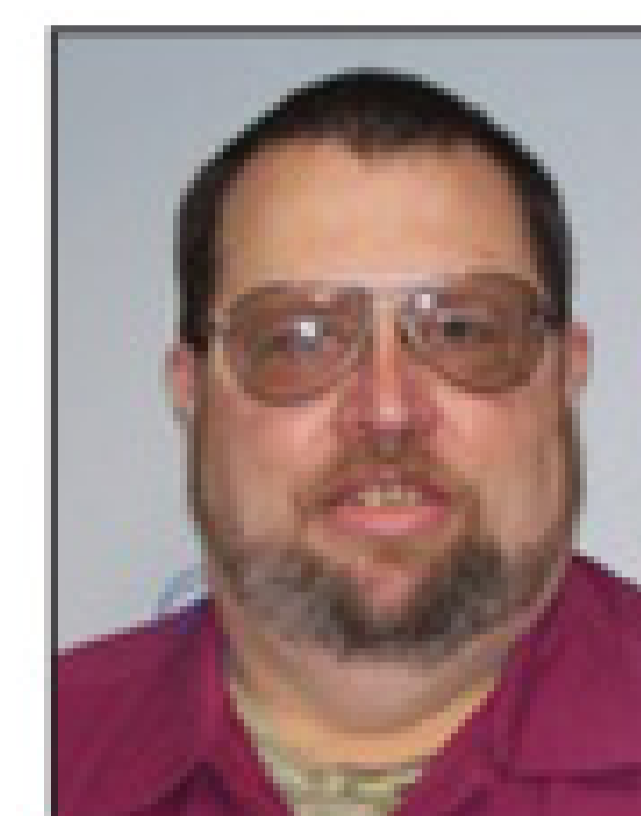

Paul Herman

## Cloverleaf Tool Names Rawlings General Manager

Kevin Rawlings has been promoted to general manager for Cloverleaf Tool Co. Rawlings has 12 years experience in sales, marketing and distribution.

## Wieser Chosen Corporate Safety Award Finalist

Wieser Concrete Products Inc., Maiden Rock, Wis., has been chosen as a finalist for the 2008 Wisconsin Corporate Safety Award. The selection is based on the company's low lost-time injury rate for the past three years. Two Wieser facilities marked two-year, accident-free milestones in 2008 and another marked one year accident-free.

## Trowbridge Wins Hur Chemical Drawing

John Trowbridge of Ram Power Environmental was the grand prize winner of the Hur Chemical Mfg. Pumper Show Drawing. He received two roundtrip airline tickets. Jim Jansen of Jim's Johns Inc. won free restroom deodorizer and Mark Clemons of AGENCO/TMCC won \$100. ■

**Everyone  
talks about  
creating a  
greener  
environment.**

*You actually do it.*

Find the tools you need to keep  
your communities **green** at  
[www.colepublishing.com](http://www.colepublishing.com).

*Publishing environmental trade magazines since 1979.*



## "Duel Power Lid"

Plugs, Lids & Adaptor Rings

Sizes Available: **18", 24",  
30" & 36"**



**Fergus Power Products**  
Providing "Environmental Products"

*The Company who maintains a pulse on the environment!*

Toll Free **1-800-243-7584**  
E-mail [fpproducts@prtcl.com](mailto:fpproducts@prtcl.com)  
[www.FergusPowerProducts.com](http://www.FergusPowerProducts.com)



**Old Pueblo Septic and Drain Service Inc.**  
Tucson, Ariz.  
George Smith and Amy Deight  
Founder 1986  
Employees 15  
Service: Residential septic and drain cleaning  
Service Area: Most of Tucson  
Service Area: Most of Tucson  
Old Pueblo Septic and Drain Service Inc. has been serving the Tucson area since 1986. We are a family-owned and operated business that provides professional septic and drain cleaning services to residential and commercial customers. Our technicians are trained and certified, and we use the latest equipment and techniques to ensure the highest quality of service. We are proud to be a part of the Tucson community and to provide reliable, honest, and affordable service to our customers.

### IN GOOD HANDS

Evaluate the lessons and understanding of the business needed to an elderly family ownership transfer for Old Pueblo Septic and Drain Service  
By Dan Stewart

George Smith and Amy Deight, founders of Old Pueblo Septic and Drain Service Inc., have been successful in building a family-owned business that has thrived for over 30 years. Their success is a testament to their hard work, dedication, and understanding of the business. They have built a strong reputation in the Tucson area and have a loyal customer base. Their business is a family-oriented business, and they have successfully transferred ownership to the next generation. This is a great example of how a family business can thrive and grow over time.

### Separation ANXIETY

Water Tech owners build their own custom solution offering simplicity and significant disposal cost savings  
By Scott Dayton

Water Tech owners build their own custom solution offering simplicity and significant disposal cost savings. The company has developed a proprietary technology that allows for more efficient water treatment and disposal. This has resulted in significant cost savings for their customers, while maintaining high quality and reliability. The company's focus on simplicity and cost-effectiveness has been a key factor in their success.

### ACCIDENT-BARGAIN

As a water treatment technology company, Water Tech has developed a unique solution for water treatment and disposal. This technology allows for more efficient and cost-effective water treatment, resulting in significant savings for customers. The company's focus on simplicity and cost-effectiveness has been a key factor in their success.

### REDUCE WATER WASTE

Water Tech's innovative technology has revolutionized the way we think about water treatment and disposal. By using their proprietary technology, customers can significantly reduce water waste and disposal costs. This is a great example of how innovation can lead to significant cost savings and environmental benefits.

### TECHNICAL SUPPORT

Water Tech provides excellent technical support to all of its customers. Their experienced technicians are trained in the latest equipment and techniques, ensuring that customers receive the highest quality of service. Their focus on customer satisfaction has been a key factor in their success.

### COVER STORY

Water Tech's innovative technology has revolutionized the way we think about water treatment and disposal. By using their proprietary technology, customers can significantly reduce water waste and disposal costs. This is a great example of how innovation can lead to significant cost savings and environmental benefits.

### REPRINTS AVAILABLE

Visit [pumper.com/editorial](http://pumper.com/editorial) for articles and pricing for articles and pricing  
E-mail [jeffl@colepublishing.com](mailto:jeffl@colepublishing.com) or call 800-257-7222

### Make the most of it!

Water Tech's innovative technology has revolutionized the way we think about water treatment and disposal. By using their proprietary technology, customers can significantly reduce water waste and disposal costs. This is a great example of how innovation can lead to significant cost savings and environmental benefits.

### REPRINTS AVAILABLE

Visit [pumper.com/editorial](http://pumper.com/editorial) for articles and pricing  
E-mail [jeffl@colepublishing.com](mailto:jeffl@colepublishing.com) or call 800-257-7222

### ON TOP OF NEW TECHNOLOGY

Water Tech's innovative technology has revolutionized the way we think about water treatment and disposal. By using their proprietary technology, customers can significantly reduce water waste and disposal costs. This is a great example of how innovation can lead to significant cost savings and environmental benefits.

### ON TOP OF NEW TECHNOLOGY

Water Tech's innovative technology has revolutionized the way we think about water treatment and disposal. By using their proprietary technology, customers can significantly reduce water waste and disposal costs. This is a great example of how innovation can lead to significant cost savings and environmental benefits.

### ON TOP OF NEW TECHNOLOGY

Water Tech's innovative technology has revolutionized the way we think about water treatment and disposal. By using their proprietary technology, customers can significantly reduce water waste and disposal costs. This is a great example of how innovation can lead to significant cost savings and environmental benefits.

### ON TOP OF NEW TECHNOLOGY

Water Tech's innovative technology has revolutionized the way we think about water treatment and disposal. By using their proprietary technology, customers can significantly reduce water waste and disposal costs. This is a great example of how innovation can lead to significant cost savings and environmental benefits.

### Tanks Look

Water Tech's innovative technology has revolutionized the way we think about water treatment and disposal. By using their proprietary technology, customers can significantly reduce water waste and disposal costs. This is a great example of how innovation can lead to significant cost savings and environmental benefits.

### Tanks Look

Water Tech's innovative technology has revolutionized the way we think about water treatment and disposal. By using their proprietary technology, customers can significantly reduce water waste and disposal costs. This is a great example of how innovation can lead to significant cost savings and environmental benefits.

# The Clear Choice!

effluent filters

**POLYLOK**<sup>™</sup> Inc.

**BEST**  
TECHNOLOGY



Zabel®  
A Division of Polylok Inc.



*See why we consistently beat the competition!*  
**Our filters...**

- 1 Cannot be installed incorrectly.
- 2 Will not allow direct bypass.
- 3 Have a patented Shut-Off Ball that prevents solids from leaving the tank during servicing.
- 4 Have a unique design that prevents premature clogging.
- 5 Are rated for 800 GPD to 10,000 GPD.
- 6 Accept Smart Filter® Alarm to notify homeowner when the filter needs servicing.
- 7 Are ideal for septic, grease traps and advanced treatment systems.

*Filters play a critical role in protecting the septic system leach field. To ensure your system is designed and protected properly, insist on Polylok and Zabel Filters. We have been the Clear Choice since 1959!*

*See our complete line of Effluent Filters at [www.polylok.com](http://www.polylok.com)*



Zabel®  
A Division of Polylok Inc.

**BEST**  
TECHNOLOGY

**POLYLOK**<sup>™</sup> Inc.

*Innovations in Precast, Drainage & Wastewater Products*



Made In The U.S.A.

3 Fairfield Blvd,  
Wallingford, Connecticut 06492  
1-800-701-3942 Fax: 203-284-8514  
email: [sales@polylok.com](mailto:sales@polylok.com)  
Web site: [www.polylok.com](http://www.polylok.com)

# You Built It... ...You Name It!

## YOU TALKED...WE LISTENED

Four years of your feedback inspired the design of our new portable restroom unit. So, we'll ask you for your input again...

What should we name it?

Visit [www.polyjohn.com](http://www.polyjohn.com)

to submit a name for our *new* portable restroom unit.

If your idea is selected

...you win one!



## New from PolyJohn

- Durable
- Stylish
- Roomy
- Easy to Maintain
- Affordable

**Innovative Products ~ Knowledgeable People**



there when you need us  
[www.polyjohn.com](http://www.polyjohn.com)  
800.292.1305

**\$379 PolyJohn's NEW Portable Restroom Unit\***

### KNOCKOUT SPECIAL

Take advantage of our special offer on our newest product!

\*Price does not include assembly, freight, or applicable taxes. F.O.B. Whiting, IN

Offer expires 4/30/09

800-292-1305 • [polyjohn.com](http://polyjohn.com)



# **/// PRESVAC**

DESIGNED AND BUILT FOR PERFORMANCE

## **Bright Finish Aluminum Tanks**

for the Septic Pumping Industry...  
Standard tank models from  
2,000 gallons to 5,000 gallons.



## **Hydro-Trencher**

5300 CFM air flow/28" HG vacuum with 8" hydraulic actuated boom, 3000 U.S. gal. stainless debris tank, 1000 U.S. gal. stainless water tank, 9 G.P.M. water pump with pressures to 5800 p.s.i.

## **Powervac 5300 for Wet/Dry Operation**

5300 CFM air flow/28" HG vacuum,  
Dump chutes extended to rear of truck,  
Stainless steel 316, DOT 407/412



## **Liquid Truck - DOT 407/412**

Designed for industrial liquid applications

# **/// PRESVAC**

4131 Morris Drive  
Burlington, Ontario, Canada L7L 5L5  
Fax: 905-681-0411

Nationwide Sales & Service

**905-637-2353 • 800-387-7763**

[www.presvac.com](http://www.presvac.com)