

Vacuum Trucks & Spring Maintenance

DEDICATED TO THE LIQUID WASTE INDUSTRY

Pumper

March 2009 www.pumper.com \$5.00 U.S.

It's Time to Kick the Tires

Prep the fleet for busy season

PAGE 58

Firing ON ALL CYLINDERS

Truck talk is on tap with Maine pumper Nathan Gay

PAGE 36

COLE PUBLISHING INC.
1720 MAPLE LAKE DAM RD.
PO BOX 220
THREE LAKES WI 54562

CHANGE SERVICE REQUESTED

PRSTD STD
U.S. POSTAGE
PAID
PERMIT NO. 659
Bolingbrook, IL

GOT AN EMERGENCY?



CALL THE DOCTOR!

20 New Trucks In Stock!

- Trucks
- Tanks
- Parts
- Service
- Pumps

RESTROOM & SEPTIC

TRUCK DOCTOR
800-328-3332

*Speak Directly With Our Experts About A
Replacement Truck, Parts Or Advice On Repairs.*



www.satelliteindustries.com



Imagine The Possibilities

Masport®

It was good to see you in
Louisville.

We're Extending our Show Discounts!

Save more on Masport Products through March 31, 2009.



HXL400WV Plug & Play

400 CFM



High Vacuum Blower Plug & Plays

494 to 912 CFM

**Ask your local distributor about our extended
show special discounts.**



HXL4V Plug & Play

160 CFM

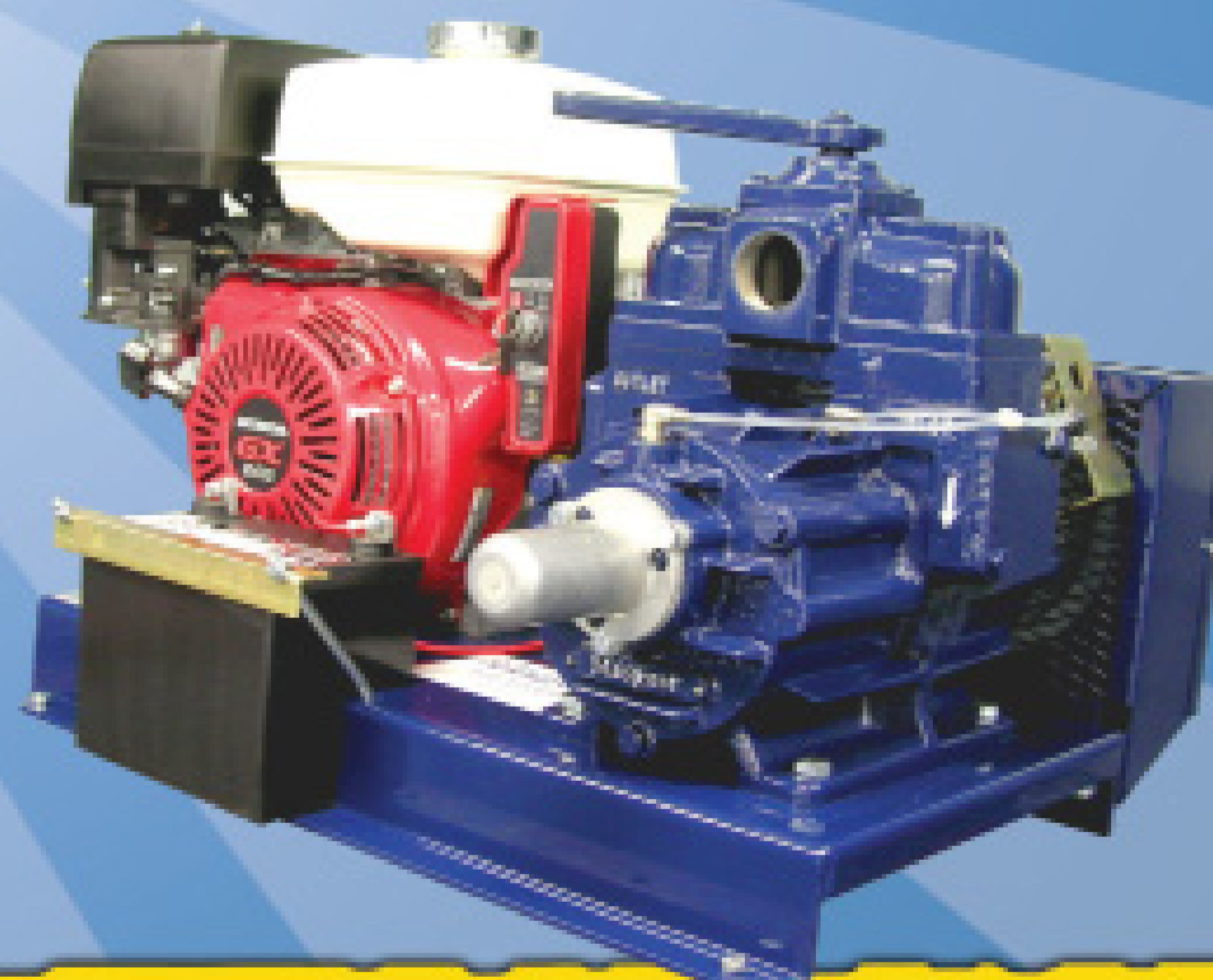

Engine Driven Systems

5 to 24 Horsepower

www.masportpump.com

Toll Free 1-800-228-4510

There's a Lot Going On 'After Hours'



By Jim Kneiszel, Editor

Last August, we kicked off a new feature in *Pumper* called "After Hours," seeking to find out what readers do when they don't have a vacuum hose in hand. I wasn't sure what to expect, but I had a hunch that a lot of contractors are involved in interesting hobbies, charitable ventures and civic projects in their home communities.

Let's just say the reward has been well worth the risk of starting the new feature. As it's turning out, pumpers are a well-rounded lot. The first "After Hours" stories have produced a fascinating group of small business professionals who show perseverance, special talents and plain old gumption in their off-the-clock endeavors.

Here's a brief review of the folks we've met so far:

- **Alexandra Townsend** is manager of regional sales and marketing at the Washington, D.C., office of A Royal Flush. But she's also a marathon runner who showed gritty determination in going the distance in the New York City Marathon late last year.

- **Carol Coddington** ran K and C Septic Services, Huntington County, Pa., with her husband, Keith, for many years. But when she retired recently, she got into gardening in a big, big way. And now her hobby is in full bloom.

- **Tim Kettler** is owner of Action Septic Service in Warsaw, Ohio, with his wife, Roberta. He's also been a Green Party candidate for Ohio's secretary of state and, last fall, the State Senate. For the record, he lost, but remains interested in politics.

- **Danny Bland** is owner of Bland's Sewer and Water in Alton, Ill. But every December, the white-bearded gentleman is known as Santa Claus to thousands of people, young and old, in southern Illinois.

- **Robb Barnes** is owner of King's Pumping Service in Dallas, Ore. He's also an egg and beef farmer who's working toward a "certified organic farm" designation for his operation.

- **Rodney Upton** owns Hero Septic in Athens, Ga. He's also studying to become an ordained minister in the Reformed Presbyterian Church in the United States and hopes to one day both pump and preach.

And in this issue, we meet **Dave Neelis**, owner of Dave's Sewer Service, Waupaca, Wis. As you'll read, Neelis has a healthy — or his wife might tell you it's unhealthy — obsession with his backyard hockey rink.

I want to thank each of these contractors for giving us a glimpse into their lives outside of the pumping profession. I'm sure they've poured heart and soul into making their small businesses a success. It's truly remarkable that they find the time and maintain the enthusiasm for these interesting extracurricular activities.

To me, these stories reinforce the dynamic and diverse qualities of the people who work in the liquid waste industry. There is definitely more to a pumper than meets the customers' eyes. Sure, they're dedicated to doing a job critical to a clean environment. But there's more to the story.

What's your "After Hours" story? Drop me a line at editor@pumper.com and tell me about your projects or passions. I'd love to share your story with the rest of the *Pumper* community. ■

Contact us: *Pumper* strives to serve the liquid waste industry with interesting and helpful stories. We welcome your comments, questions and column suggestions and promise a prompt reply to all reader contacts. Call 800/257-7222; fax 715/546-3786; e-mail *Pumper* editor Jim Kneiszel at editor@pumper.com.

Sanitation Station
"Commercial Quality" Running Water Restroom
DropBox

No out of pocket expense
Immediate revenue generation
New product to your rental fleet without a major investment

Three business model offers with the Sanitation Station are:

OPTION 1
• You buy it!
• You rent it!
• You pump it!

OPTION 2
• You have a six month minimum rental...
• We rent the unit to you at a discounted rental rate...
• You mark the unit up and re-rent it to your customer...
• You enjoy the revenue from pumping the unit...

OPTION 3
• You have a six month minimum rental...
• Call DropBox and we land the business for you...
• We rent the unit to your customer...
• You enjoy the revenue from pumping the unit...

DROP BOX
1.888.388.7768
www.dropboxinc.com

Lenzyme
Solutions for all Waste & Grease Problems

NEW Drainfield Business Builder

BEST PACKAGING - BEST PRODUCTS - BEST PRICE

Discover Marketing Secrets to More Pump-Outs
1-800-223-3083
Call Today for Your **FREE** Sample

TRAP-CLEER **LENZYME** **ROOTX**

HOUSE OF IMPORTS TRUCK SALES

▶▶ SINCE 1947

FAX: 305.691.4779

▶▶▶ WWW.HOUSE-OF-IMPORTS.COM

CALL ANGEL AT:
786.258.3384
OR
305.691.4778

PUMPER STIMULUS: \$5000 CASH BACK WITH PURCHASE!



2005 PETERBILT 379

5000 GAL., THANKS TO B&H - 5TH PURCHASE!



2000 FREIGHTLINER

3600 GAL., CAD 450 H.P., 10 SPD

NOW AVAILABLE



NOW AVAILABLE

2002 INTERNATIONAL

3600 GAL., 450 H.P., 10 SPD



NOW AVAILABLE

2005 MACK

4200 GAL., AVAILABLE



THANK YOU



2001 INTERNATIONAL

2005 FREIGHTLINER

2004 PETERBILT

ALL 3 IN PROGRESS, AVAILABLE SHORTLY

3 IN PROGRESS - CALL FOR DETAILS

100,000 MILE LIMITED FACTORY WARRANTY

▶ DELIVERY ▶ EXPORT ▶ PUMP WARRANTY: 1 YEAR ▶ TANK WARRANTY: 5 YEARS



ARTICLES

36
Firing On All Cylinders
- Mary Shafer

On the cover: Matt Chadbourne assists A-1 Environmental Services owner Nathan Gay as they use a Kenworth T800 vacuum truck with 3,600-gallon Presvac tank to pump an oceanside resort in Maine. (Photo by Kelly Roy)

4
Reading Between the Lines: There's a Lot Going On 'After Hours'
- Jim Kneiszel

10
Letter to the Editor

18
Building the Business: Create a Reminder Card System
A simple-to-organize postcard mailing generates sales and stabilizes both workflow and cash flow.
- Robb Barnes

26
Rules and Regs: Michigan Grapples with Required Inspections, Diminished Land Spreading
- Scottie Dayton

44
Covering the Bases
Do-all Missouri-based All Star Septic manufactures the tanks, installs the systems, pumps the waste and places portable restrooms at construction sites.
- Mary Shafer

50
After Hours: Playing Hookey Means Playing Hockey
When the pumping business slows in the dead of the Wisconsin winter, Dave Neelis trades his vacuum hose for skates and drops the puck on his personal ice rink.
- Judy Kneiszel

58
Spring Maintenance: It's Time to Kick the Tires
As you gear up for another busy season, make sure your service fleet has plenty of rubber to meet the road.
- Tim Miller

70
Overheard Online: Customer Wants to Flip His Lid
The pumper tells a homeowner that a riser in a cold northern climate will slow bacterial action in the tank ... Is he right?

78
Safety First: Too Extreme? Or About Time?
The National Safety Council proposes a blanket ban on cell phone use while driving.
- Ted J. Rulseh

114
Legal Advisor: Protecting Your Great Invention
Follow these steps to give your latest great contraption or gizmo quick, easy and inexpensive patent protection.
- Fred S. Steingold

REGULAR FEATURES

64
Money Manager: Buy Your Competitor?
The purchase of another company in your field can be a quick way to expand, but you have to proceed with due diligence.
- Erik Gunn

74
Industry News

82
Classy Truck of the Month
We feature Kerkstra Septic Tank Cleaning Inc., Hudsonville, Mich.

86
Reader Pipelines: Truck and Driver
Proper training will help truck drivers protect themselves from injury and the expensive equipment they operate.
- Mary Shafer

94
Septic System Answer Man: Just Say No to Garbage Disposers
The Answer Man's simple advice to homeowners and onsite maintenance pros: "Do not deposit anything into the septic tank unless you have eaten it first!"
- Roger E. Machmeier, Ph.D

98
NAWT News: Plans for 2009 Advance Education and Business Opportunities
- Tom Ferrero

116
Product News In the Spotlight: Accent Manufacturing IFRS Separator

120
Association News; Training and Education; Calendar

Coming in April

Special Issue: PORTABLE SANITATION

- New products and technology at the 2009 Pumper & Cleaner Expo
- After Hours: Texas portable restroom operator moonlights as a bail bondsman
- Septic System Answer Man: Sludge 101 course informs newer pumpers

Pumper

DEDICATED TO THE LIQUID WASTE INDUSTRY

www.pumper.com

Published monthly by

COLE publishing

Celebrating 30 years of publishing.
1979-2009

COLE Publishing Inc.
1720 Maple Lake Dam Rd.
PO Box 220
Three Lakes WI 54562

© Copyright 2009 COLE Publishing Inc.
No part may be reproduced without permission of the publisher

In U.S. or Canada call toll-free 800-257-7222
Elsewhere call 715-546-3346
E-mail: info@pumper.com
Web site: <http://www.pumper.com>
Fax: 715-546-3786

Office hours 7:30 a.m. - 5:00 p.m.
Central Time, Monday - Friday

SUBSCRIPTION INFORMATION: A one year (12 issue) subscription to *Pumper* in the contiguous 48 U.S. states costs \$16 (24 issues for \$26; 36 issues for \$36). Subscriptions to Canada or Mexico cost \$28 per year (24 issues for \$54). Subscriptions to all other foreign countries cost \$82 per year. Subscribers are guaranteed monthly delivery of the magazine. To subscribe, send company name, mailing address, phone number and check or money order (U.S. funds payable to COLE Publishing Inc.) to the address above. MasterCard, VISA and Discover are also accepted. Supply credit card information with your subscription order.

Our subscriber list is occasionally made available to carefully selected companies whose products or services may be of interest to you. Your privacy is important to us. If you prefer not to be a part of these lists, please contact Kayla at kaylaw@colepublishing.com.

CLASSIFIED ADVERTISING: RATE: \$1.00 per word, per month. Minimum of 20 words or \$20. All classified advertising must be PAID IN ADVANCE. DEADLINE: Classifieds must be received by the first of the month for insertion in the next month's edition. PHONE-IN ADS ARE NOT ACCEPTED. Ads may be faxed only when charging to MasterCard, VISA or Discover. Please supply all credit card information with faxed ads. Be sure to include your phone number (with area code) in your ad. Make checks payable to COLE Publishing Inc. and mail with classified ad to the address above. CLASSIFIED ADVERTISING APPEARS NATIONWIDE AND ON THE INTERNET. Not responsible for errors beyond first insertion.

DISPLAY ADVERTISING: Call 800-994-7990 and ask for Jim, Kim, Winnie or Phil. Publisher reserves the right to reject advertising, which in its opinion is misleading, unfair or incompatible with the character of the publication.

CIRCULATION: Circulation averages 26,071 copies per month. This figure includes all circulation regions (nationwide) and international distribution.



PUMPER & CLEANER ENVIRONMENTAL EXPO INTERNATIONAL

Education Day:
February 24, 2010

Exhibits Open:
February 25-27, 2010

Kentucky Exposition Center
Louisville, Kentucky
www.pumpershow.com



Presenting The **NEW** Moro Vacuum Pumps From **MORO USA**

PM60A
233 cfm

PM70A
300 cfm

PM80
379 cfm



*Thank you for visiting us
in Louisville*



*Ask for a quality Moro pump from your truck
builder, or call us for the dealer nearest you.*

Pittsburgh, PA | 1-800-383-6304 | fax 412-269-4172 | www.morousaeast.com | moroeast@attglobal.net
St. Louis, MO | 1-866-383-6304, 636.584.8844 | fax 636-583-2044 | www.morousaeast.com | moro@charter.net

ADVERTISER index

March 2009

27th Trucks Inc.54

A

A & L Systems Inc.22



Abbott Rubber Co. Inc.24



Abernethy Welding & Repair 48
Accent Manufacturing.....118



Acro Trailer Company30
Alpha Mobile Solutions.....12
Altarnamats16
American Machine & Tool90
Anchor Graphics Inc.118
Aqua Ben Corp.70



Aqua-Zyme Disposal Sys.....54



Arcan Enterprises Inc.16



ARMAL Inc.29



Armstrong Equip.13, 30, 72
Art's Truck & Equipment....119
Atlanta Rubber & Hyd.90

B

Badger Vacuum Trucks.....56
Baker's Waste Equipment....22
Balzer Inc.....80
Bandlock Corp.24
Best Enterprises Inc.69
Brenlin Co. Inc.....80



Bright Technologies74

C



Cam Spray117
Cape Cod Biochemical59
Capital Partners LLC.....32

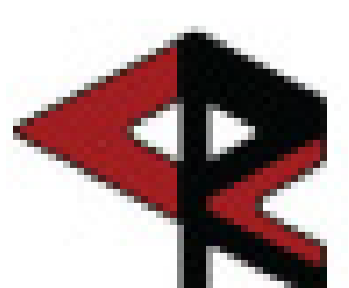

Capital Rubber Corp.66

C

Center Capital Corp.60



Chandler Equipment Inc. 9, 11
Chempace Corporation.....10
Circle D Truck Sales52

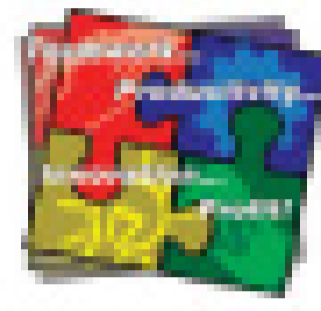

Clear Computing Inc.90



Comforts of Home Services 82
Cook Compression Group ..93



Crust Busters/Schmitz Bros.10

D

Del Vel Chemical Co.68
Denver Truck Sales.....74
Diller Equipment.....12
Dragon Products14-15
Drop Box Inc.4

E

Ecological Laboratories119



Elastec/American Marine52
EnviroTub97
Erickson Tank & Pump42

F



F. S. Solutions.....75
Fergus Power Pump Inc.59



Flo Trend Inc.34
Fruitland Tool & Mfg.40

G

Gamajet Cleaning Sys.53
GapVax Inc.85
Granite Leasing Co.68
Green Way by PolyPortables 65
Guzzler Mfg. Inc.48

H

Hampel Corp.79
Hannay Reels32

H

Hedstrom Plastics40
House of Imports5
Hull's Truck Bodies96

I

Imperial Industries Inc.25

J



J&J Chemical Co.81



JAG Mobile Solutions16

K

KeeVac Industries Inc.91
Kentucky Tank Inc.34
Key Commercial Corp.76
KMH Equipment Inc.88

L

L.C. Tanks.....61
L.M.T. Inc.80
Lane's Vacuum Tank Inc.92



Lely Manufacturing Inc.12
Lely Waste Solutions28



Lenzyme-Trap-Cleer Inc.....4
Longhorn Tank & Trailer Inc. 42

M



Marsh Industrial27



Masport Inc.3
McKee Technologies Inc. ..115
Michigan Vacuum Truck87
Mid-Continent Truck Sales ..99
Mid-State Tank Co. Inc.92
Milwaukee Rubber Prod.96



Moro USA East Inc.7

N

National Truck Center17
National Vacuum Equip.95



NuConcepts42

P



Pik Rite Inc.67
PolyJohn Enterprises123
Polylok Inc.....122
PolyPortables Inc.20-21
PowerFlo Products Inc.49



Pressure Lift Corp.115
Presvac Systems Ltd.....124
Prime Solution Inc.....32
ProSept Protection Plan88

R

RA Ross N.E.76
Reelcraft Industries Inc.19
Rich Mobile Restrooms97



Ritam Technologies LP.....76
Robinson Septic Service88
RotoSolutions Inc.118
RouteOptix Inc.....96
Rush Refuse Systems33

S

Satellite Industries2, 62-63



Septic Services Inc.56
Simple Solutions97
Smithco Mfg. Inc.....93
Specialty B Sales60
Spectrum Environmental114
Standard Equipment Co.22
Stellar Industries Inc.28
Super Products LLC57
Surco Products.....55
Sweet Septic Systems Inc. ..96

T

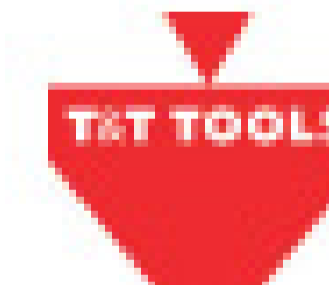

T&T Tools Inc.84
Tank Truck Service & Sales115



Tank Technologies & Supply Co LLC
TankTec.....47
The Service Program118



Toico Industries Inc.....31



Transport Truck Sales77

T



Transway Systems Inc.....35
TSF Company Inc.83
TST, LLC117
Tuf-Tite Inc.89

V

V.E. Enterprises Inc.73
Vac-Con Inc.....71
Vacutrux Limited84
Vacuum Truck Rentals51



VAR Co.43

W

Walex Products Co.41
Wallenstein Pumps-Elmira ..68
Water Cannon Inc.23
Wee Engineer Inc.72



Wells Cargo COG92
Western Sales LLC74
Westmoor Ltd.66
Wilcox Truck Sales40

Classifieds100
Marketplace106
Truck Stop110

Midwest Supplement

(after page 98)

Advance Pump & Equip.3
Allied Tank6
Engle Fabrication LLC7
Heritage Truck Equipment4
Marengo Fabricated Steel5
Mid-State Truck Service2
Milwaukee Rubber.....6
Pat's Pump & Blower4
Pierson Co.7
Rider Vacuum Sales1
T-Line Equipment Inc.2
V&H Inc.5
Vacuum Sales Inc.....4

Eastern Supplement

(after page 98)

Advance Pump & Equip.3
Allied Tank6
Andert Inc.....7
Heritage Truck Equipment4
Manchester Hose & Coupling ..2
Marengo Fabricated Steel5
Pat's Pump & Blower4
TSI Tank Services Inc.....7
V&H Inc.5
Vacuum Sales Inc.....1, 4

WORKING FOR YOU

in '09



Chandler Equipment, Inc.

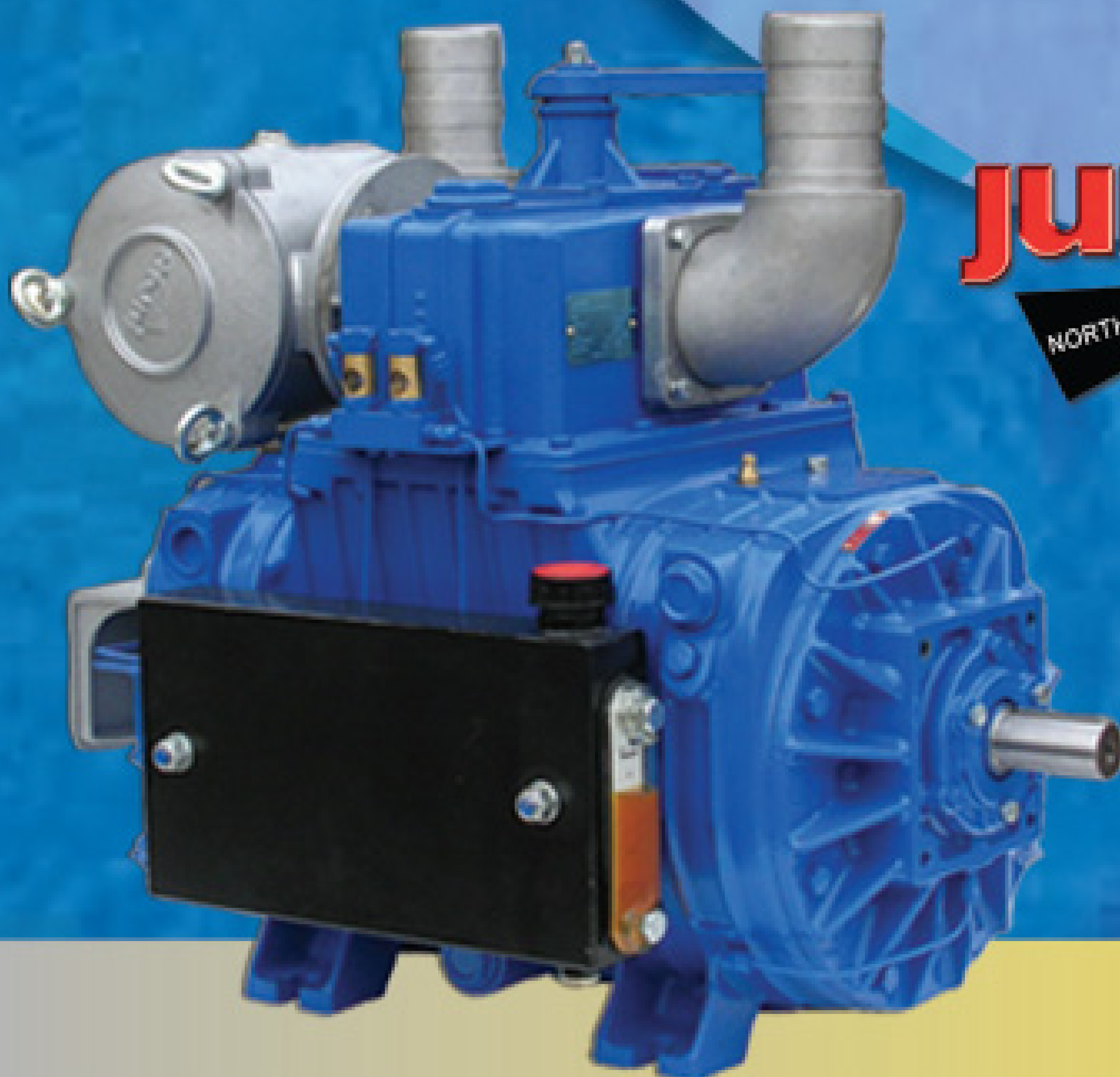

Jurop

NORTH AMERICA



800-342-0887
www.chandlerequipment.com

chempace[®]

corporation
www.chempace.com

Serving the Industry for Over 40 Years!

One-Stop-Solutions For PORTABLE SANITATION & SEPTIC & GREASE HAULERS

**BUYING DIRECT
ALWAYS EQUALS
COST SAVINGS**

Big Shot[®] Con2 & Con2 Plus

- Super Strength Concentrate
- Non-Formaldehyde
- Ideal for Summer Use

**NEW
FEATURES
ON 3 GREAT
PRODUCTS!**

**NEW
FORMULA!**

**ENHANCED
FRAGRANCE!**

**STRONGER
DYE**

Ultra PowrPak XL

Convenient Carry Pail
Effervescence

**SEPTIC TANK
ADDITIVES \$6** (Per Pkg)

**LONG
LASTING
PINK CUBE
\$160** (Per 4x5 lbs.)

*Designed to last in
hard to service
liftstations/grease traps*

**NEW
PACKAGING
OPTION**



Thanks for
visiting us!

SEWER FOAM \$59.75 (Per Pail)

*Reduce solids and hydrogen sulfide odors -
Economical approach to sewer maintenance.*

**BUY DIRECT CALL CHEMPACE
1-800-423-5350**

Letter to the Editor

He's Busting His Buttons With Pride

To the Editor:

I was surfing the 'Net today and ran across your magazine. Having subscribed to your magazine almost 30 years ago, I was interested in seeing how far you have come in the last 30 years. I started browsing and ran across an article on page 68 (January issue) about the sewer company that I started (B & B Sewer, Cheyenne, Wyo.).

Needless to say, the buttons on my shirt popped with pride as it was about my son (Bob Storms) and how he has carried on the business. Bob is one terrific young man and every man should have a son like him. I would like to think that he learned everything from me, but when I had to retire for medical reasons in 1997, I gave him the business lock, stock and barrel and he took it and ran. Under his hard work and guidance, it grew like he said.

Your story was great and your publication is also great and has come a long way, just like B & B Sewer. Keep up the good work and thank you for making an old man bust his buttons with pride.

Bill Storms
Tucson, Ariz.

Agitation SAVES Aggravation!

**CHOICE OF
2, 4' & 6'
EXTENSIONS**

**Guaranteed
To Mix Up
Septic Tanks &
Grease Traps!**

High speed rotation

busts the crust and removes solids
right off the bottom of the tank into a
total liquid form

Field tested and proven to mix a
residential tank in 5 minutes or less - takes
approx. 15minutes to agitate a 5000-10,000
gallon grease trap

**CHECK OUT OUR NEW
INFORMATIONAL DVD
PUMPER.COM/VIDEO.PHP**



Thanks for
visiting us!

Schmitz Brothers L.L.C.
PHONE 763.878.2296
FAX 763.878.2299

1.888.878.2296

**CRUST[™]
BUSTERS**

E-MAIL pete@crustbusters.com
WEB SITE www.crustbusters.com



ASK ABOUT OUR "BUSTER BRACKETS" FOR TRUCK MOUNTING

Don't be amazed
Our horizons are only a little bit wider



Floating stainless steel balls
Strong, durable, accurate

- Available in AISI 304 and AISI 316
- Excellent spherical model
- Polished TIG welding

NEW

- DN 100
- DN 150
- DN 200

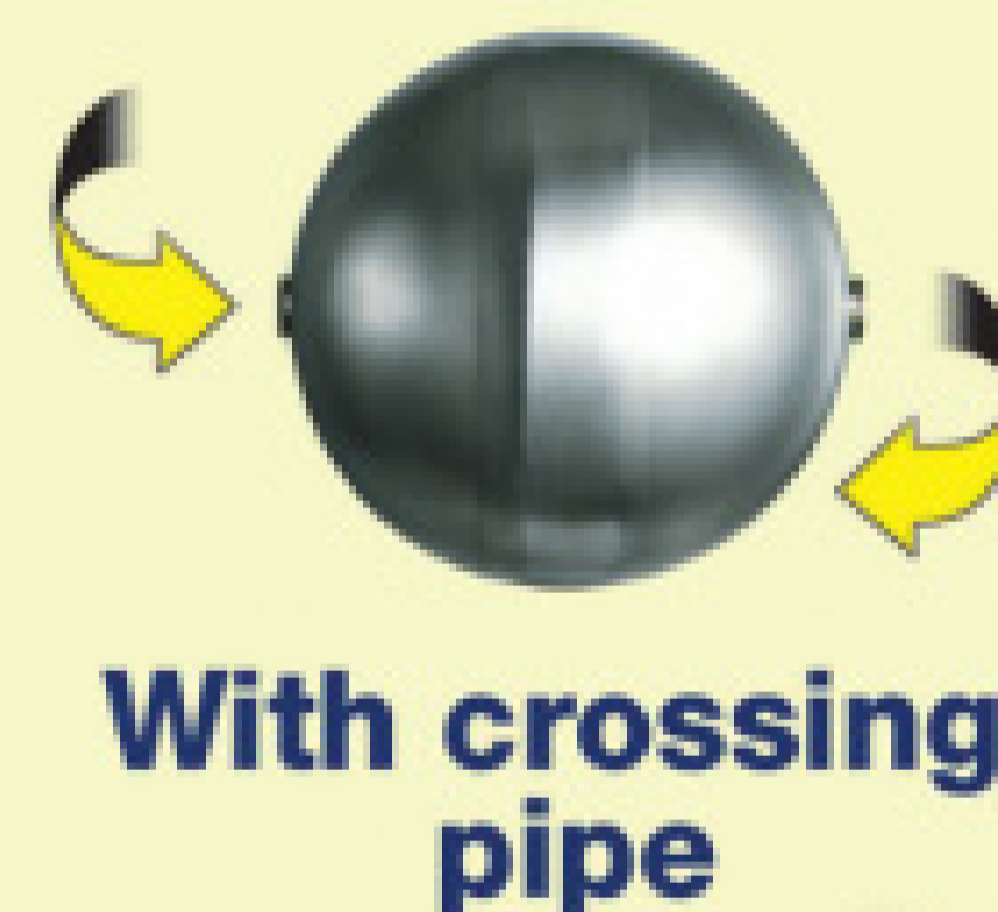

METALTECNICA s.r.l.

www.metaltecnicazanolo.com



**Chandler
Equipment, Inc.**

Toll Free 1-800-342-0887
www.chandlerequipment.com

USA DISTRIBUTORS

LELY

Commercial Wastehandling Equipment

Put Our Experience to Work for You

Aluminum Tanks • Full Open Door Hoist Tanks

ASME DOT 407/412 Code Tanks

- Standard and custom tanks
- Carbon steel and aluminum available
- A tradition of reliable service
- Large range of sizes (400 - 6000 Gal.)
- Complete line of parts



- 1) Vacuum and Pressure Relief Valves
- 2) Easy to Read Vacuum and Pressure Gauges
- 3) Balanced Tubular Pump Drive Shafts
- 4) Full Length Hose Trays
- 5) Get Tank Protection with Aluminum or Spray Liner
- 6) Low Profile Primary Shut-Off with SS Float Ball
- 7) 20" Top Manway
- 8) Three 5" Sight Glasses
- 9) Stainless Steel Boxed Upper ID Light Bracket with Truck-Lite Brand Lights
- 10) 24" Rear Manway with 4" or 6" Discharge with Camlock Fittings (up to 36")
- 11) DOT Approved Step Bumpers
- 12) 4 Anti-Sail Mud Flaps
- 13) Large Hose Hooks
- 14) 3" or 4" Intake
- 15) We carry blower packages for your heavy duty jobs

Portable Toilet Trucks

Available On All Models

- Hot Shift PTO with Automatic Transmission
- Balanced PTO Axle
- Heavy Duty Toilet Carrier
- Trailer Hitch
- Spring Rewind Reel (Optional Dual Service)
- 2" Bucket Quick Fill
- Driver Side Work Station
- Dual Side Tool Box



- Electric Water Pump 40 PSI 6 GPM (Air Pressurized Optional)
- Coated Water Compartment
- Full Set of Working Lights
- Truck-Lite Lights
- 50 ft. Water Hose with Nozzle
- Vacuum and Pressure Relief Valve

5.5% FINANCING AVAILABLE.

Lely Manufacturing, Inc.

P.O. Box 789 Wilson, NC 27393

800.334.2763

sales@lelyus.com



—partners in wastehandling—

www.lelyus.com

ALPHA Mobile Solutions

Restroom & Shower Trailers

\$90 DOWN
\$90 per MONTH
for 90 DAYS*



Thank you
for
visiting us
in
Louisville

www.alphamobilesolutions.com (877) 789-1213

*With Qualified Credit/Ask About Details

Specializing In Truck Flotation Tires & Wheels



Over 1000 tires & wheels in stock

ALLIANCE

The Leader in Truck Flotation Tires!



TRELLEBORG

TIRE SPECIFICATIONS

Item	Dimension	Load
400/55x22.6 Alliance - 328 MPF	16" w x 41" h	7,500 lbs at 40 mph
500/45x22.5 Alliance - 328 MPF	20" w x 41" h	8,500 lbs at 40 mph
550/45x22.5 Alliance - 328 MPF	22" w x 42" h	9,000 lbs at 45 mph
600/40x22.5 Alliance - 331-380	24" w x 42" h	8,800 lbs at 30 mph
600/50x22.5 Alliance - 331-328	24" w x 46" h	10,000 lbs at 30 mph
700/40x22.5 Alliance - 331-328	28" w x 46" h	11,000 lbs at 30 mph
750/45x22.5 Alliance - Radial-380	30" w x 49" h	12,730 lbs at 40 mph
700/40x26.5 Alliance - 331	28" w x 50" h	10,000 lbs at 30 mph
800/45Rx26.5 Alliance - 331	32" w x 55" h	16,000 lbs at 40 mph
28Lx26 Alliance - Blae & Radial	28" w x 60" h	13,000 lbs at 30 mph
620/50x22.5 Trelleborg	25" w x 45" h	9,900 lbs at 40 mph
710/40x22.5 Trelleborg	29" w x 45" h	10,450 lbs at 40 mph

328MPF



High Flotation

380 Radial



High Speed Traction

331 18 Ply



Super Traction

390 Radial



High Speed Trailer

Diller Equipment

Somerset, PA

Great Freight Rates

(800) 640-4448

Ask For Lynn

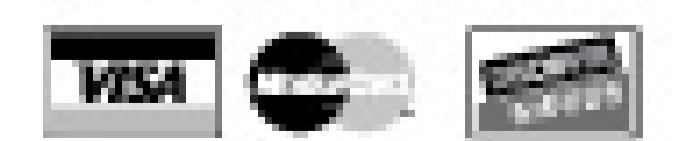

NO COMPROMISE



Masport
HXL400WV



FRUITLAND
RCF500F



GD Wittig
RFL100



GD Sutorbilt
4M

At Armstrong Equipment, we believe life and business require certain compromises, but not on those things on which your business and family depend. A beautiful, new and shiny vacuum truck with a burned out pump is nothing more than uncomfortable transportation at four miles per gallon.

Your customers depend on you! Your employees depend on you! Your family depends on you!

We think you should be able to depend on **us!** That is why we sell the most dependable vacuum pumps, parts, valves and tank components available. When it comes to quality and reliability in the tools that make your business successful, there should be:

“No Compromise.”

We proudly stock Masport, Fruitland and G-D Wittig vacuum pumps, Sutorbilt blowers, Garnet Instruments SeeLevel gauges, Clearflow Heavy Duty valves and most other vacuum truck components and accessories. We can also provide replacement pumps and repair kits for most major brands. For more information call us toll free at **800-699-7557.**

**ARMSTRONG
EQUIPMENT
INC.**

800-699-7557

11200 Greenstone Ave. • Santa Fe Springs, CA 90670

562-944-0404 • Fax: 562-944-3636

www.vacpump.com

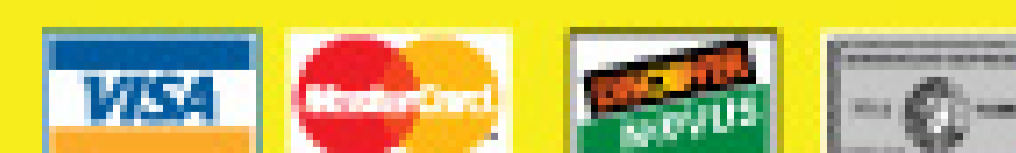



DRAGON PRODUCTS, LTD.

MADE IN THE USA!

500bbl Liquid Storage Tanks

FOLDING HAND

WITH 1/4" STEEL P



Single Container Trailers
Liquid Tight Vacuum Containers

Roll-Off Hoist

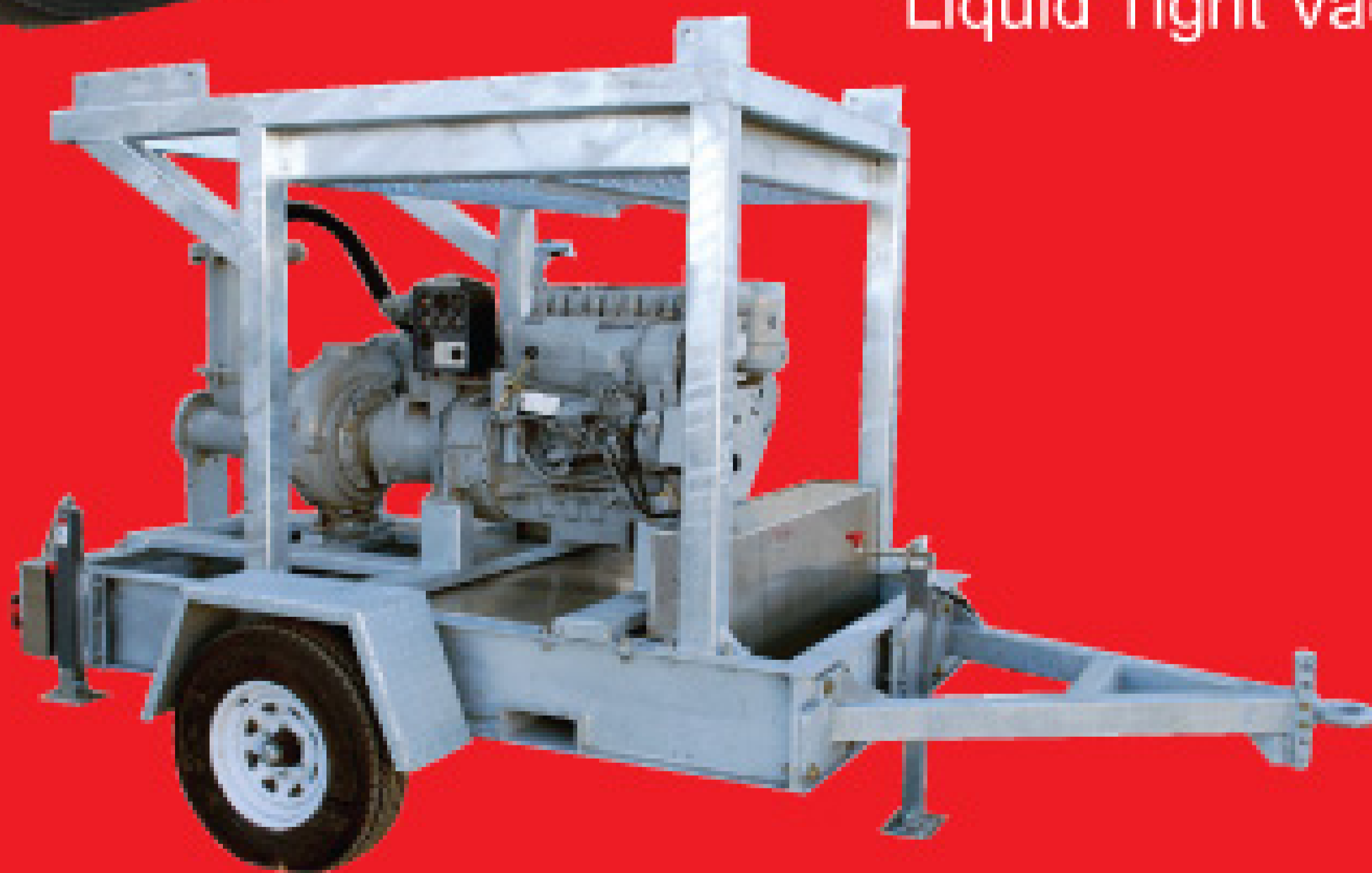

Self Priming Mobile Pump System



Two Container Trailers
Open Top Dewatering Containers

email for more information:
sales@modernusa.com

877-778-4280

A Modern Group Company

check out our website:
www.modernusa.com



DRAGON

PRODUCTS, LTD.

MADE IN THE USA!



Insulated Stainless Steel Tankers

72 WALL



Aluminum/Stainless Steel Bobtails



Aluminum Double Conicals



Full Rear End Open Steel Bobtails



Aluminum/Carbon Steel/Stainless Steel Vacuum Tankers

email for more information:
sales@modernusa.com

877-778-4280

A Modern Group Company

check out our website:
www.modernusa.com



In response to our valued partners ever increasing needs. **JAG Mobile Solutions** has increased our product offerings. We're proud to be your **Industry Leader** for ADA Solutions, Towability Solutions, Solar Solutions and Shower & Mobile Restroom Solutions. Bring us your need, we'll provide your **Solution**. Isn't it time to expect more from your mobile restroom manufacturer?

Make a decision you can live with.

JAG Mobile Solutions



Call **800.815.2557**



www.jagmobilesolutions.com

We've Got You Covered

Whatever you need in ground protection mats

With the acquisition of Mobile Mats, AltumaMATS now is able to offer the broadest line of ground protection mats in the industry...literally, we've got you covered. Now Mobile Mats will be available through AltumaMATS' and MobileMats' extensive dealer networks. All three mats leave soft turf smooth, even under heavy vehicle traffic and all are guaranteed for 6 years. No costly turf repair bills and NEVER GET STUCK AGAIN.

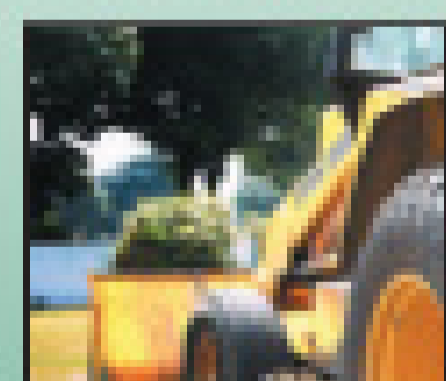

Landscaping

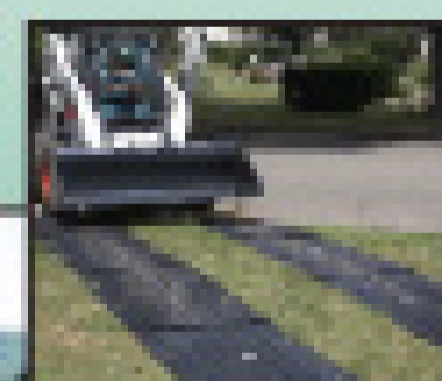

Genetry

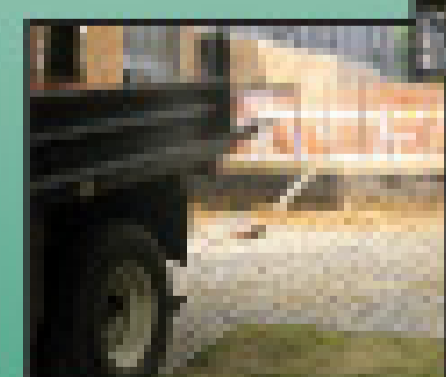

Construction



Drivng

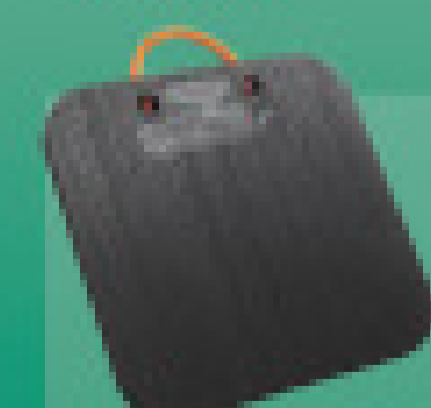

One-Piece Plastic Outrigger Pads
Various sizes available!



See us at the
NTEA Show
March 4-6, 2009
BOOTH #2387

AltumaMATS continues as the world's largest producer of quality ground protection mats.

AltumaMATS

sales@altumamats.com

Call for the name of your nearby dealer: **888-544-6287** www.altumamats.com

Septic-Scrub™

The Demonstrated Drainfield Restoration/Maintenance Solution

Backed By Science ■ Proven with Experience ■ Many Satisfied Homeowners

Septic-Scrub™ is a superior product for the maintenance and restoration of septic system drainfields. Customers appreciate that it is environmentally safe, contains no organic chemicals and does not produce any toxic by-products. Most importantly, **Septic-Scrub works**. It breaks down sulfide buildup in the biomat and soil to allow for better water absorption.

Learn more about Septic-Scrub at www.arcan.com.

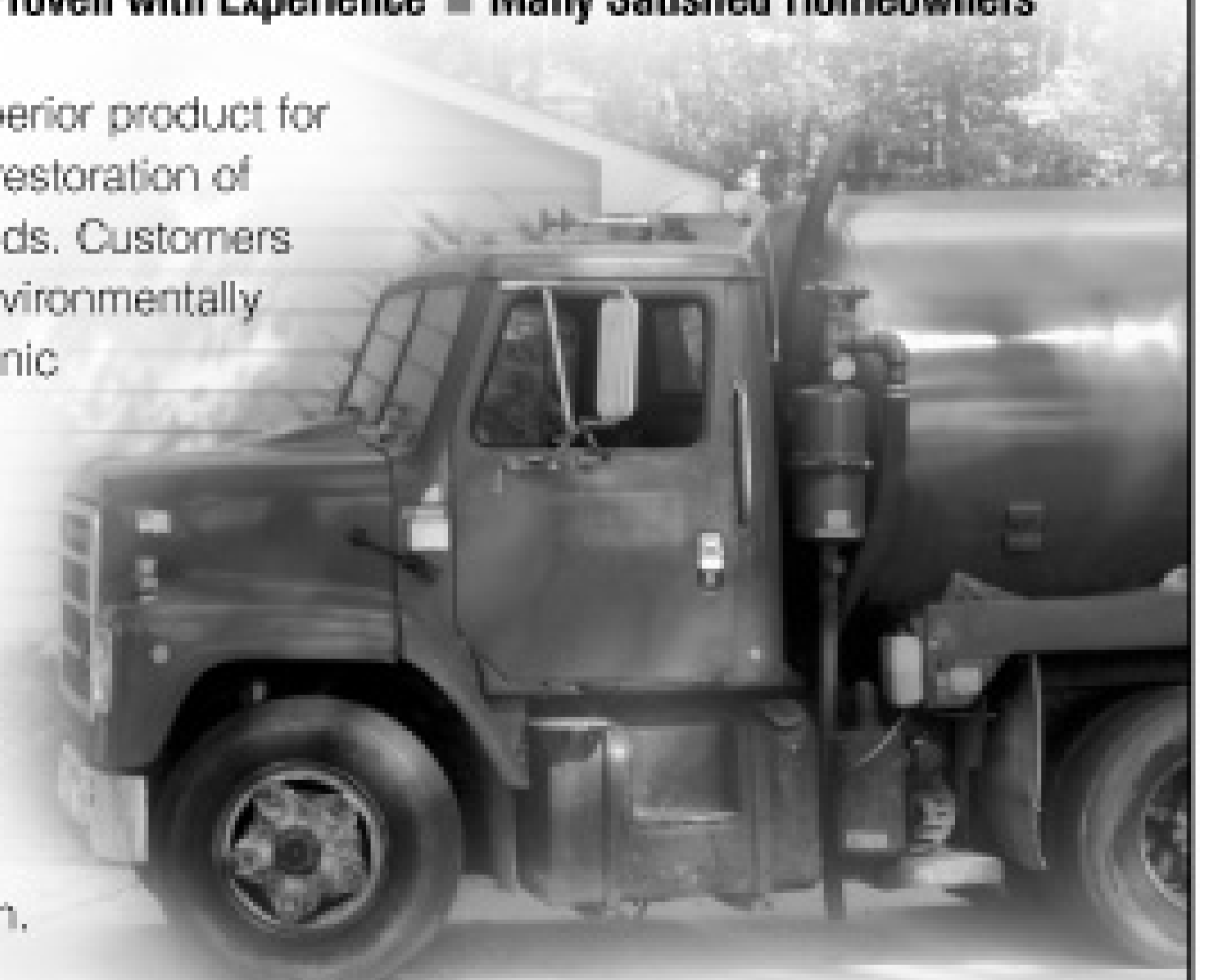

arcan

P.O. Box 65
Scotch Plains, NJ 07076-0065

For information on increasing sales and providing a valuable service to your customers, call Arcan Enterprises at **888-35ARCAN (352-7226)**

1-YEAR, 100,000 MILE ENGINE WARRANTY NATIONWIDE • COMPARE OUR TRUCKS AND PRICES TO ANYONE



2002 MACK VISION
4000 Gal US Tanks, New Jurop LC 420 Water Cooled,
Ready For Immediate Delivery



2005 MACK VISION
4000 Gal US Tanks, Camel Back Rears, Double Frame,
Ready For Immediate Delivery



2-2003 INTERNATIONAL 9200
4800 Gal US Tanks, Double Frame, Tag Axle, Jurop LC 420,
Ready For Immediate Delivery



2005 MACK VISION
4000 Gal US Tanks, Jurop LC 420 Water Cooled, Double Frame,
Ready For Immediate Delivery



2005 MACK VISION
3600 Gal US Tanks, Double Frame, Jurop 420 CFM, Water Cooled,
Ready For Immediate Delivery



Thank you for visiting
us in Louisville.

OUR 28TH YEAR
NATIONAL TRUCK CENTER

9750 N.W. 27th Ave. | Miami, FL 33147 | Phone: 305.691.8407 | Fax: 305.691.8416

www.nationaltruckcenter.com

★ WE EXPORT OR DELIVER ★

Please Call For More Info
ISRAEL VERA: 305-525-6406
GEORGE GONZALEZ: 954-558-0816

U.S.
Tanks

THE TOP DOG OF VACUUM TANKS

Create a Reminder Card System

A simple-to-organize postcard mailing generates sales and stabilizes both workflow and cash flow

Robert Barnes is the owner of King's Pumping Service, Dallas, Ore. Reach him by e-mail at rbrbrb6@hotmail.com or by phone at 503/831-0104.



By Robb Barnes

Retaining a customer is more cost-effective than securing a new one, so once you have educated a customer on the various aspects of his septic system and explained the benefits of preventive maintenance, the next job is customer retention. Utilizing a reminder card system is an effective way to do this.

BENEFITS ARE MANY

The most obvious benefit of a reminder system to your company is increased sales. Many uneducated customers have their septic tanks serviced on an "as needed" basis. This means the customer only calls when a problem has occurred. By placing customers in a reminder card system, you are initiating the service call on a regularly scheduled basis, rather than a crisis basis. In other words, you are proactive in generating sales rather than reacting to emergency calls.

Second, after a short time you will start generating a substantial reminder list for every month of the year. This results in more consistent workflow and more consistent cash flow. Rather than feast in the summer months and famine in the winter, the reminder card system will enable you to keep your equipment and employees working year-round as weather allows.

Third, a reminder card system can dramatically reduce the number of after hours and weekend emergency calls you receive. Also, it reduces your operating costs because a maintained system is easier and faster to service and requires less labor and equipment costs to pump than a tank that only gets pumped once every 12-15 years.

Along with this reduction in operating costs is an increase in scheduling efficiency due to more accurate service time estimation for each job. In other words, you know you can schedule jobs every two hours if they are for scheduled maintenance rather than an emergency.

MAKING THE MOST OF ACCOUNTING SOFTWARE

There are a variety of good computer programs you can use to develop reminder scheduling and many of us already have one bundled in our accounting software. We utilize one of the most common systems, QuickBooks from Intuit.

QuickBooks offers several features that adapt to a pumping business. All of these features are found in the Customer Center part of the program. The first feature is the *Additional Info* tab on the customer page. The left side of this window features fields such as *Type*, e.g. resi-

When that system is ready to be serviced again, it only takes a minute to ... print it for the service technician. This allows them to not only find the jobsite faster, but gives the advantage of having a history of the system before they arrive at the site.

dential, commercial, school, etc., *Terms, Rep* and *Preferred Send Method*.

The right side of the window features a number of fields that are customer adaptable. For our company, we have changed these fields to include such things as tank size, tank type, tank condition, amount of hose needed, reminder frequency, next reminder date and previous pump date. By listing this data, we can see at a glance most of the critical information about that system. This also aids in scheduling because it lets us see if a job requires more time due to depth of the tank lid, if it is a long pull and needs more time to pull more hose and even such things as if the jobsite is level or if there is an elevation difference between the tank location and where the truck can park. These are critical factors in determining estimated service times.

The next feature is found on the same page in the small menu found

in the upper right hand corner of the Customer Account page. One of the items in this menu is a box labeled *Notes*. Once an account is set up and the data listed as far as billing info, tank size etc., if you click on the *Notes* box, it will bring up a notepad window with the account information, customer contact and telephone number listed at the top. Below this information is a notepad area where you can insert pertinent information about the job.

CREATE A WORK HISTORY

We start with a description of directions to the jobsite, depth of tank, where the access port is located, type of baffles, etc. We also include information about access, if the driveway is steep and gravel, need to go with a partial load for traction, any gate combinations, low hanging overhead lines and whether there is room to turn around or if we need to back in from the road. We also include measurements to the lid location from individual reference points and we list the work order number that the map is drawn on.

Once this background information is in place, it is a simple matter

ESTIMATED SEPTIC TANK PUMPING FREQUENCIES (IN YEARS)*									
Tank Size (Gal.)	HOUSEHOLD SIZE (NUMBER OF PEOPLE)								
	1	2	3	4	5	6	7	8	9
500	5.8	2.6	1.5	1.0	0.7	0.4	0.3	0.2	0.1
750	9.1	4.2	2.6	1.8	1.3	1.0	0.7	0.6	0.4
1000	12.4	5.9	3.7	2.6	2.0	1.5	1.2	1.0	0.8
1250	15.6	7.5	4.8	3.4	2.6	2.0	1.7	1.4	1.2
1500	18.9	9.1	5.9	4.2	3.3	2.6	2.1	1.8	1.5

Note: More frequent pumping is needed if garbage disposal is used.

* Data provided by Oregon State University Extension Service

of opening this *Notes* window each time a service call is made, placing the cursor below the last line of the narrative and hitting the *Date Stamp* box on the right side of the window. The system automatically enters that day's date and it is easy to list the work order number, the service provided, the cost of each item and any other pertinent information from the day's service call.

This allows you to build a history record of all the work done on each system. When that system is ready to be serviced again, it only takes a minute to pull up the *Notes* window and print it for the service technician. This allows them to not only find the jobsite faster, but gives the advantage of having a history of the system before they arrive at the site.

Having detailed records is especially important if your company has several service technicians or if you experience technician turnover. It also becomes an important asset to your business if and when you decide to sell. Imagine the benefit and value to a potential buyer when you can show that each job has a full history and each customer is part of a working reminder system.

One side note about setting up your pumping customer accounts in any bookkeeping system: Consider creating your customer list using the address where the tank is located, not necessarily by the property owner's name. Most homes change ownership every six to seven years. What doesn't change is the location of the tank, the address of the home and the size of the tank. This makes it very easy to look up a location when a new owner calls and asks about a system, and it is easy to change the billing party's name if the property is sold.

SCHEDULING THE REMINDER CARDS

Once the notes are entered, it is time to look at the *New to Do* box in the upper right corner, just below the *Date Stamp* box. By clicking on the *New to Do* box, a new window appears with a small notepad area and a box labeled *Remind Me On*. This is the heart of the reminder system. In the notepad area, you input as much information needed to generate your reminder list. For our company this includes address, size of tank, pumping frequency, name of resident and date of last pump. Once this information is logged, go to the *Remind Me On* box and put in the date the next reminder is due to be sent, then click the *OK* box and your reminder is now in your QuickBooks system.

Once the reminders are in your system, it is a simple matter to print a list of reminders that are due to be sent out for the month. Filter the report for any reminders dated from the first to the last day of the month, hit print, and you have a list of customers who get reminder cards for that month.

INCLUDE VALUABLE INFORMATION

Our reminder cards feature a color photo of our truck on the front and the back has a small version of the frequency chart and a place for us to list the customer's tank size, date it was last pumped and suggested pumping frequency. This lets them verify for themselves that the system is due for service.

While the reminder system may sound complicated, it is amazingly easy to use and maintain. When you combine the benefits of educating your customers, helping them to avoid expensive repair costs, becoming the "go-to guy" for all their septic needs and reminding them when their system needs servicing, you will find that you and your business will reap many rewards. ■

Built Better to Perform Better™



Compact, heavy duty vibration-resistant hose reels

Photo courtesy of Vetroc, a subsidiary of Federal Signal Corporation



Highest rigidity, ultra heavy duty cast aluminum Series 8000

Best in their Class Signature Reels

NEW!

Dual pedestal reel ideal for washdown, sanitizing

Patent Pending Series DP7000

800-444-3134

reelcraft.com/pumpercleaner

Made in USA

REELCRAFT

Wind Things Up With Reelcraft™

YOUR PROBLEM IS



Jim Pierce, Southeastern Division Manager

JUST ASK. IS THERE SOMETHING WE CAN DO FOR YOU?

We've always felt that our customer's problems were our problems, too. It was one of our founding principles. The people in the industry we serve, their integrity, and their zeal to provide good service mean a lot to us. That's why we've worked hand-in-hand with our customers for nearly 40 years; listening and helping them solve their problems.

So even though your restroom business may be going through some rough times right now, when things get better we believe that quality, integrity and service will have prevailed – in your business and in ours. Thanks for your loyalty and trust.



OUR PROBLEM, TOO

ONE TRUCK SHORT OF GOOD SERVICE

July 2005. Hurricane Dennis had just struck the Florida panhandle, and one of Jim's customers was moving his operation to the Pensacola area to set up for the Forest Service and FEMA. The customer's entire crew was on the panhandle, yet he was short one pump truck. The truck was in Atlanta.

Jim packed a bag, and took off with the truck toward the disaster area. He got as far as Montgomery, Alabama the first night. Due to the crush of evacuees, there were no hotels available so he slept in the truck cab. He arrived at the staging area the next day, and then spent a couple more nights in the truck, coordinating deliveries for his customer, and generally helping out any way he could.



VISIT WWW.POLYPORTABLES.COM TO SEE OUR COMPLETE LINE OF PRODUCTS AND SERVICES



POLY-STANDARD

The Poly-Standard has been the backbone of the PolyPortables line for almost 40 years. It's been tried and proven under every conceivable condition and it's still one of the best restroom values on the market. Many successful businesses have been built around the Poly-Standard unit.

VANTAGE

Looking for the best? The Vantage is a double-walled unit that is built like a fort, with smooth interior walls for easy cleaning. A wide doorway offers convenient entry and there are features that make the Vantage a real workhorse and a pleasure to handle. Check it out online at www.Polyportables.com

INTEGRA

The Integra features a high Keystone roof and wide entrance doorway. It has become our most popular restroom. Many structural parts are interchangeable between the Poly-Standard and Integra models thereby reducing parts inventories and enabling operators to keep their inventory active.

Visit www.Polyportables.com to see our complete line of:

- Portable toilets
- Special needs and VIP units
- Hand Wash stations
- Pumper and flatbed trucks
- Cleaners and deodorizers from Green Way Products
- Business and marketing tips

TOILET DEODORIZERS • TOILET CLEANERS • AIR FRESHENERS • INSECT REPELLANT

All Green Way deodorizers, cleaners and air fresheners are earth-friendly, people-friendly products. They are developed and manufactured in our facilities in Dahlonega, Georgia by Green Way Products, a PolyPortables sister company.



Dewatering Containers



Thanks for visiting us!

Bakers Waste Equipment Inc (BWE) designs and manufactures dewatering sludge containers which are specified to provide septic and grease haulers onsite waste processing capabilities.

Filter Panel Structures are available in stainless steel, galvanized, or mild steel with chemical resistant protective coatings on the substructure.

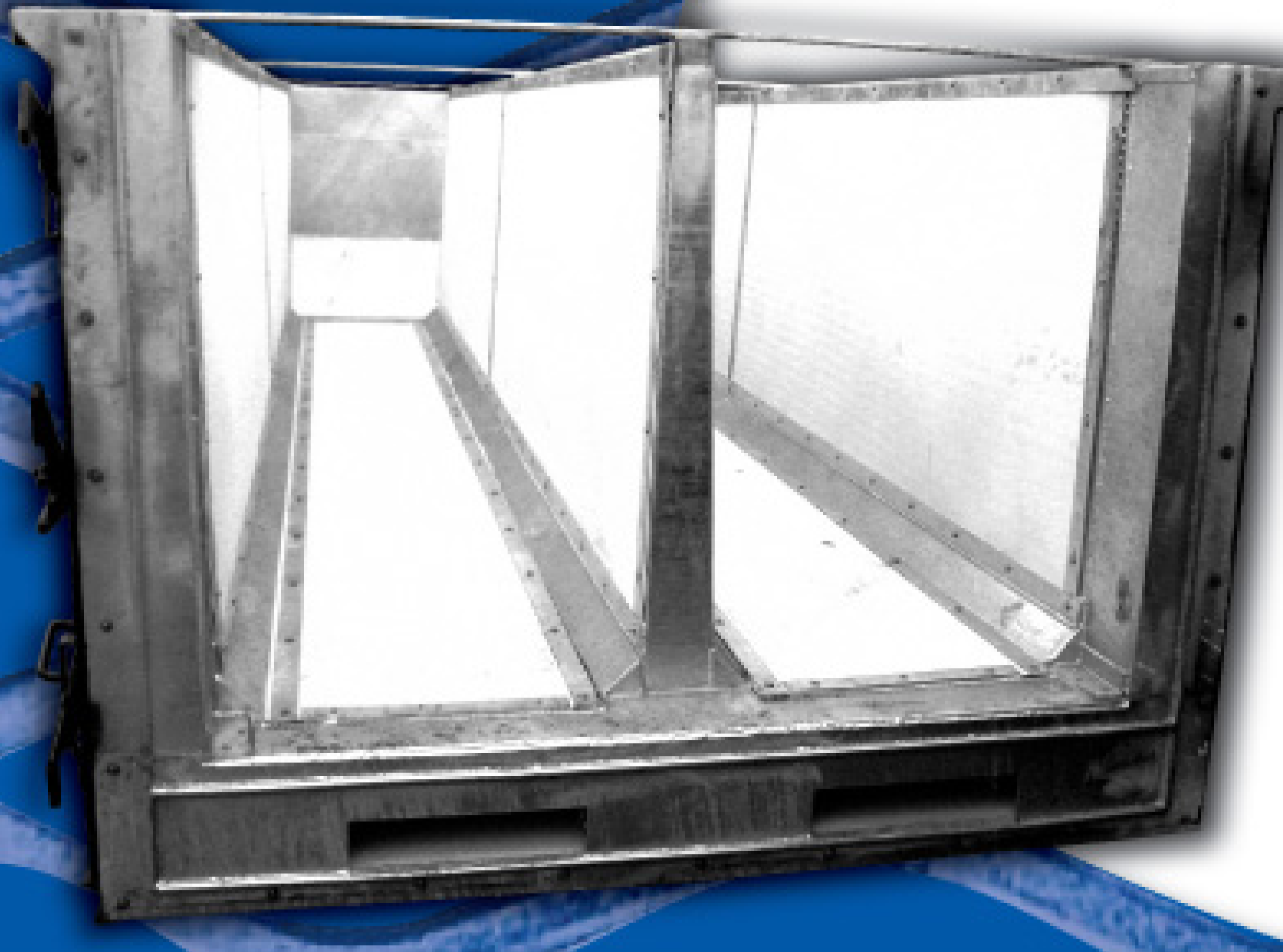

Standard Specifications Include:

Capacities in 15, 20, 30, and 40 cubic yard designs
 Heavy Duty Construction
 Processing Rates from 15,000 to 25,000 Gallons Per Day
 Internal Center Wall Provides Dual Compartments for More Efficient Filtration and Separation of Waste.

Designs Available with Permanent (330 Micron) or Disposable Filter Media
 (3) Ratchet Closures on Sealed Sludge Gate
 Cable Lift or Hook Lift Capabilities



BAKERS WASTE EQUIPMENT

800/221-4153
828/879-8222
828/879-8557 fax
www.bwe-nc.com

Daily • Weekly • Monthly Rentals • Rent-to-Own
 Our goal is to ensure that every pre-owned or rental unit we offer provides the most value for your money.



STANDARD
Rebuilt & Rental
 800-633-2997
 www.standardequipment.com

A&L Systems

25415 Glendale
 Redford, MI 48239
 Phone: 313.533.7100 or
800.592.5253
 www.a-and-lsystems.com

Heavy-Duty Lighting & Accessories



Automatic On/Off Motion Sensor

Now With Theft Deterrent Mounting Brackets
 3 LED's for Greater Illumination



The battery operated LED Light automatically turns itself on when motion is detected by the built in sensor and turns itself off 30 seconds after you leave the area. Dusk to dawn sensor prevents daylight activation.



- White LED Lights
- Stop/Tail/Turn Lights
- LED Lighting
- LED Clearance Marker Lights
- LED Front Air Cleaner Lights
- Halogen Driving Light Systems
- Strobes • Revolving Lights • Flashing Lights
- Visor Lights • Remote Power Supply
- Traffic Safety • Bar Lighting • Alarms

**20HP GX 620 HONDA
3000PSI**



- *Twin Cylinder
- *Electric Start (Included)
- *Assembled Ready To Work
- *15 Point Inspected
- *We Customize

Part # 12H09
TSF Series
8GPM @ 3000PSI
\$2,799

Part # 12H03
XW Series
8GPM @ 3000PSI
\$2,829

**24HP GX 670 HONDA
3500PSI**



- *4 Redundant V-Belt Drive
- *Convenient Key Start
- *We Test Run Every Model
- *Lifetime Frame Warranty
- *Plumbing Options Available

Part # 12H15
TSF Series
8GPM @ 3500PSI
\$2,999

Part # 12H12
XW Series
8GPM @ 3500PSI
\$3,049

Oil Drain Kit

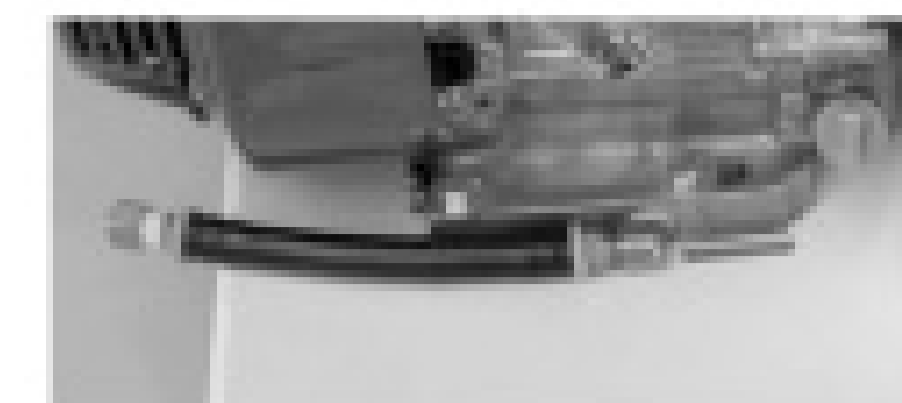

Available on
Most Models
For **\$19.99**
Installed



EZ Start Feature
Eliminate
Static Back Pressure
Part # 11234
\$29

Customized Specifications



Our Industry Veterans
Understand Your Needs

Tank Feed Options



Dozens of Options
Tell us Your Needs

Build Your Own Trailer



Fax Your Specs To
1-888-928-9274
Let Us Help You Design

Large Capacity Hose Reels

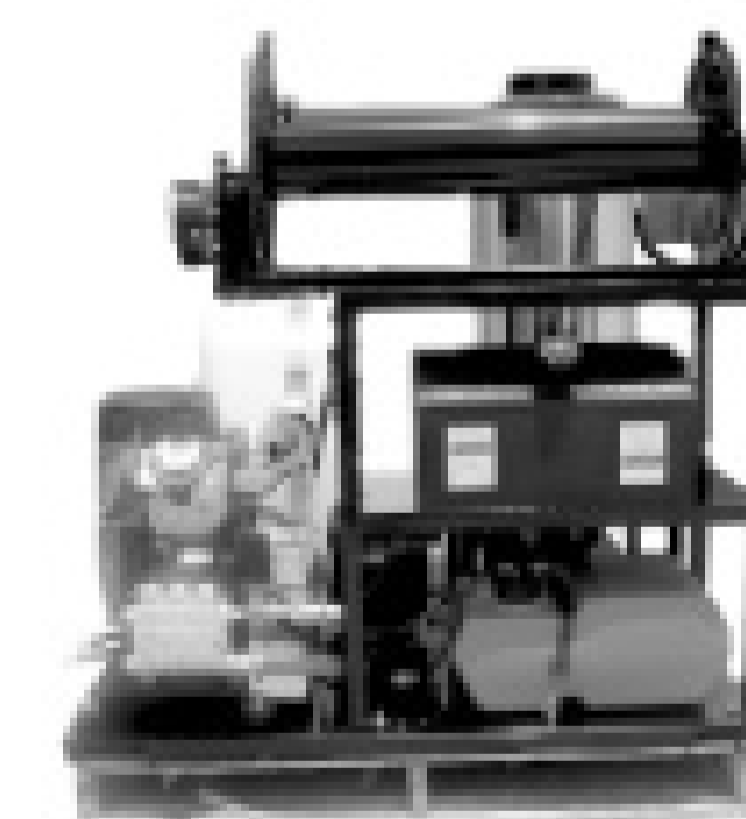

We Feature Quality
HOSETRACT
your Best Convenience Store

Extreme Duty Attachment Kits



Includes: 4 Nozzles
6000PSI
50' Kit
Part # 11569
\$269



7000PSI
50' Kit
Part # 11599
\$299



FAIRNESS PREVAILS @ WATER CANNON

We Strive To Be Fair in Everything We Do *Celebrating 28 Years*

1-800-333-9274

20HP GX 620 HONDA - 4000PSI

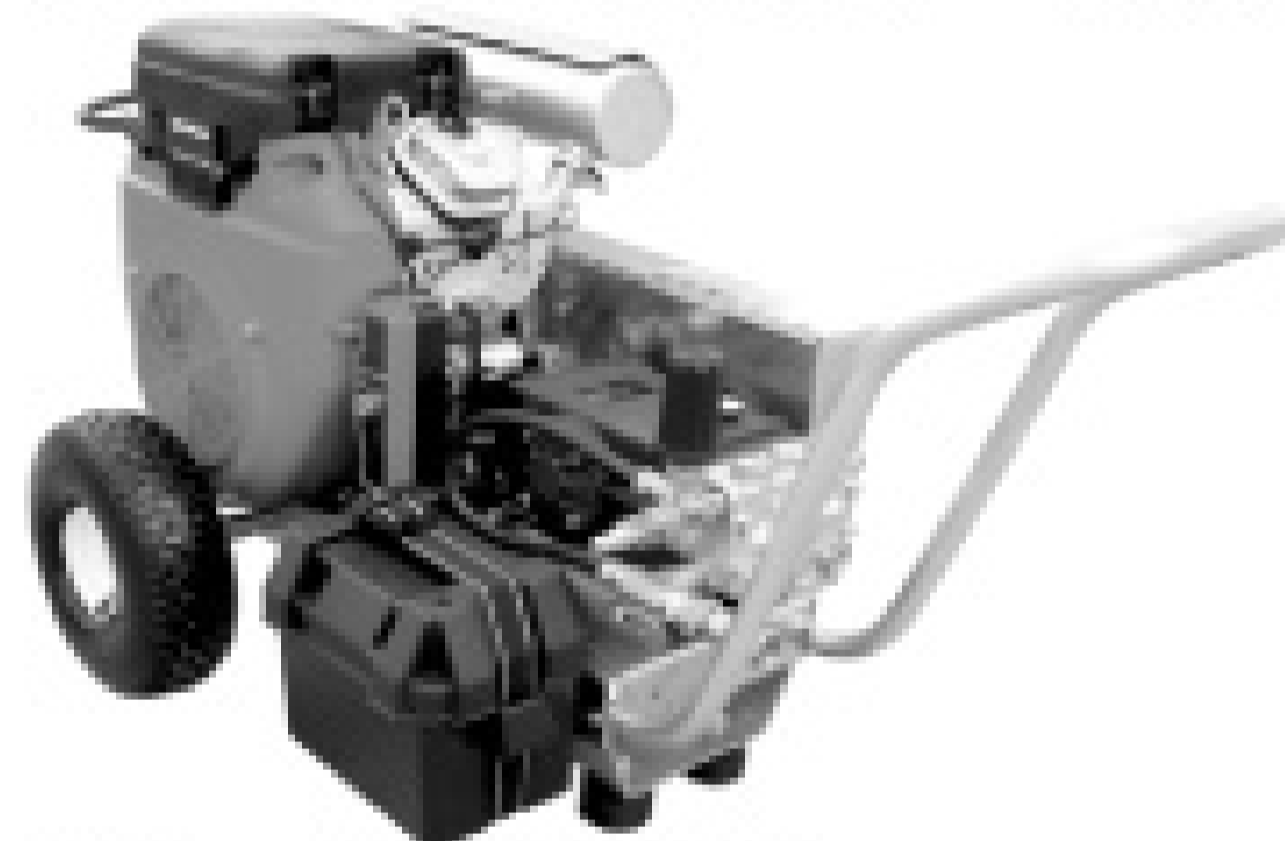

- *Laser Aligned 4 Belt Drive
- *Triplex Ceramic Plunger Pump
- *Cool Deck Lifetime Frame
- *Great for Surface Cleaning

Part # 12H21
XW Series
5.5GPM
\$2,749

Part # 12H25
TSP Series
5.5GPM
\$2,829

HONDA 5000PSI V-Belt

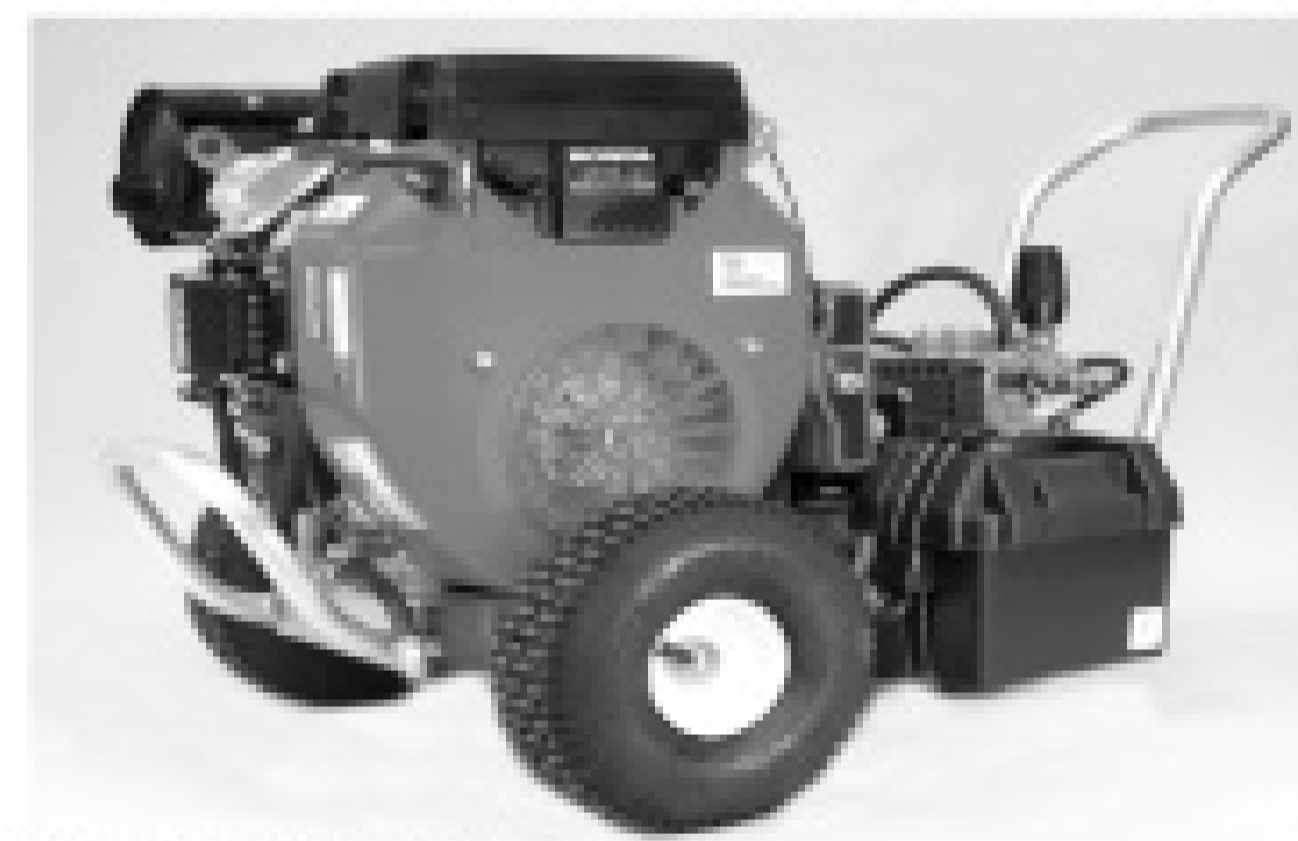

- *Adjustable Throttle
- *Remote 6 Gallon Tank
- *Unbreakable Axle
- *Thermal Overheat Protection

Part # 12H33
TSP Series
4.5GPM - 20HP
\$2,989

Part # 12H36
TSP Series
5.5GPM - 24HP
\$3,199

24HP HONDA 6000PSI



- *Increased Blasting Power
- *Industrial/Rental Duty
- *6000PSI & Above Models
Requires Purchase of Attachment Kit

Part # 12H45
TSP Series
4.5GPM
\$4,439

NEW XT SERIES

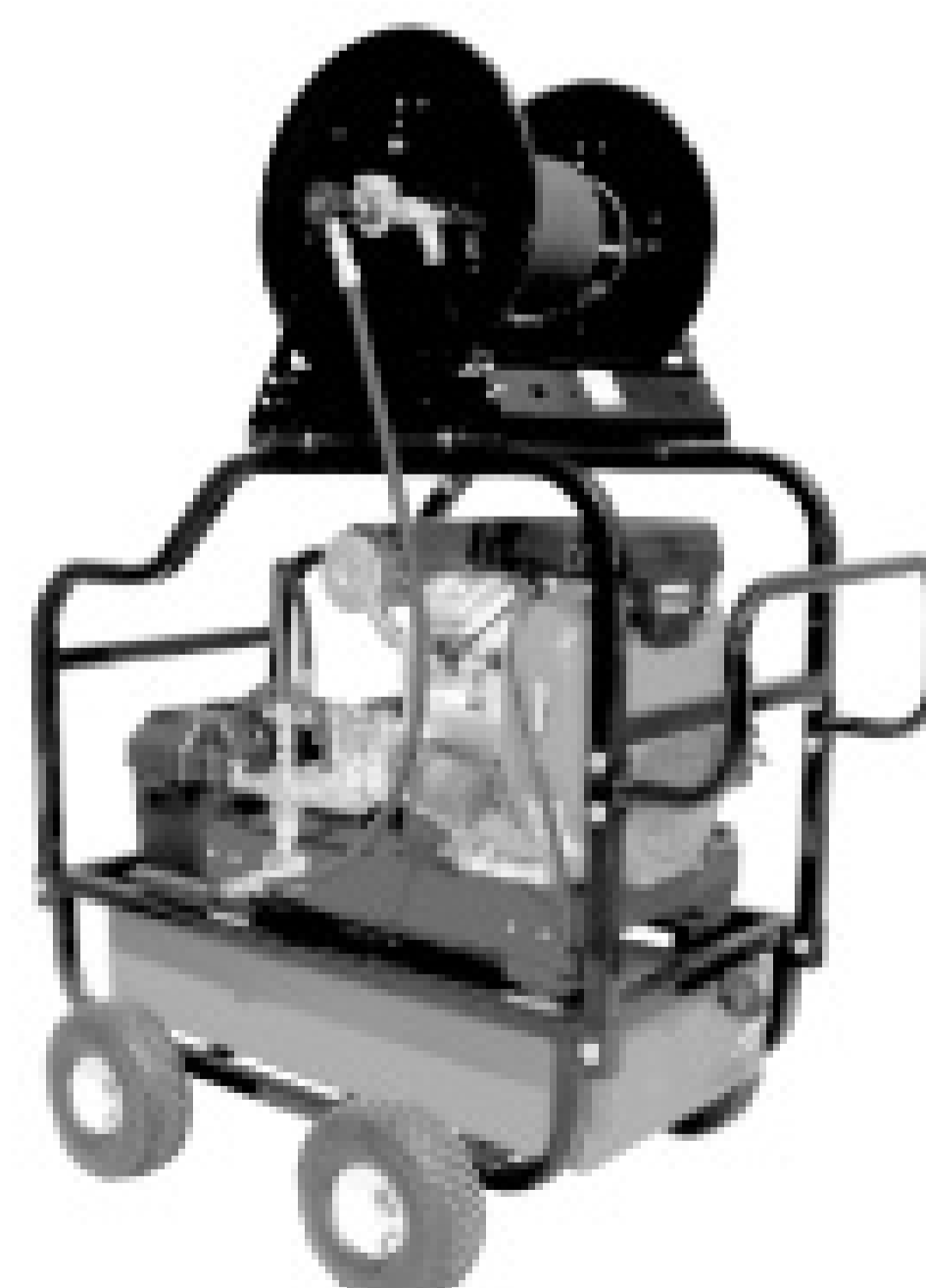

- *See Page 10
- *4 to 8 GPM
- *Up To 7000PSI
- *Up To 40HP
- *Long Run Time
- *Jetter Versions Available
- *V-Belt & Gates Poly Drive

HOSE ASSEMBLIES

MANUFACTURED TO YOUR EXACT HOSE REQUIREMENTS BY THE LEADING SOURCE IN HOSE FABRICATION.

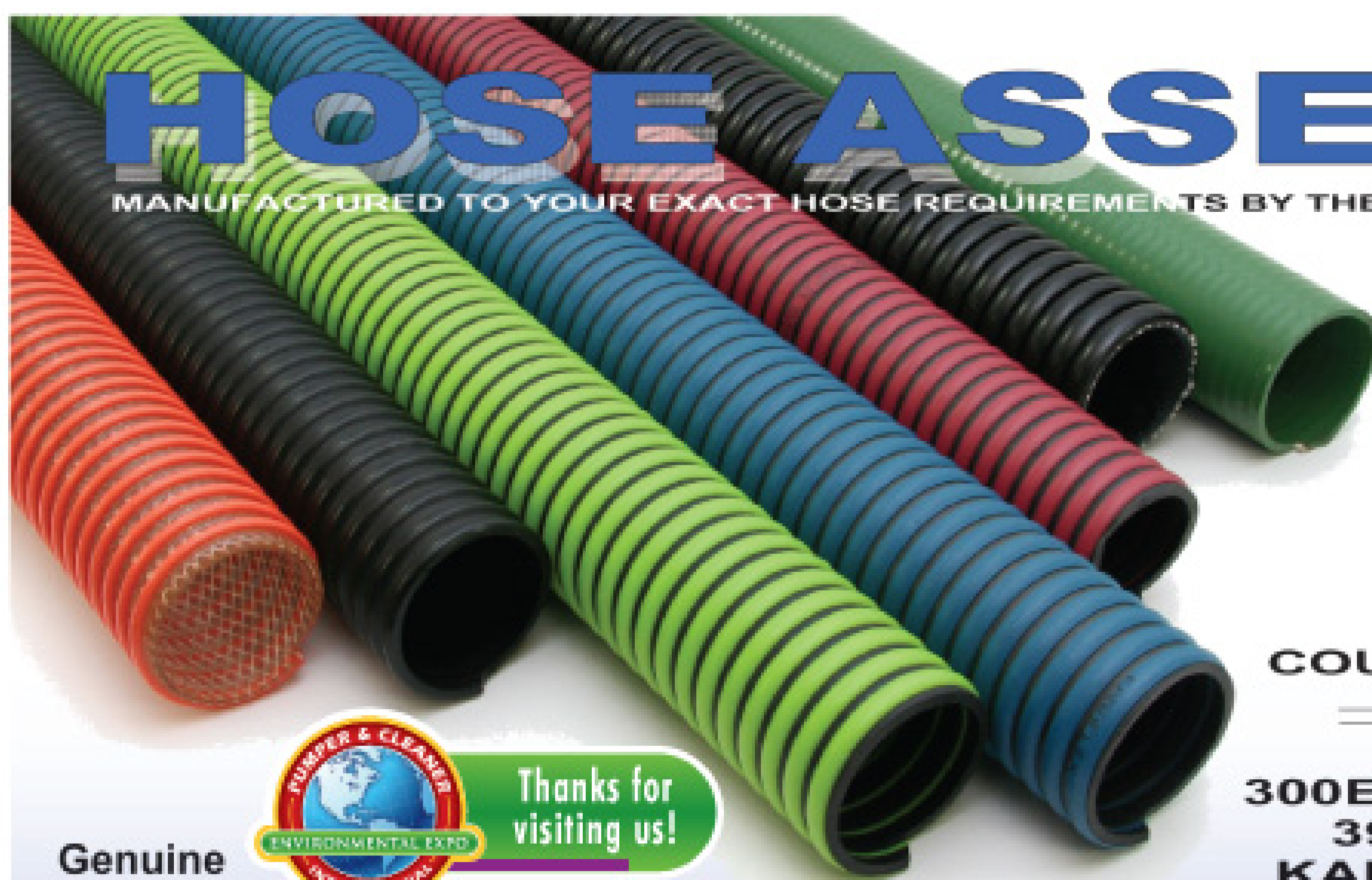

**LOWEST PRICES
GUARANTEED
ON ALL OF OUR
"QUICK-SHIP"**

ITEMS

INCLUDING
HOSE & ASSEMBLIES
COUPLINGS • VALVES • ADAPTERS

300EPDM • 180AR • 180HR • 180BL
390SD • 220RS • GREEN PVC
KANALINE SR • KANAPOWER AT



Thanks for
visiting us!

Genuine

Kanaflex®

Assemblies by

ABBOTT

300EPDM HOSE NOW AVAILABLE IN COLORS

GREEN/BLACK - BLUE/BLACK - RED/BLACK

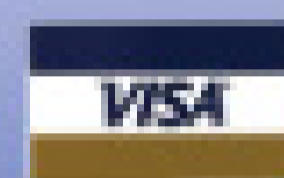

RUBBER COMPANY, INC.

1700 Nicholas Blvd. Elk Grove Village, IL 60007

www.pumperhose.com

1-800-852-1855 FAX: 847-952-0156

sales@pumperhose.com

Irrigation fittings are for irrigating – NOT vacuum.

How many dollars are you spending

SUCKING AIR?

Industry-proven, quality vacuum couplings from
Bandlock will put money into your pockets.



4" to 12" Male Coupler



Steel
Crown
4", 6"
and 8"
Press
End

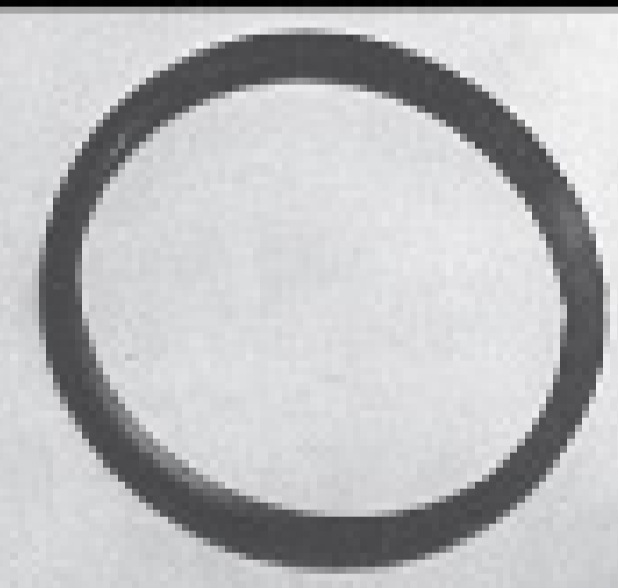

Hazardous Material
Profile Gaskets (Safety)

Recognized
as the
#1
Relief Valve
in the
World

CLOSE TOLERANCE
COUPLERS AND
FITTINGS BRING
"SAFETY" TO
YOUR WORK
PLACE.



Thank
you for
visiting
us in
Louisville



Special "Y" Reducers



BANDLOCK "Y"'s



Aluminum & Steel Pipe



BANDLOCK Reducers

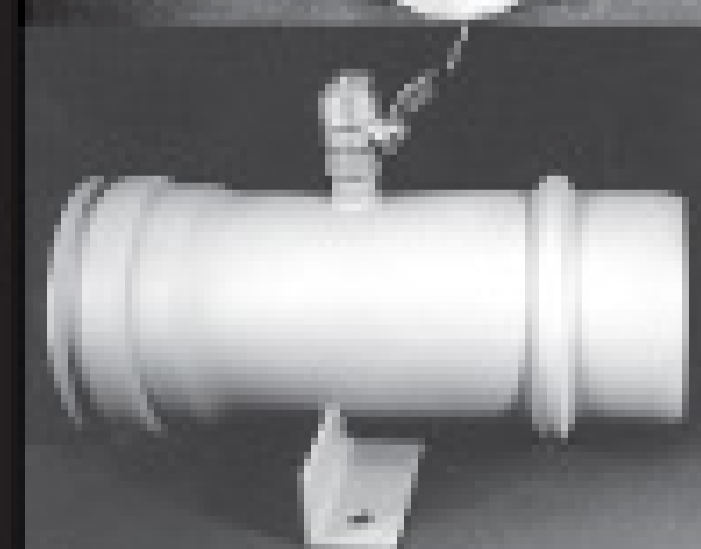

Wet Valve, 6",
360° Injected



Male and Female
4" to 12" End Plugs

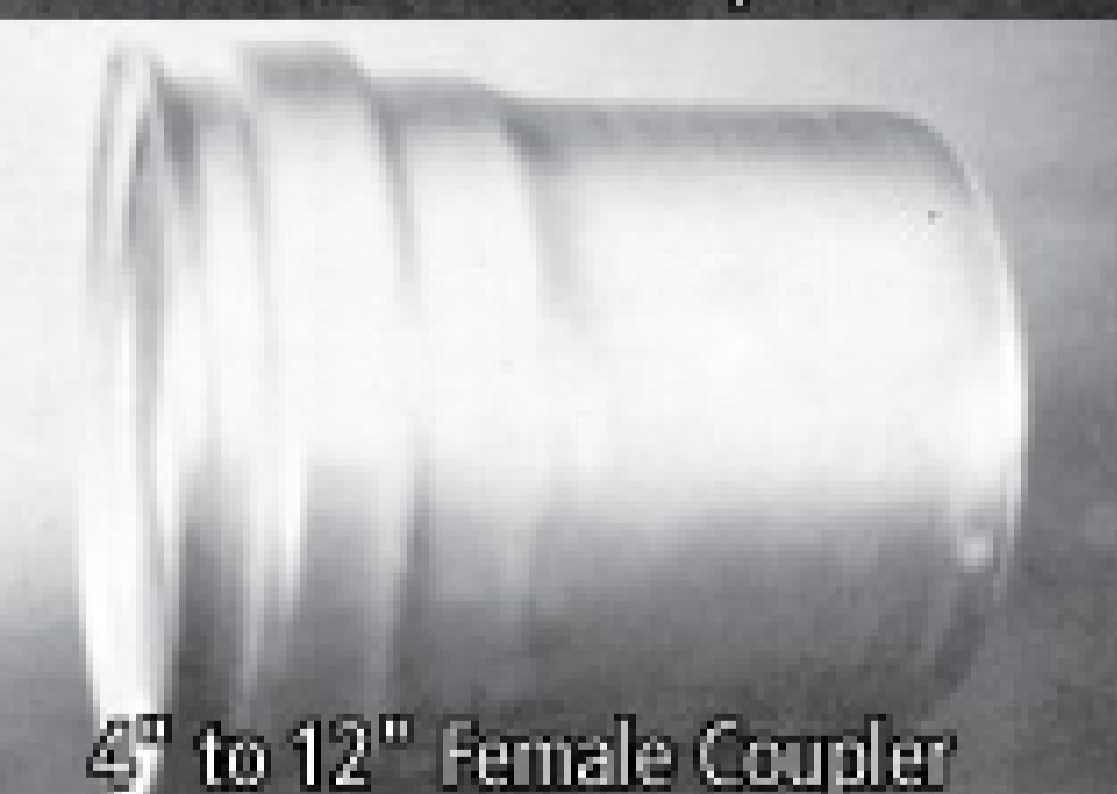

4" to 12" Female Coupler



4" and 6" High
Abrasive Bulk Nozzles



Rubber Gaskets

BANDLOCK Corp.

MADE IN THE U.S.A.

Call or fax today to
get your catalog!

1-800-659-2978

Fax: 909-930-2551

www.amesbury.com

SUPERIOR "QUICK" CONNECT VACUUM AND PRESSURE COUPLINGS AND ACCESSORIES



EZ Lift Clamps

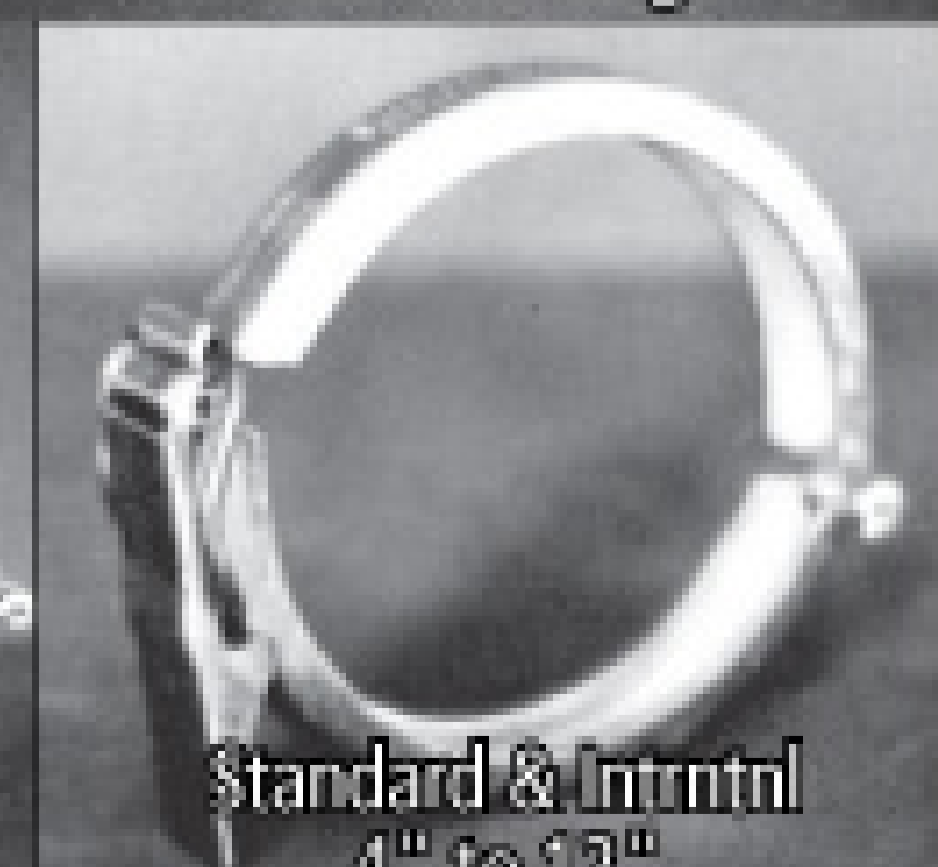

Standard & Internal
4" to 12"

ALUMINUM, STEEL and
STAINLESS TANKS manufactured,
assembled and serviced by quality
Imperial employees!



IMPERIAL
INDUSTRIES INC.
800-558-2945



**Over 28 Years of
Custom Tank Manufacturing
The Proud Tradition Continues....**

CUSTOM MANUFACTURED TANKS IN
STEEL, ALUMINUM AND STAINLESS

- STOCK UNITS:**
- (2) 2009 I.H. / 4000 Gal. Aluminum Tanks
 - (1) 2009 I.H. / 2500 Gal. Steel Tank
 - Ready For Delivery (Call For Details)

- STOCK TANKS:**
- 2500 Gallon Steel & Aluminum
 - 3600 Gallon Steel & Aluminum
 - 4000 and 5000 Gallon Aluminum

Call **Jim Stieber** or
Randy Tischendorf
for details!



**Introducing the
"Imperial Tradition"**

Call us for information on
the "Imperial Tradition,"
Wash Stations and Chemicals
for 2009

- Slide-In Units and
Service Truck Units
of various capacities
In-Stock!



V&H AUTOMOTIVE
Marshfield, WI 54449
Mark King

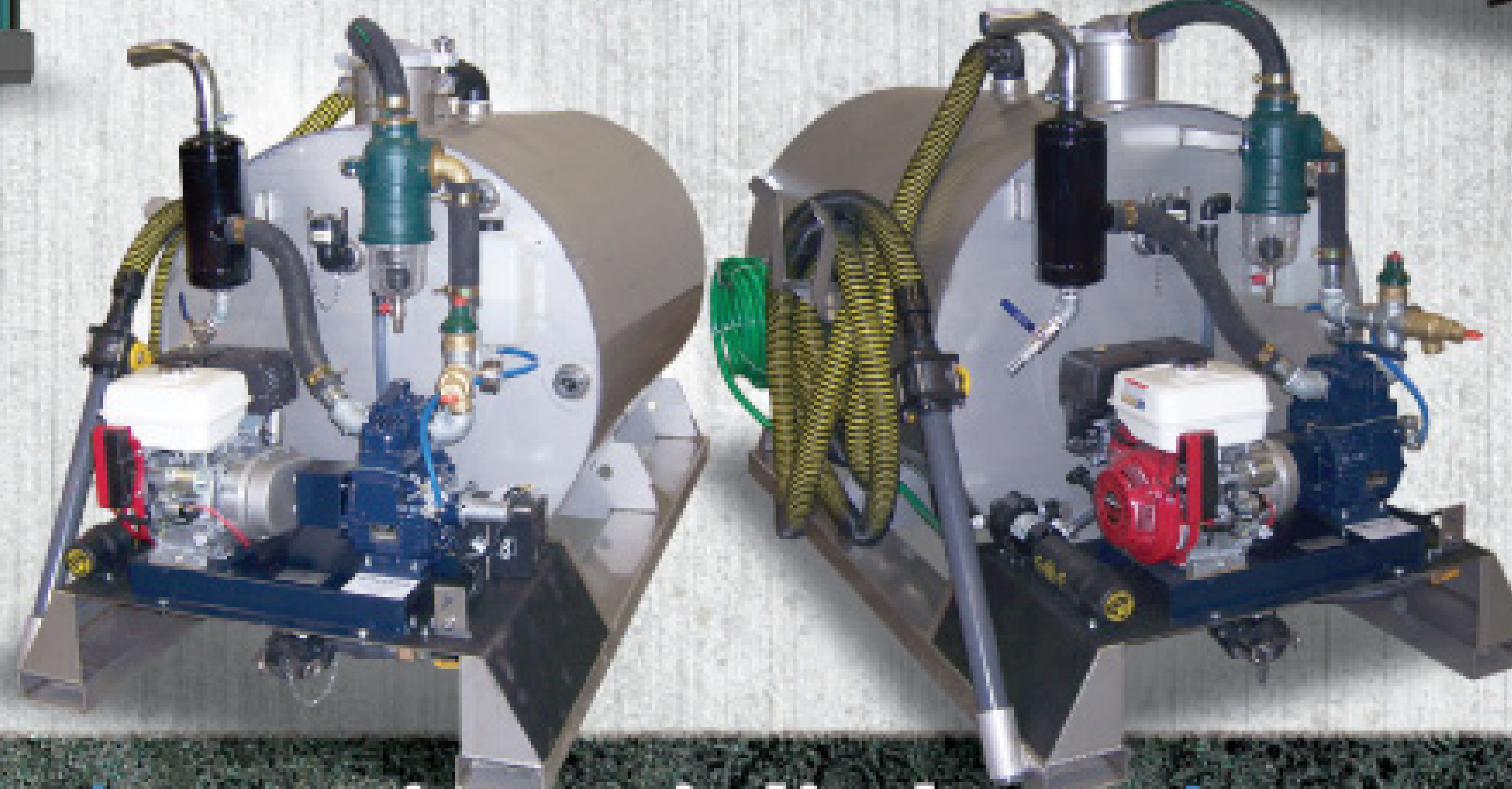

IMPERIAL
P.O. Box 1685
Wausau, WI 54402

800-722-7382, ext. 244 | www.imperialind.com | 800-558-2945, ext. 317

Michigan Grapples with Required Inspections, Diminished Land Spreading Opportunities

By **Scottie Dayton**

Proposed legislation in Michigan would add onsite systems to the Natural Resources and Environmental Protection Act as of January 2010. If passed, an amendment in the state senate would require inspection of certain onsite systems every 10 years.

At the urging of the Michigan Septic Tank Association, the amended bill also would require local governments that prohibit land application of septage to make a receiving facility available inside their boundaries, addressing statewide concerns over land application regulations. Meanwhile, legislation to create a state sanitary code is in the crafting stage.

Contractors already qualified to inspect conventional systems would be considered certified inspectors. Others would require state Department of Environmental Quality certification. Inspecting a conventional system would include preparing a report and submitting a copy to the system's owner and local health department.

The legislation also would prohibit the installation of alternative systems that were not approved by the DEQ or did not have a permit from the local health department. It authorizes the DEQ to work with organizations to develop educational materials on conventional system maintenance, and creates the On-Site Wastewater

Treatment System Advisory Council and the Alternative System Technical Advisory Committee.

The septic tank association has suggested a standardized inspection process and pumping of tanks before inspection.

IOWA

The Department of Natural Resources sent letters to some 700 unsewered towns, ordering them to stop discharging septic tank effluent into the state's waterways and to come up with some sort of sanitary engineering. However, towns with properly installed and inspected onsite systems could be exempt. State code requires effluent filters in septic tanks and a secondary form of treatment.

Properties with insufficient space or inadequate soils may have to group together to provide multiple-home systems. Some grant money is available from U.S. Department of Agriculture. Cost projections are \$2,500 to \$5,000 to upgrade a working septic tank and about \$7,500 to install a new system.

VIRGINIA

Residents in the Sleepy Creek watershed are eligible for a one-time \$150 reimbursement to help pay for pumping their septic tanks. The Chesapeake Bay Program, West Virginia Tributary Strategy Implementation Committee, West Virginia Conser-

vation Agency, and Eastern Panhandle Conservation District are offering the payments because the region has fecal coliform bacteria in its surface water.

The state Department of Health and Human Resources suggests an onsite system inspection every three years and a pump-out every three to five years. Funding is on a first-come, first-served basis. Call the West Virginia Conservation Agency Martinsburg field office, 304/263-4376, ext. 117.

ILLINOIS

The state Department of Public Health withdrew its proposed amendments to the Private Sewage Disposal Code and reopened discussions with the regulatory industry and certified local health departments to incorporate legislative changes that have occurred since the proposed amendments were drafted.

The action allows the agency to bring alternative technology, subsurface drip irrigation, portable sanitation and National Pollutant Discharge Elimination System requirements into compliance with state and federal laws.

MAINE

The majority of proposed changes to the Maine Subsurface Wastewater Disposal Rules are intended to simplify their application and enforcement. The changes would be effective April 1 upon approval by the Maine Center for Disease Control and Prevention.

The design flow for multiple-family dwellings is now calculated at 120 gpd for the first bed-

Rules and Regs is a monthly feature in Pumper. We welcome information about state or local regulations of potential broad interest to onsite contractors. Send ideas to editor@pumper.com.

room and 90 gpd for each additional bedroom. Other changes state that the Department of Environmental Health must approve septic tanks, and that aerobic treatment units must carry National Science Foundation Standard 40 certification and meet size recommendations provided by NSF.

The proposed changes would not allow reduction in the size of the disposal field. If the changes are passed, septic tanks installed 50 feet or less from the high-water mark or private potable water supply, or less than 150 feet from a public water supply, would need to be certified by the manufacturer as watertight or be tested in place.

WISCONSIN

The state Department of Revenue is auditing and taxing onsite installers retroactively for unpaid sales or use taxes on landscaping services. The agency contends that final seeding and grading falls under the landscaping category, which is a taxable service.

For example, if the dirt, fine grading, seeding, and mulching are 10 percent or less of the cost of the installation, and the contractor did not pay sales tax on the materials at the time of purchase, then the contractor owes back taxes. Contractors who can prove they paid the sales tax at the time of purchase do not owe additional tax.

FLORIDA

Proposed changes to the state administrative code would allow someone besides a septage disposal company to measure and certify a tank after pump-out,

The (Wisconsin) Department of Revenue is auditing and taxing onsite installers retroactively for unpaid sales or use taxes on landscaping services.

and to verify the tank's volume.

If the changes are passed, tank manufacturers would be allowed to install conduit ports in the lids at the time of manufacture and provide a method for sealing unused ports. Tanks also would have to be installed according to the manufacturer's instructions. Additional changes require dosing pumps to meet incorporated standards, enabling drainfields in moderately limited soils to be dosed up to four times a day.

The revisions would require engineers to consider waste strength when designing alternative systems that treat more than 1,500 gpd. Other proposals include paying application permit fees before final system approval is granted, and labeling alternative drainfield components and outlet filters with the manufacturer's name and model number in a location visible to inspectors.

MISSOURI

New regulations expected to be enacted by the state this spring allow onsite inspections for real estate transactions to include a microbiological test of private potable water wells, examinations of any visible portion of the water supply construction and review of well drilling reports. Inspectors renewing their licenses for the first time would need 20 hours of continuing education. Those renewing licenses for the second or subsequent times would need 12 hours.

Inspectors would need to notify property owners that they are not obligated to hire the inspecting contractor for repair or re-inspections. A proposed amendment establishes requirements for percolation testers, soil evaluators and onsite installers, and reduces the number of CEU hours necessary for license renewals.

Soil evaluators, percolation testers, and basic and advanced onsite installers renewing their

registration for the first time would need 20 hours of CEUs. Soil evaluators and advanced installers renewing for the second or subsequent time would need 12 hours. Basic installers and percolation testers renewing for the second or subsequent time would need eight hours.

WASHINGTON

Beginning in April, all onsite designers and inspectors scheduled for licensing exams must pass a take-home law and ethics exam.

The state Department of Health completed the draft On-site Sewage Tanks rule. The rule contains testing criteria to ensure that septic tanks are watertight and would require tank manufacturers to certify them as such. All tanks would have to be water- or vacuum-tested after installation to at least the invert of the outlet.

The rule would allow the DOH or the local health jurisdiction to require water-tightness testing two inches into the riser in sensitive areas, coarse soils, or when the tank is used for advanced treatment. The State Board of Health is expected to adopt the rule by the end of 2009. A one-year phase-in would allow existing tanks to be used and approvals to be issued.

The department also is revising its Large Onsite Sewage System rule, which is expected to become effective late this year. It would:

- Strengthen public health and environmental protections
- Provide more affordable options to small communities
- Expand treatment options and requirements
- Tighten operating and monitoring requirements
- Revise vertical separation, land area requirements, and existing design criteria
- Increase oversight and require owners to upgrade sub-standard systems over time. ■

Quality People Doing Quality Work

DOT Industrial Vacuum Hoist Units



DOT Industrial Vacuum Units



ASME & DOT Industrial Units

Portable Restroom Service Units



IN STOCK - 650/350 gal.
Call for Details
Ready for Immediate
Delivery -
Priced at
\$55,500

Mini Vac Trailers



DOT
Code
& Non
Code

Slide-In Units



Thank you M C Septic Services of TN
for purchasing this 450/250 unit.
More units in stock, please call for
details.



P.O. Box 1107 - 135 E Mile Road - Kalkaska, MI 49646
p: 231.258.4870 - f: 231.258.2019 - sales@marshind.com

800.952.1537 - WWW.MARSHIND.COM



Lely Waste Solutions, LLC

Temple, TX | 800 367 5359

THANKS TO
ALLIED AVIATION



THANKS TO
MARSHALL EXCAVATING



Temple, TX
800 367 5359
Fax 254 938 7204

www.lelywaste.com

Bruce Curry
bcurry@lelywaste.com
Earl Ballard
eballard@lelywaste.com

Save Time! Save Money! With a Stellar Hooklift!



- One truck can support numerous bodies, which cuts cost and maintenance
- Over 40 models available, capacities up to 65,000 lbs.
- One truck operator can, without leaving the cab of the truck, load and unload or change truck beds in less than a one minute cycle
- Patented dump/load interlock system
- Gravity type safety latches are used to prevent accidental detachment of the body
- Rugged rear body tie-downs and large over-sized rear hinge pins to insure stability
- Low maintenance
- Unlimited uses



Thanks for
visiting us!

The Stellar Hooklift Interchange System...Explore the Possibilities!



Our People.
Our Products.

800-321-3741 • www.stellarindustries.com



Top Line

Fuel pricing is back down...

The cost of plastic is back down...

**TOP LINE PORTABLE TOILET PRICE
IS BACK DOWN TOO!**



**Limited
time
offer!**

ARMAL Inc.

122 Hudson Industrial Drive - Griffin, GA 30224 - USA

Phone 770 491 6410 - Fax 770 491 9458

Toll free 866 873 7796 - armal-inc@armal.biz

Armal[®]
www.armal.biz/usa

Manufacturing

- *Stainless Steel*
- *Aluminum*
- *Code & Non-Code*



45 Years of Manufacturing Experience

*Vacuum Trailers for the
Liquid Transportation Industry*

Parts • Repair • Complete Pumping Systems

800-589-5254



www.acrotrailer.com • 417.862.1758 • fax 417.862.8084 • 2320 North Packer Road • Springfield, Missouri 65803

No COMPROMISE



Don't accept a substitute for quality. The Burks DC-10 is still the most popular, high volume washdown pump available.

With flow rates to 20 gpm and pressure to 40 psig, the Burks DC-10 is the pump of choice for filling and washing your portables.

Contact your local tank manufacturer for more info, or call us toll-free at:

800-699-7557

**ARMSTRONG
EQUIPMENT
INC.**

11200 Greenstone Ave. • Santa Fe Springs, CA 90670

562-944-0404 • Fax: 562-944-3636

www.vacpump.com

BROKEN TOILET? FIX IT UP!

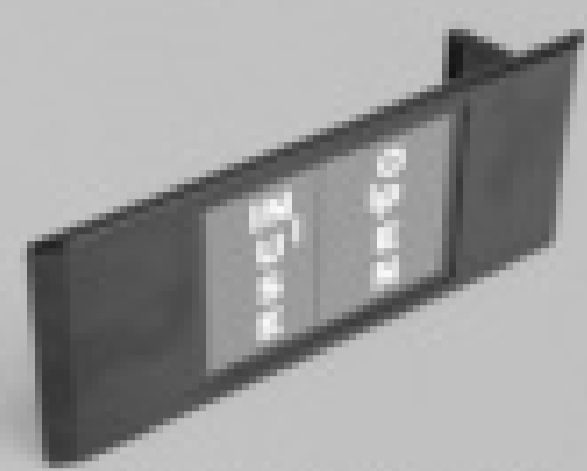

Indicator Handles

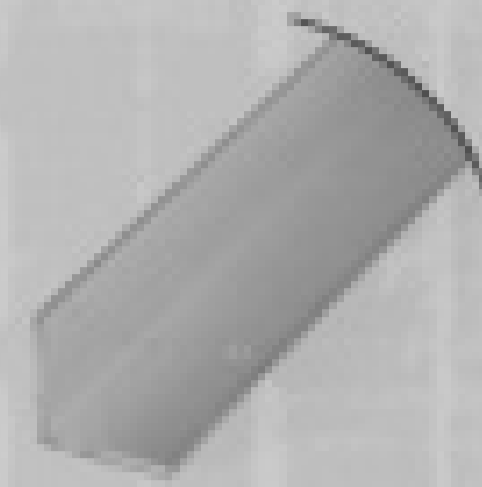

Thresholds



Skid Bases

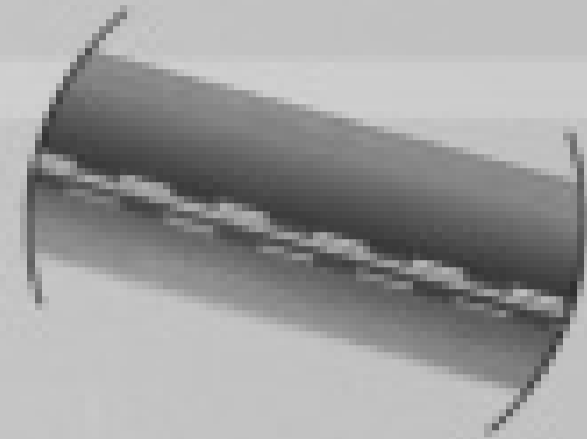

Piano Hinges

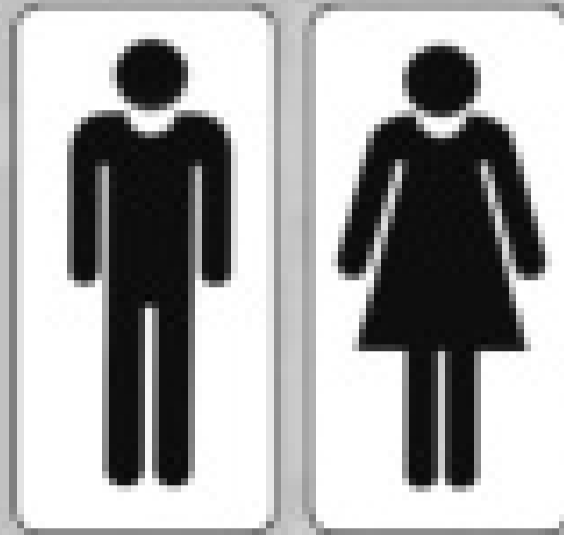

Decals and Signs



Spring and Cable Assemblies



Clips



Wind Cables



Toilet Seats



Hand and Foot Pumps



Replacement Roofs



Screws and Rivets

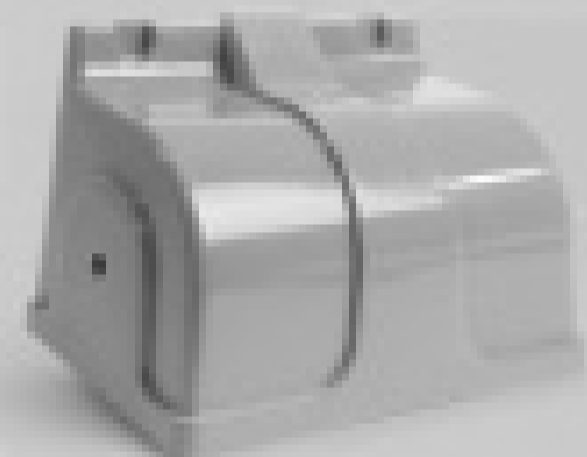

Toilet Paper Dispensers



Cam Lock Handles



Corner Moldings



Indicator Assemblies

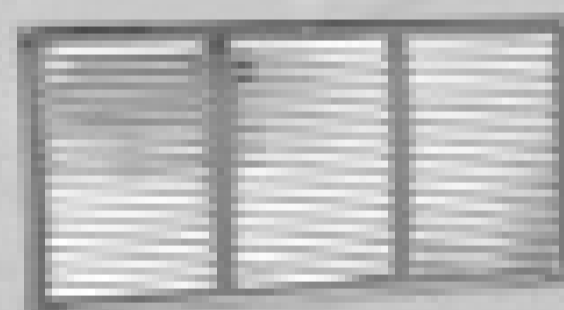

Vent Screens



Toilet Paper Rods



Call today to order:

1-888-935-1133
www.toico.com



You Can't Buy A Better Reel.

Hose Reels for Cleaning and Pumping

- ☑ High pressure washing and cleaning
- ☑ Sewer, septic, portable toilet cleaning
- ☑ Video pipeline inspection
- ☑ OE vehicles and aftermarket upgrades
- ☑ Extra rugged, long-lasting design
- ☑ Complete custom capabilities



Download or call for your FREE Guide to Ordering Pumper/Cleaner Reels
<http://go.hannay.com/U16>
877-467-3357

Hannay Reels®
The reel leader.

We Squeeze the Crap Out of Water™

Rotary Thickening and Dewatering

Simple systems that are totally enclosed, compact and easy to operate.



PH: 269-673-9559

www.primesolution1st.com

Made In USA

Pumper Show Special

\$90 in '09

\$90 Down, \$90 a Month for 90 Days

Get Pre-Approved Today!



2008 Pumper & Cleaner Expo Pheasant Hunting Adventure Winners

Everyone who completes an application through the end of the Expo will be entered to win the all expense paid 2009 Pheasant Hunting Adventure!

Call Jim Stekl
 For Details

866-769-2345

101 N. Main Ave Suite 215 • Sioux Falls, SD 57104
 Phone: 866-769-2345 • Fax: 605-271-7133



CAPITAL PARTNERS



www.yourcapitalpartner.com

Up to \$5,000 off all 2008 inventory.*

NEW AND PRE-OWNED SALES | RENTAL | LEASING | PARTS | SERVICE | BODY SHOP | FINANCING

If you're in the market for a refuse vehicle, make Rush Refuse Systems your resource. We have one of the largest inventories of work ready trucks in the country, representing the industry's leading brands. Whether you need to buy, rent or lease, we have a full spectrum of financial resources available. And, we support you through our Rush Truck Centers network of over 50 locations — with an extensive parts and accessories inventory, highly skilled ASE-certified service professionals and exceptional body shop capabilities.



Peterbilt 340 Standard Vacuum Trucks

Automatics and standards in stock ready to go to work. Non-code 3600 gallon Pik-Rite tank. Masport HXL400WV liquid cooled pump, aluminum hose trays, internal primary to secondary piping for clean mount. 10 yr tank warranty standard. Options can be added before delivery. Compare our standard specs to anybody!



Peterbilt 340 Industrial Vacuum Trucks

Automatics and standards in stock ready for delivery. DOT 407/412 3150 gallon Cusco units. Moro PM100 pump, hydraulic full opening rear, vibrator box, air actuated valves, full walkway with handrail, 20 ton dump capacity cylinder.



2008 and 2009 Peterbilt Cab and Chassis

Whether you're putting an old tank on a new truck, or custom building a truck the way you've always wanted, call us and choose from a wide variety of models and specs on the ground. Fast shipping available to your destination. Tank dealers and manufacturers welcome.



2009 Peterbilt 340 with 4000 Gallon Aluminum Vacuum Tank

Automatic or standard in stock ready to go to work. Imperial 4000 gal aluminum tank. Masport HXL400WV liquid cooled pump, Aluminum hose trays. Options can be added before delivery. Loaded out trucks! Two Stage engine brakes included.

877-661-4511

Refuse Sales Team: Gregg Wilkinson | Jason Guzauskas | Jesse Fullilove | Ryan Johle
refusesales@rush-enterprises.com | 8810 IH-10 East | San Antonio, TX 78219

*Prices listed here include discount and FET, and are subject to any state and local taxes. Discounts vary based on list price and age of vehicle. Prices subject to change. See your Rush Refuse Systems representative for complete details.

Refuse Systems



www.rushrefusesystems.com





Sludge Mate
& Poly-Mate

The Flo Trend® Sludge Mate® and Poly-Mate® form an economical and simple to use sludge dewatering system. The Poly-Mate® conditions sludge through the addition of polymer prior to the dewatering process which occurs in the Sludge Mate®. These units are designed to dewater sludge from a multitude of waste stream sources including: water and wastewater treatment plants, septic tanks, car washes, industrial sumps and lagoons, grease traps, rendering plants, and food processing plants. The Sludge Mate® and Poly-Mate® are available in a variety of sizes and configurations, and are built to custom specifications.



DEWATERING MADE SIMPLE.

Flo Trend Systems Tel - 713-699-0152
707 Lehman St. 800-762-9893
Houston, TX 77018 Fax - 713-699-8054
sales@fлотrend.com



MEGA Holding Tank

1250 Gallon Size



Options

Black Color • Level Alarm • Custom Fittings

LOW PROFILE Portable Holding Tank

100 • 210 • 300
Gallon Sizes

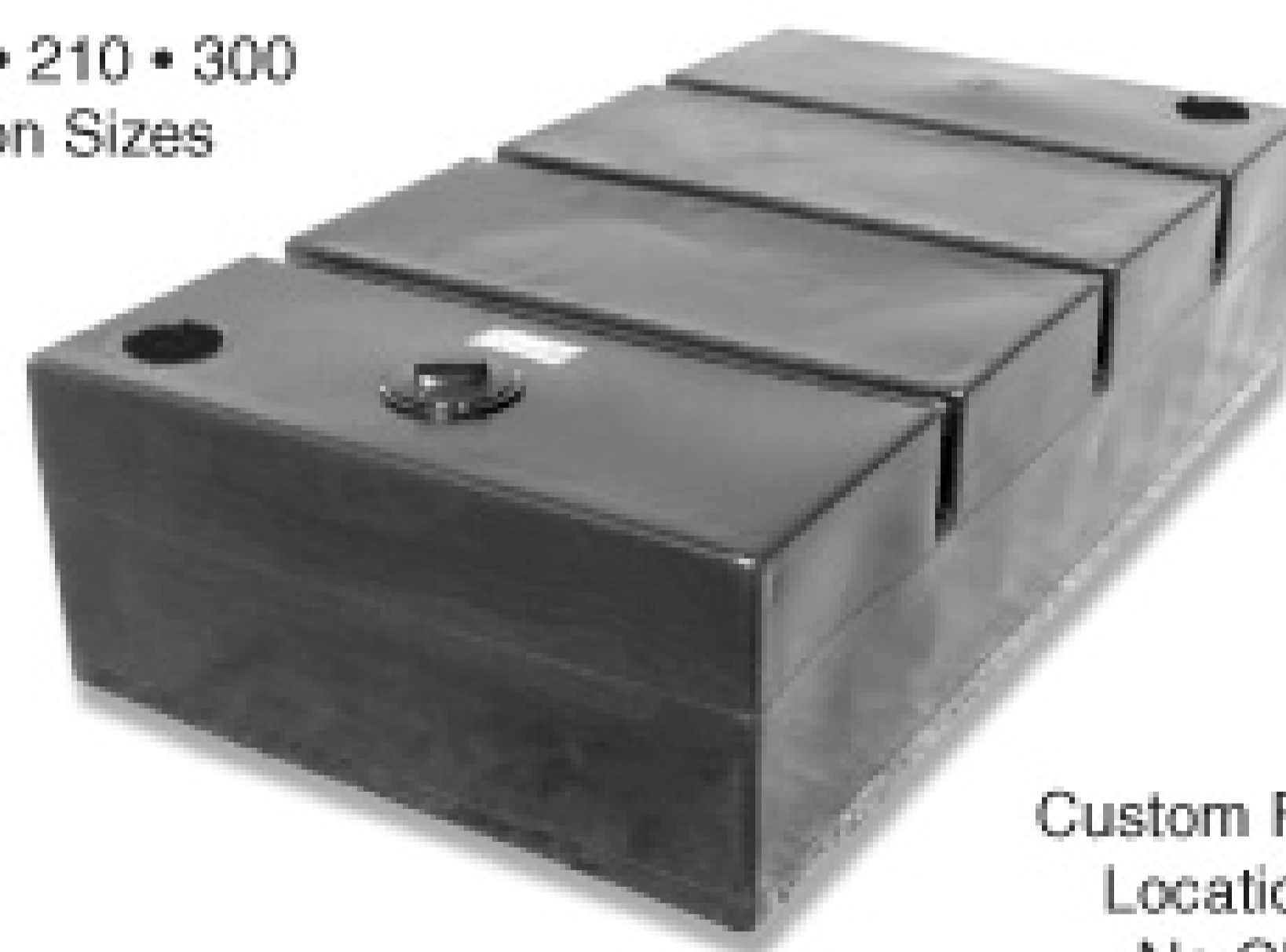

Custom Fitting
Locations at
No Charge

On-Site Water System

OSW PLUS —

- Tough 65 gal. Tank
- Removable cover for easy cleaning
- 115V On-Demand Pump 3.5 gpm 45 psi
- Low water shut-off
- GFCI Protected
- Filter
- Ships UPS

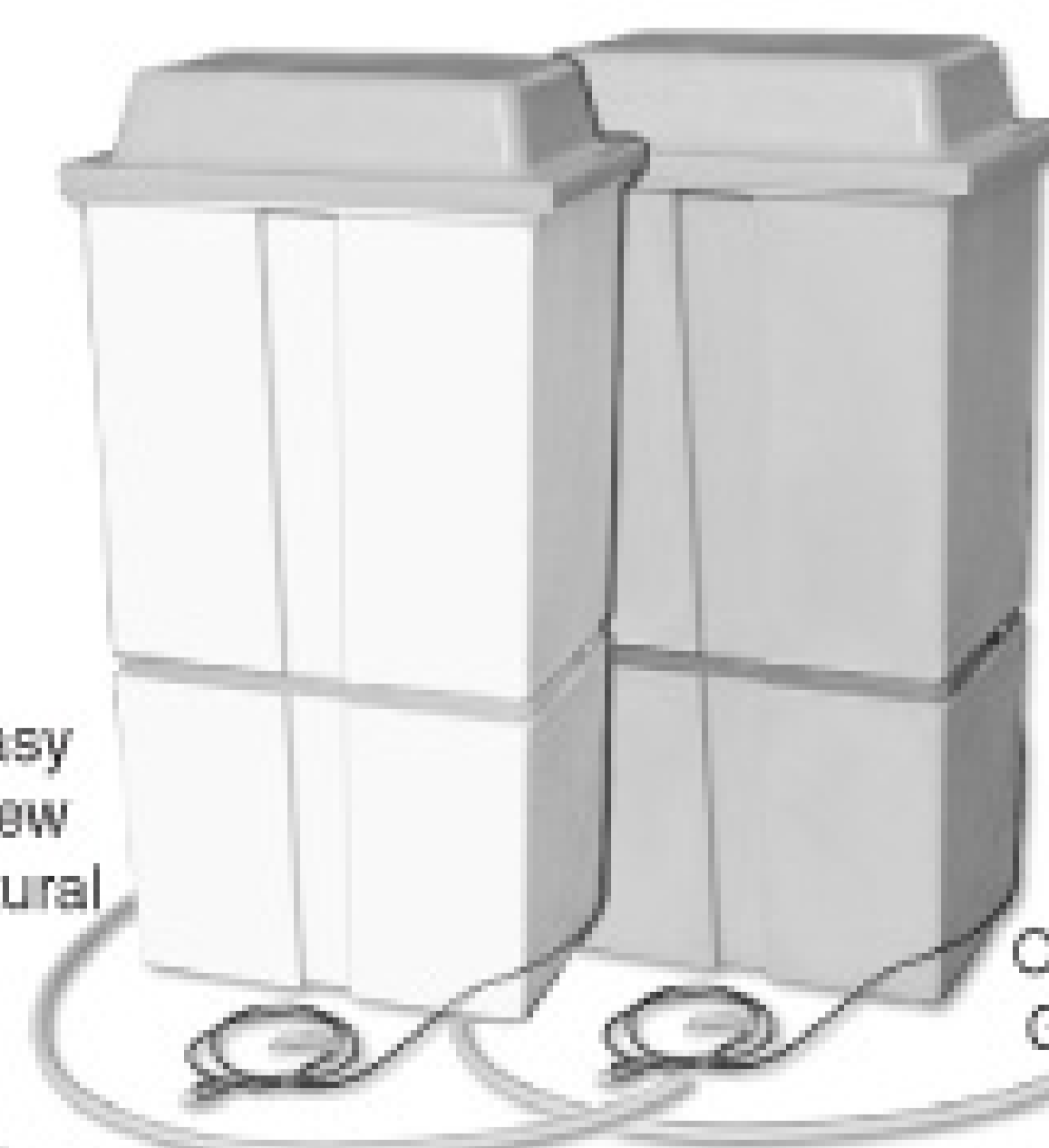

OSW DELUXE —

- Add external fill connection w/float valve

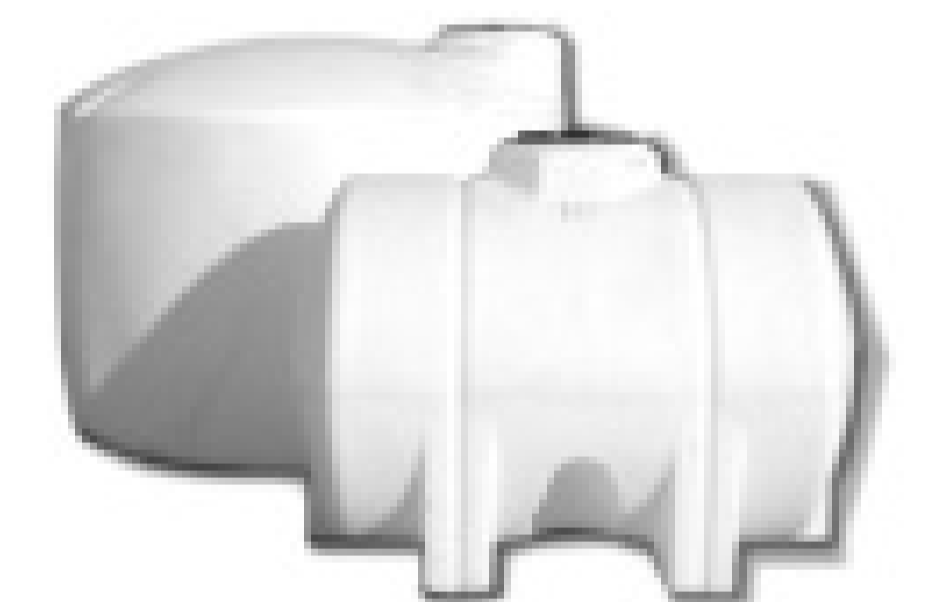

Bulk Storage and Transport Tanks



Septic and Cistern Tanks



Ball Valves and
Cam Lock Couplers

NORWESCO

Distributor Since 1987

Nationwide Shipping Points



KentuckyTank
Plastic Tanks and Accessories
1-888-459-8265
www.kentuckytank.com

LOADED PETES OR INTERNATIONALS YOUR CHOICE



2010 Peterbilt 340

\$109,900.00

US Funds – FOB Buffalo, NY
Many options available. Detailed specifications on request.

- Cummins Paccar PX-8 330 Hp
- Fuller 10 speed
- 18,000 front axle, 40,000 pound rear axle
- Air ride, factory air-conditioning
- Chrome bumper
- Polished aluminum rims all around
- Bridgestone tires
- Full-locking differential
- Power windows



2010 International 7500

\$102,900.00

US Funds – FOB Buffalo, NY
Many options available. Detailed specifications on request.

- International Maxxforce 10 350 Hp
- Fuller 10-speed transmission
- 18,000 pound front axle, 40,000 lbs rear axle
- Air-ride suspension, factory air-conditioning
- Combination engine/exhaust brake
- Polished aluminum rims all around
- Continental tires
- Thermostatically controlled heated mirrors



BOTH TRUCKS HAVE THE FOLLOWING OPTIONS:

- 3600 gallon capacity
- 396 cfm fan-cooled TSI 500 vacuum pump
- 2 baffles
- 20" top man-way, 20" rear man-way
- Heavy-duty primary & secondary shut offs
- Toolbox

- Sight glasses
- Heavy-duty rear bumper
- Full-length hose trays
- 6" discharge, 4" intake
- Complete factory specs available upon request

WE PAY BORDER CROSSING CHARGES • LEASING? WE CAN REFER YOU TO THE SPECIALISTS • OVER 40 YEARS IN BUSINESS

TRANSWAY
SYSTEMS INC.
PROFESSIONAL VACUUM EQUIPMENT

Toll-Free 800-263-4508

Tel. (905) 578-1000

Fax (905) 561-9176

DELIVERY SERVICE
AVAILABLE

314 Lake Ave. North
Hamilton, Ontario L8E 3A2

Firing On All Cylinders

Nathan Gay checks the oil on a 2009 Kenworth service truck built by Best Enterprises Inc. The truck is outfitted with emissions equipment required by the EPA's 2004 Tier 4 standards. (Photos by Kelly Roy)

Meticulous vacuum truck maintenance and regular fleet updates keep the wheels and profits turning for Maine's A-1 Environmental Services

By Mary Shafer

Nathan Gay wants to see a driver in the field with the vacuum pump working overtime rather than standing over a propped-open truck hood in the shop.

The owner of A-1 Environmental Services in Wells, Maine, figures that his company is generating income whenever pumps are whirring, and blowing out profits whenever a truck is down and out of service.

So a solid truck maintenance program and regular vehicle replacement are keys to the success of Gay's diverse company, which offers septic-pumping, portable restrooms and roll-off containers in Maine's more populated southern region.

A-1 continually rotates service vehicles out of its fleet and Gay has been unafraid of pulling the trigger

on truck purchases, even after controversial emissions systems upgrades hit 2008 models.

"I'd rather have a new truck partially paid for by selling an older truck in good shape, than waste time trying to unload a worn-out vehicle," he says. "And I don't want to have to spend lots of time keeping them on the road. I just don't make any money working on a truck."

In the past 4-5 years, A-1's growth prompted quite a few vehicle purchases. Gay doesn't expect that rate of growth to continue in the current economic climate, but believes things will pick up again in the near future. When that happens, he'll continue to regularly move old equipment out of his fleet, as a policy.

STARTED OUT YOUNG

Gay has spent half his life in the

"I'D RATHER HAVE A NEW TRUCK PARTIALLY PAID FOR BY SELLING AN OLDER TRUCK IN GOOD SHAPE, THAN WASTE TIME TRYING TO UNLOAD A WORN-OUT VEHICLE. AND I DON'T WANT TO HAVE TO SPEND LOTS OF TIME KEEPING THEM ON THE ROAD. I JUST DON'T MAKE ANY MONEY WORKING ON A TRUCK."

Nathan Gay



Profile

A-1 Environmental Services Wells, Maine

Owner: Nathan Gay

Founded: 2000

Employees: 9

Service area: Greater York County, Maine, and southern New Hampshire

Specialties: Septic and grease trap pumping, inspection and repairs; portable restrooms; roll-off containers

Web site: www.a-1environmental.com

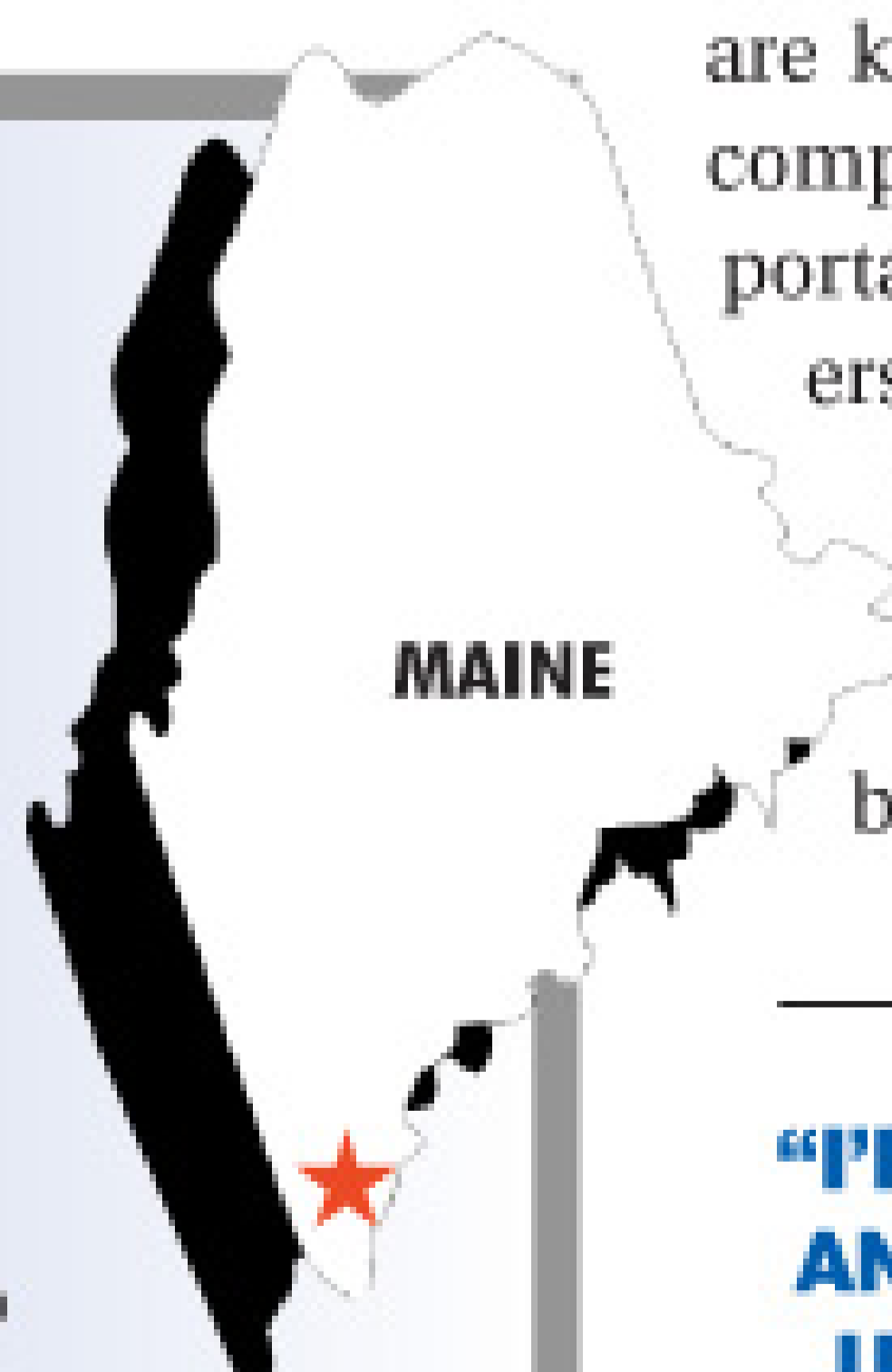



At left: Mechanic Keith Cluff removes the cover for the diesel particulate filter during a routine inspection. At right: Nathan Gay and Cluff check the exhaust temperature on the Kenworth T270's emissions system.

pumping industry, starting by driving a portable restroom route straight out of high school in 1992. Two years later, he went to work for the local municipal sewage treatment plant, but he missed the portables business. Soon, he bought a slide-in unit for his Dodge Ram 3500 and a small inventory of 18 PolyPortables Inc. Poly Standard restrooms and worked these as a side job.

In April 1996, his friend Bill Locke expressed a desire to retire from running A-1 Septic Tank Inc. Gay started working for him with the idea of buying him out, which he did in 2000. He renamed the company A-1 Environmental Services, with the goal of expanding into three distinct operations: septic, portables and roll-off containers. A-1's revenues split out percentage-wise at roughly 40 percent septic pumping, 30 percent portable restrooms and 30 percent roll-off rentals. The restroom division is known as Stop and Go Portable Toilet Co.

A-1 team members (from left) include Keith Cluff, Sean Dyer, Daniel Gray, Matt Chadbourne, Nathan Gay, shop dog Russell, Lisa Rivard, David Sands, Daniel Gay, Samuel Mooney and Nathan Gray.

IN THE GARAGE

Over the past several years, Gay has bought a lot of vacuum trucks and other vehicles to serve a wide variety of tasks. Along the way, he's developed a keen sense for how to manage and maintain a fleet for maximum profits and minimum hassles.

"I try to keep our fleet up to date. I monitor my depreciation, a good move tax-wise. Also, the weather makes our business seasonal, so those trucks need to be in top operating condition when we need them. We really need to perform during our very busy times, to get us through the slow times."

A-1's portables fleet consists of a 2009

Kenworth T270 service truck with a Best Enterprises Inc. stainless steel 1,500-gallon tank and Masport pump; 2002 International 4300 from Keith Huber Inc. with a 1,500-gallon steel tank and Masport pump; 2001 Ford F-550 delivery truck with a 450-gallon (300-gallon waste/150-gallon freshwater) slide-in unit with a Conde pump.

Septic service trucks include a 2007 Kenworth T800 with 3,600-gallon steel tank from Presvac Systems Ltd. and a Moro USA pump; 2004 Mack Granite truck with a Wastequip Cusco Inc. 4,300-gallon steel tank and Moro pump; 1998 Mack RD with 5,000-gallon Imperial Industries Inc. steel tank and Utile pump; and a 1984 Mack R with 2,500-gallon Boyd steel tank and Moro pump.

Industrial loading is performed by a 1993 Mack DM with a Vactor 1645 and Dresser Roots 10/21 pump. Roll-off containers are transported on a 2005 Kenworth T800 truck with Accurate Hoist Co. 75,000-pound hoist, and a 2001 Mack RD with the same hoist.

DRIVER PRIDE IMPORTANT

The 2009 Kenworth is outfitted with new emissions equipment required by the U.S. Environmental Protection Agency's 2004 Tier 4 standards. Equipment made for the new standards, first mandated in 2008 models, was greeted with skepticism by some



A-1's fleet includes a 2009 Kenworth T270 and 2002 International 4300 service trucks, 2001 Ford F-550 delivery truck, a 2007 Kenworth T800, 2004 Mack Granite, 1998 Mack RD and 1984 Mack R septic trucks, a 1993 Mack DM for industrial loading, and a 2005 Kenworth T800 and a 2001 Mack RD for transporting roll-off containers.

“HISTORY SHOWS WE’LL HAVE UPS AND DOWNS. CONTRACTORS WHO’VE STUCK TO SOUND BUSINESS PRACTICES WILL FIND THEMSELVES LESS STRESSED AND TURNING AROUND MORE QUICKLY. I BELIEVE IN THE FUTURE OF THIS INDUSTRY.”

Nathan Gay



Above: A-1’s T800 Kenworth roll-off truck, equipped with a 75,000-pound hoist, loads a 15-yard container. At left: A Kenworth T270 service truck with 1,500-gallon stainless steel tank by Best Enterprises and Masport pump transports a PolyJohn PJ3 restroom.

pumpers, who worried about higher sticker prices, unknown fuel economy and performance impacts.

Gay says the emissions equipment is bulky, and sometimes gets in the way at job-sites. He also says he’s found the emissions equipment makes the trucks less fuel-efficient than his older rigs. But on the whole, he’s glad he started making the switchover.

“Buying this truck was something of a risk,” admits Gay, “but that’s why I bought a 2007, too, so I could have pre-emissions equipment to fall back on. Still, we all have to deal with this equipment sooner or later, and I’m looking to the future. By the time there’s nothing else available, we’ll know how to handle it. Besides, it was more risky to run an old truck that might cause too much downtime.”

When it comes to making decisions about bells and whistles for a new truck, Gay takes into account features his drivers want. “I don’t let the guys go crazy, but if they’re going to spend 10-12 hours a day in a truck, I want them to be comfortable.” He listens to driver requests and solicits input when truck-shopping. He also gives drivers input into placement of hose carriers, storage and body design.

“I was primarily a Mack loyalist in the early 2000s,” Gay says, “but I switched to Kenworth because my guys love them. I don’t

pride, keep his wheels polished and take care of my investment. When customers see a nice, clean piece of equipment roll in the driveway, it’s impressive, and there’s value in that perception.”

SMART SHOPPING, TRUCK CARE

Gay counts on the Pumper & Cleaner Environmental Expo International to help him make big equipment buying decisions. “The show is definitely a must as far as seeing what’s out there, and what other people are doing,” he says. Gay knows which truck components he needs, but has a clipboard in his office where anyone is free to write down things they want investigated on the Expo floor. “I need a written list, because I get down there and it’s like Disneyland — I don’t know what to look at first.”

Since Gay places a high value on productivity, vehicle maintenance takes a front seat in his operation. “We try to keep the trucks new enough, through trade or sale, so we don’t have to do most of the major work. When we do have major jobs, we take them to the dealer. We experience about one major breakdown a year, and that’s when we start thinking about selling. The older

trucks don’t get run much. They’re around more for sentimental value.”

A-1 has its own mechanic to take care of preventive maintenance, oil changes, everything up to a major engine rebuild. “I wanted to get sizable enough so I didn’t have to do all that myself,” says Gay. “That was one of the largest motivators on growth decisions. It’s made my life good. I don’t have to be here at 9 p.m. anymore, putting vanes in a pump so we can do our work the next morning.” He hired the mechanic when the fleet reached 6-7 trucks.



Nathan Gay and Keith Cluff pump a 7,000-gallon tank at an ocean-side resort.



At left: Samuel Mooney loads one of the company's 400 Satellite Industries Tufway units on an International 4300. Below: Sean Dyer straps a PolyJohn PJ3 restroom to a Kenworth T270 service vehicle.



MORE INFO:

Best Enterprises Inc.
800/288-2378
www.bestenterprises.net

DRESSER Roots
877/363-7668
www.rootsblower.com

Imperial Industries Inc.
800/558-2945
www.imperialind.com

Keith Huber
800/334-8237
www.keithhuber.com

Masport Inc.
800/228-4510
www.masportpump.com

Moro USA East Inc.
800/383-6304
www.morousaeast.com

PolyJohn Enterprises
800/292-1305
www.polyjohn.com

PolyPortables Inc.
800/241-7951
www.polyportables.com

Presvac Systems Inc.
905/637-2353
www.presvac.com

Satellite Industries Inc.
800/883-1123
www.satelliteindustries.com

Wastequip Cusco Inc.
905/883-1214
www.wastequip-cusco.com

Westmoor Ltd.
315/363-1500
www.westmoorltd.com

Maine Pumpers Join Regulations Discussion

Maine is rewriting environmental regulations aimed at reducing the threat of accidental untreated flows, and a cadre of state pumpers, including Nathan Gay of A-1 Environmental Services, wants to be in the thick of the discussion.

The state government would like to restrict permissible volume at municipal treatment plants. Currently there's a statewide limit on waste from private haulers at municipal plants, up to 1 percent of a plant's designed capacity per day. With this limit already causing hardships for some pumpers, further reduction would not be good news.

Gay and three other pumpers in southern Maine dispose most of their waste at the South Berwick Sanitary District municipal treatment plant. They realized they had to do something to bring their plight to the attention of the lawmakers. So last November, the pumpers put competition aside and traveled to the Capitol in Augusta to meet with Maine's Department of Environmental Protection. They took advantage of a scheduled hearing to voice their concerns.

"We told them who we are, what we do and why this was going to have a negative impact on our businesses and our customers," recalls Gay. "We explained that having to find alternative disposal methods would force us to raise rates. In turn, people would have their systems pumped less often, ultimately resulting in more system failures."

Gay's background as a licensed treatment plant operator gave him credibility in pointing out that the 1 percent rule has no basis in reality, but is a purely subjective number. He urged the state to instead set waste restrictions for private haulers at municipal treatment plants on a case-by-case basis, based on scientifically acceptable nutrient removal rates and goals.

Maine pumpers are awaiting the rule change, wondering if their effort will have the intended results. "I think they're going to allow us to continue working as we have," Gay says, "maybe rewriting the rule so that the plant is in compliance, but not using the 1 percent rule for the entire state."

Regardless the outcome, the lobbying trip was a worthwhile exercise, according to Gay.

"I'm fortunate that the size of my company allows me to take time to get involved in these important issues. But in the future, it's going to be more important for every pumper to become active as regulations increase. You find the time to participate, because what you have to say can really matter in maintaining a business climate where operators can be profitable."

IN THE YARD

In addition to trucks, Gay maintains sizable portable sanitation and roll-off container inventories.

A-1's portables inventory consists of 550 units, made up of 100 PolyJohn Enterprises PJ3 standard restrooms; 400 Satellite Industries Inc. Tufway standard units; 30 Satellite Freedom 2 ADA-compliant units; and 20 PolyJohn Signature flushable restrooms with sinks. Gay used to assemble most units himself, but with such a large volume, he now has them delivered already assembled.

A-1 currently fields roughly 100 Wastequip Accurate roll-off containers. About 60 of them are 30-yard models, with the remainder split out pretty evenly between 10-, 15-, 20- and 40-yard sizes.

FORWARD THINKING

With a strong grasp on his equipment needs, Gay has kept his fleet updated without over-extending A-1. He expects his company to remain healthy through current challenging economic times, and emerge stronger than ever when the recession eases. He's clearly bullish on the liquid waste industry continuing to provide a vital and profitable service.

"History shows we'll have ups and downs," he says. "Contractors who've stuck to sound business practices will find themselves less stressed and turning around more quickly. I believe in the future of this industry." ■

FRUITLAND VACUUM PUMPS. SIMPLY THE BEST

We are the #1 vacuum vane pump servicing the oil fields across North America.

The reason is simplicity.

**We don't need gimmicks or water cooling to serve the harshest of applications.
Simple uncomplicated design that works.**

Features:

- Every Pump "Factory Tested"
- Low Maintenance Cost
- Continuous Duty
- Air - Cooled
- No Washboard
- Vacuum to 28 hg.
- Pressure to 30 psi.
- ISO Certified
- 2 Year Factory Warranty
- Automated Lubrication System
- User friendly Maintenance Features
- Models for Tanks sizes from 1000 to 12000 Gallons
- Drive option include; Hydraulic, Direct, Belt, and Right - Angle
- Proven in all environments (sub-zero to 100 degrees plus)



Thanks for visiting us!

Markets:

- Industrial
- Oilfield
- Septic
- Grease
- Environmental
- Wastewater

**Used and Proven by
World's Top Liquid
Vacuum Service Companies.**

**Vacuum Pump Training
Courses available*

Fruitland Tool & Manufacturing

" Committed to Quality, Reliability, and Guaranteed Performance "

Contact us today: **1-800-663-9003**
Visit us @ www.fruitland-mfg.com For more info.

Toll Free 888-207-2074

Fax (479) 770-6089

WILCOX TRUCK SALES, INC.



Lowell, Arkansas

SINCE 1978

I-540 Exit #78 & Hwy 71B

2 hours East of Tulsa or 1.5 hours South of Joplin

www.wilcoxtrucksales.com

1997 International Paystar 5000



\$79,250

M11 Cummins, 330 HP, 9 LL,
Hendrickson, 4.89 Ratio, Budd
Wheels, 208,766 Miles, 20/46
GVW, Quad Locks, New 100
Barrel, 4,200 Gallon Vacuum
Tank, New Juroop R260 Pump

Also, **1998 IHC 4700** with New

Approx. 2500 Gallon Vac. Tank, with (2) 21" Domed Top
Washout Manways, (1) 36" Domed Rear Cleanout, (2) 1/4"

Dished Baffles, New Juroop R260 Pump, DT466, Air Brakes, A/C

1987 International F9370

Big Cam Cummins, 350 HP, 9 Speed,
Hendrickson Suspension,
236" WB, Budd Wheels,
70 Barrel Vacuum Tank,
Gardner Denver Pump



\$39,250

We've got your
Septic Tank **COVERED**
and Covered **"RIGHT"**



**Hedstrom
PLASTICS**

419-282-5559

CALL TODAY!



Fits Standard 18" and 24"
Double Wall Corrugated Pipe

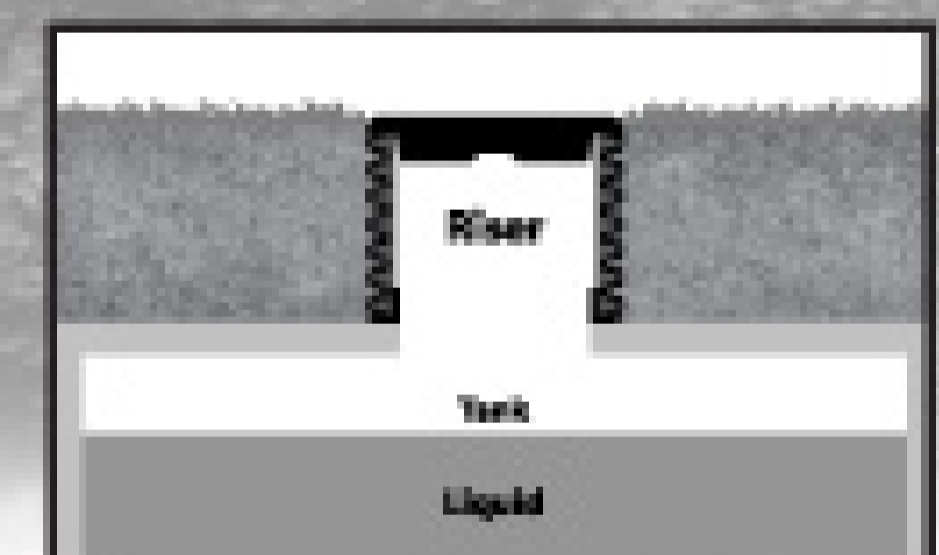

Double wall pipe
furnished by installer

Stop Infiltration with a
New Tank Adapter



Now with Safety Screws

- Strong green heavy wall polyethylene yet lightweight
- Fits standard 18" & 24" double wall corrugated pipe
- Gaskets and safety hardware included with all covers
- Can be filled with sand on site for added weight
- Can be customized with your name embossed or stamped



Thanks for visiting us!

www.hedstromplastics.com

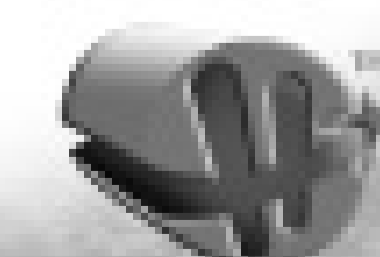

**Hedstrom
PLASTICS**

1401 Jacobson Avenue
Ashland, Ohio 44805



Our **VALUE** goes deeper than you realize.

When it comes to portable sanitation solutions, WALEX delivers much more than blue deodorizers and accessories. We're giving you **innovative research & development** that has set all the current standards for excellence. You're getting **proprietary breakthroughs** that our competitors can only emulate. When you choose WALEX, you're not only getting **the best on the market today** — *you're also supporting your industry's future.*



For more information, contact us at **910.371.2242**, toll-free **800.338.3155**
or visit our website at **www.walex.com**.

Longhorn Tank Co.

The Solution for All of Your Pumping Needs



130 bbl Steel Trailer



7,000 Gallon Aluminum Trailer

Call or Email Us For a Quote Today

800-422-9840

sales@longhorntank.com

PO Box 1147 Gravette, AR 72736

Fax 479-787-6935

NUCONCEPTS

MANUFACTURER OF QUALITY PORTABLE RESTROOMS AND SINKS



Thank you for visiting us in Louisville

Dual VIP Restroom Trailer

From \$9,841

Ideal for:

- Weddings / Parties
- Sporting Events
- Food Festivals
- Community Events
- Restroom Remodeling
- Movie Production

Features:

- Solar Powered
- Self-contained
- Flushing, china toilet
- Enclosed sink
- Power Converter (option)
- Air-conditioning (option)
- Interior Heater (option)
- Sink Water Heater (option)



1737 S. VINEYARD AVENUE • ONTARIO, CA 91761

PHONE 909-930-6244 • TOLL FREE 800-334-1065 • FAX 909-930-6237

www.NUCONCEPTS.com

ERICKSON

TANK & PUMP

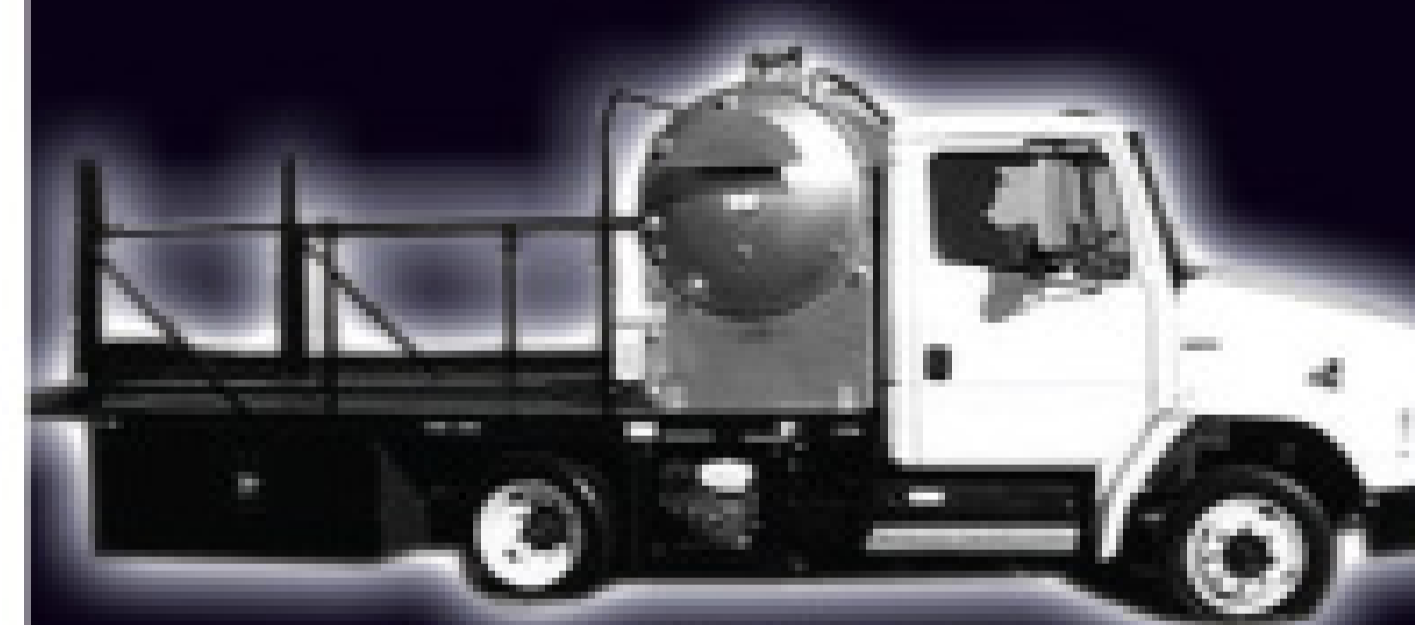

PORTABLE TOILET SERVICE TRUCK



WASTE COOKING OIL SERVICE TRUCK



SEPTIC SERVICE TRUCK

Check Our Web Site for Current Inventory!

"Tanks" for your business!

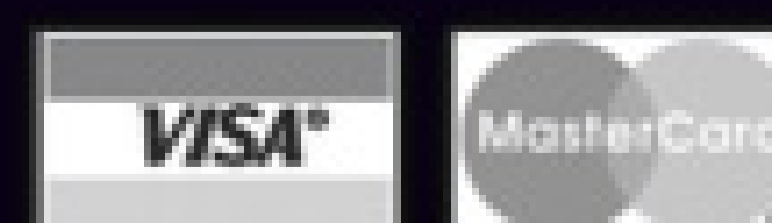

509.785.2955

WWW.ERICKSONTANK.COM

HURRY, ENDS 3/31/09!



NEW COLORS!

BLUE AND BLACK



VARCO FLEXI-JOINT

HOSE BREAKING OFF AT TRUCK?
YOUR CHOICE SAME PRICE

3" \$45.95
4" \$59.95



VARCO TUFF-JOINT



NEW COLORS!

RED AND BLACK

BUY BULK AND SAVE!
EPDM SUCTION BULK
100 FT ROLLS



GET IT IN COLORS
SAME LOW PRICE

2" \$2.19
3" \$3.69
4" \$6.59
6" \$11.35
\$1.59 \$2.70 \$4.85 \$9.95

EPDM SUCTION CPLD
M X F QUICK CONNECT



GET IT IN COLORS
SAME LOW PRICE

INCLUDES
FITTINGS!



3" X 20' ~~\$84.95~~ **\$76.95**
3" X 25' ~~\$101.95~~ **\$89.95**
3" X 30' ~~\$117.95~~ **\$105.95**
3" X 33' ~~\$129.95~~ **\$109.95**

NEW PORTABLE TOILET HOSE!
PORTA-TUFF HOSE
A Varco Exclusive!



2" X 25' **\$79.95**
2" X 30' **\$93.95**
2" X 35' **\$109.95**
2" X 40' **\$124.95**

- NO CUFFS!
- 100 FT LGTHS
- EASY REPAIR!
- MOST FLEXIBLE HOSE WE HAVE!

TIGER TAIL CPLD M X F QUICK CONNECT



INCLUDES
FITTINGS!

2" X 25' ~~\$96.75~~ **\$74.95**
2" X 30' ~~\$113.00~~ **\$88.95**
2" X 35' ~~\$129.75~~ **\$103.95**
2" X 40' ~~\$145.50~~ **\$117.95**

VALVES

LEVER VALVES

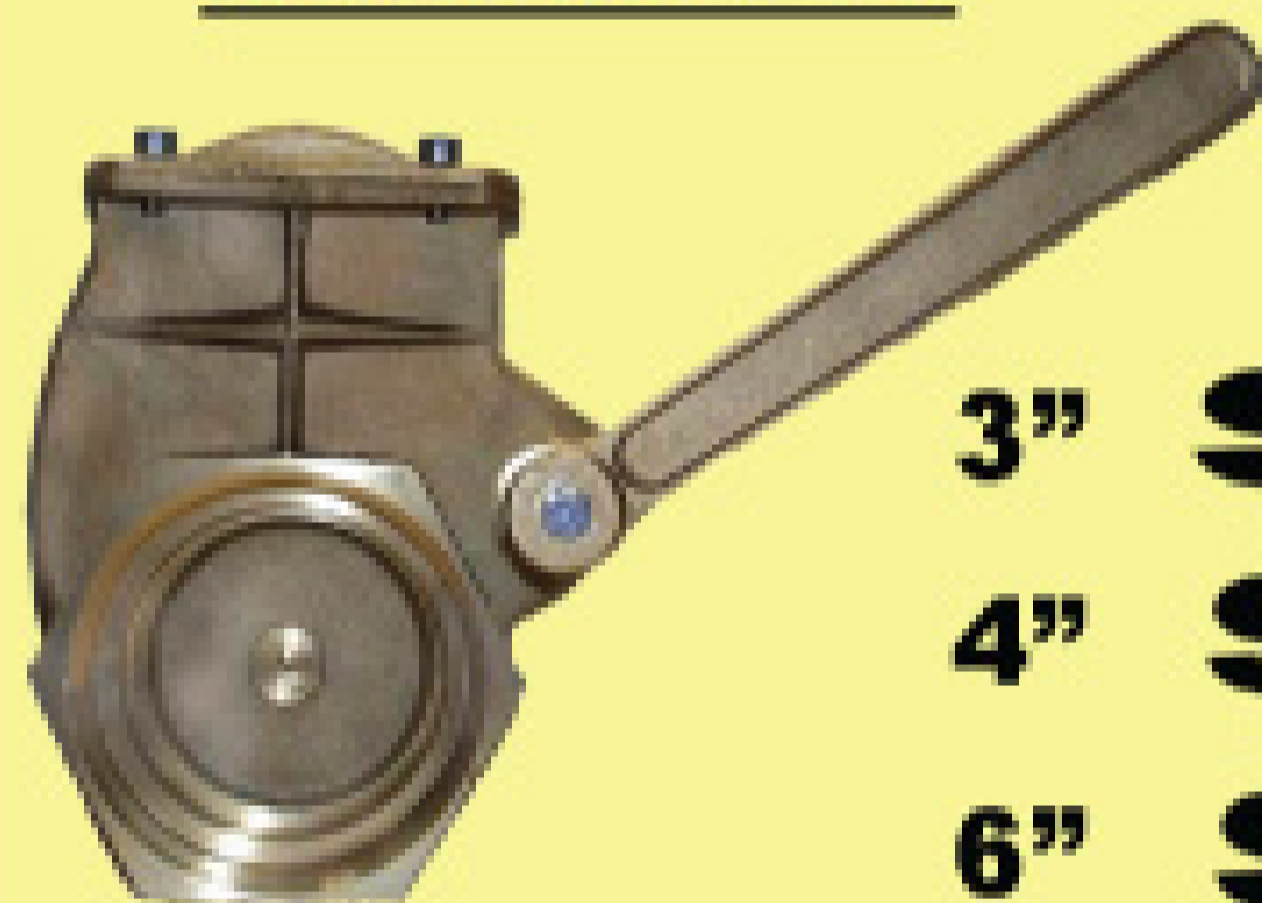

3" **\$94**
4" **\$138**
6" **\$260**

SAVE MONEY- PROTECT YOUR FITTINGS!

SAFETY LOCK

2" **\$1.95**
3" **\$2.50**
4" **\$2.95**



SAFETY BUMPS

COMFORTABLE HANDLE
SAFEGUARDS YOUR FITTINGS

2" **\$18.95** MXF SET
3" **\$23.25** MXF SET
4" **\$36.25** MXF SET

JUROP R260

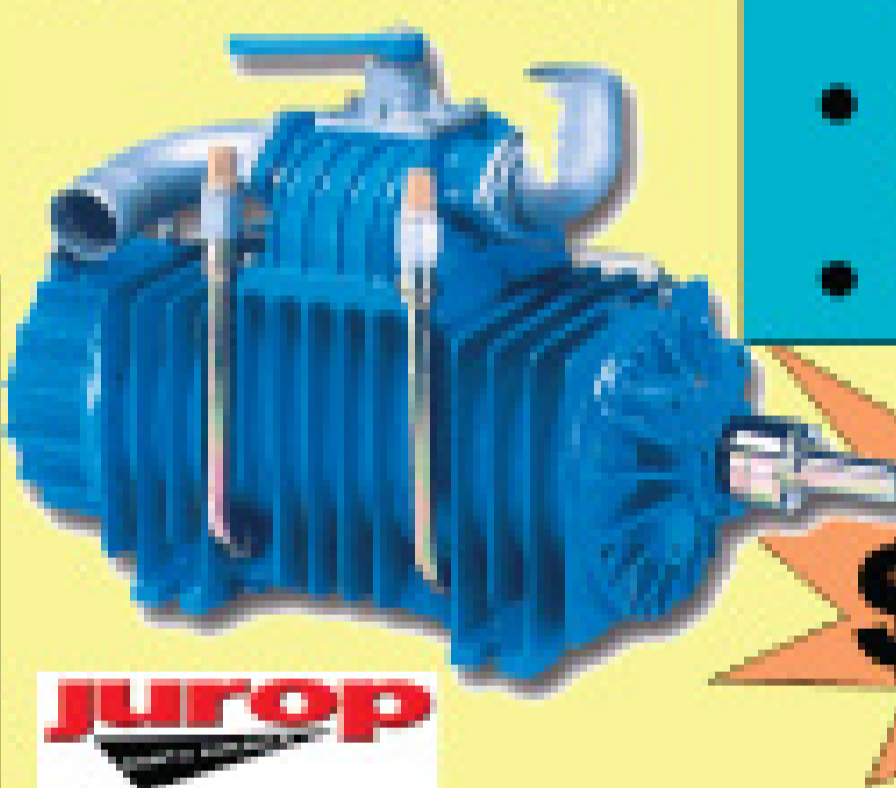

- 383 CFM
- 18" CONTINUOUS DUTY
- BALLAST PORT COOLING
- AUTOMATIC OILER

\$2495

JUROP PN58



- 230 CFM
- FORCED OIL LUBRICATION
- 3" CONNECT

\$1495

JUROP PN23



- 93 CFM
- FORCED OIL LUBRICATION
- 3" CONNECT

\$1050

COUPLINGS AND REDUCERS



100'S
OF
THEM!



FEMALE X MALE REDUCER



3" X 2" **\$17.85**
4" X 3" **\$26.25**
6" X 4" **\$45.95**

VAC TRUCK ACCESSORIES



1 1/2" BRASS
VACUUM RELIEF

2" **\$173.25**
3" **\$173.25**



\$28.95



BRASS PRESSURE
VALVE

1 1/4" **\$29.95**
1 1/2" **\$35.95**
2" **\$45.95**



VACUUM PRESSURE
GAUGE

- 0-30 Vacuum
- 0-30 PSI
- Liquid Filled
- 1/4" Male NPT

2.5" Face **\$13.95**
4" Face **\$40.95**



2" **\$173.95**
3" **\$235.95**

MANHOLE HOOKS
Available in
standard or 90 deg



24" **\$17.95**
36" **\$26.95**



PVC ROUGH
GRIP GLOVES
Less than
\$1 per pair!

\$11.95 /dz

SLUDGE HOE
\$62.50
\$56.95

SPOONS
Includes Fiberglass Handle!
from **\$99.75**

SCRAPERS
from **\$45.75**

FREE
CATALOG



SHOP ONLINE AT WWW.VARCOPUMPER.COM

OPEN LATE NITES AND WEEKENDS!

TOLL
FREE

866-872-1224

SOURCE KEY
3P9



Shawn House's grandfather Milbourne House began manufacturing burial vaults in 1968. Two years later he diversified into septic tanks. Today, All Star Septic Tank Pumping produces tanks that range from 300 to 1,500 gallons in size. Below: Lans Vines pours the top half of a 1,000-gallon septic tank and finishes the concrete. (Photos by Doug Smith and courtesy All Star Septic Tank Pumping)

COVERING the Bases

Missouri-based All Star Septic manufactures the tanks, installs the systems, pumps the waste and places portable restrooms at construction sites

By Mary Shafer



You could say Shawn House literally came up in the septic waste management industry. His father created a septic tank manufacturing firm out of Shawn's grandfather's concrete vault and grave digging company. At age 19, House could see from all the septic tanks they were installing that his family's business was missing out on the related pumping work, which no one was doing.

With a homemade vacuum truck and an entrepreneurial spirit, the younger House built a thriving business that has expanded into portable restroom service and made him one of the larger players in his market. From these humble beginnings, House continually improves his lot by staying abreast of technological innovations and industry trends, hands-on hiring and management, and trying to raise professional practices in his area through employee training and customer education.

NATURAL PROGRESSION

House's grandfather Milbourne House started the family burial vault business in 1968. In 1970, he diversified, buying a form to pour septic tanks. Septic tank manufacturing and installation began to take off, and in 1976, he and his son Michael House sold the vault business.

Shawn House followed his father into the family business, and by his mid-teens noticed that no one was pumping the

tanks they installed. "Everyone was always asking me why we didn't get into the pumping business," he recalls. "I told my dad and grandpa that in the winter time, when sales are down for septic tanks, pumping would pick up the slack, and business referrals would flow between the two." It was his first entrepreneurial insight.

House saved his money and in 1991 — at age 19 — bought a 1,500-gallon stainless steel Better Built tank that had been on a farm truck. It came with a Pierson 240-cfm pump. He changed valves and fittings to accommodate septic pumping hoses and mounted it on a 1969 International chassis bought from the local fire department. Then he fabricated hose trays.

"If you don't count my time, I had \$1,400 in the tank and truck to get started," he says, chuckling. "I made my money back in a year."

Two years later, House replaced the old truck with a 1988 International L6X4 and transferred the tank to it.

A few years ago, House's business instincts kicked in again and he saw a niche open up in his market on the southwestern outskirts of St. Louis. A strong economy was spurring growth in tourism, which created a need for vacation homes. As developments sprang up, All Star expanded into portable restroom rentals to service these with the launch of its All About Potties division.

"I ENCOURAGE MY DRIVERS TO CALL IN AND TALK ABOUT A SITUATION THEY HAVEN'T ENCOUNTERED BEFORE. BUT THEY'VE ALL BEEN WITH ME A WHILE, SO THEY'RE PRETTY WELL UP TO SPEED. MOSTLY, YOU NEED TO EDUCATE THE PROPERTY OWNER ABOUT THINGS LIKE GETTING ROOTS OUT OF THEIR SYSTEM, HOW OFTEN THEY NEED TO GET PUMPED OUT, AND WHAT TO LOOK FOR IN A TANK THAT SIGNALS TROUBLE."

Shawn House

House tested the market by renting 50 units from a colleague, he says. "But they were old and trashy, and I wanted to have a better image. So I went to the Pumper & Cleaner (Environmental Expo International) and got 100 top-of-the-line units." All About Potties now fields 102 units from Satellite Industries Inc.: 100 Tufway standard restrooms, and two Liberty ADA units. They also offer four PolyPortables Inc. sinks.

VARIED SERVICES

Portables now make up about 10 percent of total revenues, divided about evenly between contractor and event customers. House expects volume to continue growing.

Last year, he signed a three-year contract with a developer at nearby Lake Hannah to service rustic accommodations for weekenders and about 30 year-round residents. "They're not allowed to have septic or wells, so they don't even have running water." The development's association pays on a monthly basis for 61 units year-round.

About 15 percent of All Star's revenues are from septic and grease trap pumping. Some 65 percent of the income still comes from septic system installation, with tank manufacturing declining to about 10 percent.

Vehicles still include the 1988 International, which now pulls a 30-foot restroom transport trailer, plus a 1991 GMC Topkick vacuum truck carrying the Better Built 1,500-gallon tank with the Pierson pump. There's also a 1997 Freightliner with a 2,500-gallon Indiana Vacuum Tank Truck Inc. stainless tank and a Masport 350-cfm pump; a 2005 Ford F-650 with a 1,500-gallon Better Built stainless steel tank and a Masport 350-cfm pump. Portables are hauled and serviced with a 2002 Ford F-250 with a homemade single restroom slide-in unit, which sometimes pulls a 16-foot gooseneck trailer. A 1999 Dodge one-ton service van and a 1987 Kenworth flatbed with a military surplus boom to set septic tanks round out the fleet.



A good-looking truck portrays the proper image for All Star Septic Tank Pumping. This 1997 Freightliner FL70 carries a 2,500-gallon tank. At right: Shawn House inspects a septic system to make sure it's working properly.

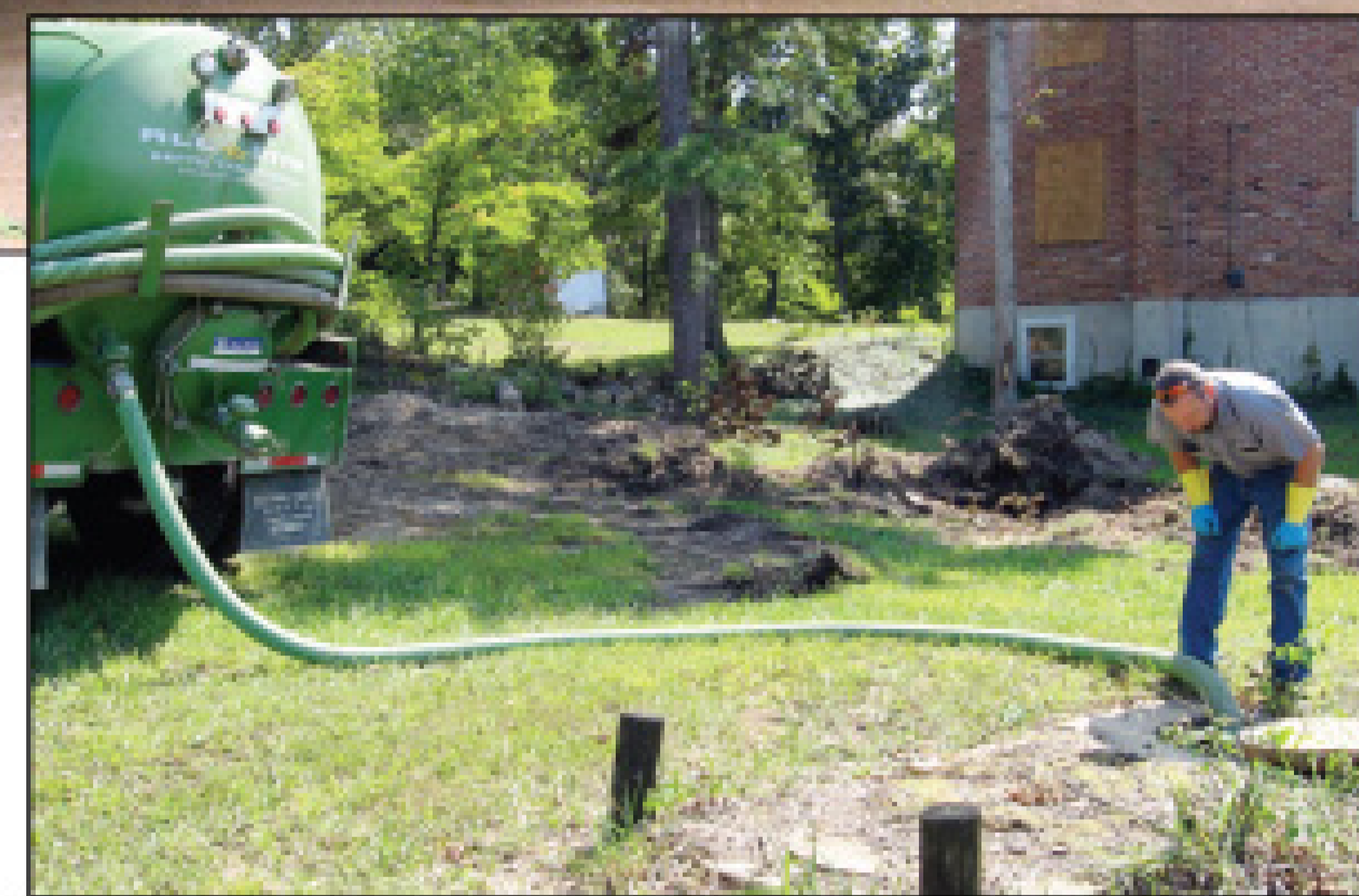

COMMERCIAL PUMPING

Commercial pumping customers include nursing homes, service stations and holding tanks at nearby lake developments.

All Star has a large grease collection account, a meat packing plant. Disposal goes over the state line to a private Illinois rendering company. It's a 100-mile run one way, so House prefers to pay for one-day-a-week service from the rendering firm. All Star supplies a mobile dewatering press and storage container, which it picks up. It pumps the grease on the first of every month; the rendering company delivers the press immediately after. If All Star gets any other grease jobs mid-month, they put the waste into a holding tank until the press arrives again.

The company also pumps out 18 package treatment plants for surrounding municipalities. All Star has access to 300 acres of sand flats left over from old lead mining operations for land application. The mining company was required to remediate the brownfield, which All Star's application now fertilizes so grasses can grow there. State law requires that All Star add 50 pounds of lime to stabilize every 1,000 gallons of waste.

House believes this disposal option will go away before long. "I think the government is going to get really strict about reporting,



and will eventually allow no land application. I'm going to get out ahead of that by looking at dewatering equipment, so I can start dumping at a treatment facility." He plans to get a larger hauling truck so he can carry dewatered sludge to a plant, for which he has already begun the permitting process.

RAISING STANDARDS

House's long-term goal is to increase his customers' understanding about what he does, as well as raise the professionalism of his company. "I encourage my drivers to call in and talk about a situation they haven't encountered before. But they've all been with me a while, so they're pretty well up to speed. Mostly, you need to educate the property owner about things like getting roots out of their system, how often they need to get pumped out, and what to look for in a tank that signals trouble."

Profile

All Star Septic Tank Pumping Bonne Terre, Mo.

Owner: **Shawn House**

Founded: **1968**

Employees: **6**

Annual billings: **\$1.5 million**

Service area: **100-mile radius**

Specialties: **Septic pumping and installation, portable restrooms, septic tank manufacturing**

Affiliations: **Bonne Terre Chamber of Commerce, National Federation of Independent Business**



"I THINK THE GOVERNMENT IS GOING TO GET REALLY STRICT ABOUT REPORTING, AND WILL EVENTUALLY ALLOW NO LAND APPLICATION. I'M GOING TO GET OUT AHEAD OF THAT BY LOOKING AT DEWATERING EQUIPMENT, SO I CAN START DUMPING AT A TREATMENT FACILITY."

Shawn House

Most of the older homes in his area have Class I jet aeration systems. House's installation experience has made him familiar with such multi-chambered tanks, and he uses that knowledge to help diagnose problems. "I'll dig it up and show customers why theirs isn't working. It's usually because a different chamber was pumped previously and now another one is full, but they just think it's all one big compartment."

When these systems were originally built, risers weren't installed, but now state law requires them, so they're easier to service. "Once I get the tank dug up to show people what's going on, I tell them we might as well install a riser to bring it up to code and make it easier to service," House says. "They usually see the advantage in not having to have their yards dug up every time we pump."

This would be more of a concern with property owners, says House, if they were practicing proper pumping frequency. "People don't really know the right schedule for pumping to keep their tanks in good shape. I have my drivers ask a series of questions about the number of people in the house, whether they have a lot of girls who are in the bathroom a lot, what kind of toilet paper they use. I explain why these things are important, to help them understand better practices." Most of his customers moved from outside the area and ask how to take care of their systems, providing All Star a teachable moment.

MOVING FORWARD

House is about to buy out a friend's septic pumping business. This move will gain him new customers in his territory, eliminate some competition and add a new truck and contracts for about \$100,000 in work annually. Though he's only 36, it's House's way of building the business in preparation for succession.

His 14-year-old son, Garrett, is already firmly committed to the business. A pitcher and catcher on his high school baseball team, he voluntarily missed the all-star championship games to help his father. The younger House runs excavating equipment and helps in the office, sometimes riding along on pumping routes.

Dad has lots of advice for his son. "If you're getting into the sanitation business, you need to educate yourself," he says. "Get your permits, and gather all your information together so you're legal. Then start pricing trucks, the foundation of your business. If you can't afford a new one, start with one you build yourself, and work up."

But it's the example Shawn House sets for his son — more than his words of advice — that the youngster will remember.

When excessive rains swelled the Mississippi last spring, House donated six portable restrooms to sandbaggers near Hannibal, including servicing. "They didn't call, but I'd worked at St. Genevieve in the

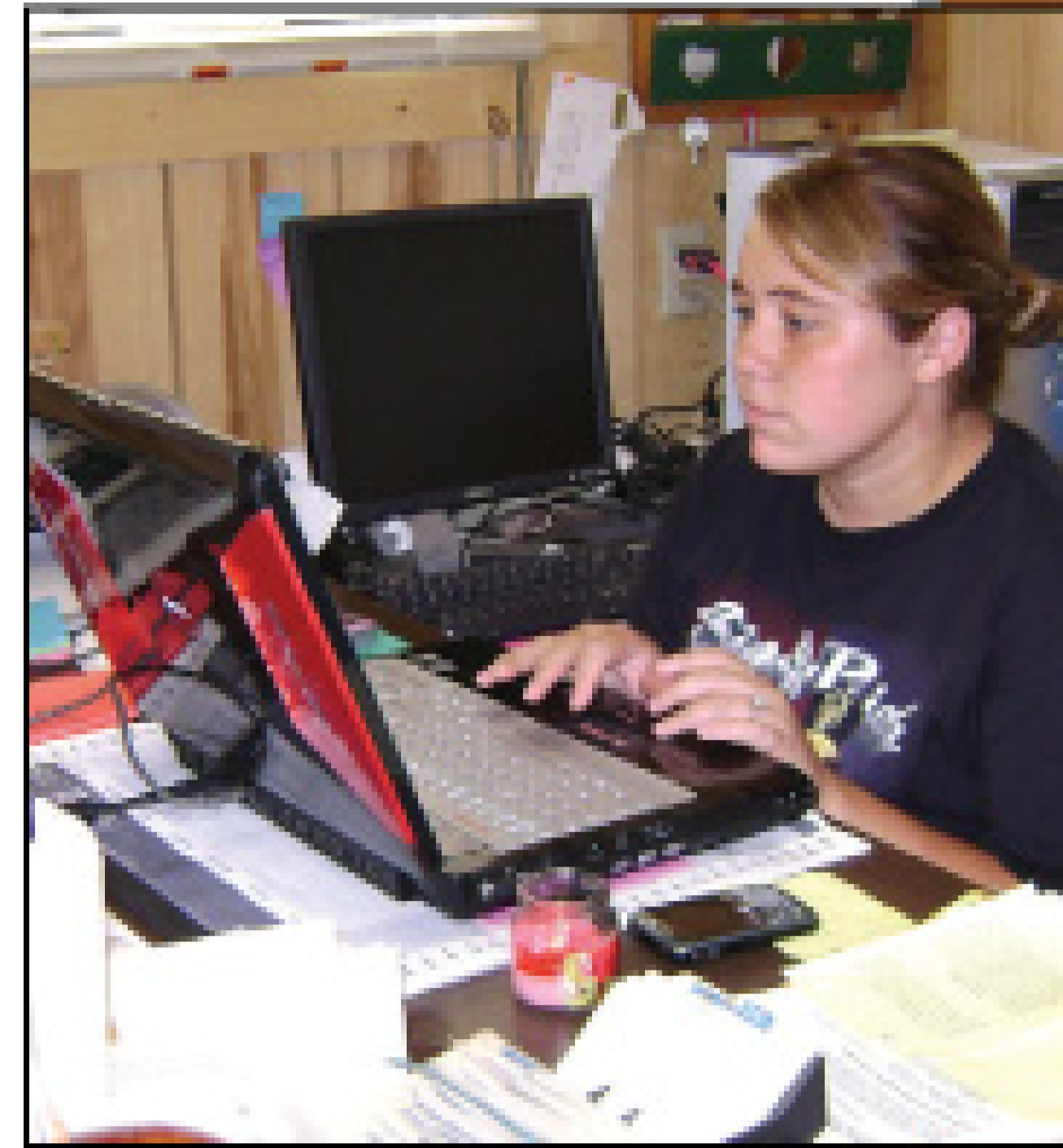

Savanna Amonds

Productivity and Safety Promote Profitability

Shawn House understands the management side of his business as well as the technical aspects. The owner of All Star Septic Tank Pumping, Boone Terre, Mo., believes in providing up-to-date tools for his office to run smoothly and effectively, keeping trucks on the road and maximizing billable hours.

Office manager Savanna Amonds has a laptop computer she can use in the office or at home, allowing House to be flexible with her hours and allow her to telecommute when necessary. She uses Quicken software to track billing and general ledger functions.

House is in the process of putting laptops in all his trucks, which will allow them to set up the software for dispatching, as well. The vehicles will then use MapQuest GPS to plot service routes for top efficiency.

Low-tech efforts are just as important in boosting productivity. When they're already on location, All Star technicians note on the job ticket any particulars about that property, such as how much hose it takes for a longer stretch on a winter job, or an odd tank location. "That helps me schedule for better weather to make a job more accessible, and that helps schedule service reminders," House says.

Productivity at All Star never supersedes the need for safety, however. House trains drivers in basic awareness issues, and the importance of wearing personal protection equipment. House says he tells his technicians, "Before you ever get in the driveway, get out and look around. Notice where you're going to go, whether you need to use longer hoses, and make sure the homeowner signs the ticket saying it's OK to back into the yard." Otherwise, they don't leave that driveway. I also stress safety around those powerful pumps."

1993 flood, so we knew they'd need them," says House. "We just

brought them up." It's the kind of quiet mentorship that stays with a young person ... not a bad legacy for a small family business and the customers who will continue to benefit from it. ■

MORE INFO:

Better Built Ind.
541/471-3680
www.betterbuiltind.com

Indiana Vacuum Tank Truck
888/777-2228
www.vacuumtrucks.com

Masport Inc.
800/228-4510
www.masportpump.com

PolyPortables Inc.
800/241-7951
www.polyportables.com

Satellite Industries Inc.
800/883-1123
www.satelliteindustries.com



Steve Skiles uses a Case Super L 580 backhoe to install 300 feet of drainfield. Below: Skiles places the cover on a newly installed septic tank. All Star offers optional risers on tanks.



TankTec

Tank Technologies & Supply Co. LLC
 Portable Restroom Service Trucks
 Septic, Grease & Grit Trucks
 Refined Fuel Trucks

888.428.6422

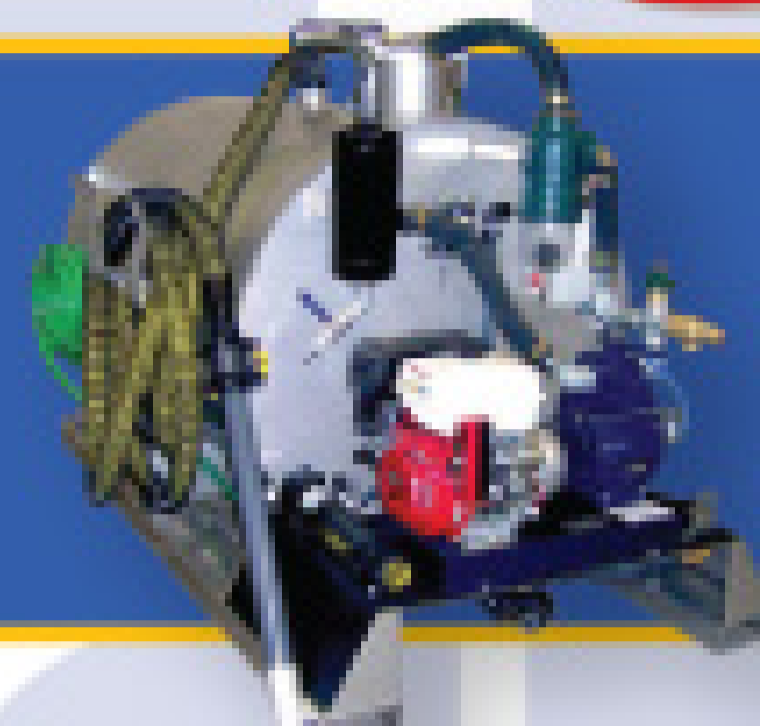

Slide-In Tanks

300 Gallon (200/100 split)
 450 Gallon (300/150 split)
 550 Gallon (380/170 split)

Aluminum Construction
 Honda Gas Motor (5.5 hp or 9 hp)
 Conde 70 CFM or Masport 106 CFM Pump
 Whale Water Pump

Completely self contained and ready to work!

2007 Chevy 7500
 2000 Gallon
\$72,000

Auto • Hydraulic Brakes
 200 HP Duramax Diesel
 Masport HXL4V 156 CFM Pump



2004 Kenworth T300
 2500 Gallon
\$66,500

Refurbished Chassis, NEW Tank and Equipment
 6-Speed • Cummins ISC 240 HP • Air Ride
 Masport HXL15V 350CFM Pump
 Aluminum Front Wheels • Chrome Bumper
 Toolbox • 156,000 Miles • 2-year Chassis Warranty



**Pumper Show
 Specials!**

FREE Dual Side Service on Portable Toilet Trucks!*
FREE Toolbox on Septic Trucks!**

* passenger side inlet, with 25' hose, valve and wand, hose hangers on tank. ** large size box, ordered to fit available space on truck.

2008 International 4400
 3600 Gallon
\$107,000 +FET

10-Speed
 DT466 300 HP/ 860 TQ
 Masport HXL400WV 400 CFM
 Water Cooled Pump System



Ask About In Stock Trucks • Call for Lease Payment Details
 Tanks in Stock • Financing and Leasing Options Available • Dual-Use Options
 Customize to Your Needs • PRS 800-2500 Gallon • Vacuum 1000-6000 Gallon

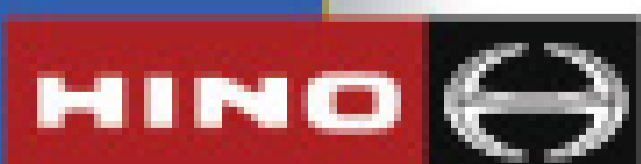

Tank Technologies & Supply Co. LLC • 888.428.6422 • www.tanktec.biz

Steve Nelson • snelson@tanktec.biz
 Andy Nelson • anelson@tanktec.biz

Local • 763.755.8075 • Fax • 763.757.9788
 10100 Quinn St. NW, Minneapolis, MN 55433

GUZZLER

Subsidiary of Federal Signal Corporation

WELCOMES BACK THE PREDATOR[®] LVT



Guzzler products have always been **EASY** - Easy to Operate, Easy to Maintain and Easy to Own. Now Guzzler makes one stop shopping **EASY**. With the reintroduction of the Guzzler Predator LVT (Liquid Vacuum Tanker), you have a full line of industrial vacuum trucks available from a single, reliable source - complete with parts, service, training and all of the expertise you have come to expect from Guzzler.....it's an **EASY** choice.

For more information about the Guzzler Predator call 1-800-627-3171 or visit www.guzzler.com

ABERNETHY

WELDING & REPAIR INC.

Call Bill Abernethy at **1.800.545.0324**

Fax: 828.324.2401 • E-mail: abernethyinc@charterinternet.com

authorized distributor for:

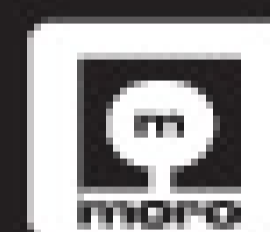

NVE



2009 Peterbilt, auto trans, 26000 GVW, AC, 1500 gallon portable service unit, HXL75V Masport pump. **IMMEDIATE DELIVERY!**



2009 International 4400E Series, 260 hp diesel DT 466 engine, 6-spd. trans. and world class auto, air brakes, 33,000 GVW, air conditioned, 2500 gal. tank, Masport HXL400 pump. **IMMEDIATE DELIVERY!**
Also, 2500 and 3500 gal. tanks **READY FOR IMMEDIATE DELIVERY.**

• **Ford • GM • International**

2009 INTERNATIONAL 4400

2500 gal. tank, (1) 6-spd. trans. & (1) auto trans.

2-2009 KENWORTH T300

2500 gal. tank, auto trans., 260 hp

NEW PORTABLE TOILET UNITS:

2008 5500 CHEVROLET

1000 gal. 700 waste / 300 fresh, 2 Wheel Drive & 4 Wheel Drive available

3-2009 INTERNATIONAL 4300

1500 gal. portable toilet service units, auto trans.

2009 KENWORTH

1500 gal. portable toilet service unit, auto trans.

2-2008 PETERBILT

1500 gal. portable toilet service unit, auto trans.

WE WILL CUSTOM BUILD YOUR TANK UP TO 5000 GALLONS!

600-1500 Gallon Portable Toilet Trucks: Our Truck or Yours

COMPLETE PARTS AND IN-HOUSE SERVICE

Cook Compression Vanes • Moro • Battioni • Jurop • Masport • Fruitland • NVE • Powerflo • Plus many other brands

OVERNIGHT DELIVERY ON PARTS • SAME DAY SHIPMENT ON PUMPS

SEVERAL GOOD, OLDER TRUCKS TO CHOOSE FROM:

- 2006 International - 2500 gal. tank, 65,000 miles, excellent condition
- 1998 Volvo - 4000 gal. tank
- 1997 Volvo - 3500 gal. tank
- 1995 Chevrolet - 1800 gal. tank, gas, under CDL
- 1995 International - 2500 gal. tank

PORTABLE TOILET UNITS:

- 2007 Chevrolet 5500 - 2-wheel drive. Call for prices. Ready to go!
- 2007 Chevrolet 5500 - 4-wheel drive. Call for prices. Ready to go!
- 1999 International 4700 - 1100/400 gal. tank, good condition
- 1999 Sterling - 1500 gal.
- 1997 Ford F450 - 800 gal. tank
- 1994 UD - 1200 gal. tank

MANY OTHER UNITS IN STOCK!

CALL FOR UPDATE

Check with us on financing for the purchase of a new truck!

WE SPECIALIZE IN PORTABLE SANITATION AND SEPTIC PUMPING EQUIPMENT

www.abernethywelding.com

POWERFLO

PRODUCTS INC.

flo

1-800-758-4788

THE POWERFLO PF 540 IS NOT ONLY OUTPERFORMING THE COMPETITION, IT'S...

...BUILT TO LAST!

**Performer Series
PF540**

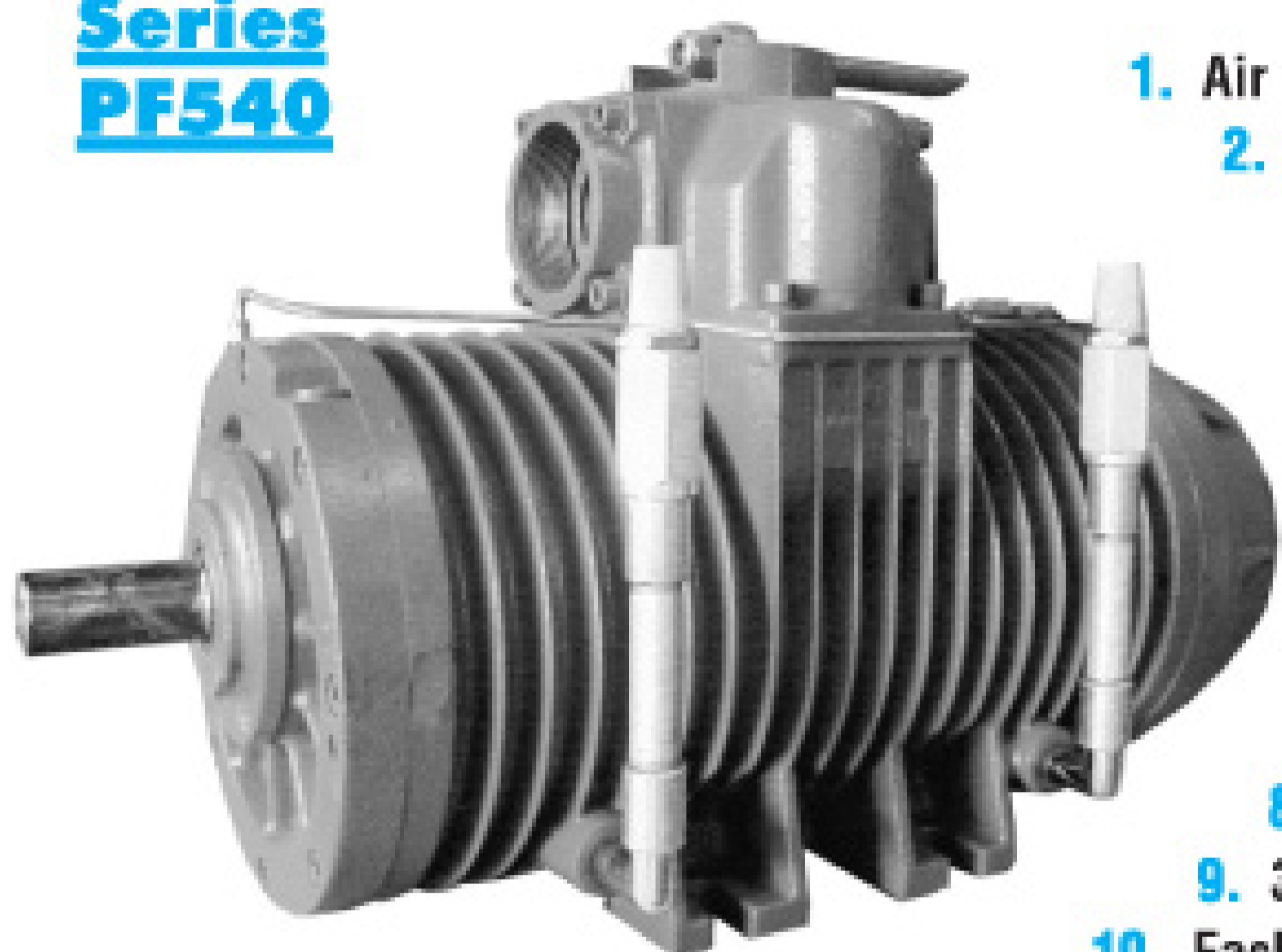

1. Air injection cooling keeps pump housing cool from within
2. The PF 540 pump utilizes five kevlar rotor vanes
3. 1.5" diameter output shaft is integral with the rotor - **No special pulleys or bolted on shafts**
4. Auto-lube system meters lube oil by way of a positive displacement gear pump
5. Heavy Duty roller bearing on output shaft end to accommodate radial loads
6. Heavy duty ball bearing on oil tank end for thrust loads
7. Extra thick end plates
8. Reinforced mounting feet and steel rod for changeover valve handle - cast iron handles can and do break
9. 3" NPT hose connections accept steel hose barbs - no aluminum connections
10. Each and every Powerflo pump is factory tested and carries a one year warranty.

POWERFLO MODEL:	PF540
Air capacity displacement	330 cfm
Air capacity displacement @ 15" Hg	310 cfm
Maximum vacuum	95%
Maximum pressure	30 psi
RPM	1200
Weight	357 lbs

Jurop
PORDENONE



R260

- 304 cfm @ 18"
- Balast Port Cooling

LC420

- 425 cfm @ 18"
- Liquid Cooled

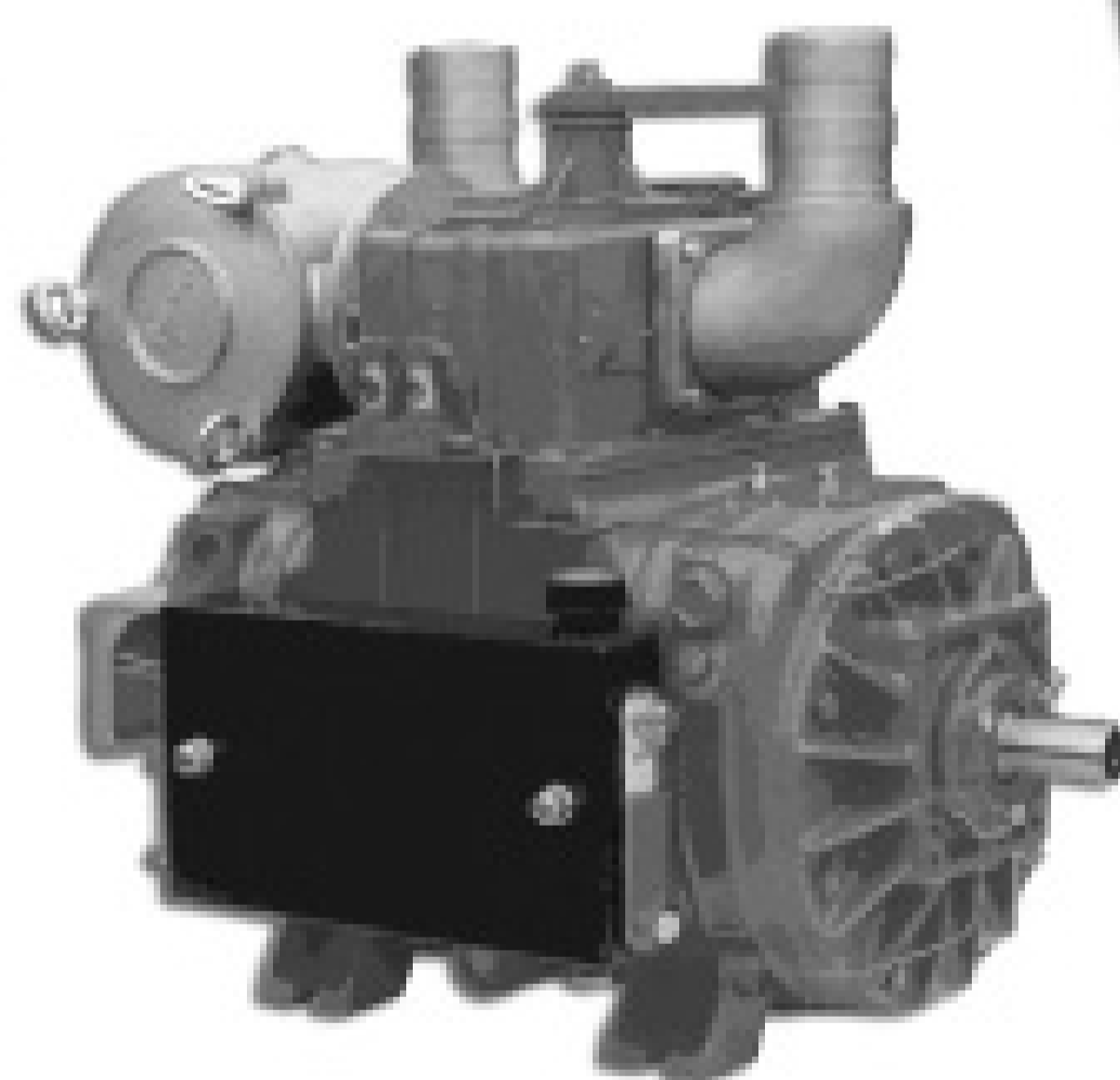

PN58

- 252 cfm @ 18"
- Air Cooled

PN 23, 33,
58, 84, 106
IN STOCK.

**WASTEWATER PUMP
PACKAGES AVAILABLE**

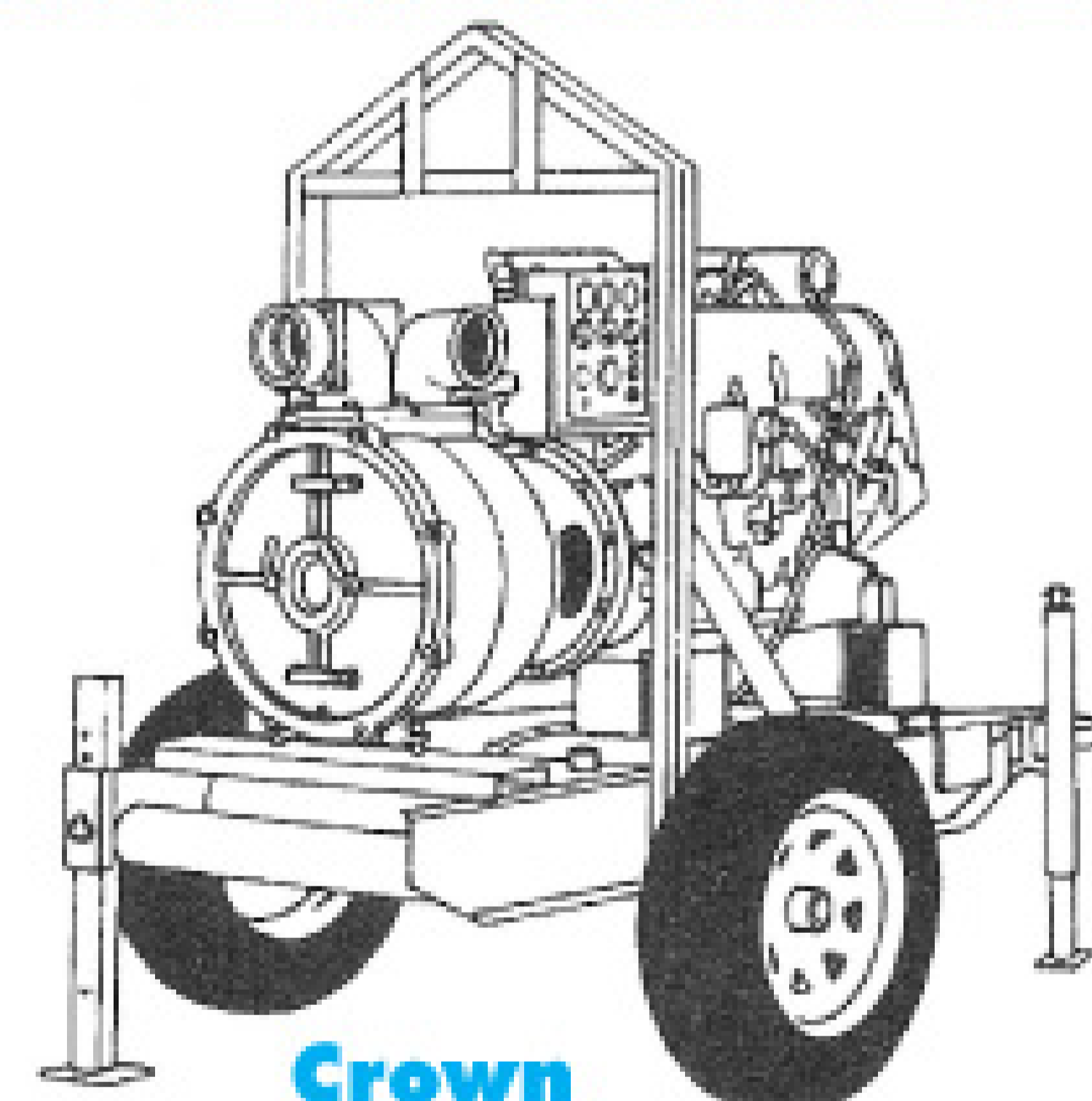

Crown

Model: CT4LC-10-F3L

PUMP VANES

**BULLET-PROOF
your pump with
KEVLAR BLADES**



DURA FLO BLADES



DC-10

Genuine Burks/Leeson Unit

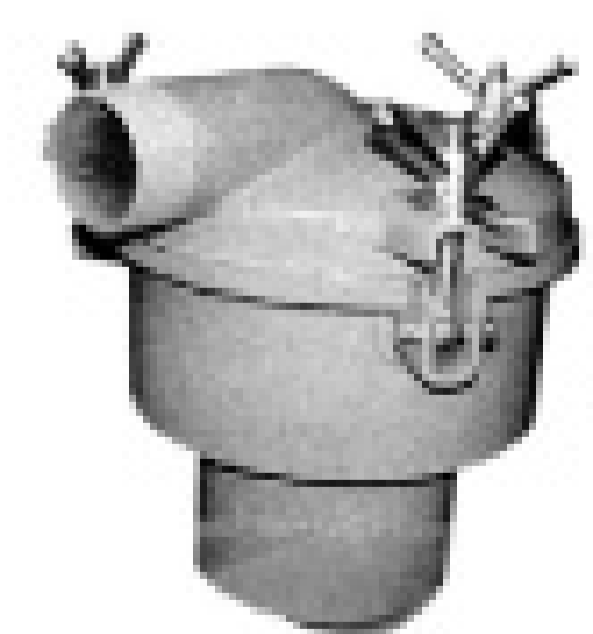

**Low Pro
Primary**
\$295

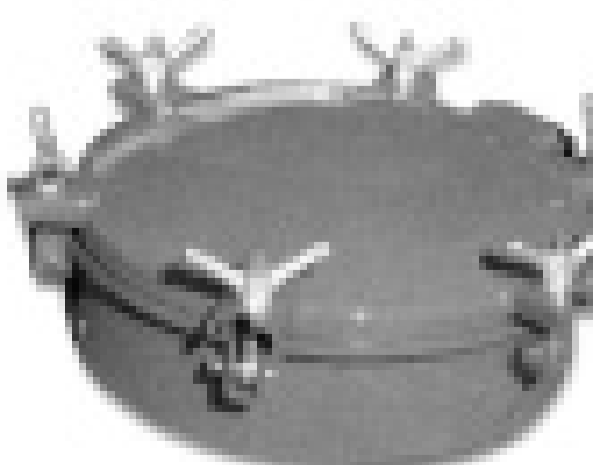

**Manway
Special
Gasket in lid**
17"
20"

**Lever Action
Gate Valve**

Brass
3" - \$98
4" - \$157
6" - \$288

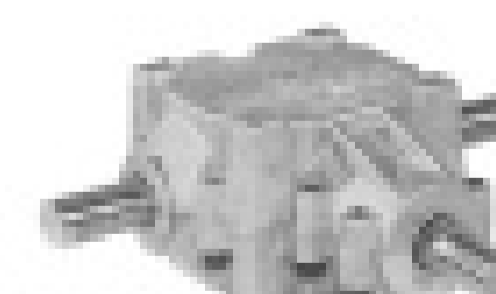

**RT Angle
Gearbox**
1"
1 1/4"

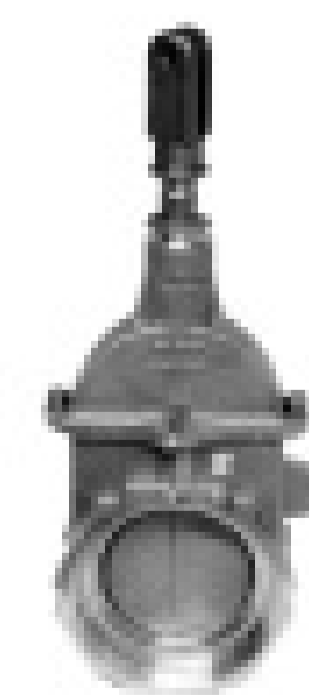

**Piston
Action
Gate Valve**

Brass
4" - \$69
6" - \$183



Pumper Dave Neelis is ready to drop the puck on his Waupaca, Wis., hockey rink (inset). The background photo shows his rink during cleanup after a recent snowfall. (Photos courtesy of Dave Neelis)



Playing **HOOKEY** Means Playing **HOCKEY**

When the pumping business slows in the dead of the Wisconsin winter, Dave Neelis trades his vacuum hose for skates and drops the puck on his personal ice rink

Unlike many of his peers, Dave Neelis, 36, did not play hockey as a kid growing up on the frozen tundra of Central Wisconsin.

But Neelis, owner of Dave's Sewer Service, Waupaca, Wis., is making up for lost time.

"I got into hockey 11 years ago and I love it," he says. "We have a men's league in Waupaca and I sponsor and play for the Dave's Sewer Service team."

Neelis also got his daughters involved in youth hockey when they were 9 and 10 years old, plus he built and maintains a full-size hockey rink in his rural front yard, where he spends hours skating and working on his game.

"You can't beat playing hockey outdoors like it was when it started back in the day," he says.

Neelis got started in hockey when a buddy who owed him money said he would pay him back by paying his fee to join a local amateur hockey team.

"I didn't even know how to skate very well," he recalls. "But it was the only way to collect my money."

Already active in sports like volleyball, softball, tennis and snowmobiling, Neelis discovered he enjoyed hockey too. But being a latecomer to the game, he felt he needed more practice.

"When my daughters started playing too, I built the rink, because we wanted to better ourselves but I couldn't afford to rent ice all the time," he says.

Neelis initially thought he'd make the rink about 20 by 20 feet — just big enough for himself and the girls to practice stick handling and shooting. When he finished, it was 60 by 150 feet with a goal on each end for pick-up games with buddies or local kids.

"This is the fifth winter I've had a rink," says Neelis, whose business office doubles as a warming shed. "Perfect ice is my goal."

Or possibly, his obsession.

IF YOU BUILD IT ...

To start the project, Neelis put his excavating skills to work, removing dirt to a four-foot

depth and piling the spoils around the outside of the rink. For the first couple of years, pucks would fly out of the rink and get lost in the dirt, which, he says, was an annoyance, so two years ago he took the next step. He built dasher boards inside the rink and leveled out the dirt embankments.

He fills the rink each year with water from a neighboring farm's irrigation pond, and yes, he cleans out his 1981 International truck with a rebuilt engine, 2,400-gallon tank and Moro M-10 pump and uses it to haul the water.

Neelis waits until the temperature gets down to 15 degrees for a few days and puts one layer of about 7,000 gallons of water in the rink for a base.

"Most of it soaks away, but if I'm lucky it will freeze enough to get it started," he says.

He'll add a second layer, and after that ice "takes" and is good and hard, he'll haul 20,000 to 30,000 more gallons of water to flood the rink.

"The pond is seven or eight miles away and by the time we get back the previous layer is hard already," he says.

After the water is hauled, the rink is filled and the ice is hard, Neelis' work has only just begun.



Dave and Tina Neelis pose with their daughters, Elizabeth and Samantha, on a family vacation during a warmer time of the year.

“Last year was the worst year for ice. There was no frost, so we dug septic tanks all year round.”

Dave Neelis

“We have a well and there’s a hydrant by the rink so I can hose down the ice after anyone finishes skating on it,” he says. “A lot of times I’m out here until midnight or even 2 a.m. because that’s when it’s coldest, so it’s the best time to hose it down. It gets rock hard.”

Neelis says a good winter for his business is a bad year for ice, so he’s covered whatever Mother Nature brings.



If you’re going to make a regulation-sized hockey rink in your back yard, it’s nice to own a fleet of vacuum trucks. Neelis utilized a service vehicle to fill the rink with water taken from a neighbor’s pond.

“Last year was the worst year for ice,” he says. “There was no frost, so we dug septic tanks all year round.”

In a good ice year, Neelis will fill the rink in December and skate through mid to late February. “After that, the sun beats on it too much,” he says.

Neelis took over Dave’s Sewer Service from his dad, who still occasionally helps out his son and the company’s two employees. They pump 70 to 80 tanks a week in the busier non-ice seasons. Over the years the company has accumulated a variety of trucks, including a 1992 Ford L-8000 with a 2,300-gallon tank and a Moro M10 pump; a 1989 International with a 3,500-gallon tank and a new Jurop R260 pump; plus a 1996 International being outfitted with a 2,300-gallon T-Line tank and a Moro M10 pump.

SNOW PROBLEM

Building an ice rink involves a lot of experimentation. Neelis says a plastic liner would be ideal, but is cost prohibitive. For the first few years, the rink bottom was sand, but this year he tried a different approach.

“I waited until it snowed, got my four-wheeler and snowmobile out and kept driving over and over it until it was packed down,” he explains. “Then at about 9 p.m. I watered it down with my garden hose. The next morning I had ice, and then I started hauling water.”

Neelis says it’s the best ice he’s had yet.

“I dumped about 24,000 gallons but didn’t lose any water into the ground, so I have thicker ice this year,” he says. “I have anywhere from 4 to 9 inches depending on my low and high spots.”

Frequent Wisconsin snowfalls create an ice maintenance issue. For light dustings, Neelis skates around with a shovel. He says it takes him about 90 minutes to clear the entire surface this way. For heavier snows, he uses a snow blower or a skid-steer to remove the snow from the ice. He’d really like to have a Zamboni ice-surfacing machine, and is trying to figure out how to convert a riding lawn mower into a small-scale resurfer.

Neelis’ daughters Elizabeth, 16, and Samantha, 15, continue to skate on the rink frequently, even though their involvement in organized team hockey has decreased as they progress through their teen years. Neelis’ wife, Tina, also uses the rink, though Neelis says she’s not always its biggest fan.

“Tina wasn’t very happy at first since I used an acre to build the rink and I spend so much time on it,” he says. “But then she started to skate with us and it was all good.” ■

After Hours is an occasional feature that describes how business owners reconcile work life with family, leisure time, charitable pursuits, and personal interests and passions. Pumper welcomes story ideas. If you take part in something interesting outside work, or if you know someone in the pumping business who does, please send a note to editor@pumper.com.

NEED IT? RENT IT!



Air Machines
Liquid Vacs
Liquid Rings
Roll-Offs
130 Bbls
Cyclones
Combos

YOU MIGHT AS WELL RENT THE BEST.

NEED IT? RENT IT!

1-888-955-2087

Mississippi • Louisiana • Texas • South Carolina

www.vactruckrental.com





CIRCLE D TRUCK SALES

www.circledtrucksales.com



IN STOCK

2003 MACK CH613, E7-427HP, Fuller 15 speed, odo shows 511K miles, 46,000lb RA, 14,000lb FA, double frame, 3:90 ratio, 11R42.5 tires, (2) 145 gl. aluminum fuel tanks, chrome exhaust, tilt/telescopic wheel, cruise, AM/FM stereo, AC, PS, 20 ton pintle hitch, new white paint. "NEW" 2008 Bulldog vacuum tanks, 3,360 gallons (80 bbl), 1/4" head & shell thickness, primary & secondary shutoff, (2) top man ways, (1) rear clean out, (2) internal baffles, sump with (2) 4" rear outlets with wafer style butterfly valves, front sight glass, vacuum & pressure relief valves, full length hose trays, rear bumper, Jurup R260 vacuum /pressure pump with pump stand and right angle drive. new white paint. FET included in price. VERY NICE TRUCK!!! Stk. #2363 **\$85,500**



VERY NICE!

2006 MACK CV713 GRANITE, 105,500 on miles per odo/odm, AMI 370 HP, engine brake, new black paint, "NEW" Triplex high pressure pump consists of: TEE Triplex Pump, 3" plungers, 5" stroke, hardened steel valves with block steel fluid end for well service, 4.68:1 gearbox, pneumatic plunger oiler system, charge pump: 4" x 3" centrifugal pump, mechanical drive, load pump: 4" roper pump, mechanical drive, low pressure manifold consists of: 4" schedule 40 SA-106 seamless pipe and fittings, 4" butterfly valves, high pressure manifold consists of: 2" 1502 discharge pipe with 1502 Long Sweep Swivel and 1502 union, 10,000 lb. check valve, 10,000 lb. bleed off valve, 10,000 lb. relief valve, cab mounted control panel, triplex pump shifter, Centrifugal Pump Shifter, Flow Rate Meter Display, Lube Oil Pressure Gauge, Plunger Oil Pressure Gauge, Work Light Switches, Headache Rack with Work Lights, New Black paint to match Truck. New 70bbl. Vacuum tank and jurup R260 vacuum/pressure pump. CALL FOR COMPLETE SPECS ON THIS TRUCK! Stk. #2290 **\$278,000**



IN STOCK

2006 FREIGHTLINER FLD120SD, 186K miles (actual miles), MBE 350 HP, Allison 4500 RDS, 40,000 lb RA, 12,000 lb FA, air ride suspension, engine brake, 4:63 ratio, 202" WB, 127" CT, dual 80 gl. aluminum fuel tanks, cruise, AC, PS, AM/FM stereo, chrome exhaust, "NEW" Presvac DOT-MC MC 412, 3150 gallon, tilt with full open rear head, 4" load line with riser, 6" discharge, catwalk with handrails, fruitland RCF 500 vacuum pump. Includes FET; VERY NICE!!! Stk. #2287 **\$149,500**



VERY NICE!

2008 TROXELL 1308BL. Vacuum trailer, non-code, 4 spring suspension, steel composition, 24.5 tires, all steel wheels, tandem axle, steel composition, 5460 gallons, 1 compartments, full length walkway with tool box, (2) 4" butterfly valves, scrubbers, full length hose trays. Ready to haul!! \$1500 for optional belly line. Stk. #1906. **Call For Price.**



READY TO HAUL

2006 FORD F-650 SUPER DUTY, Ext. cab, ODO shows 38,864 miles, 230HP Cummins, Allison automatic, 26,000 GVW, 4:33 ratio, spring suspension, aluminum wheels, 265/70R/19.5 tires, 65 gl. fuel tank, chrome bumper, power windows, power locks, tilt, Cruise, AC, PS, AM/FM CD, hydraulic brakes, electric brake control, NEW: HD Dutac mechanics bed with tool trays, xxy/act cabinet, bumper with receiver hitch, new 3200 lb Liftmoore crane and control box, new Miller Bobcat welder/generator, new Champion air compressor with 21 CFM and 30 gl. tank, new white paint on bed. Very Nice Truck!!! Stk. #2394 **\$72,500**

MORE TRUCKS AND TRAILERS AVAILABLE, IF WE DON'T HAVE IT WE'LL FIND IT!

Lee Dill, John Trammell, Gary Chandler
CIRCLE D. TRUCK SALES

4502 E. OVERLAND TRAIL • ABILENE, TX • 79601
325-677-0474 • FAX: 325-677-0686

888-433-0474

1000 Gallon Trailer Mounted Vacuum System



EXPERTS IN PORTABLE VACUUM SYSTEMS!

PACS 1000

PACS trailer mounted vacuum systems are available in a variety of configurations. PACS 1000 is designed for removing liquids, solids, and sludge from land or water. Costing less than vacuum trucks, the PACS is approved for highway towing. Integral hydraulics allow the PACS to run oil skimmers and pumps, as well as lift the tank to dump contents.

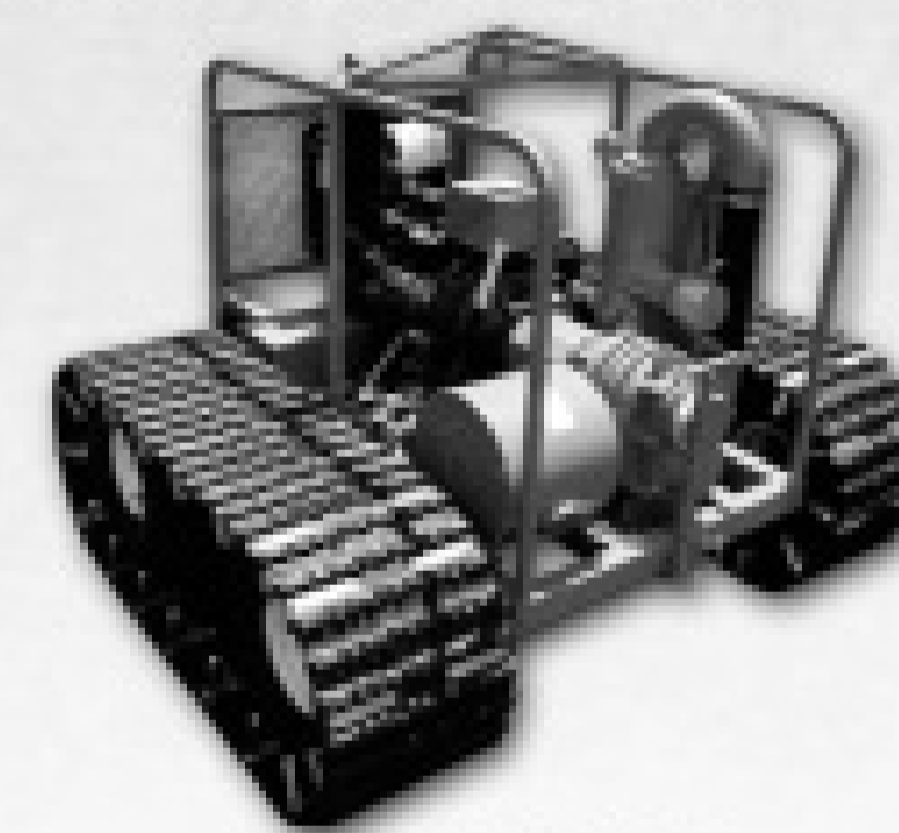

ELASTEC
All Terrain Vac

Oil Skimmer

Sucking up money for vacuum trucks

Our Drum Skimmers are optimal for rapid response oil cleanup. Extremely efficient and cost effective, they will give you an edge over competitors.



DrumIt

The drum filling vacuum head with auto shut off. DrumIt quickly connects to vacuum trucks for a clean interception of debris and liquids.



ELASTEC
AmericanMarine
Innovative Environmental Products

1309 West Main, Carmi IL 62821 USA
Tel: (618) 382-2525
Fax: (618) 382-3610
E-mail: elastec@elastec.com

www.elastec.com

PU10/08

SAVE TIME, MONEY,... AND YOUR REPUTATION!

GAMAJET®

- **Hands-Free Cleaning**
- **Eliminates Odors**
- **No Splash Back**
- **Cleans Entire Unit**
- **Satisfaction Guaranteed**

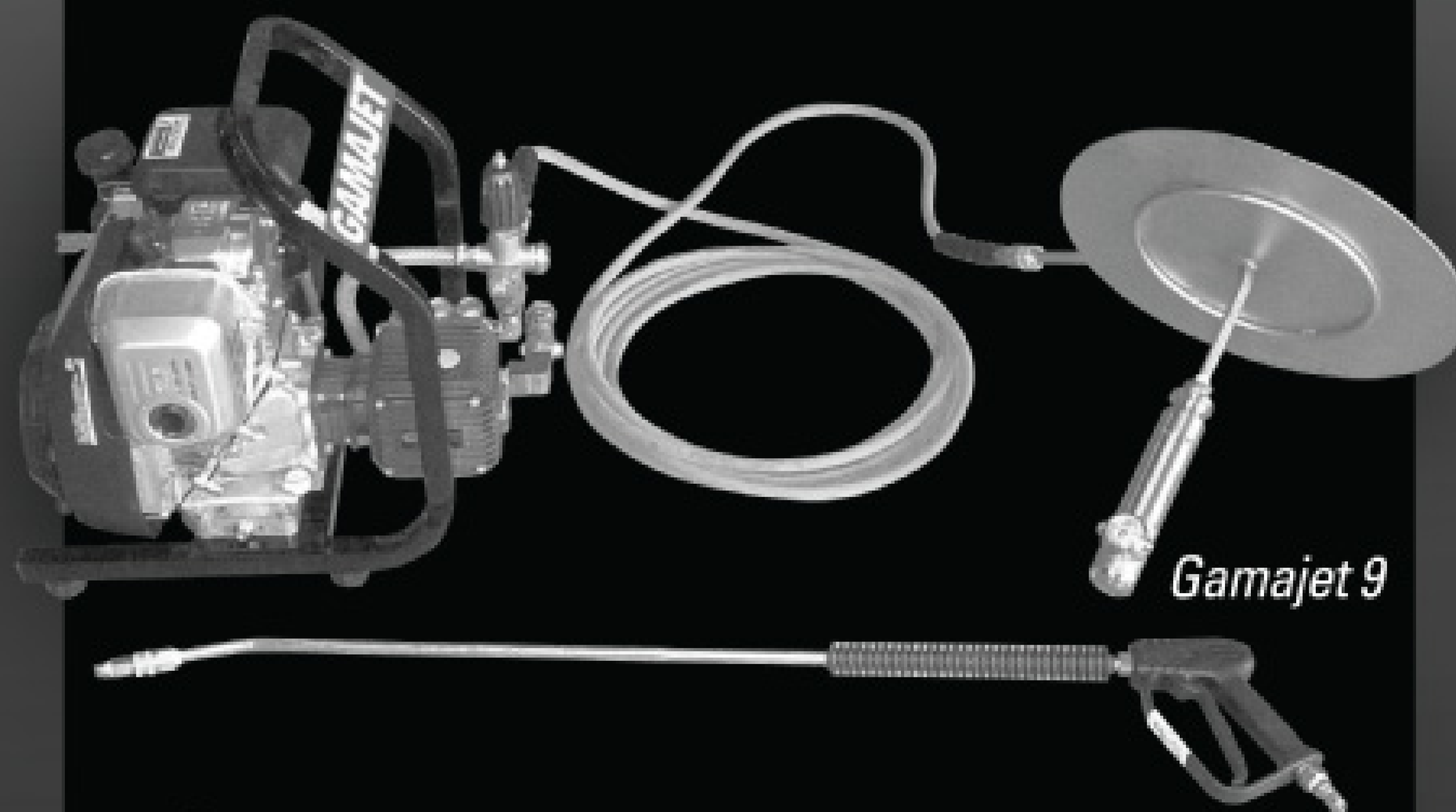

GAMAJET®

Cleaning Systems, Inc., 604 Jeffers Circle, Exton, PA 19341
Gamajet.com • email: sales@gamajet.com

1-877-GAMAJET

WORLDWIDE EXPORTERS

27th TRUCKS INC.

8975 N.W. 27TH AVE. • MIAMI, FL 33147 • PH: 305.835.9030 • EMAIL: INFO@27TH-TRUCKS.COM

2 Year
Factory Warranty
on Pumps



2001 MACK
3600 Gallon Tank, \$59,000

10 Year Factory Warranty
on Aluminum Tanks



1999 PETERBILT
3600 Gallon Tank

IN PRODUCTION

- 2005 Mack 4000 Gallons, Dumping
- 2003 Mack 3600 Gallons (\$65,000)
- 2005 Mack 4000 Gallons
- 1999 Mack 3600 Gallons (\$49,000)
- 1999 Mack 2500 Gallons (\$39,000)

5 year Factory Warranty
on Carbon Steel Tanks



1999 PETERBILT
3600 Gallon Steel Tank



2005 MACK VISION
4000 Gallon Steel Tank, \$75,000.

WWW.27TH-TRUCKS.NET

Contact Alan @ 305-457-8058, Armando @ 786-267-3026, David @ 786-236-9007



Aqua-Zyme Disposal Systems

"From the Grease Trap to the Garden"
- Dewatering & Composting -

#1 Box on the market!

The ADS Dewatering System

is built by a pumping company for pumpers. You are welcome to come and watch the 30 yard box dewater 20,000 gallons of grease trap waste and/or septic tank waste in only 2 hours!

By using the ADS dewatering system along with our Compost Facility, we have turned our disposal costs into a profitable venture!

Call 979-245-5656 for Info!
\$ Financing Available \$

P.O. Box 489, Van Vleck, TX 77482 • www.aqua-zyme.com
1-979-245-5656 • zymme@aqua-zyme.com • U.S. Patent # 6,364,122



Filter Box Interior

Draining Down



Thank you for visiting
us in Louisville

Experience the raw power of...

SURCO®

BLUE • MUSCLE™

THE MOST POWERFUL PORTABLE TOILET DEODORANT IN THE INDUSTRY

Stock up and Order Today!

1-800-556-0111

or on the web at:

www.surcopt.com

SURCO®

– Since 1946 –

292 Alpha Drive • Pittsburgh PA 15238

1-800-556-0111 412-252-7000

www.surcopt.com



©2008 SP



KNOW-HOW TO GET YOU MOVING

Now In **STOCK!** On-The-Lot Selection *Call For Prices & Pre-Approval!*



2007 Sterling 4400 aluminum tank, NVE 506 pump, PTO jetter 10 GPM, 3500 PSI 150 gallon water tanks 66000 GVW, 410 HP, 10 spd.

Call for price



2007 Sterling 2500 gallon Steel Jurop pump, Mercedes 260 HP, 10 spd, engine brake, traction control ALUMINUM HOSE TRAYS.

Call for price

WHO OFFERS MORE?

- Great Low Prices on Quality Equipment
- FREE Delivery in the Lower 48 States on New Sterlings
- 5 Year Engine Warranty on new Sterlings (Mileage allowances vary by model)
- Delayed Payment Start (to approved credit)



New 2009 Tandems in stock for fast delivery

Call for details

Badger's New Sterling Trucks include a **5 year Engine Warranty** coverage

We Have Financing Available!

Call Us Today Toll-Free:
888-201-9166

www.badgertruck.com

Septic - Portable Toilet - Hoisted Vacuum - Slide-Ins
New! Units Available / Trade-ins Accepted! / Financing & Lease Plans



Flagg-Air Model 340

- 3450 rpm
- 1/4 hp, 115V
- Enclosed motor
- Stainless steel shaft
- High impact plastic parts
- Operates quietly
- 2-yr. warranty
- Fits in place of most original manufacturers' units
- Replacement parts available



The Flagg-Air 340 does not carry the NSF seal. Check local and state regulations for approval in your area.

MEDO HEM LA-80 Linear Pump



with low pressure alarm & light; with on & off switch

MEDO Piston



LA-60
LA-80B
LA-100
LA-120

SECOH Diaphragm



EL 60
EL 80
EL 100
EL 120



0523
1023

Rotary Vane Compressor

Regenair®

R3105-12 Blower

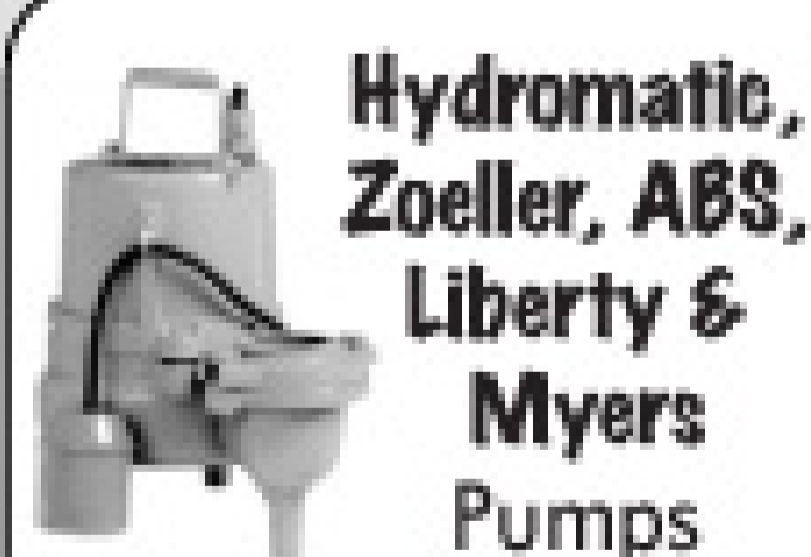
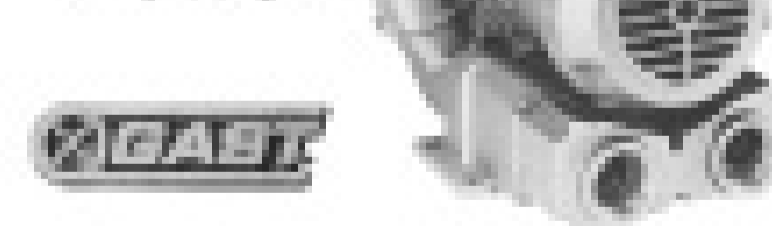

Hydromatic, Zoeller, ABS, Liberty & Myers Pumps

Conde SDS 6 Engine Driven



Units available 20 to 180 cfm



Moro PM80 Turbo 350 cfm

Moro Pumps: from 175 to 1642 cfm

LIBERTY PUMPS



Hope you enjoyed the show. Thanks for visiting us!

We Carry a Full Line of

LIBERTY PUMPS

and Pre-Assembled Lift Station Packages



Omnivore LSG 200 Residential Grinder



280-Series Mid-Range Effluent Pump



BIO Control Panel

with Lift Station, Aerator, Timer & High Water Alarm

Myers High Head Filtered Effluent Pump



Septic Services, Inc.

toll free 1.800.536.5564 • 636.583.5564 • fax 636.583.6432
e-mail septic@fidnet.com • web www.septicserv.com





TOUGH DAY AT WORK?

The one and only Supersucker® makes the job easier.

- Industry's simplest operation sequence - single control panel set-up that even the newest employees can quickly learn
- Fast, simple unloading procedure makes debris removal easy
- Low maintenance design including one-step filter cleaning system
- High-power vacuum with superior air flow performance
- Heavy-duty, durable construction for long lasting life and use in the most extreme conditions

For more information or to request a FREE demo that shows why the original Supersucker is still the industry's best vacuum loader, visit www.theoriginalsupersucker.com or call **Super Products** today at 800.837.9711



Easy to Operate; Easy to Clean; and Easy to Maintain.



As part of your spring maintenance routine, check tread depth on each tire in your fleet. (File photo)

It's
Time
to

KICK THE TIRES

Tim Miller has been a tire design engineer and technical representative for Goodyear. He is currently marketing communications manager for the tire manufacturer, and can be reached at timothy.miller@goodyear.com.

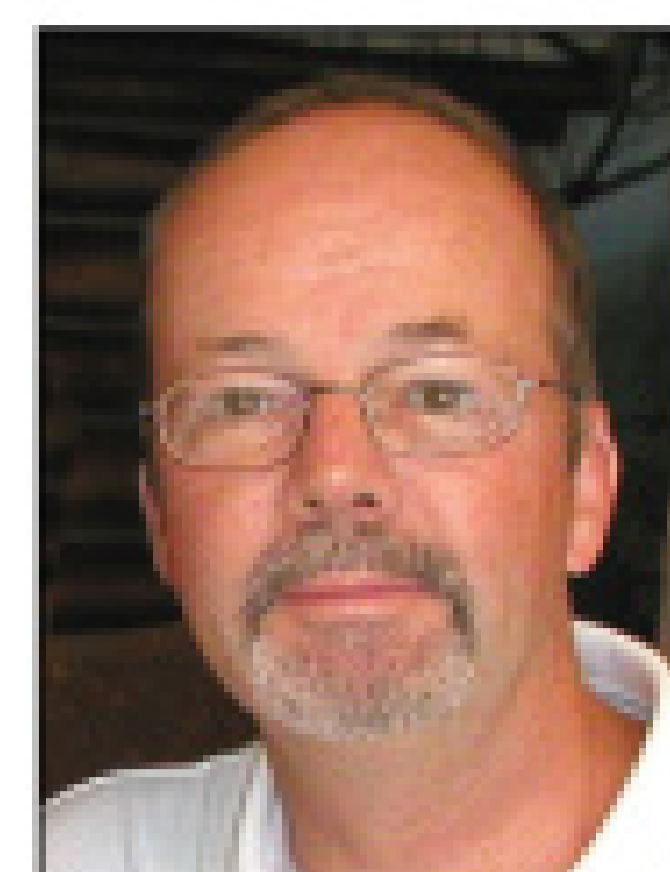

As you gear up for another busy season, make sure your service fleet has plenty of rubber to meet the road

By Tim Miller

Spring is coming, and it's a good time to get out in the yard and perform a tire quality inventory on your fleet of vacuum trucks and other service vehicles. Today's tires can take an enormous amount of abuse, but neglecting them can be quite costly. Follow these 10 basic tire maintenance procedures to lower your per-mile tire costs through extended tread life and fewer premature removals:

1 Determine proper inflation levels for your application. The biggest influence on tire life is inflation pressure. At normal speeds, running tires at 20 percent under recommended pressure reduces tire mileage by 16 percent and fuel mileage by 2 percent. To determine the correct air pressure for your tires, gather information on your actual axle loads and refer to tire load charts provided by a tire manufacturer.

2 Establish a good inflation maintenance program. Tire pressure is difficult to maintain because tires naturally lose air over time. Use a calibrated air gauge to check air pressure at least once a week. Flow-through valve caps make it easier for operators to check pressure and add air without removing the valve cap. Note that changes in ambient temperature will affect tire pressures. For every 10-degree F decrease in temperature, the pressure will drop 2 psi. So, during the colder months of the year, operators need to check and inflate tires more often.

Urban routes present many opportunities for potential sidewall damage. Alert drivers to the importance of avoiding sidewall impacts and suggest driving maneuvers to reduce sidewall contact. Encourage drivers to inspect tires regularly for sidewall wear and damage.

3 Keep vehicles properly aligned. Poor vehicle alignment causes most irregular tire wear. For example, steer axle toe-out will cause excessive wear on the inside of both tires while toe-in will cause wear on the outside shoulders of the tires. Ideally, most steer tires should have a small amount of toe-in. To maintain this, as well as stay on top of other types of irregular wear, your vehicles should be aligned regularly. If you've never had a periodic alignment program in place, you can increase tire mileage by as much as 30 percent by implementing one.

4 Mount tires correctly. The rounder or more concentric the tire, the better it will wear. To keep tire run-out to a minimum, tires should always be mounted on the wheel correctly. Ideally, the tires should be match-mounted to the wheel. Check with the tire manufacturer to see how they mark their tires. The idea is to take the high spot of the tire and match it to the low spot of the wheel. If you mount properly, you may not need to balance the tire/wheel assembly.

5 Learn to "read" tires. Drivers typically don't check tread wear unless they experience ride problems. By then, it's often too late to prevent premature wear. Regular tire inspections provide a lot of useful information and catch wear trends before they do too much damage. Problems can be diagnosed by visual inspection or by running a hand over the tread and feeling for abnormalities. Items to check for include distortion in the tread, feathering or cupping. If corrected early, bad wear patterns can be countered to extend tire life. Since rib-edge feathering is an early indicator of misalignment, your truck should go in for an alignment at the first sign. While feeling the tread, inspect the entire tire for safety-related damage such as cuts, cracks, blisters or bulges. If the damage is severe, the tire should be removed.

6 Rotate tires. Moving tires around takes time and effort. The temptation is to leave them in one position for the life of the tread. But intelligent tire rotation promotes even tread wear and can net a lot of extra miles in tread life. Drive tires should be rotated

between forward and back positions at least once to even out wear. Rear tires of a tandem typically will wear quicker than the forward positions. Some drive tires will also develop heel and toe wear. This can be evened out by reversing their direction.

7 Protect sidewalls from curb damage. Urban routes present many opportunities for potential sidewall damage. Alert drivers to the importance of avoiding sidewall impacts and suggest driving maneuvers to reduce sidewall contact. Encourage drivers to inspect tires regularly for sidewall wear and damage.

8 Replace tires with matching ones. For optimum tread wear, tires should be as alike as possible across the same positions. If a tire must be pulled due to irregular wear or a road hazard, it should be replaced with a tire matching the existing one. The more you can do to eliminate variation, the better your tread wear will be. On dual assemblies, the outside diameters and tread depths should be as close as possible. A good rule of thumb is no more than 2/32-inch tread depth difference between duals. It's also wise to have the same tread design on both positions of an axle.

9 Check and replace worn wheel and suspension components. These can be the hidden enemies of tire life. A wheel bearing that is not properly torqued can cause irregular tire wear. Worn shock absorbers can create depression wear on treads. To prevent irregular tire wear, replace shock absorbers and other suspension components on a set schedule.

10 Keep good tire records and use the data wisely. Because every contractor's operation is different, copying another contractor's practices may do more harm than good. To manage most efficiently, collect and record information including tire inflation pressures, wear trends, and tire mileage at removal. Analyze tire performance over time and compare with different vehicle configurations and tire types. By changing specifications, you may be able to realize significant gains in total tire mileage and other performance goals. ■

What's Your Opinion?



Pumper welcomes letters from readers responding to articles we publish or offering comments and opinions of interest to the industry. You can submit your letter by:

MAIL: Pumper, P.O. Box 220, Three Lakes, WI 54562
FAX: 715/546-3786 ■ E-MAIL: editor@pumper.com

All letters must be signed. Please limit your letter to 500 words or less. We reserve the right to edit all letters for length and clarity.



"Duel Power Lid"

Plugs, Lids & Adaptor Rings

Sizes Available: 18", 24", 30" & 36"



Fergus Power Products
 Providing "Environmental Products"

The Company who maintains a pulse on the environment!

Toll Free **1-800-243-7584**
 E-mail **fpproducts@prtcl.com**
www.FergusPowerProducts.com

INTRODUCING...

After Shock

Bioremediation

Restorative

The Next Generation in Soil Absorption Area Restoration:

SAME DAY BIOREMEDIATION SERVICE!

Cape Cod Biochemical Company, the premier provider of natural septic system solutions since 1976, proudly introduces the culmination of intensive, dedicated laboratory research....

AfterShock Soil Absorption Restorative

AfterShock is a unique blend of laboratory-enhanced, naturally-occurring, primarily aerobic organisms that are type-specific to the various substances that typically clog drain fields and leaching structures. **AfterShock** also contains a proprietary, bacteria-friendly, time-release oxidizing agent that will accelerate the bacterial action of the organisms in the product to restore drainage in most soil absorption areas.

Unlike all other oxidizing products, **AfterShock's** consortium of bacteria and oxidizer can be applied **at the same time**. The oxygen-accelerated bacterial action will quickly digest the solid material that reduces the drain field's capacity to absorb water, effectively restoring drainage through a natural process. The bacteria contained in **AfterShock** are authorized by the USDA, and have been treating septic systems around the world since 1976.

To learn more about this revolutionary approach to restoring drainage, as well as our entire line of products for residential and commercial septic system treatment, grease waste systems, and for bioremediation, please call us toll-free at 1-800-759-2257 to request our product information package. Or log on to www.septiconline.com. There is no cost or obligation, and no obnoxious salesman will call you (a big plus with us).

If you've waited to get involved with bioremediation because the process is so tedious and time-consuming, now is the time to get involved. Do it all in ONE TREATMENT. Please call today. Thank you.

—Rick Howe, President



GREEN PRODUCTS FOR SEPTIC PROFESSIONALS SINCE 1976

CAPE COD BIOCHEMICAL COMPANY

P.O. Box 990 • Pocasset, MA 02559



1-800-759-CCLS
 (1-800-759-2257)

FAX: 508-564-9974 • www.SepticOnline.com



“We invest in People”



Call **800-344-2224**

and ask for
Bob Marino

- **New and Used Equipment Financing**
- **Competitive Rates and Terms**
- **No Hidden Cost/Simple Application Process**

- > Portable Restrooms > Video Inspection > Jetters
- > Service Vehicles > Industrial Vac Trucks



www.CenterCapitalCorp.com

Celebrating 26 Years of Loyal Service

*Center Capital Corporation is a subsidiary of Webster Bank, N.A., Member FDIC
All financing programs are subject to credit approval.



UNIT SHIPPED TO AFRICA



STAINLESS STEEL & STEEL UNITS -
CALL FOR INFORMATION



TANKS TO YOUR SPECIFICATIONS

PUMP DISTRIBUTOR

BATTIONI JUROP
BOWIE MASPORT
FRUITLAND MORO

Pump Rebuild Kits In Stock

**CALL TODAY FOR
INFORMATION
OR PRICES ON
TANKS, PUMPS
AND ALL PARTS**

Secondary Shutoffs

Sight Glasses, Valves & Couplings



12" Primary Shutoffs

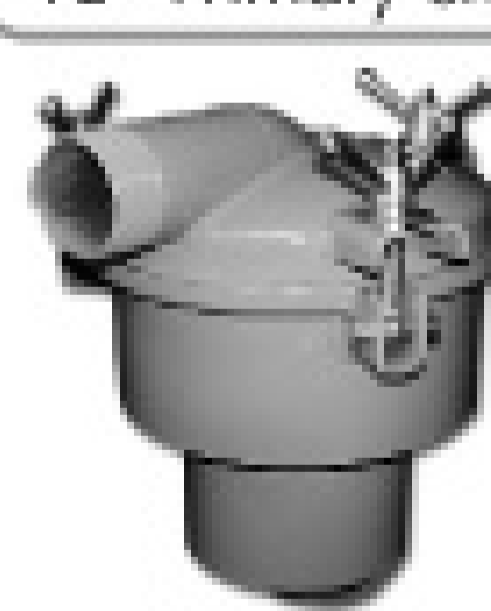

21" & 36" Manways



CUSTOM SKID UNITS



800.364.7307

2100 EAST BOOTH ST. • SEARCY, AR 72143
Fax: 501.279.0003 • E-mail: sbs@cdlworld.net

Drive A New Kenworth today for \$73,975

BEST BUY!

Buy a Kenworth for **LESS** than a Chevy or Ford.

2008 Kenworth T3 Series

Aluminum Cab - Non CDL - 22,000 G.V.W.

8,000 lb front axle -14,000 lb rear axle, Paccar (Cummins) Turbo exhaust brake, Allison auto transmission, 19" Wheels
So much more...

Power door locks, AM/FM stereo, cruise control, 160 amp alt. air suspension seat, R.H. electric window, peeper window, Stainless steel piano-style door hinges

1700 Gallon Aluminum Tank

(2) Compartment (400 water / 1300 waste)

Low style work station on drivers side, bucket holders, Masport HXL4 vacuum pump, remote controls, unit hauler Burks DC 10 wash down system with timer and bypass, spring rewind reel, large cabinets... *all the features.*

Monthly Lease From...**\$1157**



2008 Kenworth T3: **\$38,900**
Tank /Pumping System: **\$35,075**
Sale Price: **\$73,975**

F.O.B. Kansas City

2007 Chevrolet 7500

'Old Emission' 200 HP 7.8 liter Automatic trans, air brakes, AC.

2000 Gallon

1500 Waste/500 Fresh Masport HXL4, Burks DC-10 washdown, Hot Shift P.T.O w/remote. **Dual Service**

\$73,275 As Low As \$1222 mo.



2000 Gallon Septic Tank

Masport HXL75 - 230 C.F.M. vacuum pump system.

Tool Box... standard extras

2008 Hino 338

33,000 G.V.W. 260 H.P. diesel, 6 speed and air brakes. 12,000 front / 21,000 rear

\$79,900

Monthly Lease From...\$1559



3600 Gallon Septic Tank

Masport HXL400 water cooled

2008 International 4400

310 HP, 10 speed transmission

\$106,000 Plus F.E.T.

F.O.B. Kansas City

Monthly Lease From...\$1984

LaVerne Charlet

email: ictanks@bellsouth.net / fax: 270-898-4055
175 Cascade Drive, Paducah, KY 42003

L.C. TANKS

1-888-848-3727





WHEN FIVE PEAKS BECAME SATELLITE,
WHAT ELSE HAPPENED?





SYNERGY WORLD



SUDDENLY,
OPERATORS BEGAN
TO SEE THE DOOR
OF OPPORTUNITY
WIDE OPEN

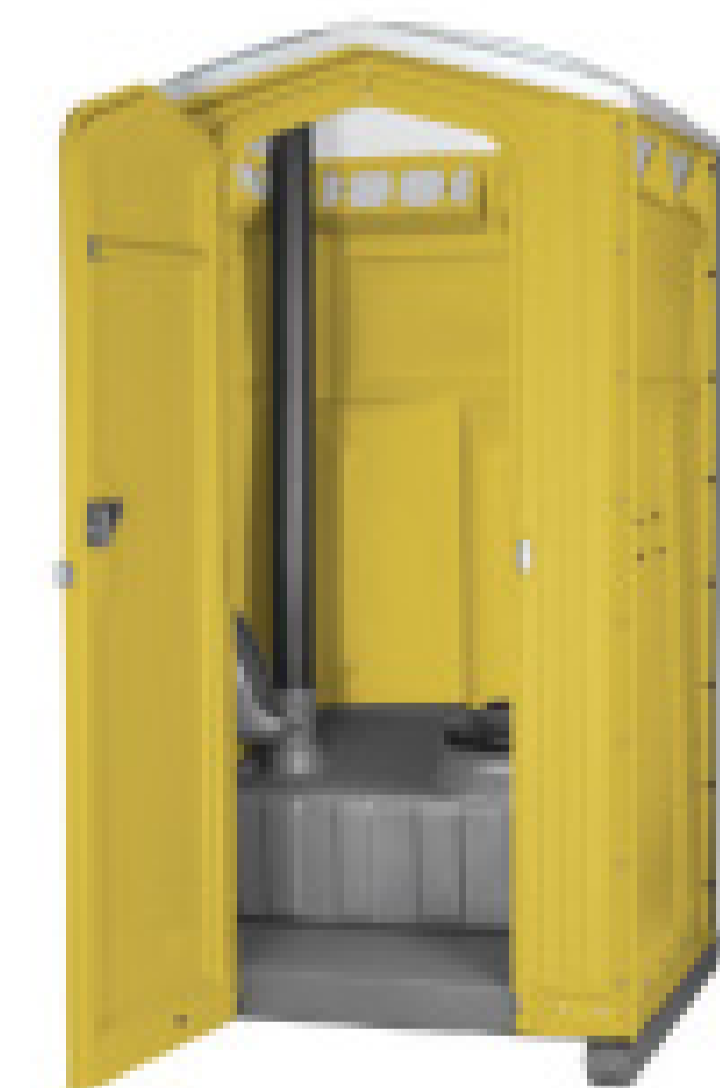
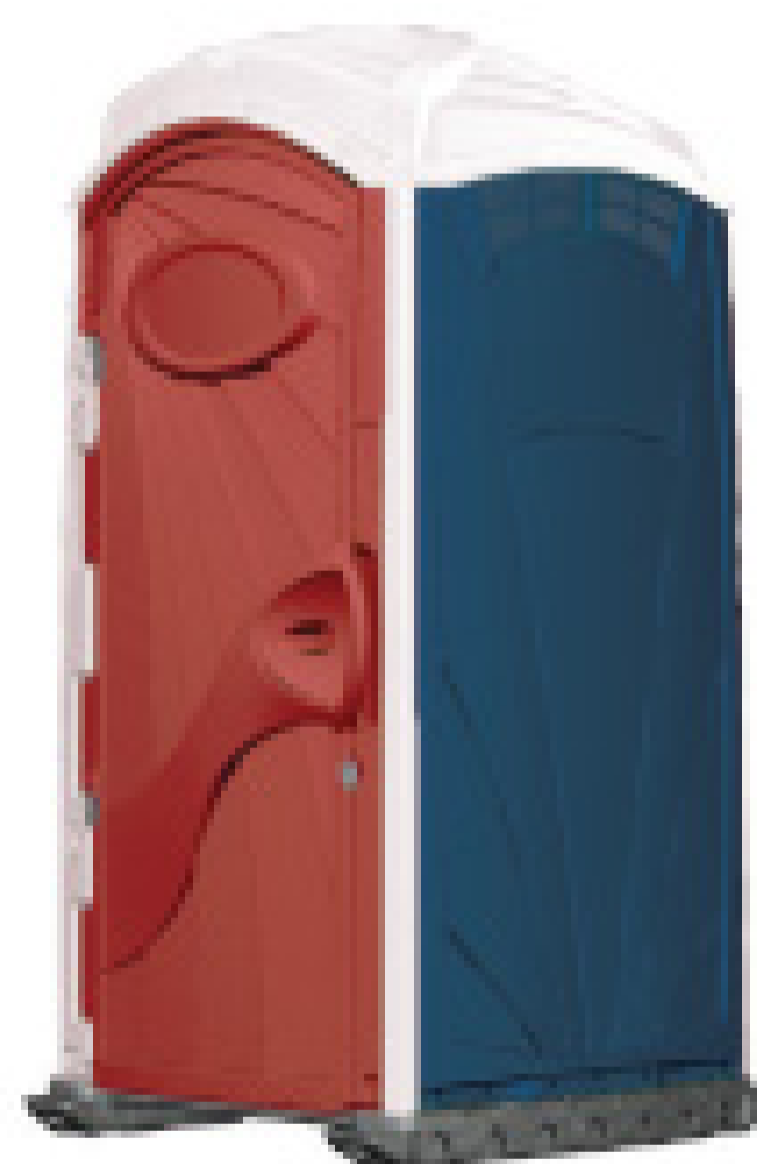

Find a style that works for you...

800-328-3332

www.satelliteindustries.com



Buy Your Competitor?

The purchase of another company in your field can be a quick way to expand, but you have to proceed with due diligence

By Erik Gunn

A challenging business climate might not put expansion on the top of your priority list, but there may be some good reasons for you to think about growing the business now ... or as the economy bounces back.

You could start the ball rolling by investing in new equipment with an eye to moving into a new territory next to the communities where you already do business. Or you could redouble your efforts to grab more market share where you already operate.

But if you're contemplating growth, there's another option: Buy out a competitor. Buying another shop in the same line as yours, whether down the street or in the next town or county over, can be a quick way to enlarge your operations, and your bottom line. To be sure, there are pitfalls — some financial, others in the tricky area of emotions.

They don't have to stop you, though, as long as you're careful. Like any major decision, buying a competitor can entail risk. But it also can pay off handsomely.

WHOM TO BUY

One obvious prospective target business is one in which the owner is getting ready to retire and looking to cash out. That kind of deal is likely to be low-key and comfortable for both parties.

Don't expect to pay a fire-sale price, though. If there's no real urgency, your seller will hold out for the best offer he or she can get. After all, the proceeds from the deal may be funding a retirement, or perhaps a trust fund for children or grandchildren. Those will be powerful motivations to try and win a few extra dollars at the negotiating table.

Another prospect could be a struggling business. You might get a pretty good deal here, but you'll have to be careful. The operation you purchase might be having trouble because of poor practices, and if you take it over, you'll need to restore its reputation.

The quickest solution then will be to let the older business brand disappear and replace it with your own, assuming you've built a strong reputation over the years. But you should probably consider building into your cost calculations what it will take to launch an advertising campaign that helps your new operation stand apart from the poorly run one you're taking over.

Sometimes good matches can be made between a pair of thriving companies. In that case, you're not so much buying out a competitor as potentially getting "married" to him or her. If the competing owner plans to stay on, you'll need to take time getting to know that person to make sure the two of you are compatible.

WHEN TO BUY

The time to buy is closely tied to whom you're going to buy, of course. If your competitor is retiring, the answer of when is elementary. If failing, the same. Beyond that, the decision of when will depend on other factors: Can you get financing? Is the price good (perhaps because

Erik Gunn operates Great Lakes Editorial Services, consulting for businesses, non-profits, and individuals. Readers may direct inquiries to him by contacting this publication at 800/257-7222 or e-mailing editor@pumper.com.



Sometimes good matches can be made between a pair of thriving companies. In that case, you're not so much buying out a competitor as potentially getting "married" to him or her. If the competing owner plans to stay on, you'll need to take time getting to know that person to make sure the two of you are compatible.

of tough economic times)? And are you ready to take on the new responsibility of a bigger business? Every deal is different, but in essence there are three ways to buy a company.

Just buy the customer list. That's the cheapest route, and if that's all your seller has to offer, it probably means the business itself is on its last legs anyway.

Buy the assets — equipment and customers. Again, that's much cheaper than buying the business itself, and for that reason, the owner may be very interested in those terms. Look at it this way: If you sold your house, which way would you get more? Selling a working, intact home? Or tearing out the floorboards, shingles, wiring, carpet and fixtures and auctioning them off individually?

Buy the entire business. This is the most common way to buy a business. It's especially good for you as the buyer if you can find ways to capitalize on the firm's great reputation and goodwill. But this approach also means evaluating the purchase with extra care. Are there debts that will become yours? Any lawsuits you're buying your way into? Other liabilities you're taking over? Will you have to honor existing labor contracts?

WHAT STANDS IN THE WAY

Potential obstacles to a buyout include the reputation of the firm you're buying, the sort of liabilities it has, and whether you will have a business relationship with the seller after the deal is finished.

Financing is another hurdle. If you're buying a healthy business with good cash flow and a robust bottom line, you may be able to use its future profits to help finance the deal. But credit markets have become much more cautious. Be prepared to answer tough questions before your banker writes you a loan.

GET PROFESSIONAL HELP

Of course, any deal as big as buying another business shouldn't go without close scrutiny by a team of advisors: an accountant, a lawyer, and a business valuation expert. Yes, these services will add to the total transaction cost, but the money is well spent if it helps you make a deal that will work in the long run or helps you avoid a major mistake.

There's no one way to grow your business, and perhaps you're more suited to an incremental approach that expands bit by bit on your strengths. But if you find an opportunity to expand by buying out a competitor, take a good look. It might just be the door to new challenges — and new accomplishments. ■

WHAT'S THE DIFFERENCE BETWEEN A BULLET AND A SLUG?



DriPax, THROW AND GO DEODORIZER. IT'S ALL ACTION!

Those bullets streaking down the highway can be your trucks when you use new DriPax throw and go deodorizer. No more messy liquids, no more awkward measurements, no half dissolved tablets and packets, no delays. Just pure deodorizing power in a 100% biodegradable portion controlled pack. DriPax is all action - no fillers. It's the difference between a bullet and a slug.

Aim to get your free samples now. Call (800) 241-7651.



99 Crafton Drive, Dahlonega, GA 30533 USA • Phone (800) 241-7951 or (706) 864-3776 • Fax (706) 864-8111 • www.polyportables.com

Only PolyPortables offers high-performance Green Way Products

TOILET DEODORIZERS • TOILET CLEANERS • AIR FRESHENERS • INSECT REPELLANT

All Green Way deodorizers, cleaners and air fresheners are earth-friendly, people-friendly products. They are developed and manufactured in our facilities in Dahlonega, Georgia by Green Way Products, a PolyPortables sister company.



CAPITAL RUBBER CORP

Get Connected.

WEATHERFLEX EPDM

THE VAC HOSE WITH AN ALL RUBBER TUBE



3" X 25 FT \$ 102.50

3" X 33 FT \$ 129.50

4" X 25 FT \$ 165.00

COUPLINGS INCLUDED!

THANK YOU FOR
VISITING US AT
THE 2009 EXPO!

THE ORIGINAL BUMBLE BEE VAC

NEW LOW PRICES



JETTER HOSE

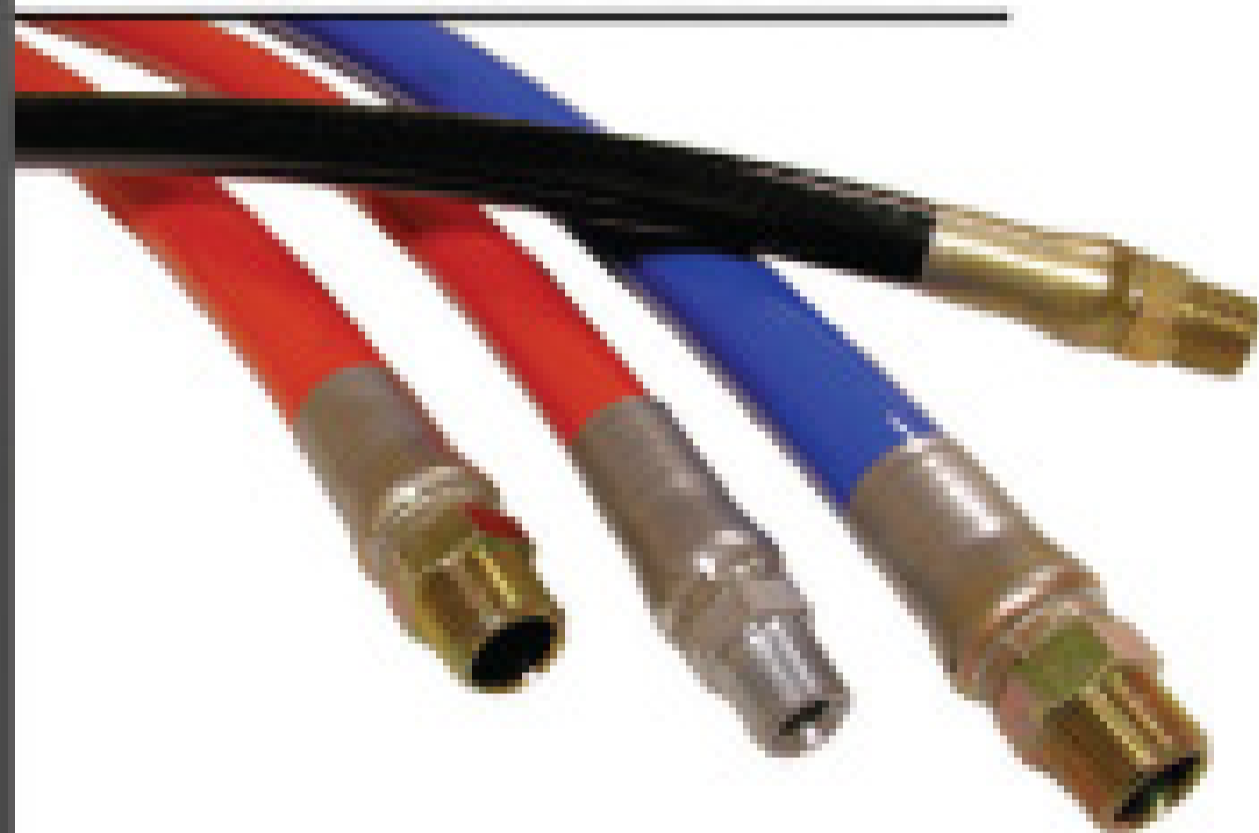

SAFETY BUMPS

HANDLE HOSE
WITH EASE!

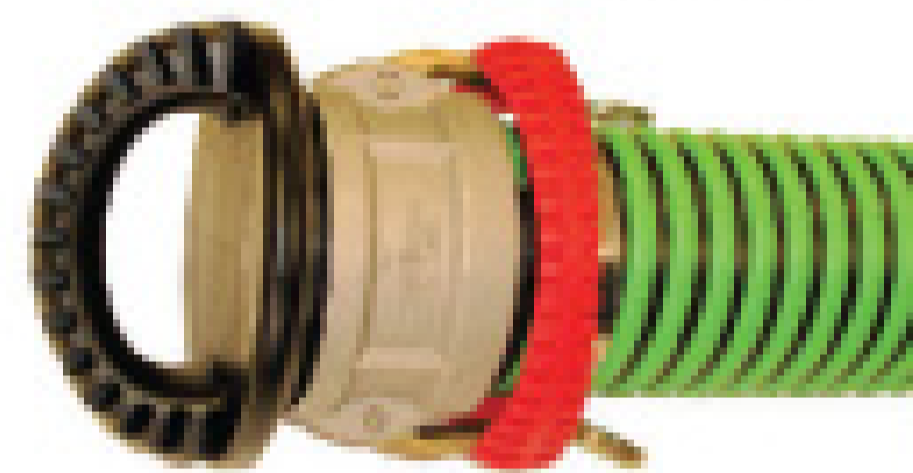

NEW LOW PRICES

POWER BOOSTER

INCREASE VERTICAL LIFT



PUMP DIFFICULT JOBS WITH EASE
LIFT HEAVY SLUDGE AND WASTE
REDUCE PUMPING TIME & LABOR
GET MORE DONE IN A DAYS WORK

The Power Boosters unique patented design allows you to harness the power of a compressed air or water source to increase the performance of your vacuum truck!

FREE 50 FT AIR HOSE

WITH POWER BOOSTER PURCHASE!

845 N DILLON DRIVE
WOOD DALE, IL 60191

(800) 258-3000

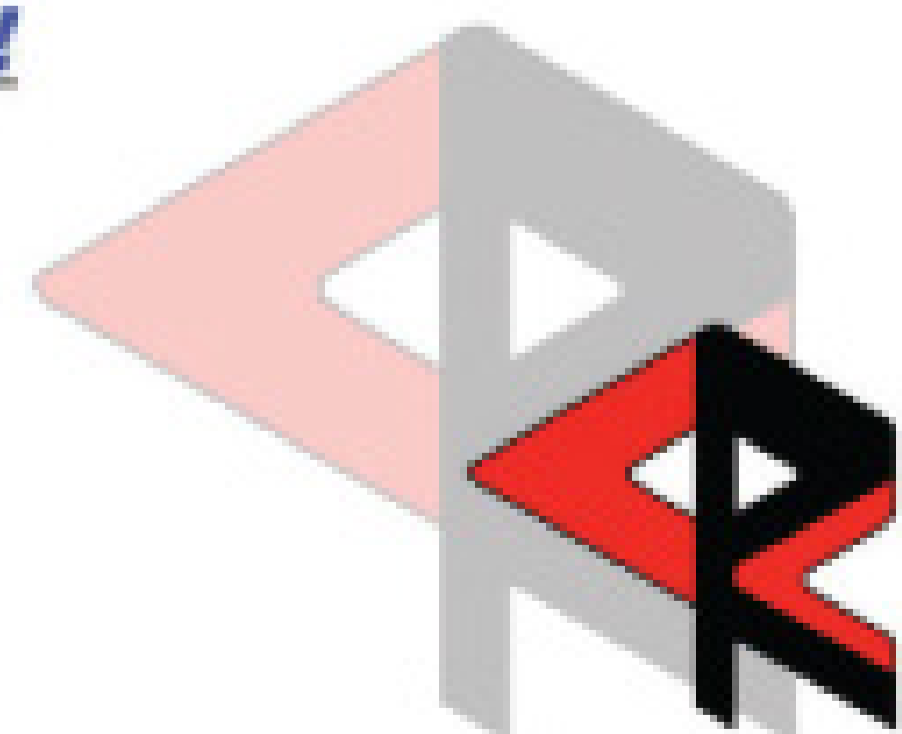

WWW.CAPITALRUBBERCORP.COM

Celebrating
70 yrs

VACUUM PUMP TECHNOLOGY
FOR THE PORTABLE, SEPTIC & GREASE PUMPING
INDUSTRIES.

Made in America

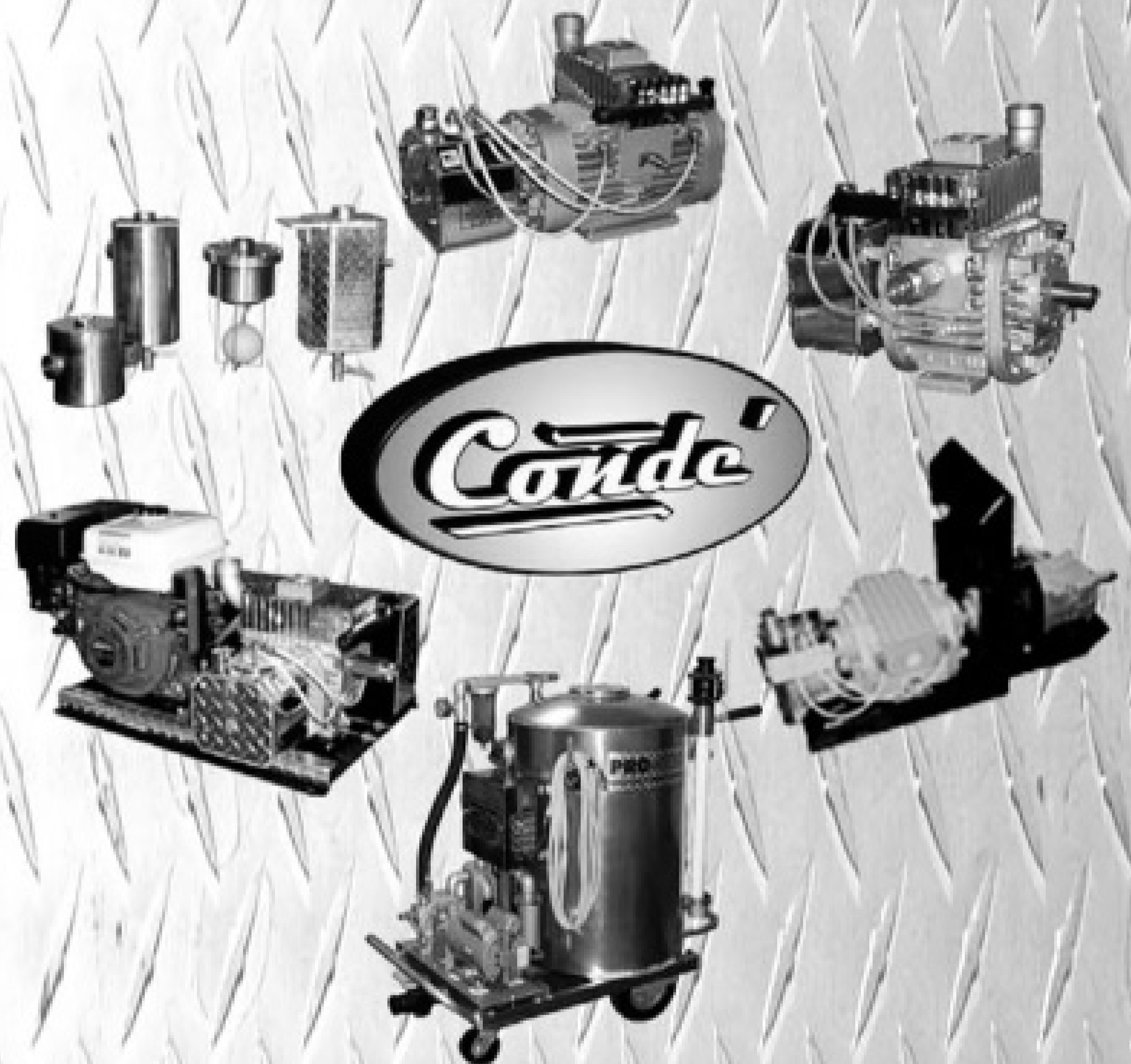

Thank you for visiting our booth in
Louisville!!

Westmoor, Ltd appreciates your business
and we look forward to serving you for
another 70 yrs!!

Westmoor, Ltd

PO Box 99, Sherrill, NY 13461

www.westmoorltd.com pumps@westmoorltd.com

800-367-0972

PORTABLE TOILET
SERVICE UNITS

SLIDE IN UNITS

HOISTED UNITS

ROLL OFF UNITS

CUSTOM UNITS



Manufacturing & Sales

60 Pik Rite Lane - Lewisburg, PA 17837

1-800-326-9763



Thank you for visiting
us in Louisville

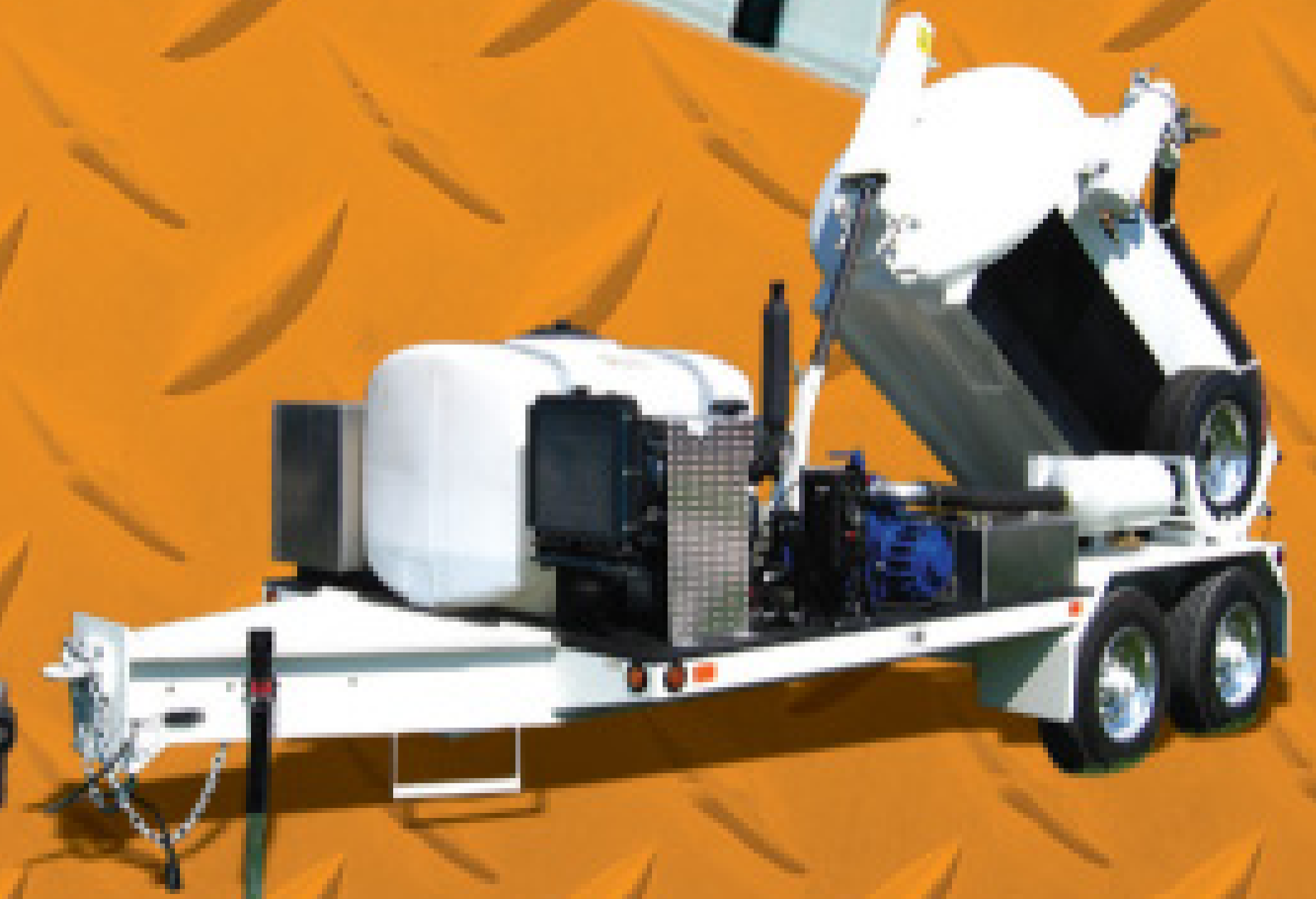

COMPLETE LINE OF PARTS IN STOCK

www.pikrite.com



wallenstein septic pumps

CALL FOR PRODUCT LITERATURE
AND
YOUR NEAREST AUTHORIZED
DISTRIBUTOR



Thanks for
visiting us!

- > Quality construction
- > Rugged design
- > Wide fiber vanes
- > Easy internal access
- > Low noise level
- > Two year warranty



220 CFM



275 CFM



350 CFM

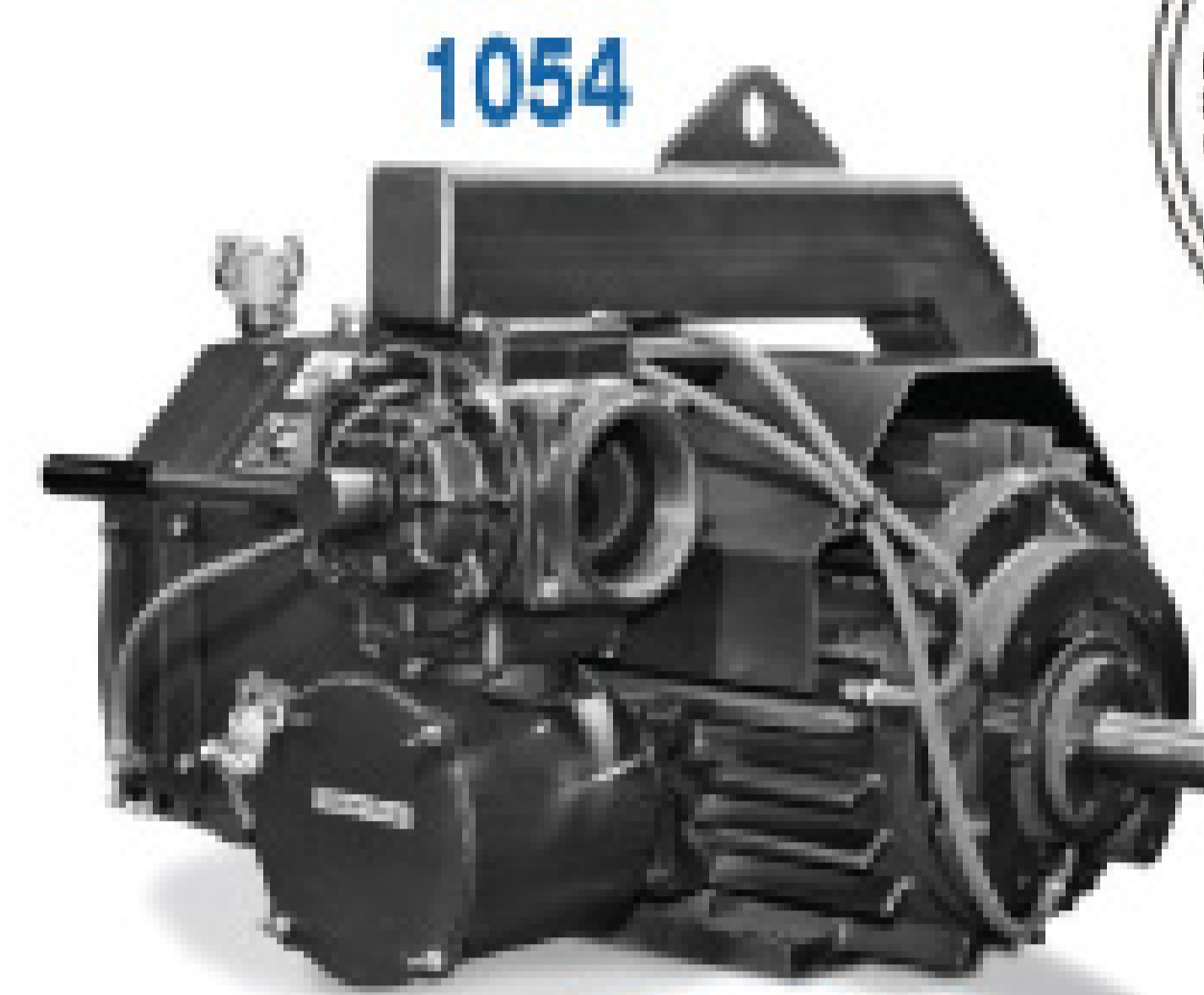

500 CFM



Series	Rating CFM	Vacuum "HG	HP 1/2 HP of Diesel Engine	Tank Size US Gallon
403	220 @ 1150	27	18	2000
553	275 @ 1150	27	24	2500
753	350 @ 1150	27	30	3500
1054	500 @ 1000	27	40	5000+

Toll Free 1-800-801-6663 fax 519-669-8331 email info@wallensteinpumps.com



**Our All Natural Products EXCEED
the Green Seal Standards to Better
Protect Our Environment**

ONE STOP SHOPPING!
Offering a Complete Line of
All Natural Portable Toilet & Septic Needs

Complete Line of Paper Products
Portable Toilet Chemicals including:
 Eliminator Nano Emulsifier Deodorizer
 Nev-R-Freeze—Portable Toilet Anti-Freeze
 All Purpose Degreaser
 Graffiti Remover
 Hand Sanitizers
 Urinal Blocks

Servicing the Industry with Pride Since 1994
250 Old Marlton Pike • Medford, New Jersey 08055
800-699-9903 • Fax: 609-714-3030 • www.delvel.com



Thanks for
visiting us!

\$ We've Got the Money \$

For All Your New and Used Equipment Needs

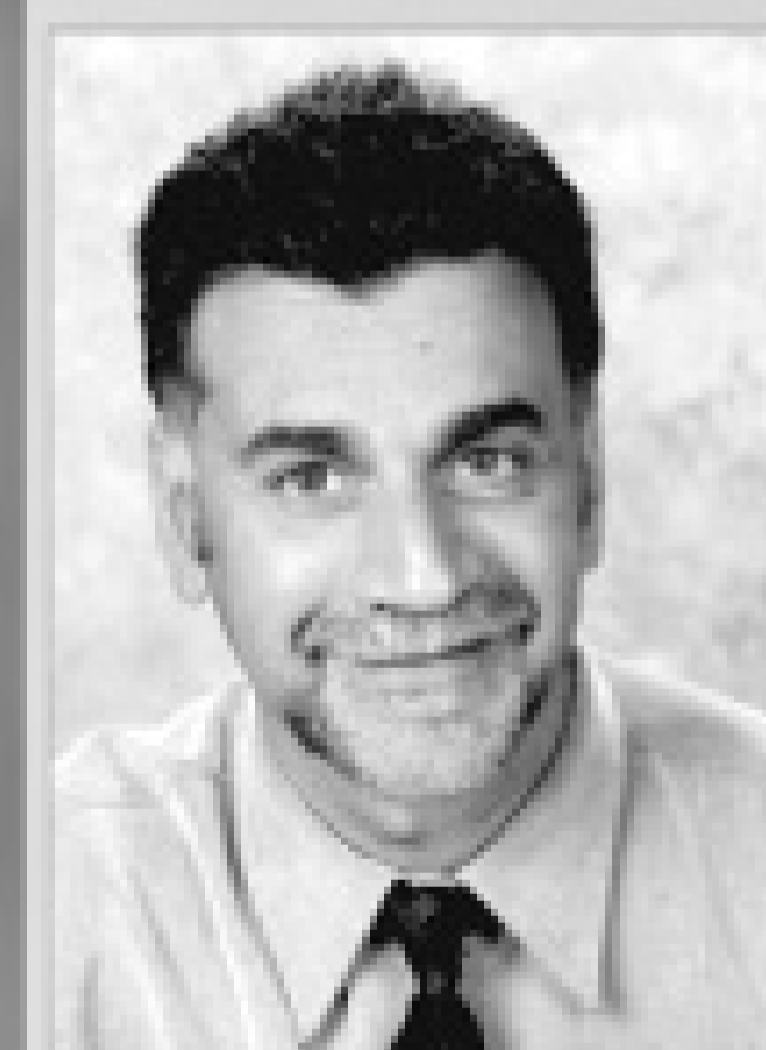

Chuck Territo



Mike Rausch

- \$250k Application Only
- Simple Approval Process
- Lease or Loan Options
- New & Used Equipment
- Flexible Finance Options
- Start Up Programs

Let us put our 35 years of experience to
work for you! Call today and see why...

It pays to lease with us!



Thank you for visit-
ing us in Louisville

Granite Leasing Co.

800.246.7997
www.graniteleasing.com

BEST ENTERPRISES, INC.



SOLD



SOLD



*It's all about
the Stainless
Steel!*



Slide-In Units available in many sizes including 400/200 & 300/110. We can customize your slide-in to meet your needs. Call us today or see us at the show.

1-800-288-2378



Thank you to everyone that came by our booth at the Pumper Show.

It was good seeing new faces and old friends.

We hope you all have a great year!

Gayle Humphries

Dan Marek

Best Enterprises, Inc.

3513 W. Mt. Springs Rd.

1-800-288-2378

PH: 501-988-1905

www.bestenterprises.net

Fax: 501-988-2880

Customer Wants to Flip His Lid

The pumper tells a homeowner that a riser in a cold northern climate will slow bacterial action in the tank ... Is he right?

This feature in Pumper reports noteworthy conversations that take place in Pumper Discussion, an e-mail based forum for industry professionals sponsored by COLE Publishing. Pumper Discussion provides for the exchange of information and ideas on septic and drainfield installation and maintenance, trucks and equipment, portable sanitation, chemical and additives, and much more. To find out more about Pumper Discussion, or to subscribe, visit www.pumper.com.

Information and advice in Overheard Online is offered in good faith by industry professionals. However, readers should consult in depth with appropriate industry sources before applying such advice to a specific business situation.

Overheard Online

DO RISERS BREAK TANK INSULATION?

Question:

I recently had my septic pumped. I told the (technician) I wanted to install a riser so we didn't have to dig up the lids every time we pumped. He said that wasn't a good idea in cold climates because of heat loss in the septic tank. He argued that the bacteria "slowed down" if the tank didn't maintain temperature.

Am I nuts? I haven't heard this before. Is he right?

Answers:

Looks like an opportunity for someone to make an insulated lid and riser system. I know here in northern Wisconsin the septic tank lid is the last place to accumulate snow and the first place to lose it. There is certainly heat loss through the lid — especially plastic lids. I routinely insulate my system with straw prior to winter to keep it from freezing in case we have a winter without much snow cover. Warmth does also promote bacterial growth.

It would seem to me that the colder the system, the slower the bac-

teria works or multiplies. It would also seem that the colder the septic water gets, the slower the bacteria reaches a cellular level. Isn't that why food lasts longer in the refrigerator and longer still in a freezer?

teria works or multiplies. It would also seem that the colder the septic water gets, the slower the bacteria reaches a cellular level. Isn't that why food lasts longer in the refrigerator and longer still in a freezer? If that were the case, then I would conclude that septic solids in colder climates break down more slowly and they would require pumping more often.

I wonder if in really cold weather like northern Minnesota, Alaska and northern Canada that the septic tanks are insulated — at least around the sides and on top?



When I installed my system, I put 2 inches of foam insulation over the top of the tank and inlet pipes before backfilling.

IS A BIGGER VACUUM TANK IN ORDER?

Question:

I have 2,000-gallon and 2,500-gallon vacuum tanks on my trucks and I'm thinking about buying a 3,600-gallon service truck. Most of my business is residential. I'm curious what kind of responses others get from residential customers to that size of truck. What's too big?

Answers:

I have one 2,000-gallon tank on a tandem axle and two trucks with 3,600-gallon tanks. We do about 1,200 homes a year. I might get four or five homes a year where I have to trim some tree limbs to get in. We keep trimmers on the truck. We encounter one or two jobs a year where the trucks are just too big. We carry 180 feet of 3-inch vacuum hose on the trucks.



Your report on limb trimming is right. Most large trucks also have tall exhaust stacks that can get in the way. If you're going to do mostly rural jobs, keep your trucks down to a 2,500-gallon or 33,000-pound gross vehicle weight ... unless you don't mind all the scratches and dings a large truck may suffer. ■

Celebrating 30 YEARS in business

Coagulants and Flocculants

for Septic, Grease, Municipalities and Industry

- Dewatering polymers for all dewatering equipment
- All forms: Dry and Emulsion
- Variety of packaging sizes to meet customer needs
- Both East & West coast shipping points
- Expert technical staff
- Specific solutions for our customers

Call Toll-free: 877.771.6041

Aqua Ben Corporation
1390 N. Manzanita St. • Orange, CA 92867
www.aquaben.com • sales@aquaben.com

Save Money
Save Time
Save Polymer

Thanks for visiting us!



VAC-CON

PRE-OWNED EQUIPMENT

MORE POWER TO YOU



2005 VAC-CON V321LHAD

- 2005 IH 7600
- CAT C-13 380 HP / 10-SPD
- 50 @ 3000 / DEUTZ 138 HP
- Mileage: 31,000

\$195,500



1997 VAC-CON V312THAE/1300

- 1997 Ford LNT8000
- 275HP / MD3060
- 50 @ 3000 Water Pump
- Mileage: 66,703

RECONDITIONED **\$120,000**



2004 VAC-CON V390LHAD

- 2004 International 7400
- IH 275 HP / Allison MD3060
- 50 @ 3000 / DEUTZ 138 HP
- Mileage: 11,000

RECONDITIONED **\$198,500**



1998 VAC-CON VPD3612LHA

- 1999 IH 2554
- 275 HP / Allison MD3060
- 80 GPM @ 2000 PSI
- Mileage: 116,000

\$125,000



2006 VAC-CON V312LHAD

- 2007 STERLING LT7501
- CAT 275 HP / Allison 3000RDS
- 50 @ 3000 / DEUTZ 138 HP
- Mileage: 23,000

\$209,500



2000 VAC-CON VPD3609SHA

- 2001 IH 2654
- 275 HP / Allison MD3060
- 60 @ 2000 / John Deere 4045T
- Mileage: Approx 45,000

\$145,000



2001 VAC-CON V312LHAD/1300

- 2001 Sterling LT9501
- CAT 380 HP / 10-Speed
- 80 @ 2000 / Cummins 110 HP
- Mileage: 73,000

RECONDITIONED **\$185,000**



1995 VAC-CON VPD3690THA

- 1995 FORD LN8000
- Cummins 250 HP / Allison MD3060
- 30 @ 3000 / John Deere 4039T
- Mileage: 57,500

RECONDITIONED **\$95,000**

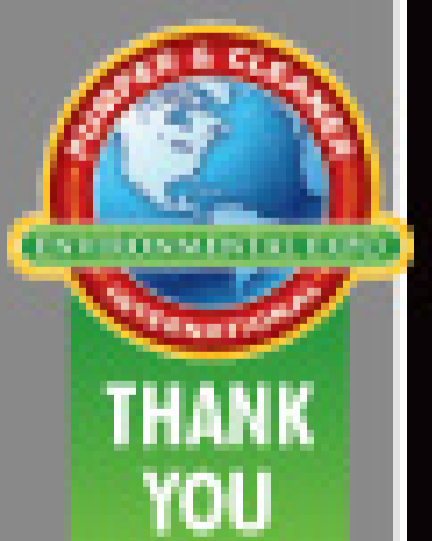

www.vac-con.com

Ultimate Lease

Ultimate Lease Hotline:
888-817.1757

969 Hall Park Drive • Green Cove Springs, FL 32043 U.S.A.
Tel: 904-284-4200 • Fax: 904-284-3305
www.vac-con.com • vns@vac-con.com

Wee Engineer

WITH IMAGINATION

Call us for a quote...

WE



2000 Ford F-650 (under CDL) Turbo diesel, 210 HP, 6-speed manual, 164,000 miles, PS/AC, 25,950 GVW. One yr-old **1500-gallon tank**, carbon steel, and a **One-yr-old MEC 8000 Battioni** 240 CFM vacuum pump, gearbox driven, automatic oiler, **NEW** 100-gal fresh water tank with 5-gpm demand pump. **NEW** hose reel Price**\$36,500**

Call us on this new tank.



We will find a good used truck or put it on a truck of your choice. It is a 3500-gallon, carbon steel tank.

 Thanks for visiting us in Louisville



Wee Vac The Wee
Vac fits through a standard doorway and can pump up to 45 gallons of grease at a time. It has a female cam-lock so it can be downloaded into your truck. It features a 110 volt vacuum pump. Price: **\$1,240**

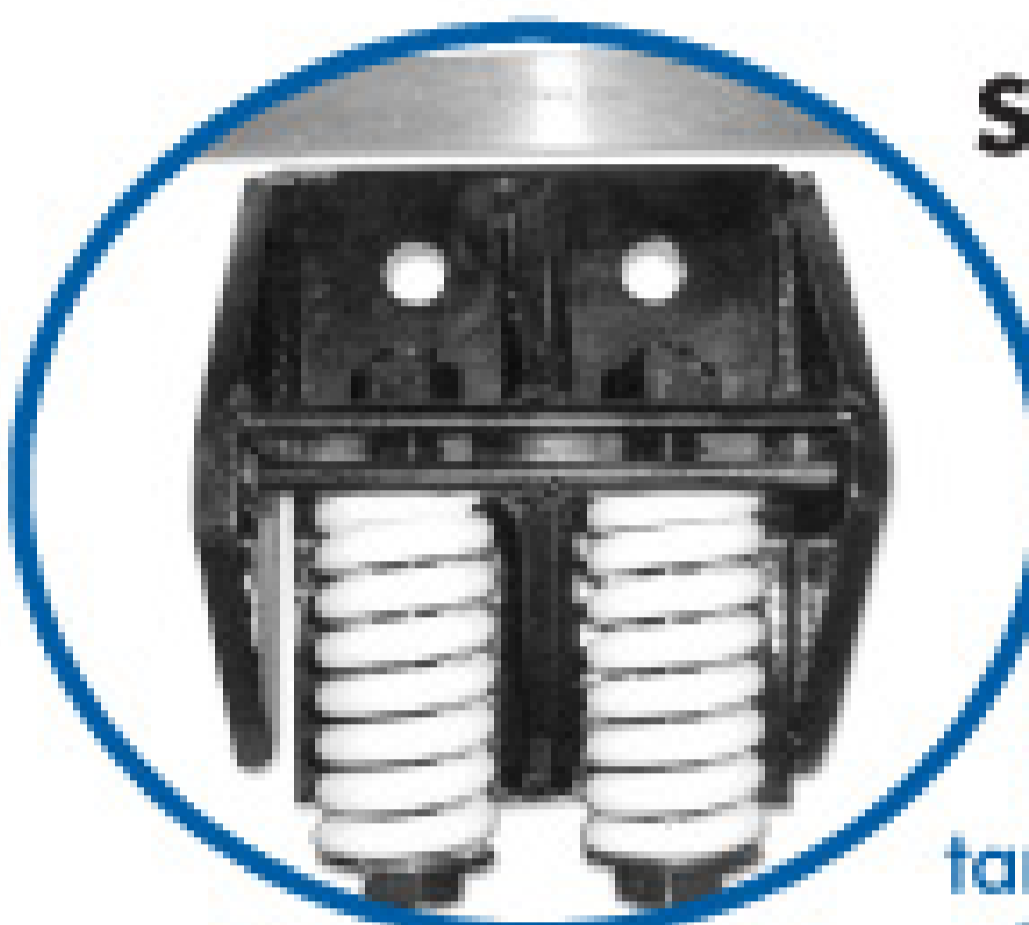

SPRING MOUNTS decrease fatigue on your tank frame, mounts to most tanks, Easy bolt or weld on style, Heavy-duty stress relieved springs.
Mounts with springs...**\$82.00**
Springs alone**\$11.00** each



Call us about this Portable Toilet Trailer 28-foot long, holds 14 standard units. Center fold-down T-bar accommodates handicap toilets. Includes locking toolbox, winch tiedown system, heavy-duty swivel jack. Price: **\$9,900**
Also available in 24' & 34' lengths.

P.O. Box 39 Dayton, IN 47941 Toll-Free: **877-296-2555** Phone: 765-296-2027 Fax: 765-296-3027
www.wee-engineer.com

ARMSTRONG EQUIPMENT INC.

MODEL 806B SEELEVEL ANNIHILATOR™

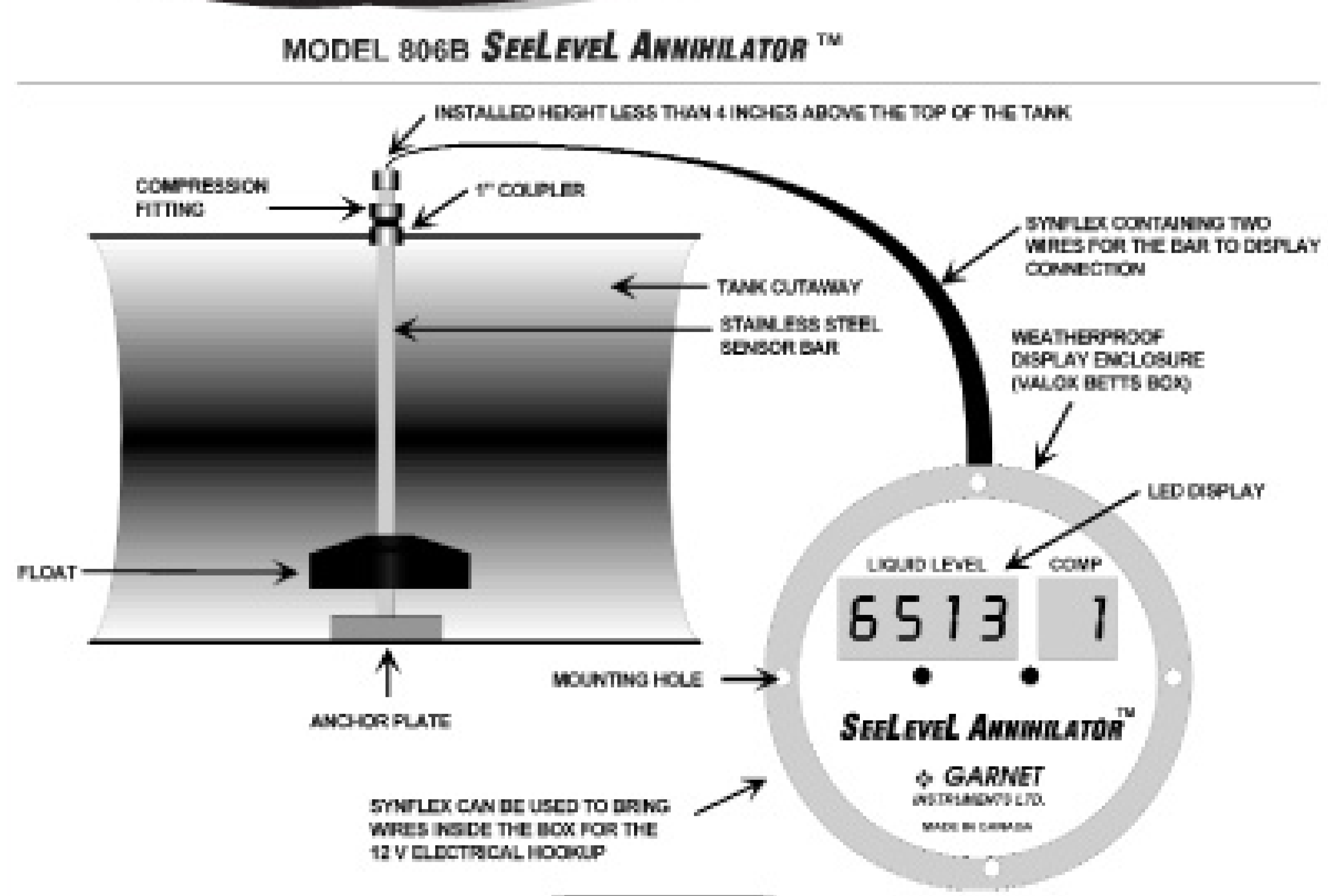

- **Accurate Readings to 1/4"**
Even with vacuum or pressure on the tank. No need to shut down pumping to check tank level.
- **Protect Your Pump, Avoid Spills**
See the level of your tank throughout the pumping process.
- **Work Safely**
Can be programmed to control warning devices.
- **Maximize Efficiency**
Avoid unnecessary trips. Can I get one more load, or should I head for the dump? The guessing game is over.
- **Plan Your Route**
Tracking customers tank size allows for improved route planning.
- **Communicate With Your Customers**
Pumping 1500 gallons from a 1000 gallon tank indicates problems

These are all good reasons to equip your next truck with a SeeLevel model 806B liquid level gauge system. The 806B can be programmed to read liquid levels in up to three compartments with only one display. It can also accept up to three alarm settings for triggering a warning light, sounding an audible alarm, or closing a loading valve; all while the tank is loading.



11200 Greenstone Ave. | Santa Fe Springs, CA 90670
800.699.7557 or 562.944.0404 | fax: 562.944.3636
e-mail: sales@vacpump.com | web: www.vacpump.com

To find out if the 806B can benefit your business, contact your tank manufacturer or call us
Toll Free at 1-800-699-7557

2009 V.E. Enterprises 'Raptor' Bobtail Tank



Why Choose A V.E. Enterprises Bobtail Tank?

Ten good reasons:

- 1. Built by ASME certified welders***
- 2. All vertical welds are sub-arc welded providing 100% penetration***
- 3. ASTM SA-36 grade 1/4" steel barrel, heads and baffles***
- 4. Barrel padded with 1/4" plate at all contact points***
- 5. 4" channel ring supports on barrel for 90, 100 barrel models***
- 6. Wider hose troughs with standard rear hose hooks***
- 7. Wedge shaped sump or loading lines with 4" butterfly valves***
- 8. Trailers prepped with steel shot blast creating a 2.5 mil anchor profile***
- 9. Primed and painted with DuPont Imron for the ultimate in durability***
- 10. Built for and by our customers; call us for available options***

** Available in sizes from 60 to 100 barrels; turn-key installations available through VE authorized dealers*

Setting the Standard For Liquid Storage and Transport Markets Since 1987.

800-234-2329

**www.veenterprises.com
sales@veenterprises.com**

10834 St. Highway 53 • P.O. Box 369 • Springer, OK 73458



ENTERPRISES, INC.

Industry NEWS

Hampel Names Bamberg Vice President

Dave Bamberg has been named vice president of business development for the portable sanitation division of Hampel Corp., Germantown, Wis. He has nearly 20 years of experience in the sanitation industry.

Infiltrator Adds Design Tools to Web Site, Unveils New Logo



Infiltrator Systems Inc. has added downloadable design tools to its Web site, www.infiltratorsystems.com, and unveiled a new company logo. The support design applications focus on the full line of TW Series septic tanks and Aquaworx Intelligent Pump Control panels.

Ritam Announces Expo Vacation Giveaway Winners

Hope and Kevin Anthony of Discount Portable Toilets of North Carolina were winners of the 2008 Expo Vacation Giveaway from Ritam Technologies. The couple received seven nights lodging at the Mayan Palace, Cancun, Mexico.

Zoeller VP of Marketing Retires

Mike Babrowski has retired as vice president of marketing after 26 years with the Zoeller Co. He was an active member of the Vendor Member Division and the American Supply Association, as well as other business and professional organizations in Louisville, Ky.



Mike Babrowski

SludgeHammer Receives NSF 40 Certification

The SludgeHammer aerobic bacterial generator has passed testing for NSF 40 certification. The six-month test consists of handling a daily minimum of 400 gallons of raw sewage effluent in a residential treatment system and producing an acceptable quality of effluent. ■



WESTERN SALES, LLC

WATER & WASTEWATER SOLUTIONS

Myers® Pumps & Parts



www.myerspumpparts.com

Vactor® Style Pumps & Parts

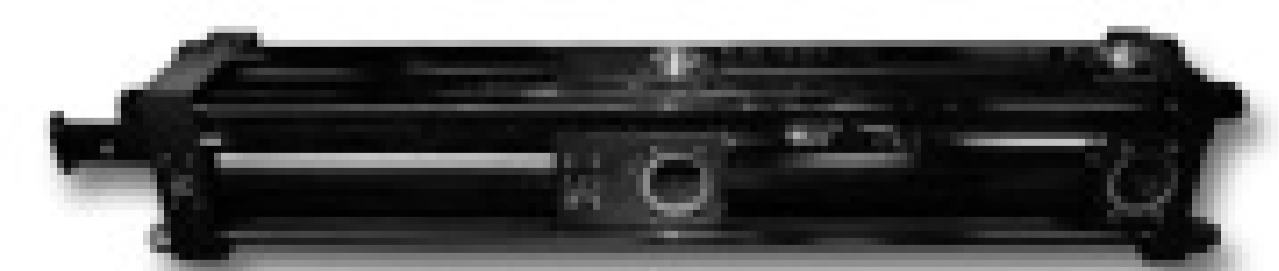

www.vactorstylepumpparts.com

Vactor® is a registered trademark of Vactor Manufacturing Inc., a wholly owned subsidiary of Federal Signal Corporation.

866-493-3406 Email: westernsales@cox.net



DENVER TRUCK SALES

Nobody Beats Our Quality!



2000 IHC 9400 & 9900

14,000 LB f/a, 3406E Cat 435-475 hp, Jake, 15-18 speed transmission, 46,000 LB rears Hendrickson air suspension. New 3360 gallon tank HXL-400 pump serviced and checked.
From \$62,950 plus F.E.T. on the tank



2001 Peterbilt 379

14,600 lbs. FA, C-15, 475 Cat, Jake, RTLO-18918 Transmission, RT-46160 on Pete air tract, 46,000 LB 4-way locks, New 3360 Gallon Tank, HXL 400 pump.
From \$79,950 Plus options and F.E.T. on the tank

Tanks Manufactured In House



1996-2001 Western Stars

435-475 hp Cat, Jake, 18 speeds 46,000 LB rears on Hendrickson air suspension. New 3360 gallon tank, HXL-400 Masport pump, serviced and checked.
From \$64,950 plus F.E.T. on the tank



2001-2003 KW T-800 Series

C15 Cat 475 hp, Jake, RTLO-16918 transmission, RT46160 46,000 LB 4.33 ratio, new 3360 gallon tank, Masport HXL-400 pump, new paint serviced and checked.
From \$79,950 plus F.E.T. on the tank

Complete Lines of Pumps and Parts

Easy Financing and Lease-To-Own WAC!

Denver Truck Sales • 5293 Vasquez Blvd. • Denver, CO 80216
Phone: 303-291-0960 • Fax: 303-291-0244 • www.denvertruck.com



2.2 Meter Belt Filter Presses
Trailer Mounted

Grease Trap Waste
Septage Waste



Rentals

Mobile Units Skid Systems

www.brightbeltpress.com



PUT THE SQUEEZE ON WET WASTE ...

Building A World of Solutions

Blower Repair



Waterblast Rentals

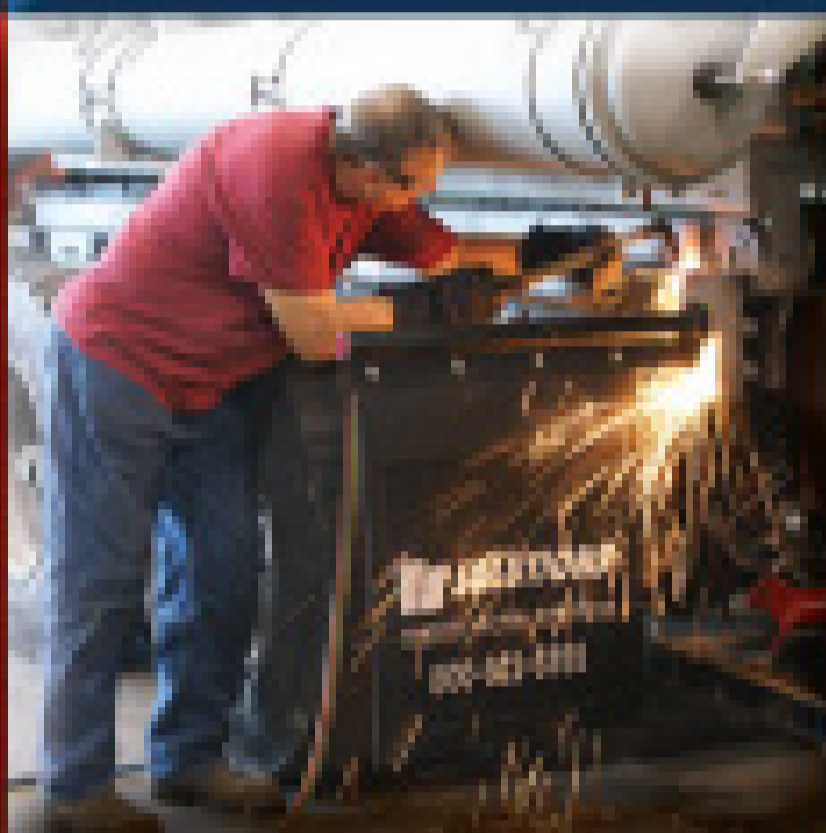

Equipment Refurbish



Parts



Used Equipment



Accessories

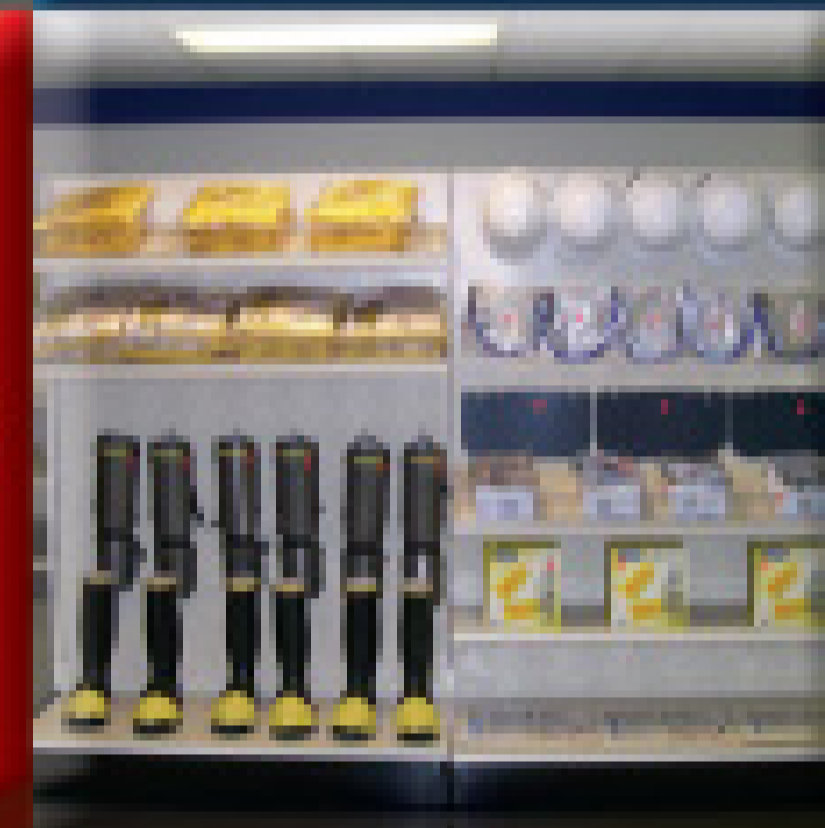

Training



Huge Selection of Used & Refurbished Trucks!



Unit #05123 1997 Guzzler ACE,
 Roots 1021 DVJ 27", New Paint,
 Hydraulic Boom
READY TO WORK!



Unit #44184 2005 International 7600,
 Guzzler Classic, New Debris Body,
 New Hibon SIAV 8702 Blower
READY TO WORK!



Unit #K2534 2009 Sterling 7501,
 Keith Huber Liquid Vac, Demag Rfl
 100 Pump, 3000 Gallon Debris Tank
READY TO WORK!

Many More Units Available • Warranties for Most Equipment we Sell and Service

1.800.822.8785 www.fssolutionsgroup.com

10280 Brecksville Road Brecksville, Ohio 44141



R.A. ROSS N.E., INC.

INDUSTRIAL & TRUCKING BLOWERS • VACUUM PUMPS • SALES, SERVICE, & INSTALLATION



We have a **FULL SERVICE REPAIR SHOP** capable of servicing and repairing a wide variety of different makes and models of blowers and vacuum pumps from all your top manufacturers including
**Tuthill/MD • Drum • Gardner Denver • Cycloblower • Duroflow • Sutorbilt • Roots • Hibon
 Fruitland • Moro • Masport • Wittig • NVE Challenger • Jurop • Battioni • Presvac
 Blackmer • Roper • Ranger • Viking**

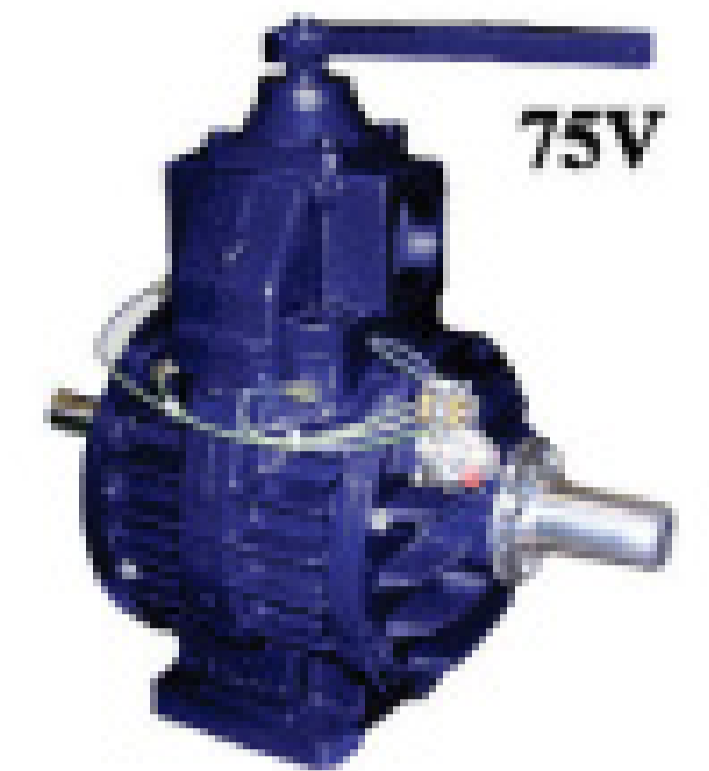
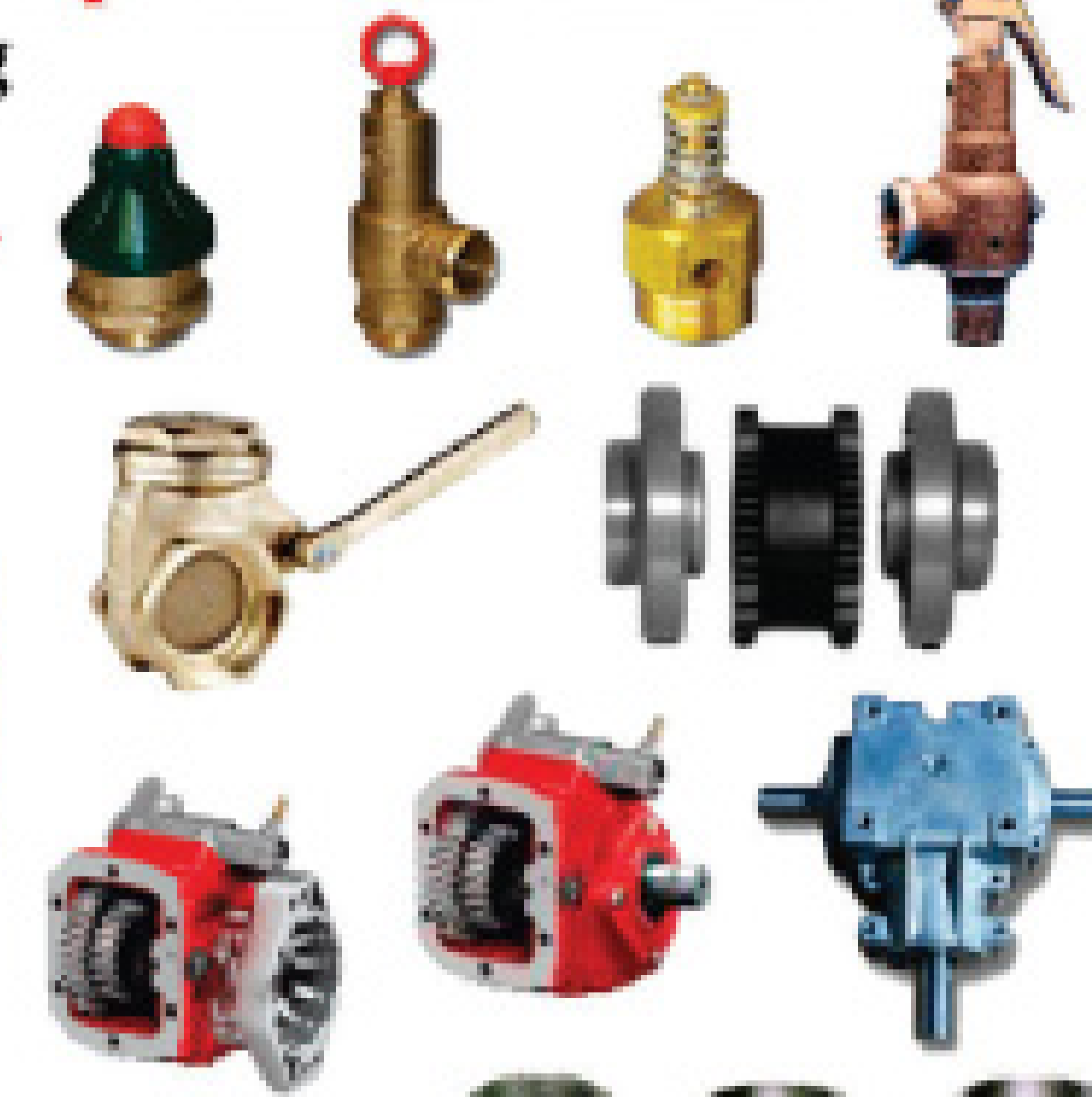

NVE FRUITLAND CHELSEA
A DIVISION OF Parker



Vacuum Pumps • Components • PTO's • Hydraulics • Valves • Manways • Gear Boxes • Mufflers • Silencers • Gauges • Camlocks • Hose

TOLL FREE 1.800.678.4581 PHONE 440.546.1190 FAX 440.546.1188 EMAIL RAROSSNE@RAROSSNE.COM WEBSITE WWW.RAROSSNE.COM

SOFTWARE FOR THE INDUSTRY



**Business Efficiency
 ...NOW more than ever!**

Summit™ XP Service Profit Builder™

- Work Orders
- Job History
- Reminders
- Diagrams
- Dispatching
- Instant Mapping
- Inventory Control
- Receivables
- Automatic Credit Card Processing
- Commissions
- Repeat Business
- QuickBooks® Link
- ...and much more!



**Easiest to use!
 ...Over 25 years
 experience**

*Let us transfer the data
 from your old program!*

Stay on Top...with Summit™!

- Ask about our other software programs for:
- Portable restrooms & other rental businesses
 - Sales contacts for sales personnel
 - Employee incentive tracking
 - Fleet maintenance and service tracking

DEMOS ON LINE!...or call for a Demo DVD or personal guided tour



Ritam Technologies, LP
 Sales: USA 800-662-8471 • Int'l: 208-629-4462
 Email: info@ritam.com • Web: www.ritam.com

We Have Money To Loan



If you need equipment to grow and your bank said "NO," call "JIM THOMAS"

We are not affected by the economy. Conserve your working capital. Keep existing credit lines intact, and enjoy the security of knowing financing is there when you need it. We offer loan and leasing plans tailored to individual needs.

- Portable Toilets
 - Sewer Equipment
 - Pumper Trucks
 - TV Inspection
 - Water Jetters
 - New and Used Equipment
 - Vacuum Trucks
- ❖ Programs offer longer terms for older equipment.
 - ❖ We do start ups.
 - ❖ 90 Day Delayed Billing.
 - ❖ Seasonal Payment Programs Available

Get Pre-Approved for the Pumper & Cleaner Environmental Expo

Prompt, no nonsense financing designed to meet individual requirements. Payment plans that are generally lower than other finance plans. With years of experience, we understand the competitive nature of your business.
 We're prepared to act quickly and decisively!

Toll-Free 877-333-4539 • www.keycommercial.com



KEY COMMERCIAL CORP.

Commercial Equipment Leasing

"Getting You The Credit You Deserve"

TRANSPORT TRUCK SALES, INC.

Ask for Scott or Frank – 888-395-7551
After hours call Scott at 816-590-4076

TTS

What Does It Take To Be A "Qualified Chassis"?

Pass our 12 point checklist. (We send this out with every quote!)

Pass a D.O.T. certified inspection!

Pass the warranty inspection!

What Does All This Do For You?

Nationwide drive train warranty for 2 years/ 200K miles! (restrictions apply)

A tough truck that is ready to work as hard as you do!

YOUR TRADES ARE WELCOME!

Searching For A Brand New Chassis?
We Have Them In Stock!



2002 Freightliner FL-112, CAT C-10 350 HP, 9 spd, jakes, 14,600# fronts, AC, double framed, new 3600 gallon Alum. vac tank, new Masport HXL-400 vac Pump.

Call For Pricing!

2-YEAR 200,000 MILE DRIVE TRAIN WARRANTY



2002 International 9200i, CAT 380 HP, jakes, 10 spd, double framed, AC, new 3360 gallon steel vac tank, new Masport HXL-400 vac pump.

Call For Pricing!

2-YEAR 200,000 MILE DRIVE TRAIN WARRANTY



2002 Mack CH613, E-7 400 HP, 10 spd, jakes, AC, double framed, LOW MILES, new 3360 gallon steel vac tank, new liquid cooled Masport HXL-400 vac Pump.

Call For Pricing!

2-YEAR 200,000 MILE DRIVE TRAIN WARRANTY



2001 Mack CH613, E-7 300 HP, 10 spd, AC, double framed, new 3360 gallon steel vac tank, new liquid cooled Masport HXL-400 vac Pump.

Call For Pricing!

2-YEAR 200,000 MILE DRIVE TRAIN WARRANTY



2001 Mack CH613, E-7 380 HP, 10 spd, jakes, AC, double framed, LOW MILES, New 3360 Gallon Steel Vac Tank, New Liquid Cooled HXL-400 Masport Vac pump.

Call For Pricing!

2-YEAR 200,000 MILE DRIVE TRAIN WARRANTY



2000 Freightliner FLD120 Severe Duty, 12.7L Detroit 430 HP, 13 spd, jakes, double framed, 18# fronts, 46# rears, new 3360 gallon steel vac tank, New Liquid Cooled HXL-400 Masport vac pump.

Call For Pricing!

2-YEAR 200,000 MILE DRIVE TRAIN WARRANTY

Delivery Available Anywhere in the Lower 48!!

Too Extreme? Or About Time?

The National Safety Council proposes a blanket ban on cell phone use while driving

By Ted J. Rulseh



The National Safety Council has not only called on motorists to stop using cell phones and messaging devices while driving — it is urging businesses to enact policies prohibiting those practices, and asking governors and legislators in all 50 states and the District of Columbia to pass laws banning them.

Safety First

In a January news release, NSC president and CEO Janet Froetscher observed, “Studies show that driving while talking on a cell phone is extremely dangerous and puts drivers at a four times greater risk of a crash. Driving drunk is also dangerous and against the law. When our friends have been drinking, we take the car keys away. It’s time to take the cell phone away.”

It would be a mistake to underestimate the NSC’s credibility or effectiveness. The council led the adoption of the “Click It or Ticket” seat belt campaign from a one-state pilot project to a 50-state program. “We believe the same kind of culture and behavior change must — and can — be achieved to stop cell phone use while driving,” Froetscher says.

ANOTHER DISTRACTION

The NSC puts cell phone usage in the larger category of distracted driving. The council observes that driver inattention is a leading cause of traffic crashes. The National Highway Traffic Safety Administration says driver inattention is responsible for about 80 percent of all collisions.

And cell phone use, hands-free or not, is a major source of distraction, the NSC argues. The council cites a study from the Harvard Center of Risk Analysis estimating that cell phone use while driving contributes to 6 percent of crashes, which equates to 636,000 crashes, 330,000 injuries, 12,000 serious injuries and 2,600 deaths each year.

The study also put the annual financial toll of cell phone-related crashes at \$43 billion.

Talking on a cell phone may be less distracting than some other activities people engage in while driving, but the use of cell phones and texting devices is much more pervasive, making it more dangerous overall, Froetscher states.

The NSC also points to studies from the University of Utah showing that hands-free devices do not make cell phone calls while driving safe. “Another study demonstrates that talking to passengers, as opposed to talking on a cell phone, actually makes adult drivers safer, because passengers help alert drivers to potential driving risks,” the news release says.

Froetscher adds, “When you’re on a call, even if both hands are on the wheel, your head is in the call, and not on your driving. Unlike the passenger sitting next to you, the person on the other end of the call is oblivious to your driving conditions. The passenger provides another pair of eyes on the road.”

“Studies show that driving while talking on a cell phone is extremely dangerous and puts drivers at a four times greater risk of a crash. Driving drunk is also dangerous and against the law. When our friends have been drinking, we take the car keys away. It’s time to take the cell phone away.”

Janet Froetscher

BIG USE IN BUSINESS

The NSC acknowledges that a significant amount of vehicular cell phone use occurs on the job. “Many businesses have already acknowledged the injuries and costs associated with this behavior by adopting policies that ban cell phone use by employees on the roads,” the council states.

Among NSC member businesses that responded to a survey, 45 percent said they have company policies prohibiting on-road cell phone use. Of those, 85 percent said the policies make no difference in business productivity.

“Anyone with a busy job knows the temptation to multi-task and stay in touch with the office while driving,” Froetscher says. “Believe me, I’ve been there. I didn’t realize how much risk I was taking. Most people don’t. Employers understand how dangerous the behavior is and their potential liability. We are asking all businesses to join us by adopting policies banning calling and texting while driving on the job.”

Froetscher has sent letters to all governors and state legislative leaders encouraging them to adopt statewide bans. She acknowledged that achieving and enforcing bans in all states will be a challenge, but she said the NSC has successfully faced similar challenges in the past — including seat belt enforcement.

‘THERE WILL BE A DAY ...’

“It may be hard for some people to imagine how certain laws, such as those concerning drunk driving, teen driving, seat belt use and booster seats, can be enforced by observation alone,” Froetscher said. “Smart people in law enforcement get together to address such issues. They develop creative and successful measures to identify violators, such as high-visibility enforcement strategies.”

The NSC will take a three-fold approach to leading change: advocating legislation; educating the public and businesses about the risk of cell phone use while driving; and supplementing distracted driving content in its training of 1.5 million people annually in defensive driving.

“The change we are looking for, to stop cell phone use while driving, won’t happen overnight,” Froetscher says. “There will be a day, however, when we look back and wonder how we could have been so reckless with cell phones and texting devices.”

For a fact sheet, data resources and other information concerning cell phone use while driving, visit the NSC website at www.nsc.org. ■

The All-New Sunrise!



Durable, affordable with style that's out of this world.



Hampel

Engineered for strength, durability and value.

www.hampelcorp.com • 800-549-1558

Experience Matters.

Custom vacuum tanks built to your specifications.

For nearly 50 years, our tank builders have been setting the industry standard for innovation and value. Everything we build is customized to your exact specifications. Start with a bare tank and add only the options that are suitable for your application. What about service? Our technicians can rebuild pumps or furnish parts such as vanes, seal kits, housings, and rotors for most pumps. Whatever you need, let us put our experience to work for you.



Bare tank w/no attachments

Bare Tank:

Prices are for the tank only with no openings, hatches, rails or other attachments. LMT can furnish items for you to attach to your tank at additional cost. Please call for more information and pricing.



Basic tank w/optional manway and hose trays

Basic Tank:

Prices include primary shutoff, full length rails (straight or tapered), 4" discharge nipple, and 3" intake nipple.



Thanks for visiting us!

Check out some of the options:

- ✓ Manways (20", 25", 36")
- ✓ Full open door (2 types)
- ✓ Primary & secondary shutoffs
- ✓ Valves for loading & unloading
- ✓ Oil catch mufflers
- ✓ Suction hose & couplings
- ✓ Mounting rails & kits
- ✓ Vacuum pumps (Jurop, Masport, Moro, Fruitland, and others)
- ✓ Hose trays and hangers

And more...

LMT Basic & Bare Tank Prices:

(subject to change without notice)	Basic Tank	Bare Tank
1500 gallon: 54" dia. x 12' long w/1 baffle.....	\$ 5,150.....	\$ 3,765
2000 gallon: 60" dia. x 14' long w/2 baffles.....	6,200.....	4,850
2500 gallon: 66" dia. x 14' long w/2 baffles.....	7,100.....	5,700
3000 gallon: 68" dia. x 14' long w/2 baffles.....	8,000.....	6,570
3500 gallon: 72" dia. x 17' long w/2 baffles.....	9,550.....	8,030
4000 gallon: 78" dia. x 16' long w/2 baffles.....	10,685.....	9,125
4200 gallon: 78" dia. x 17' long w/2 baffles.....	11,170.....	9,580

Custom sizes up to 6000 gallon are available.

All lengths are can length excluding flanged and dished ends. All tanks over 70" dia. have 2 braces of 2" x 3" solid steel to prevent collapse of tank. All tanks are cleaned with an acid solution and prime painted. We can also customize the paint color for an extra fee. Tanks are manufactured with mild steel and are welded with submerged arc process for the best strength and appearance. Stainless steel is available at extra cost.



Call us at 800-545-0174 before you buy!

LMT Inc. - Custom Vacuum Tanks

Tel: 309.932.3311 • Fax: 309.932.3155 • info@tanksandpumps.com

www.tanksandpumps.com

Custom Built YOUR Truck or Pull-type Chassis or OURS



- Septic Systems
- Municipal Waste Control
- Ag Operations
- Supplier for Brass or Stainless Steel Gate Valves
- Vacuum Pumps of All Sizes

Call Kevien Schroeder Today! 1-800-795-8551 ext. 124

Vertical Electric Pump

Agitate, transfer or top fill hauling units. Choose from standard lengths of 4' - 6' - 8' - 10' - 12', other sizes available upon request

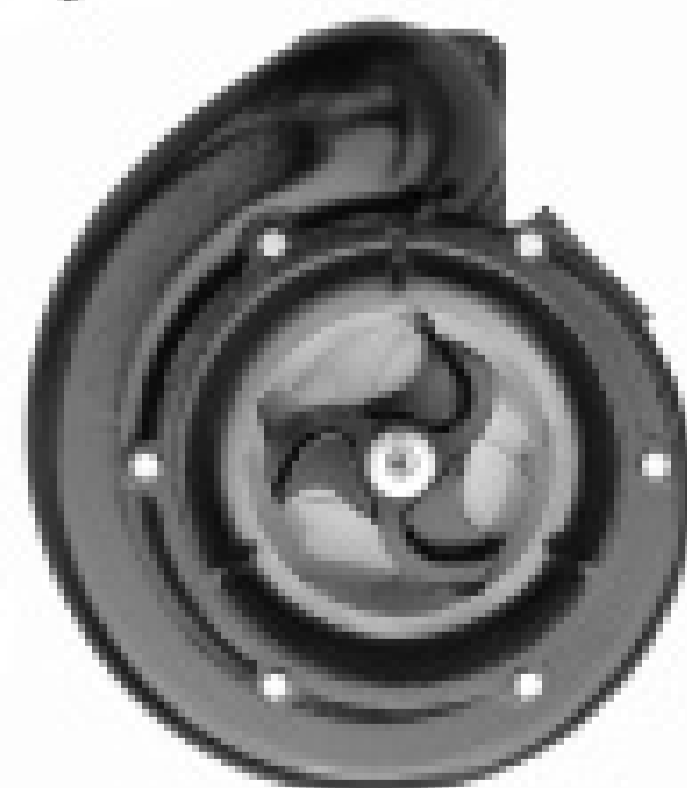

Galvanized Construction!

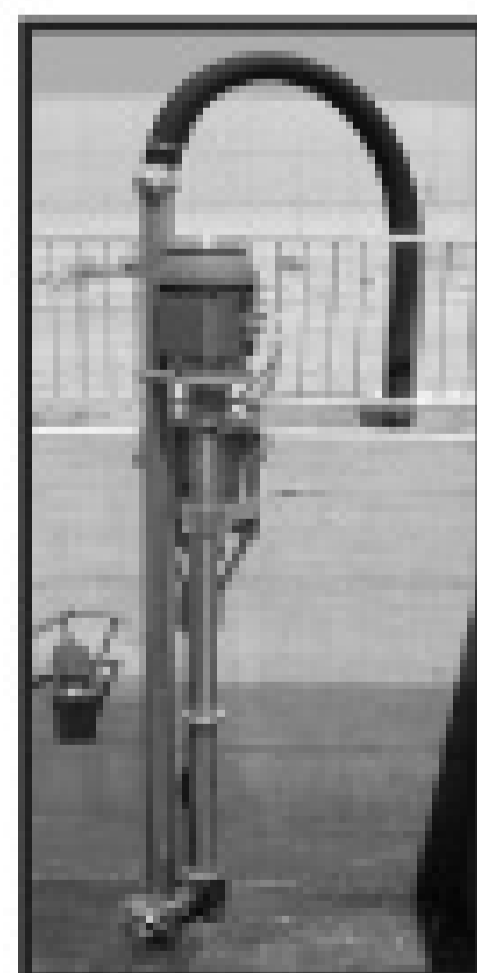

BALZER INC.
STEWARDS FOR **AG** ENVIRONMENTS

CO. RD. 27, Box 458
Mountain Lake, MN 56159
1-800-795-8551
www.balzerinc.com

Seal it Tight! Seal it Easy! Seal it Fast!



- Easy 10 minute installation!
- Secure fit for all systems!
- Made & sold by septic installers!
- Prevent ground water infiltration and save money at the same time!



Apply foam sealant to tank.



Place ring over opening and apply foam.



Place plastic riser pipe over ring.



Install lid.

Are you tired of using risers that are too tall or too short for the job you are completing? Plastic riser pipe will give an exact height each time. Try our system and you will never have to carry concrete pipe and lids again. Save time by not having to assemble multiple sections.

- Seal-R® Lids Available in 12", 15", 18", 24", 30", 36".
- Seal-R® Rings Available in 18", 24", 30".
- Inner Safety Lids Available in 18", 24".

Seal-R® Lids can be personalized. Seal-R® Lids are constructed with UV additive to resist degradation from exposure to sunlight.

For more information, call us today!

BrenLin Company, Inc.
Manufacturers of Seal-R® Products
Herman, MN
888-606-1998

Fax 320-677-3001 • Email: brenlin@brenlin.com

www.seal-r.com

J-DISKS

Instant Fragrance Power!



Biodegradable J-Disks contain concentrated fragrance oils that enhance and compliment our deodorizers. Our J-Disks are designed to give your units a powerful fragrance punch!

Call our customer service team for more details.

1-800-345-3303

www.jjchem.com

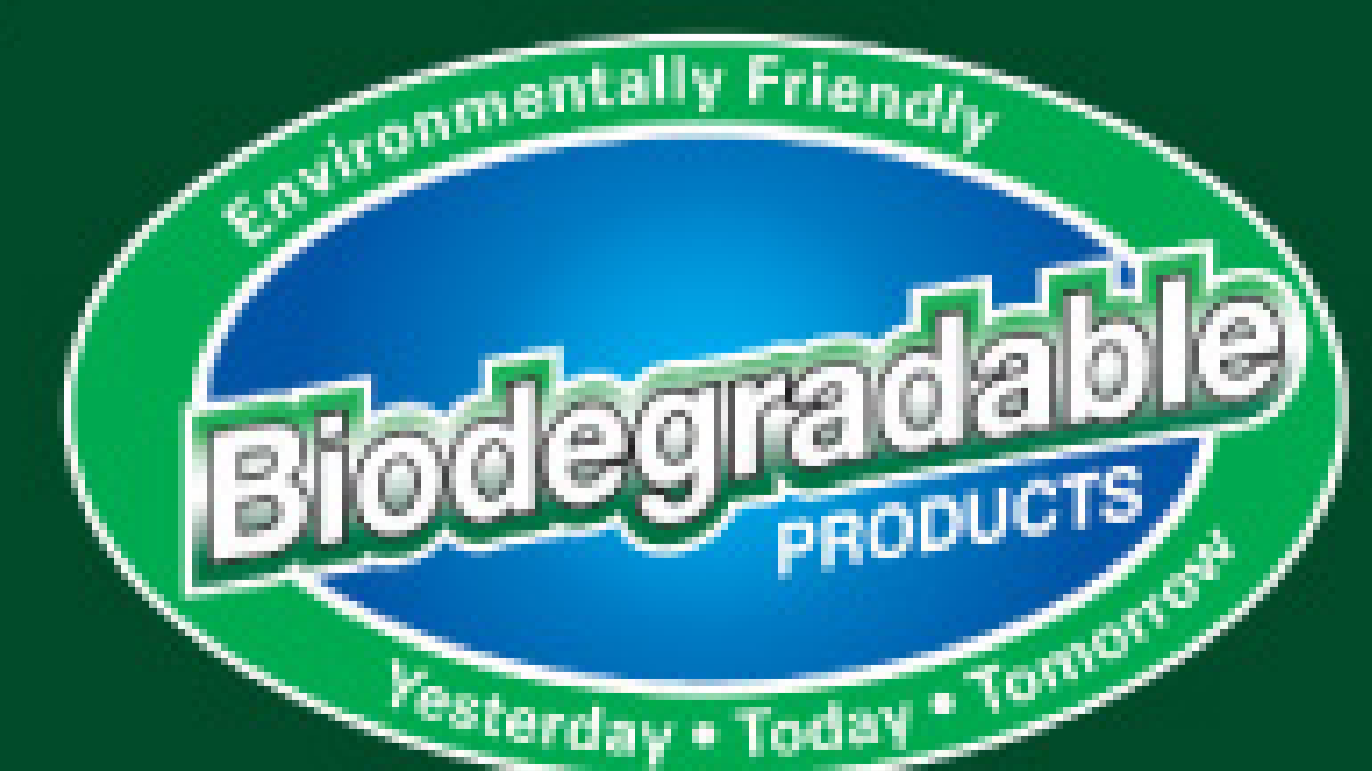



Classy Truck of the Month

**Kerkstra Septic Tank
Cleaning Inc.**
Hudsonville, Mich.

Comforts of Home
Services, Inc.

LUXURY TRAILER SALES

Units come with A/C, Heat, HD Steps and a Large 300 Gallon Waste Tank

- Lowest Interior Floor Height in the Industry
- ADA wheelchair accessible units.
- Unlimited Floor Plans from 8' to 53' Trailers
- Rigid Steel Shell Construction from top to bottom to resist rot and warping.
- Specializing in Customizing trailers to fit your needs.
- Easy Fold-Up Steps & Door Handles
- 24/7 Tech Support for the best customer service available.
- Free Nation Wide Lead Program for our customers.
- Large Capacity Waste Tanks
- High Privacy Partitions are Standard for Added Comfort
- Rigid Platform, our smallest wide body trailers start out with Dual 10" ASTM I-Beams.

See our website for more layouts and options.

8' 2-Station w/A/C & Heat - 300 gal waste

12' 2-Station Combo w/A/C & Heat - 450 gal waste (includes Showers)

20' 6-Station w/A/C & Heat - 600 gal waste

24' 7-Station ADA w/A/C & Heat - 750 gal waste

INFO@COHSI.COM • 877.382.2935 • WWW.COHSI.COM

This big red vacuum service truck makes a real statement rolling down the road for Kerkstra Septic Tank Cleaning Inc. The 1998 Peterbilt 377 has a 4,500-gallon aluminum tank from Imperial Industries and a 367 Challenger vacuum pump. The heavy hauler is powered by a 425-hp Cummins N14 engine with a 10-speed Eaton-Fuller transmission. It has a locking differential and dual stacks. Kerkstra bought the Pete in 2007, which had previously served as an over-the-road semi. The company did much of the work on its own to transform it to a day-cab rig, removing a sleeper and fifth-wheel plate and installing a custom patch panel for the cab. Kerkstra stretched the frame, installed a lift axle and painted the truck before taking it to Imperial, where the tank was fitted and painted the metallic maroon color used for the entire Kerkstra fleet. The truck has aluminum wheels and toolboxes, heated valves and hose trays sprayed with a bedliner. The truck carries 200 feet of hose so it can stay off driveways and lawns. Graphics were done by Mark Oesch.

Show us yours!

Got a truck with real WOW appeal? Show it off to Pumper readers — and to the whole world through www.pumper.com!

Send photos of your truck after it has been lettered with your company name, and please pose the owner(s) with the truck. Any industry-related truck is acceptable. Please limit your submission to one truck only.

Your submission must include your name, company name, mailing address, phone number, and details about the truck, including tank size, cab/chassis information, pump information, the company that built the truck, and any other details you consider important. In particular, tell us what features of the truck help make your work life more efficient and more profitable. E-mail your materials to editor@pumper.com or mail to Editor, Pumper, P.O. Box 220, Three Lakes WI 54562. We look forward to hearing from you!



49 YEARS OF DEPENDABILITY

TUFF-JON



- Deep Basin, can easily wash your arm
- Rides inside portable Restroom for space saving transport
- Fully enclosed 20 gallon fresh water tank
- Foot Pump, Towel Dispenser & No Mess, No Waste Soap Container
- 2-12" wheels and built in handle for roll-a-round capabilities



INTRODUCING ...
**TJ Junior
Single Free
Standing Sink**

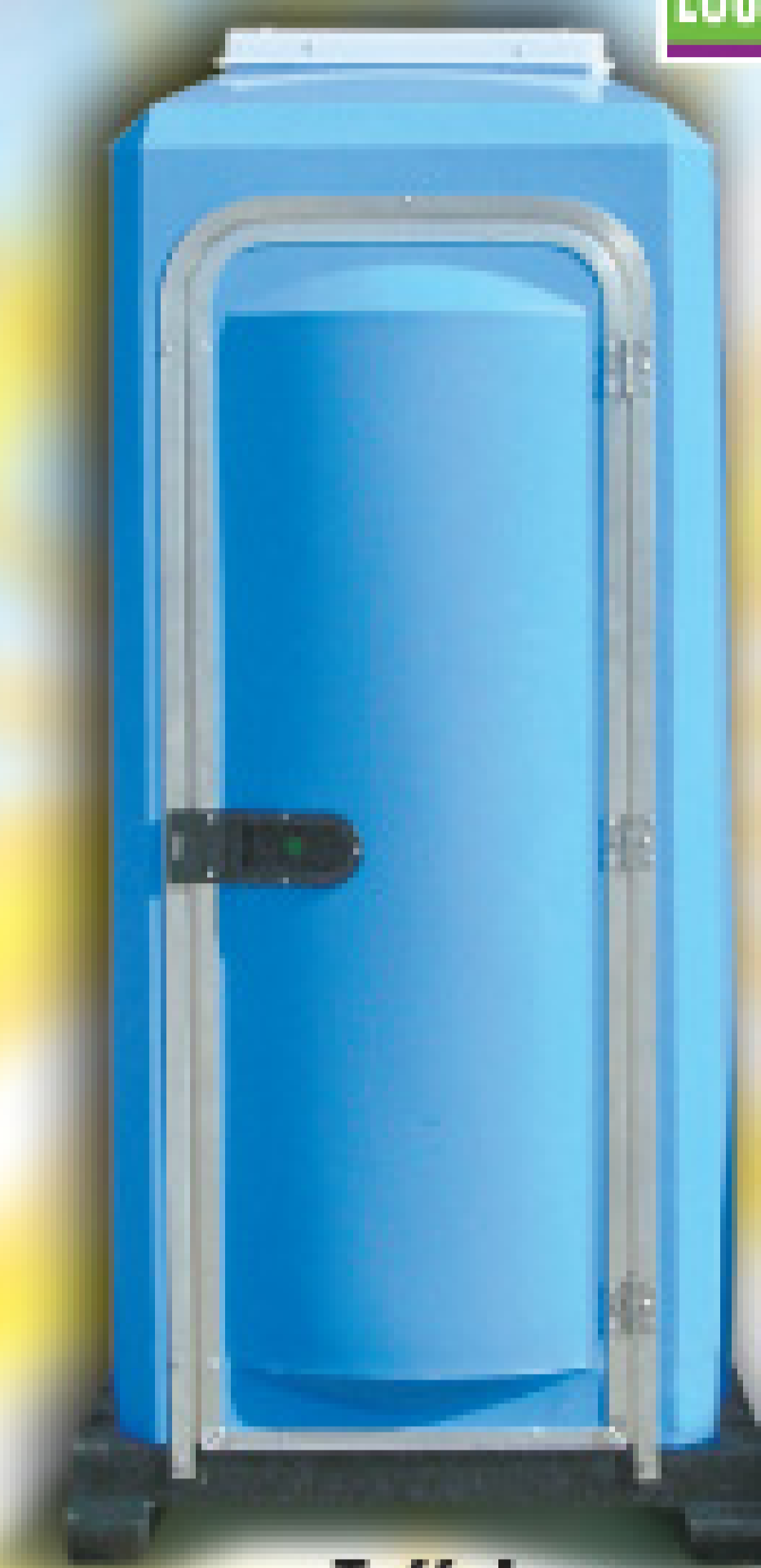

Tuff-Jon



Tuff-Jon III



60 Gallon Rinse Tank



Tanks in 60, 105, 225, 300 and 440 Gallon Sizes

- One-Piece Construction
- Lightweight
- Rust-Free Hardware
- Wood and Poly Skids
- Large Variety of Colors

— OPTIONAL ACCESSORIES —



7-1/2 Gallon Handwasher



Tuff-Jon with Lifting Bracket Assembly



90 Gallon Free-Standing Sink



Sky Heater



Sinks available for the Tuff-Jon III

The TSF Company Inc. | 2930 S St. Phillips Rd. | Evansville, IN 47712

Toll Free: **1-800-843-9286** | **812-985-2630** | Fax: **812-985-3671**

E-mail: **tsftuffjon@sbcglobal.net** | Web Site: **www.tuff-jon.com**



PORTABLE TOILETS / HOLDING TANKS / HAND WASH UNITS / ACCESSORIES

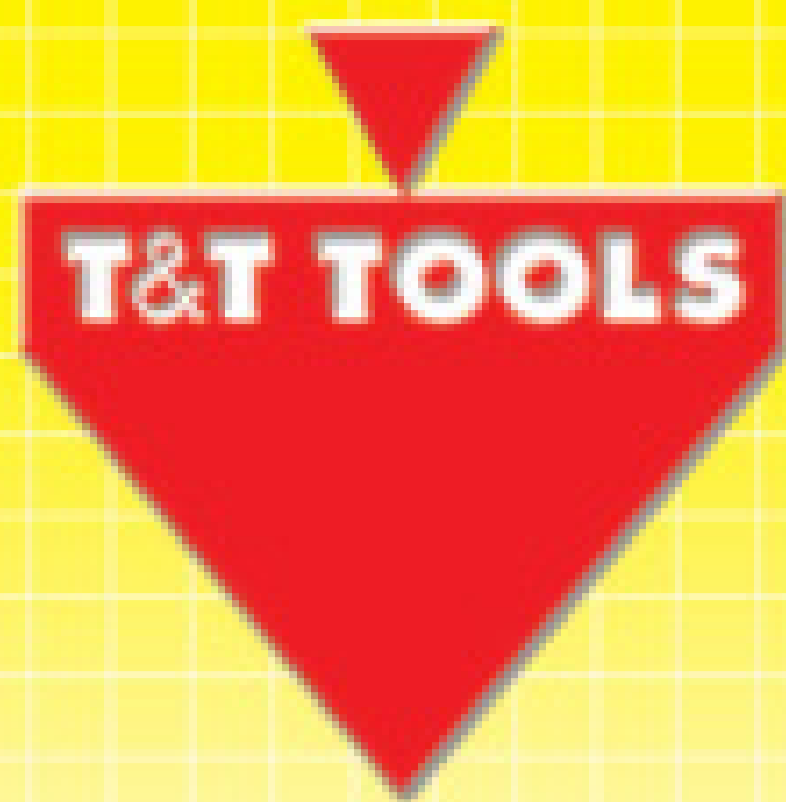

T&T Tools, Inc.

Fax: 800.521.3260
Email: sales@tandttools.com

800.521.6893

www.MightyProbe.com



HOOKS...

- > Several different styles of heat-treated hooks are available
- > Top Poppers are great to open manhole covers
- > The Handy Hooks allow two handed use

PROBES...

- > Insulated, standard, and specialty soil probes
- > Metal shaft sizes: 3/8" round, 3/8" hex, or 7/16" hex
- > Replaceable tips are threaded on and hardened
- > A "slide" allows the handle to pound the shaft into the ground

We Do Industrial

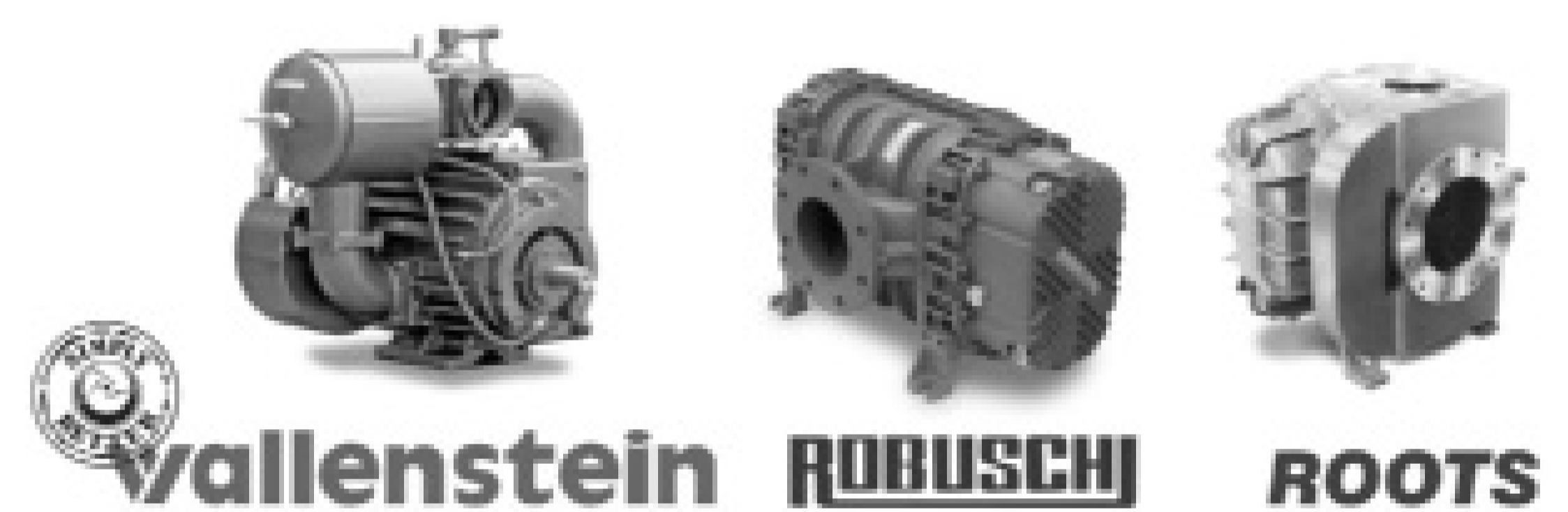

Rotary vane and blower packages available



vacutrux

20 Martins Ln ELMIRA, ONTARIO, N3B 2A1
phone (800)-305-4305, (519) 669-1625
fax (519) 669-8331 salesinfo@vacutrux.com

DOT/TC 407/412
code tanks available



A direct reflection of people who care...

*Did I mention our
trucks and equipment
are CUSTOM built
to fit your individual needs?!*



#1 QUALITY

#1 DESIGN

#1 SERVICE

#1 EQUIPMENT

GapVax®

The GapVax® cyclone design makes our unit a True Single Mode Vacuum Truck. Smaller diameter cyclones give greater centrifugal force that cleans the air more efficiently. Since relatively little material enters the baghouse, the filter bags stay cleaner longer, and they do not clog up with material which provides maximum vacuum at the work hose –this also saves on fuel. PLUS - GapVax® manufactures the only vacuum equipment on the market with NO VISIBLE DUST EMISSIONS!

2009 marks our 20th anniversary



CHECK US OUT AT WWW.GAPVAX.COM OR GIVE US A CALL TOLL-FREE AT 888-442-7829.

Truck and Driver

Proper training will help truck drivers protect themselves from injury and the expensive equipment they operate

By Mary Shafer

Any smart employer knows that his or her largest investment is tied up in the hiring and retention of quality employees. And in an industry like this, which depends so heavily on the consistent performance of large, specialized vehicles, it's a no-brainer where the other big bucks get spent.

So what do we do to protect these major investments in our businesses? The answer appears to lie in training, the kind that goes above and beyond the simple mechanics of the job. It's about building up and maintaining the safety and viability of both types of assets — human and mechanical — over the long haul.

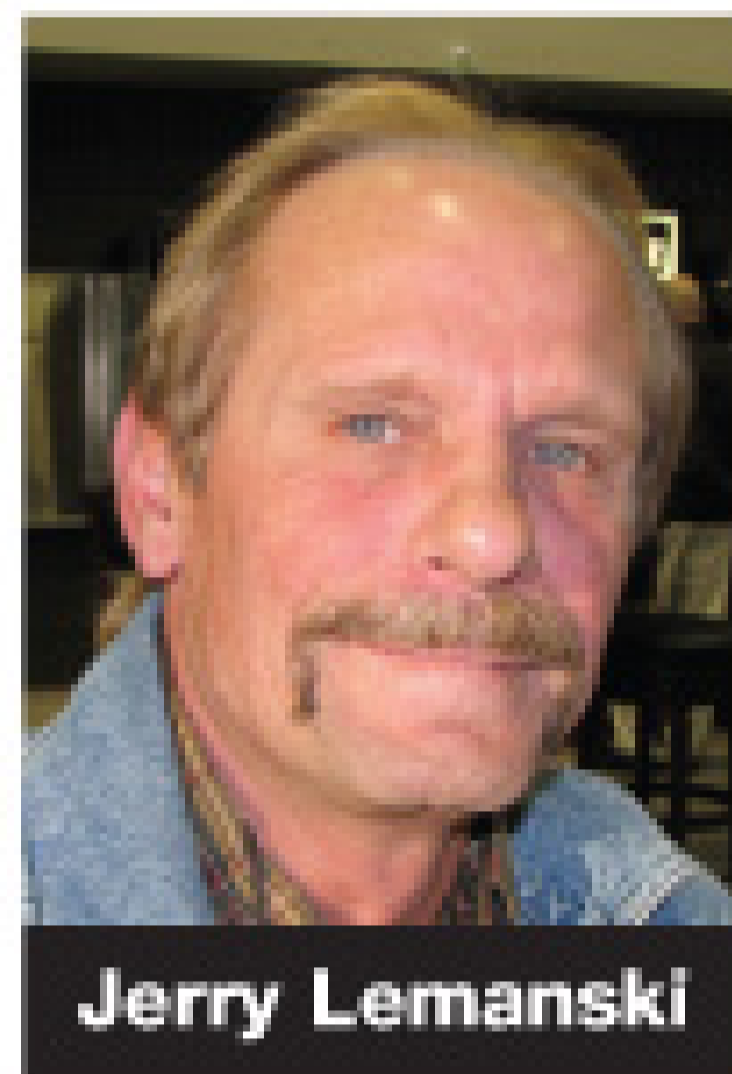

Name:
Jerry Lemanski, owner
Company:
Bay Area
Environmental
Services
Location:
Riverview, Fla.
Employees: 25
**Years in
Business:** 26

With 25 employees and 26 years in the business, Jerry Lemanski has a significant investment in his staff and the fleet that provides industrial pumping to factories across Tampa Bay from St. Petersburg on Florida's western coast.

"New hires don't get on the truck right away," he says. "They work as a helper, learn-

ing to operate everything. They start at the bottom and work their way up. They learn the vehicle backward and forward," coming to respect the heavy equipment and to be able to drive the truck responsibly.

Lemanski says how fast a person moves up through the ranks "is all up to the individual. Each individual is different. You can tell within a week whether someone's got the capabilities or not (to become a driver). If not, they remain a laborer."

Specifically, Bay Area laborers are groomed in proper mechanical operation of all facets of the industrial vacuum trucks, including how to keep themselves and others around them safe when in proximity to high pressure waterblasting and vacuum tools. Lemanski stresses the development of enough comfort with the equipment to foster confidence without allowing the operator to slide into dangerous complacency.

"They learn every aspect from the mechanics to the operation to the maintenance, from the back end all the way to the front, before they ever get in that cab," he says. This includes servicing, greasing, changing bearing packings, setting and cleaning the inspection cameras daily. Then, once a technician has gained driver status, each one goes through a daily pre-route vehicle routine that includes checking oil, water, air in the tires, "anything that has to do with good performance and safe operation of that truck," according to Lemanski.

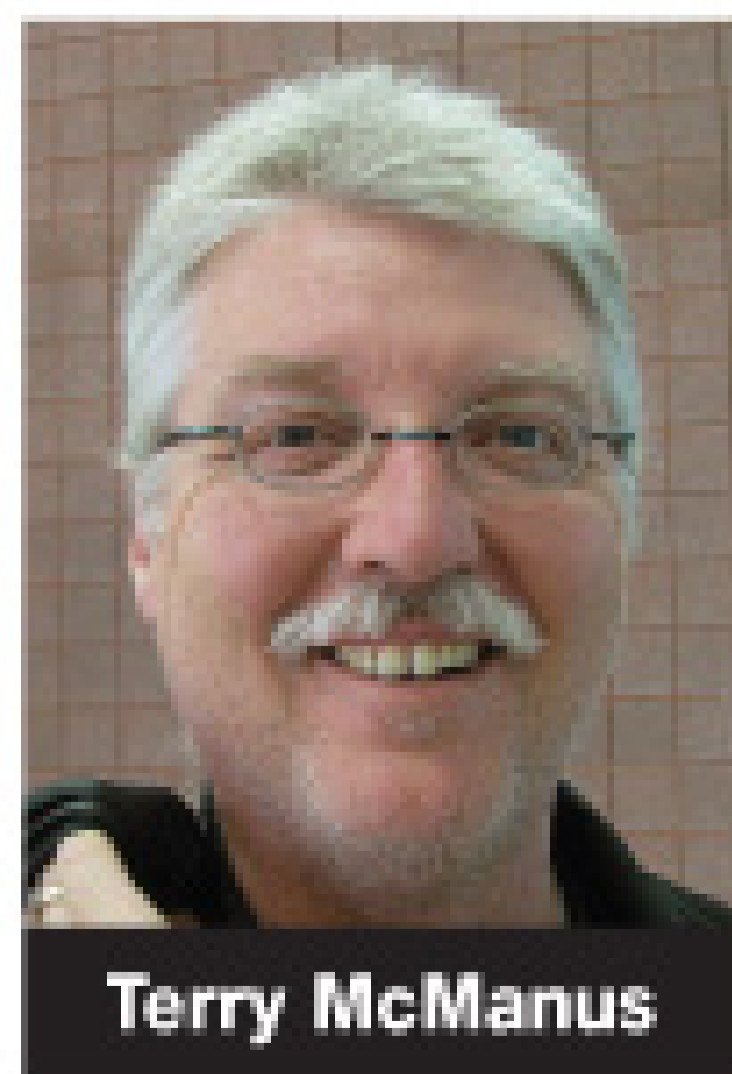

Name:
Terry McManus,
owner
Company:
Ace Septic Services
Location:
Abbotsford, B.C.,
Canada
Employees: 6
**Years in
Business:** 4

"It's hands on," says Terry McManus, describing the type of training his drivers receive. "You come out with me, and you don't solo at all until you know the ins and outs of how the pump works. There's a learning curve. I show them what the pump's capable of, the proper lubrication method, how to set things. I tell them if it's

Comments may be directed to Mary Shafer in care of Pumper. You may also e-mail pipelines@pumper.com.

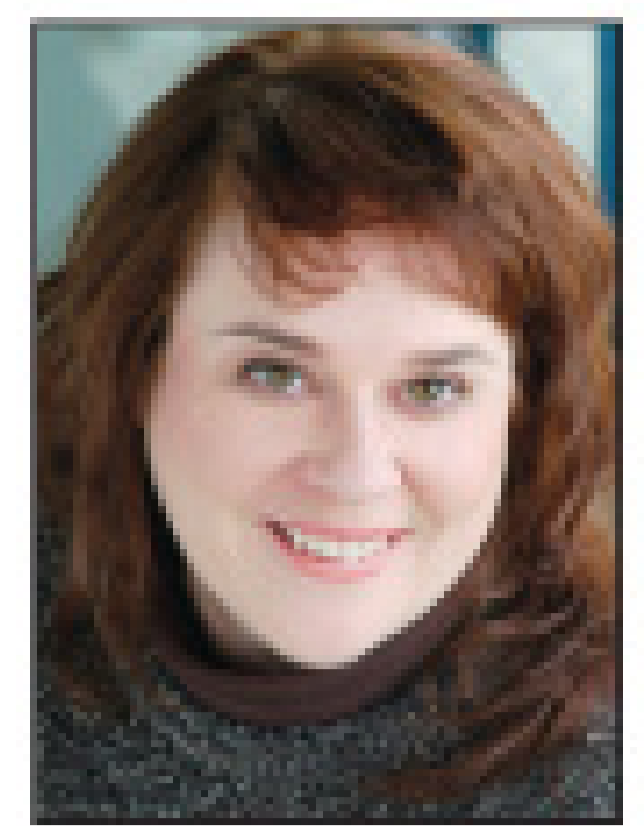

not right, don't use it, call me or get somebody in there so we can make sure (it's running properly). I stress daily maintenance, the importance of keeping everything cleaned out."

It's a training method he's perfected, McManus says. But he learned the hard way how important it is to provide thorough, one-on-one, "with-the-boss" training that creates employee appreciation for the kind of investment he makes in them and the vehicles. "I had some who didn't, and they're not here anymore. They blew up one pump, and that was enough for me. It was just absolute neglect."

Another lesson learned the hard way was to make sure that smaller equipment also represents a real investment. "Unfortunately, when we were first in the business, we bought cheap hoses, and had a lot of kinking issues," recalls McManus. He says it's hard to impress upon employees the need to treat equipment with respect when it's clearly substandard to begin with. "We've since replaced all those, and it's working out much better," he says.

Ace's other main training effort is around safety. "All my drivers are safety trained, for themselves and for the truck," McManus says. "We cover brake safety — I'm a stickler on brakes — making sure you've got all the fluid levels up, that the tire pressures are good, light systems. Make sure all your valves are capped and closed, otherwise you're going to spray the car behind you and they're not going to be a happy camper. This stuff is also covered in driver mechanical training, so by the time I get them for safety, it's more review and they've got it all down."

McManus plans to train future drivers first as "swampers" — riding shotgun with an experienced driver — since that's how he trained his latest driver, and it has worked out well. "He was doing the labor, running the hoses and the pump. He got a really good mix of how the job is done, how to keep the customer happy, and the safety. I told him, 'I want you to learn all this now, because when you get to be a driver, this will be your responsibility.'"



Name:
Frank King, owner
Company:
Action King Services
Location:
Lowell, Mass.
Employees: 12
**Years in
Business:** 40

"Our portable restroom drivers first view safety videos, then we put them on a route with another driver as an assistant for two to four weeks," says Frank King, whose firm does septic pumping, line jetting and inspection and portable restrooms. "Usually that's an entry level position that doesn't require a commercial driver's license. As we

watch (the new hire) and find they're a keeper, we want them to get their CDL. Let's say they've got one day a week that's not on a route, they go and work with the septic pumpers or the jetting crew. We encourage them to get out the registry books then go down and get their permit. If they do, it's an automatic pay increase. We encourage them from that point to ride with other drivers and get their full CDL. Once they do that, when a vacancy occurs, they're the one to move into that position."

King says it's difficult to get drivers to pay attention to the kind of regular maintenance that needs to be done to take care of the truck. Basic fluid checks, tire pressure and general road safety checks are part of the pre-route daily inspection, which is also for the driver's safety. Major vehicle inspections are done during regular quarterly lubrication and other scheduled work that's done by an outside mechanic. ■



Michigan Vacuum Trucks

Show Specials:

2007 Freightliner M2

19,000.00 miles

250 h.p. Cat

NEW 2500 Gallon Vacuum Unit

Masport 400

\$67,000

Show Specials:

2003 Freightliner FL70

225 h.p. Cat

156,000 miles

NEW 2500 Gallon vacuum unit

Masport 400

\$45,000



**All trucks are equipped with Masport Pumps
1/4" Steel Construction**

**Custom Built Tanks
to Your Specs!**

P.O. Box 234 Carleton, MI 48117

E-mail: mvtinc@centurytel.net

**Masport
NVE**

Call for a FREE quote today!

734.777.0390

*Prices are subject to change.



KMH EQUIPMENT COMPANY

SALES • RENTALS • SERVICE

Indianapolis, Indiana
Marietta, Ohio



VacAll AllJetVac



Presvac DOT 407/412



VacAll AllVac AVR B

AVAILABLE FOR SALE, RENT OR LEASE/PURCHASE

1-888-564-0202

www.kmhequip.com

435 GALLON VACUUM TANK



- 1/4" Aluminum Construction
 - Conde Super 6 Pressure Vac Pump with 5.5 hp Honda Electric Start
 - 12 Volt Water Pump
 - 300 Waste/135 Fresh
 - 25' Hose and Wand
 - 2" Sight Eyes in Waste
 - Sight Tube on Fresh Water
 - Completely Self-Contained
 - Ready to Work
- *OTHER SIZES AVAILABLE***

Robinson Septic Service Inc.

125 Rockrimmon Dr., Bellefonte, PA 16823 • t: 814.353.0263 • email: honeydippers@aol.com
1.800.252.3848 • www.robinsonsepticsservice.com



Money Talks...

and you should too. Tell your customers about **Pro-Sept**, a new warranty program exclusively for residential septic systems.

Word of mouth can earn you money!

Just refer your customers to us, and every warranty written as a result, earns you cash. It's that simple!

Pro-Sept offers customers:

- Up to \$25,000 for septic repair or replacement
- \$500 deductible
- 3 or 5 year term
- Transferrable to new homeowner if home is sold.

Call us TODAY to get started.

Pro-sept™ Septic System Protection Plan
888.999.5208

353 Candlewood Lake Rd., Brookfield, CT 06804 • www.powderhornagency.com



TUF-TITE®



Thanks for visiting us!

For Samples & Pricing
Call: 800-382-7009

Septic Tank Riser, Lid & Safety Pan™

FREE FREIGHT ON FULL CARTONS!

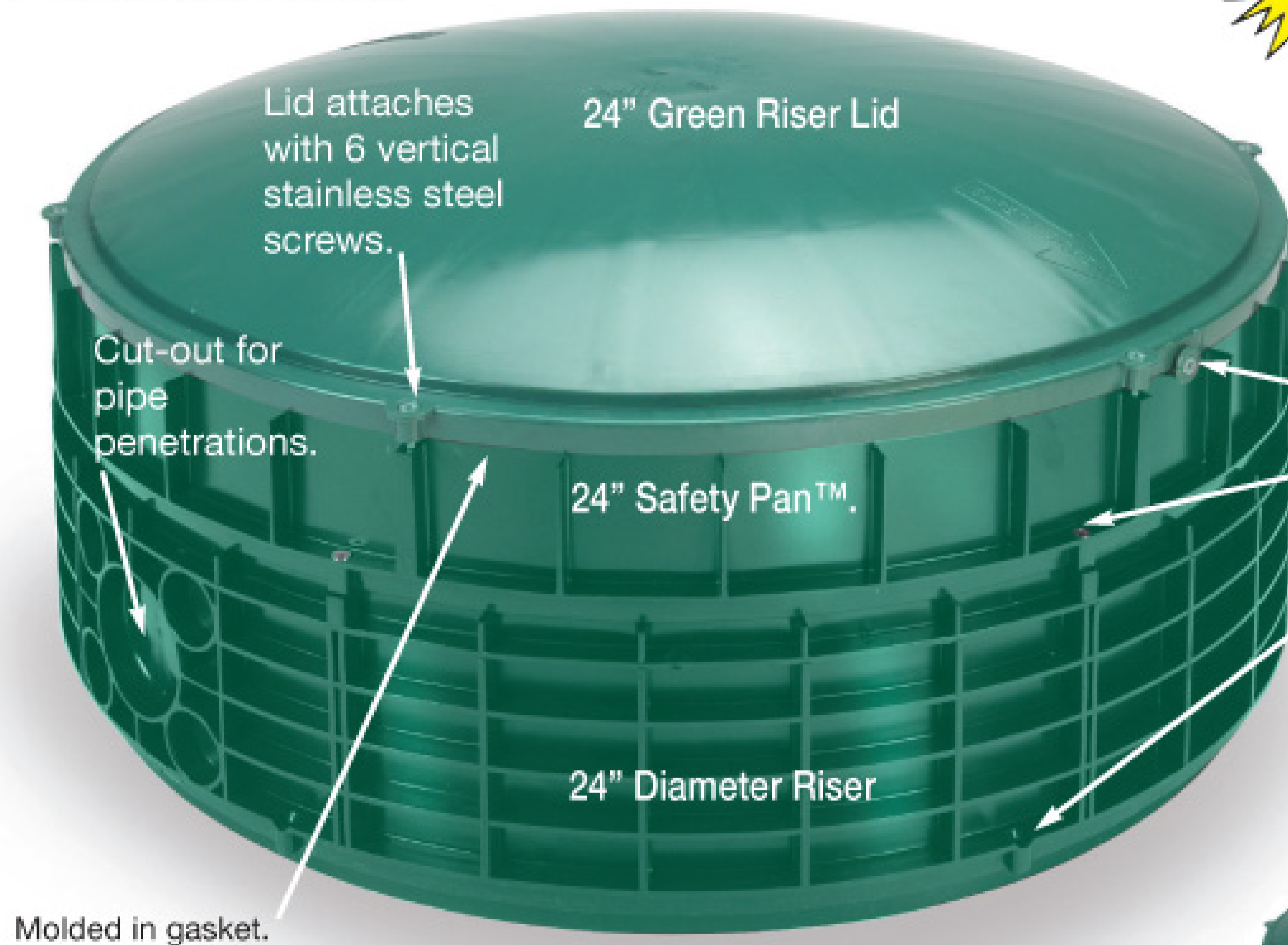

Available in 12", 16", 20" and 24" diameters.

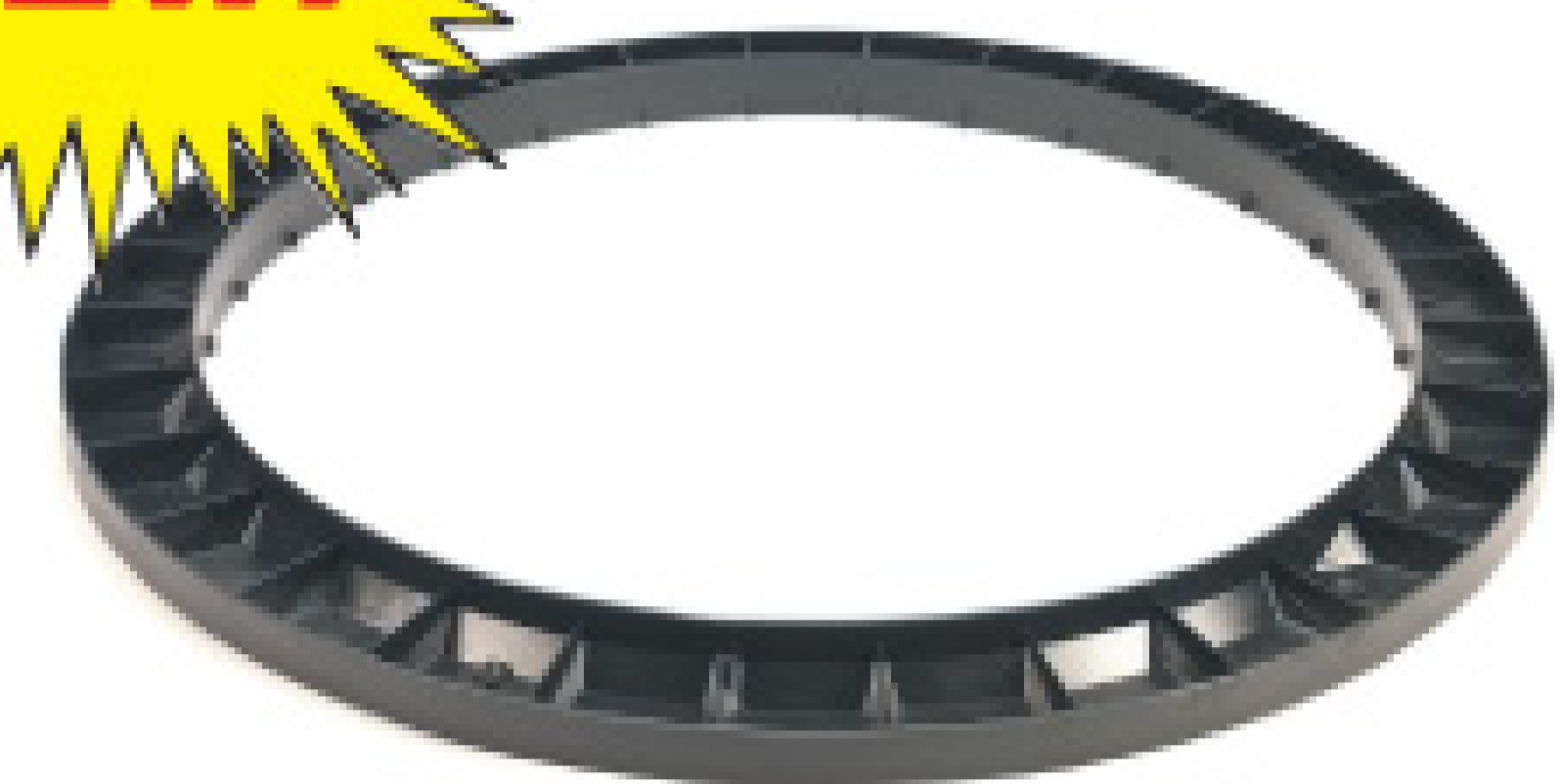

Tank Adapter Ring

New - Horizontal Safety Screw.

Safety Pan™ to Riser attachment with 6 vertical stainless steel screws.

Riser to Riser attachment with 6 vertical stainless steel screws.

Patent Numbers
5,617,679 &
5,852,901; other
pats. pending.

Riser Lid

with Molded-in gasket.
Available in 12", 16", 20" and 24" diameters.

Concrete Lid w/handle

Safety Pan™

Safety Pan™ available in 16", 20" and 24" diameters.

Riser

For septic tanks. Stackable in 6" increments. Available in 12", 16", 20" and 24" diameters.

Tank Adapter Ring

For mounting riser flush to top of tank when casting-in is not an option.

Effluent Filters

Patent Numbers
6,319,403; D 431,629; other
pats. pending.

800 GPD
ANSI/NSF
Standard 46

4" Sch. 40 & SDR-35

EF-4
4" Filter

1500 GPD
ANSI/NSF
Standard 46

4" Sch. 40 & SDR-35

244 ft. of
1/16" filtration
area.

EF-6
6" Filter

Gas/Solids
Deflector

One-Piece Tank Seal

For concrete Septic tanks and D-boxes. Accepts pipes from 1-1/2" to 4". Mounts with or without concrete flash.



TS-4-RUBBER TANK SEAL
(will hold 10psi)
TS-4PRO TANK SEAL
(will hold 5" vacuum)

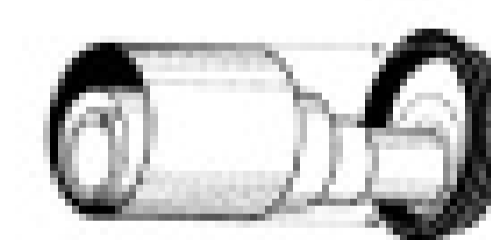

Free Freight: 32¢

Patent No's
4,951,914,
5,624,123
& 5,711,536;

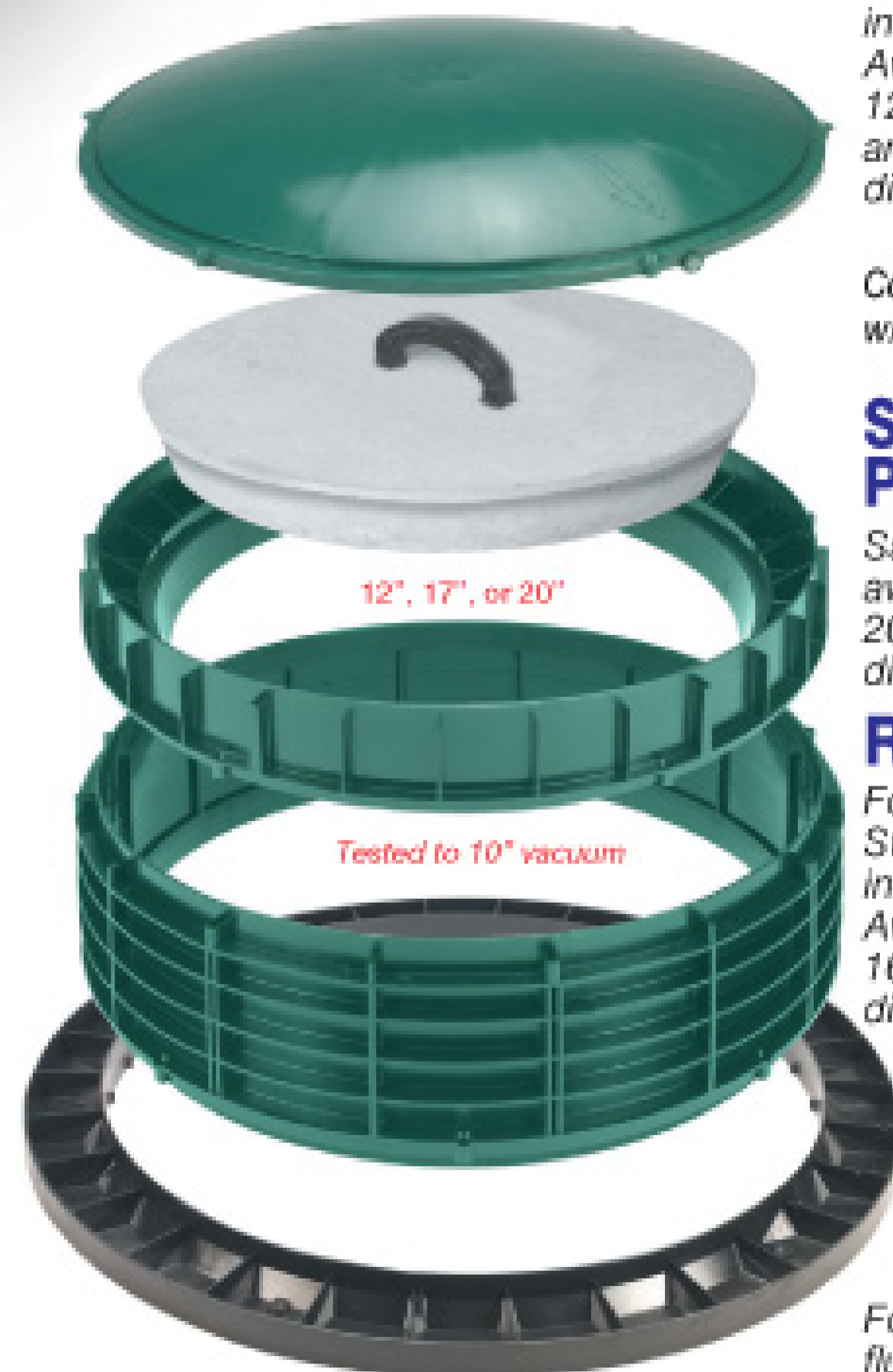

Tuf-Tite®, Inc. • 500 Capital Drive • Lake Zurich, IL 60047
800-382-7009 • 847-550-1011 • (fax) 847-550-8004 • www.tuf-tite.com
Plastic... Our Business, Not Our Hobby™





We pay attention to the details.

- Fabricated to the best industry standards using the highest quality products available
- Custom configurations to your specifications
- VISA, American Express, MasterCard, & Discover
- Fast, same day shipping, low freight rates



**ATLANTA
RUBBER &
HYDRAULICS**

1640 D Sands Place, Marietta, GA 30067
Toll Free: 800.282.6272 • Phone: 770.955.5225
Fax: 770.955.2377 • e-mail: sales@atlantarubber.com

Call Atlanta Rubber
at
678.385.9645
for
2009 catalog
on
hoses and fittings.

CLEAR COMPUTING *with* INSIGHT Total Activity Control Street Eagle GPS



GREEN MACHINE

- Bulk Email Invoicing
- On-Line Bill Payment

Increase Profits • Cut Costs • Improve Productivity

- Work Orders with Annotated Map
- Calendar Dispatch
- In-Vehicle Garmin
- TACTrackerPRO
- Your Company, Your Way, Anywhere, Anytime

21 YEARS OF
INDUSTRY
LEADERSHIP
1988 - 2009



- Lease or Buy
- FREE Trial

Clear Computing
(888) 332-5327
www.clearcomputing.com

Insight USA
(301) 866-1990 x201
www.mds-inc.com



12 VOLT DC HIGH HEAD WASHDOWN PUMP

- 1 HP Washdown Duty Motor for Severe Operating Conditions
- Investment Cast 316 Stainless Steel, Cast Iron or Cast Bronze Construction
- All Models Equipped With High Efficiency Stainless Steel Impeller
- Discharge Port Rotates in 90° Increments
- Four Front Drain Plugs
- Maximum Flow 56 GPM
- Maximum Head 80 Ft. (35 PSI)
- Maximum Temperature 200° F



The AMT 12 Volt DC Washdown Pumps are designed for pumper, septic service, OEM, and marine applications requiring a DC motor. The motor has a one hour duty rating and is furnished with a grade 303 stainless steel shaft. Washdown Duty Pumps are available in a variety of construction and seal materials to meet your specifications. Pull-from-the-rear design for easy servicing without disturbing piping.

Call us toll free at 888-268-7867 or visit our website
www.amtpump.com for more information.

American Machine & Tool
A Subsidiary of The Gorman-Rupp Company
400 Spring Street
Royersford, PA 19468



2008 Kenworth T3 Series

Aluminum Cab - Non CDL - 22,000 G.V.W.
 8,000 lb front axle -14,000 lb rear axle
 Paccar (Cummins) Diesel
 Turbo exhaust brake
 Allison auto transmission
 19" Wheels

\$73,975



So much more...
 Power door locks
 AM/FM stereo
 Cruise control
 160 amp alt.
 Air suspension seat
 R.H. electric window
 Peeper window in door
 Stainless steel door hinges

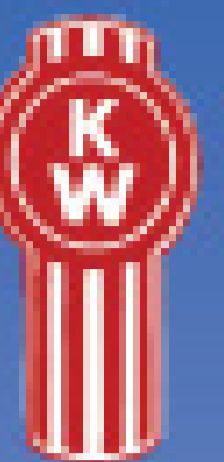

**1700 Gallon Aluminum Tank
 (400 water / 1300 waste)**

Low style work station on drivers side,
 bucket holders, Masport HXL4 vacuum
 pump, remote controls, unit hauler. Burks
 DC 10 wash down system with timer and bypass,
 spring rewind reel, large cabinets... *all the features.*

2008 Kenworth T3: \$38,900
Tank / Pumping System: \$35,075
Sale Price: \$73,975



F.O.B. Kansas City

Monthly Lease: \$1,157

Combination Septic & Restroom Service

2009 International 4300 Series M7

Automatic Transmission, air brakes, aluminum wheels,
 chrome bumper, fancy factory paint...loaded

2000 Gallon

2 Compartment - 500 Fresh/1500 waste
 Masport HXL75, Burks DC10 washdown, unit hauler, rear manway
 & full length hose trays.

\$84,250 As Low As \$1670 mo.



*Slide-In Pump Skids
 Custom built to your specs
 Call to get our low price!*



2007 Chevrolet 7500 'Old Emission'

200 HP 7.8 liter, auto. trans, air brakes, AC.
2000 Gallon 1500 Waste/500 Fresh
 Masport HXL4, Burks DC-10
 Hot Shift P.T.O
Dual Service

2008 Hino Model 338 - 33,000 GVW

260 HP 6 spd. trans. ,air brakes
2500 Gallon Septic
 Masport HXL15,
 350 CFM
 pumping system.



\$82,150
 F.O.B. Kansas City
 Lease from **\$1579** mo.



\$73,275 As Low As \$1222 mo.

KeeVac

Industries Inc.

NOT just a another broker. *Complete Sales & Service Center*
GUARANTEED CREDIT APPROVAL!
New Start Up Operators...OK!

1835 W. Union Ave., Unit 1, Sheridan, CO 80110



Kevin Keegan
 33 Years Experience

Call Kevin. Call Matt. ...**Just Call KeeVac**

866-789-9440

www.keevac.com

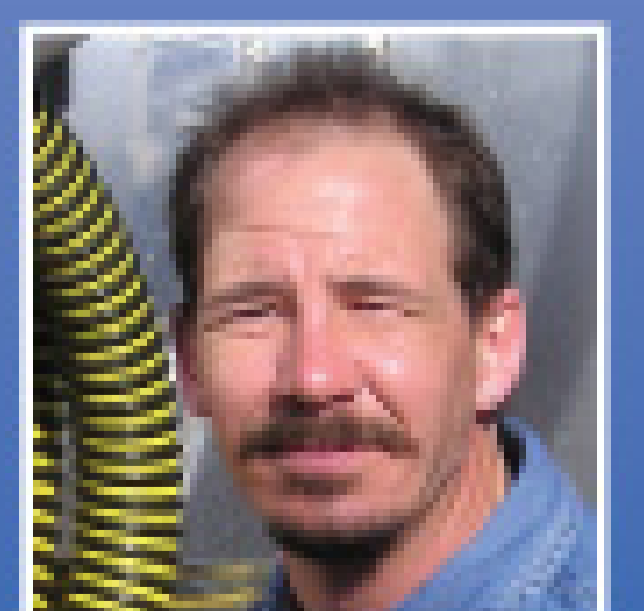

Matt Crowell
 19 Years Experience

Wells Cargo COG is Revolutionizing the Portable Sanitation Industry . . . **AGAIN!**



The ALL New Modular Product Line

- Hydraulic lowering system: no steps, platforms or railings
- Toilet, shower, combinations, and custom floorplans available
- Able to ship by container and crane/helicopter lift compatible
- Vacuum pump system allows for direct sewer connection
- Reduced fresh water demand and low maintenance requirements



20' Unit features 10 private unisex restrooms and external hand washing station. "Self-Pumping" up to 300 yards.



Wells Cargo COG
Effective Solutions. Uncompromising Quality.
Booth: #14043
Phone: (888) 574-4222
Web: www.wellscargoCOG.com

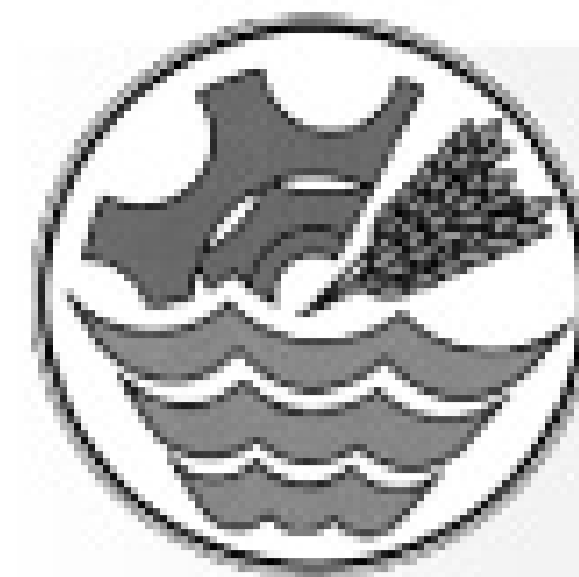

Tanks For Your Business

Mid-State Tank manufactures stainless steel and aluminum tanks and has become a well-known and respected supplier for the agricultural, aviation, industrial and fire services, as well as pressure/vacuum tanks.

Mid-State Tank holds an ASME stamp and is D.O.T. approved.



Mid-State Tank Co., Inc.

PO Box 317 • Sullivan, IL 61951
(800) 722-8384 • Fax: (217) 728-8384
www.midstatetank.com



Steel Tanks



Polished Aluminum Skirting and Tool Boxes

• 2009 Dodge 5500, Cummins Diesel, Automatic,
19,500 GVW, 1000 Waste, 300 Fresh

.....New 4x2 \$62,500
.....New 4x4 \$65,500

• 2008 GMC 5500, Duramax Diesel, Allison Automatic,
19,500 GVW, 1000 Waste, 300 Fresh

.....New \$59,000

• 2007 GMC 5500, Duramax Diesel, Allison Automatic,
19,500 GVW, 1000 Waste, 300 Fresh, Miles in 40,000

4 Trucks Available\$48,000 each



8 RESTROOM | 10 RESTROOM | 12 RESTROOM | 14 RESTROOM | 16 RESTROOM | 20 RESTROOM

SLIDE-IN UNITS & USED TRUCKS AVAILABLE / MASPORT, JUROP & CONDE VACUUM PUMPS

CHECK OUR PRICES

LANE'S VACUUM TANK, INC.

3133 VANZORA RD. • BENTON, KY 42025

800.592.3308 • 270.527.9945

RODNEY LANE'S CELL 270.832.3793



Aluminum Tanks



by Amthor 5/16" Thick

• 2009 Dodge 5500, Cummins Diesel, Automatic,
19,500 GVW, 1000 Waste, 400 Fresh

.....New 4x2 \$71,500
.....New 4x4 \$74,500

• 2008 GMC 5500, Duramax Diesel, Allison Automatic,
19,500 GVW, 1000 Waste, 400 Fresh

.....New \$68,000

• All Brand Trucks Available

• New Septic Trucks Available

• Used Septic and Toilet Trucks Available

Trailer Mount Slide-in Tank

600 gallons waste/200 gallons fresh water.

\$13,000



DuraBlade™ Vane Pump Blades

How Pumps Save Money

Longer run-times between pump maintenance means cost savings and increased productivity for you. Make it happen with DuraBlade™ high-performance pump blades.

Superior Design, Precision Manufacturing

- Improved wear resistance
- Increased dimensional stability
- Reduced warpage
- Less friction for cooler-running pumps

- ✓ Fabricated to exact tolerances
- ✓ Phenolic laminate material
- ✓ Specially heat treated



Thanks for visiting us!



811 Industrial Loop
P.O. Box 311
Breckenridge, TX 76424
Toll-free: 1-800-272-7557

Engineered products and materials for pumps and compressors

Another high-quality, engineered laminate from Norplex-Micarta.
DuraBlade is a mark of Cook Compression.

SmithCo

SIDE-DUMP TRAILERS

SIDE DUMP

Call **800-779-8099**

www.sidedump.com

30902 C38
Le Mars, Iowa 51031



CP-20 Offroad



SHV Series



DT Series



MHV Series



S Series

Manure, Slurry, Sludge, Green Waste, Food Residuals, Compost, SmithCo Hauls it All.

Stock Pile, Spread, Stability, Selection, Service...SmithCo

Just Say No to Garbage Disposers

The Answer Man's simple advice to homeowners and onsite maintenance pros: "Do not deposit anything into the septic tank unless you have eaten it first!"

By Roger E. Machmeier, Ph.D.

Q We are purchasing a house with a new 1,500-gallon septic tank. As part of the home inspection, our inspector gave us the rundown on septic tanks. On the topic of our garbage disposer, he rightly recommends against using it for anything other than very light duty. But he went on to further stress never put onions or cabbage down the disposer, as it will (somehow) harm the ecology of the septic system. My wife and I have been scratching our heads as to how/why this could be. Do you have any insights? Also, any tips on when/how to use a diverter valve installed between the main tank and the leachfield?

A I have never heard the onion or cabbage story in regard to affecting the bacterial action in a septic tank. I can't imagine what impact either cabbage or onions might have. Any raw vegetables will not break down completely and so will accumulate more solids in the septic tank. I see no reason why the bacterial action should be adversely affected.

AVOID CABBAGE

Your story is interesting because my wife and I recently had an experience with a plugged garbage disposer. We moved to a new home with a garbage disposer. We were disposing of cabbage leaves when the unit became badly plugged.

The serviceman who

cleaned out the disposer and waste piping stressed that cabbage should not be placed in the disposer. He also included onion skins, celery and banana peels as items to keep out of the disposer.

So, I do know onions and cabbage can plug a garbage disposer. Perhaps this is the problem your inspector was referring to rather than in the septic tank.

Grinding bones or other materials that will not decompose with bacterial action will also add solids to the septic tank sludge layer. Other items that should not be added to a septic tank, with or without a garbage disposer, are cooking fats and coffee grounds.

SIMPLE ADVICE

Any organic material that has not been through the human digestive system will fail to break down in the septic tank. This is why using a garbage disposer is not recommended with a septic system. We used to present this message at our Onsite Sewage Treatment Workshops in Minnesota: "Do not deposit anything into the septic tank unless you have eaten it first!" We did exempt toilet paper from the list.

The frequency of cleaning the septic tank will be increased with the use of a garbage disposer. The quality of the effluent going out of the tank will not be as good. This is because the organic materials have not been through the human digestive system and do not decompose as much in the septic tank.

I would also recommend a filter be installed in the outlet tee

The portion of the drainfield that no longer receives effluent from the septic tank will dry out and oxygen will enter through the soil pores. The biomat will be oxidized as will some of the fine sewage solids. If the resting time is adequate, the drainfield will likely recover most or all of its initial treatment capacity.

of your septic tank. This is especially important when a garbage disposer is being used. The outlet filter will prevent large solids from leaving the septic tank and getting into the drainfield. Some onsite codes now require septic tanks to have outlet filters.

DIVERTER VALVE

In regard to your question on using the diverter valve, I would assume the valve has been installed to use only half of the drainfield while the other half is not being used. I believe it is sound design to divide the drainfield and use one part while the other part is resting and recovering treatment capacity.

The designer and/or installer of the onsite sewage treatment system should have made recommendations on how to use the diverter valve in your system. Your inspector also may have some suggestions on the operation of the diverter valve.

In general, I would suggest a diverter valve be switched at least on an annual basis. There are some other considerations depending on the size of the drainfield. Also, the drainfield could be a series of drainfield trenches or two seepage beds.

If the drainfield has trenches and if there is an inspection pipe

at the end of each drainfield trench line, a pumping professional can quickly determine how much of the drainfield is being used. If the drainfield trenches are on a slope and sequential distribution is used, it will only be necessary to check the effluent level in the last trench.

It would be a good idea to have each of the trenches checked at least once to see if effluent was reaching the end of the trench. If all the trenches on one side of the drainfield become full before the end of a year, then the diverter valve should be switched to allow half of the field to rest.

The portion of the drainfield that no longer receives effluent from the septic tank will dry out and oxygen will enter through the soil pores. The biomat will be oxidized as will some of the fine sewage solids. If the resting time is adequate, the drainfield will likely recover most or all of its initial treatment capacity.

The same procedure should be followed with the other half of the drainfield, which is being used. Once a time period or frequency has been established for switching the diverter valve, frequent use of the inspection pipes should not be necessary. ■

Readers are welcome to submit questions to the Answer Man. Send your question to COLE Publishing by e-mail to editor@pumper.com, by fax to 715/546-3786; or by mail to P.O. Box 220, Three Lakes, WI 54562. We will pass your question along to Dr. Machmeier.



Packaging Made Perfect!

- Industry Leading Design and Fabrication
- Dependable High Performance Vacuum Pumps and High Vacuum Blowers
- Complete, Easy to install
- Reduce your Engineering and Installation Time
- Save Time and Money - Increase Profits!



Blower Packages



Challenger™ Packages

Diesel Engine Hydraulic Drive Packages with Cat Hi Pressure Pump

NVE

National Vacuum Equipment

800-253-5500

www.natvac.com

SAVE FREIGHT COSTS with our NEW Fayetteville Arkansas distribution center!



Designed and Built in Michigan by the Leaders in Engineering and Innovation!

NVE National Vacuum Equipment, Inc.
801 Northfield Dr., Troy, MI 48068
Phone: 800-253-5500 Fax: 248-270-1100
Environmental Expo 2009

By Vendor
1 of 1 EN-EXP2.1.016-000

Hull's Truck Bodies

459 Joe Shoemaker Rd. | Minford, OH 45653

Vacuum Trucks built to order, any size or make, delivery to all 50 states. Quick turn around time.



Phone: 877.898.5104

E-mail: hullstruckbodies@yahoo.com

Webpage: hullstruckbodies.com

RouteOptix Inc.

Customer Service
Optimized Routing
Visual Dispatch
Asset Management
Disposal Tracking
Customer Billing

THANKS FOR VISITING US!

PRIMER & CLEANERS ENVIRONMENTAL EXPOS INTERNATIONAL

A Complete Software Solution

(866) 926-7849

www.routeoptix.com

info@routeoptix.com

Kanaflex® 220RS Rubber All-Weather Suction Hose

SUPER FLEXIBLE IN COLD WEATHER

Call for Low Prices on 100' Lengths & Coupled Hose Assemblies

A revolutionary new method of manufacturing rubber suction and discharge hose has drastically reduced costs to hose users. The new process, ten years in development, utilizes Kanaflex SBR TYPE "T" POLYMER to give the lightweight, rubber hose outstanding flexibility and long life.

New Series 220 rubber suction and discharge hose has excellent dimensional stability and is easy to couple. Manufactured in six sizes from 1-1/2" through 6", the hose is available in 100' lengths. I.D. and O.D. are smooth. Temperature range is -40° F to 160° F – ideal for industry and construction job site use.

Distributors of: Dunlop • Goodyear • Kanaflex • Plastiflex Hi-Vac & Other Hose • P-T & Evertite Quickcouplers Dixon & Le-Hi Couplings • Hose Clamps • Banding Equip.

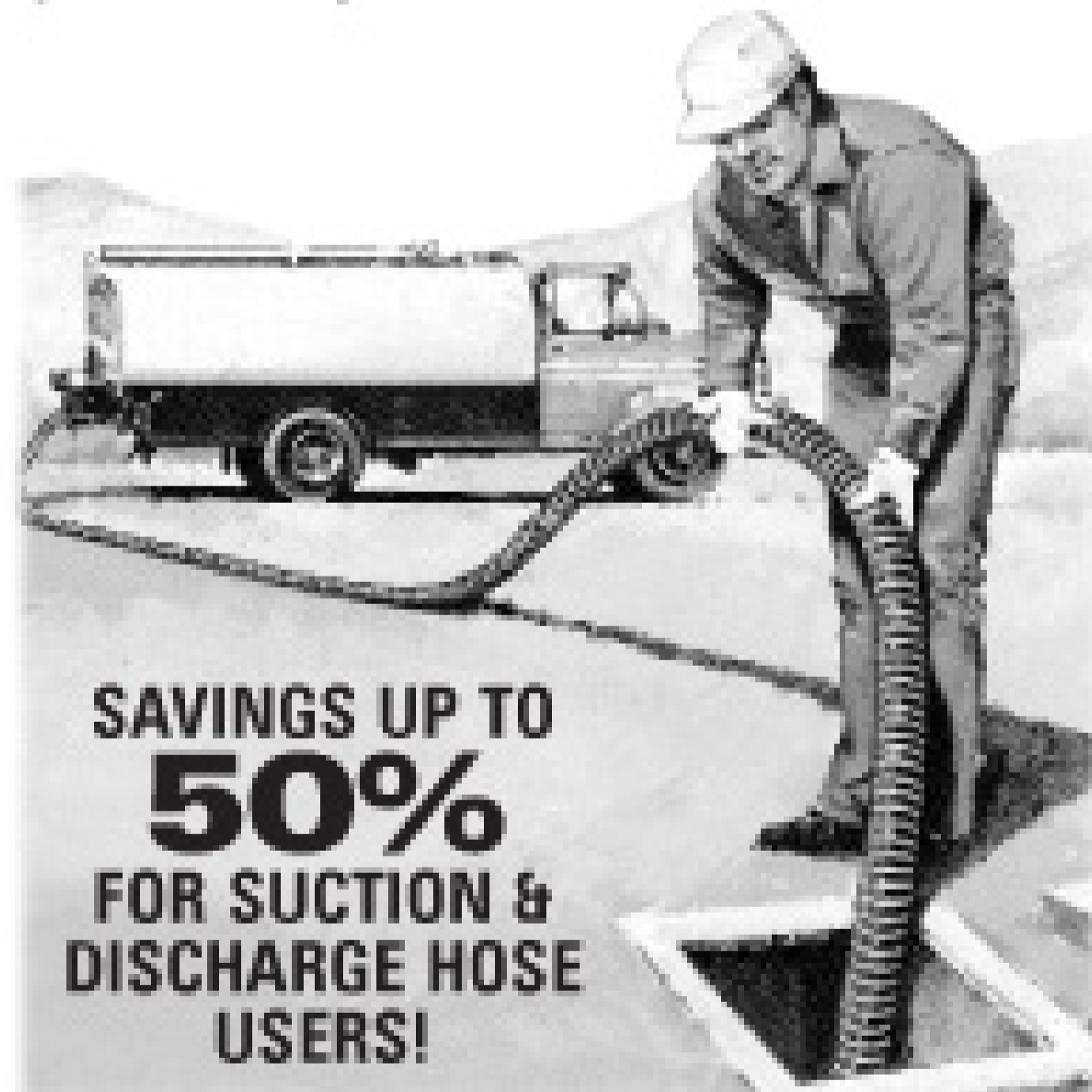

SAVINGS UP TO
50%
FOR SUCTION &
DISCHARGE HOSE
USERS!

MRP

Milwaukee Rubber Products, Inc.

Toll-Free
1.800.325.3730

www.milwaukeeerubber.com

FAX: 262.781.1742

MAILING ADDRESS: P.O. Box 451 • Butler, WI 53007

WAREHOUSE: N52 W13319 Falls Creek Ct. • Menomonee Falls, WI 53051



"DON'T BE EMBARRASSED AGAIN!"
HOW AWFUL...

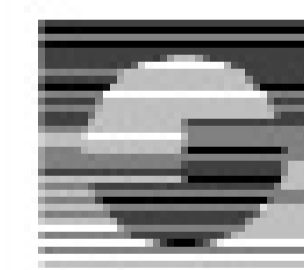

800-622-8768

sweetair.com

SWEET SEPTIC SYSTEMS, INC.

5701 Mother Lode Drive • Placerville, CA 95667

Fax: 530-622-1087

SWEET AIR™ FILTERING DEVICE

PAT PENDING

UPC Approved

HOW WONDERFUL...



Rich Restrooms

Manufacturer of Portable Restroom Trailers

- Large Capacity Poly Waste Tanks
- Water/Rot Resistant Aluminum and Steel Construction
- Indestructible Fiberglass Reinforced Polymer Laminated Floors
- Industrial Powder Coated I-beam Framing
- Construction Grade and Luxury Floor plans
- Rubber Wrapped floor coverings
- Premium- Easy Set up Steps

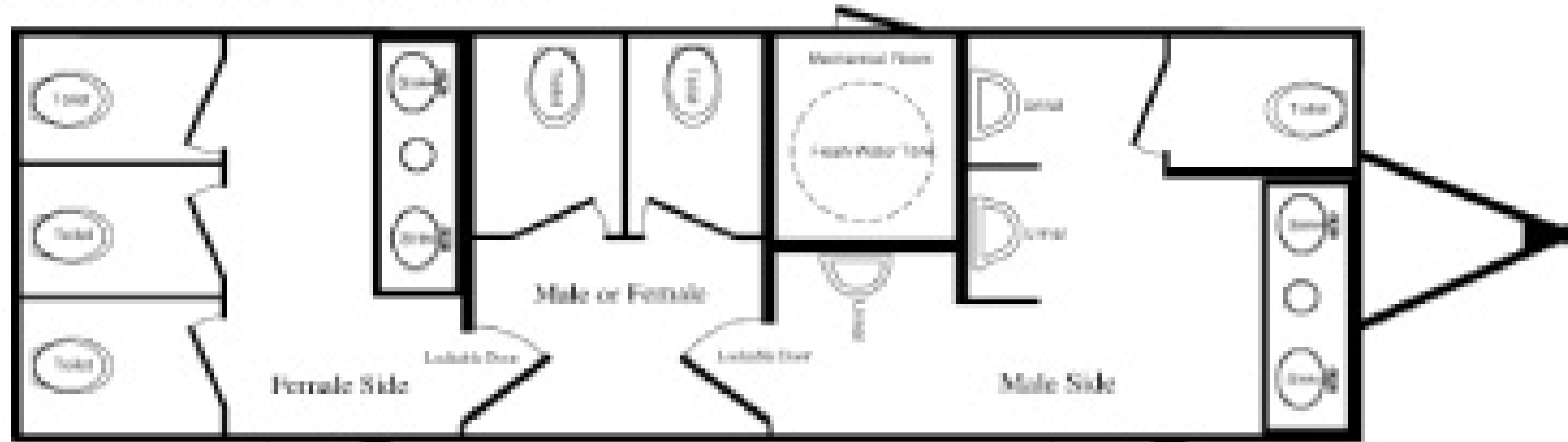

Rich Restrooms

423 S. Main St. • Topeka, IN 46571
260-593-2279
www.RichRestrooms.com



Breathe Easier... ...Live Greener



Eco Friendly Odor Control Products For
 Plumbing, Wastewater And Ventilation Systems



www.StopSepticOdor.com

www.IndustrialOdorControl.com

866-NO-STINK 973-846-7817



Simple Solutions
 DISTRIBUTING LLC
 MAKERS OF
Wolverine Brand™
 ODOR CONTROL PRODUCTS
 PayPal



Has the Health Department, Landlord or City complained about this?



The Outdoor Envirotub is environmentally friendly and made from 100% recycled materials. Light weight for easy movement. Stores up to 1200 pounds of grease. Non-stick plastic surface for easy cleaning and eliminates grease build up. Self closing lid to reduce odors and rain water. Built in containment, catches overflow, spills, perfect for coastal communities. Keeps trash areas clean, endorsed by property management and restaurant companies.

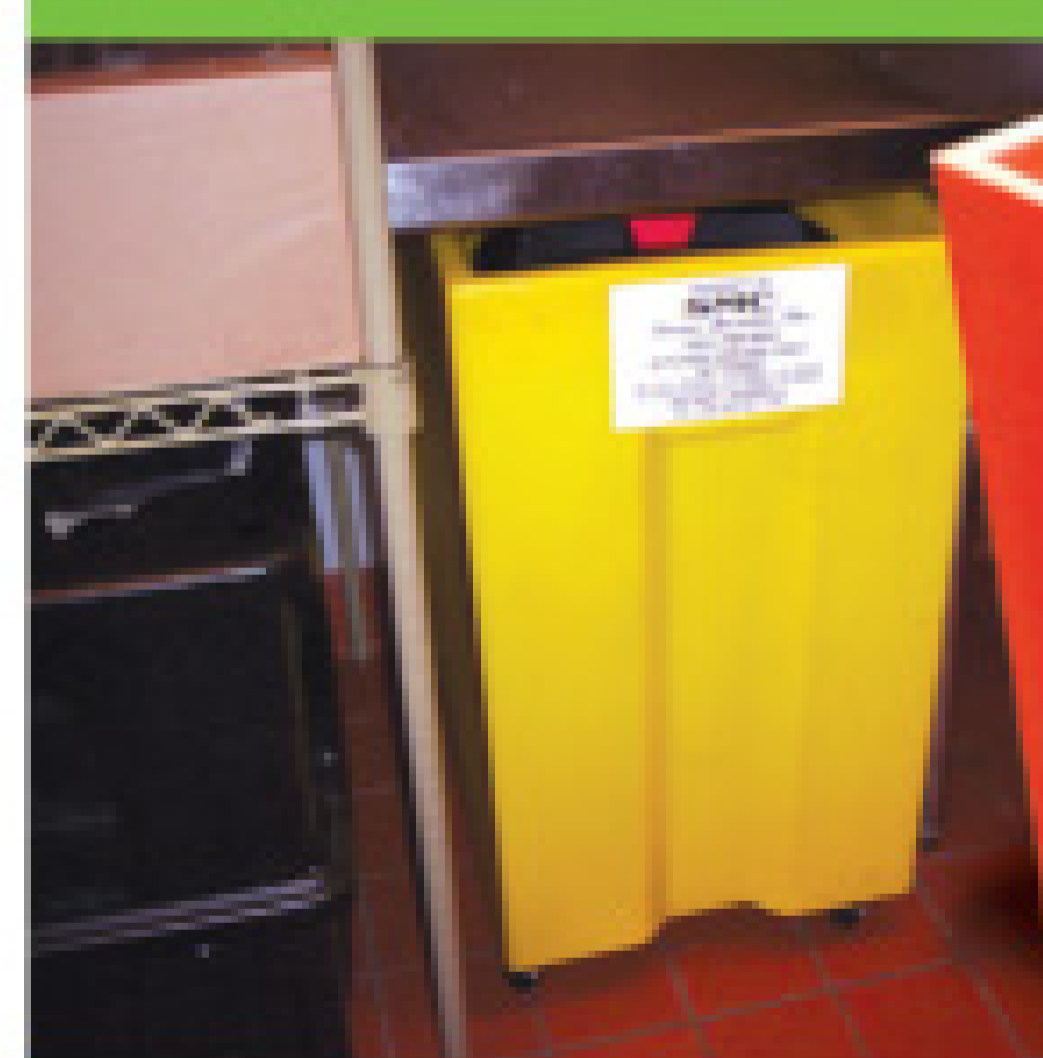

The indoor tub made to keep grease thieves away. Stores up to 55 gallons of grease. Fits under most two and three compartment sinks. Perfect for small kitchens with limited space, malls, colleges and food courts.

- > Self Closing Lid
- > 100% Recycled Plastic
- > Full Containment
- > Easily movable

ENVIROTUB

www.envirotub.com

PO BOX 1343, CORONA, CA 92878

1.866.777.4322



Plans for 2009 Advance Education and Business Opportunities

By Tom Ferrero

FRESH LEARNING OPPORTUNITIES

The grant from the U.S. Environmental Protection Agency that NAWT received to improve and implement its vacuum truck training course expired in February. We made a lot of headway toward achieving those goals, primarily by working with state associations. Most recently, the Florida Onsite Wastewater Association, or FOWA, presented the course twice in February and has funding to offer it a third time. Florida has no mandate requiring vacuum truck training, so FOWA worked with licensing authorities to qualify the course for continuing education credits. The Ohio Onsite Wastewater Association also gave the course at its annual conference this year.

NAWT held 18 vacuum truck training sessions and certified 300 operators during the last two years. It also qualified 10 individuals to teach the course. Some are pumpers running six to 10 vacuum trucks. They became trainers so their drivers would all be NAWT-certified operators.

NAWT has always believed that its training should come to a location near you. It has to be convenient and affordable. To that end, we are working on duplicating the National Environmental Health Association Inc. e-Learning online training program. NAWT courses lend themselves well to this Web-based format, which would include streaming video of all field components.

Here's how it works: Applicants would pay a fee to receive our printed instruction manual and access the e-course, then complete the work within a given time frame. Chapters from the manual end with review questions. Anyone with further questions can e-mail a NAWT instructor and receive a prompt response. A LaserGrade Test Center — each state has one or more — would administer the final exam.

Besides the convenience this solution offers, the registration fee would be about 50 percent less than a classroom course. Add travel expenses to the equation and the savings are even greater. It's a fantastic deal, and answers the many requests NAWT receives to post the courses online.

WASTE TREATMENT SYMPOSIUM

NAWT is working with the Water Environment Federation Technical Exhibition and Conference to make this year's Waste Treatment Symposium extra special. Both events are in Orlando, Fla. The symposium dates are Oct. 9-10 (Friday and Saturday), and WEFTEC follows on Oct. 11-14. For starters, registering for our symposium will include free admission to the WEFTEC exhibit hall Sunday afternoon (www.weftec.org). Last year, 1,111 vendors participated, many with information on waste treatment. Some WEFTEC vendors and participants will have the opportunity to attend our symposium, too.

Friday's agenda covers septage treatment and business planning. We're still locking down speakers, so please be patient. Saturday morning's classroom sessions focus on processing grease trap waste. Our topics are:

Trap Grease: Transforming a Liability to an Asset,

Emily Landsburg, CEO, Philadelphia Fry-o-Diesel Inc., Philadelphia, Pa.

Landsburg will talk about the challenges of processing

NAWT HAS ALWAYS BELIEVED THAT ITS TRAINING SHOULD COME TO A LOCATION NEAR YOU. IT HAS TO BE CONVENIENT AND AFFORDABLE.

sewer, grease trap and other brown greases into a biodiesel fuel that meets ASTM-D6751 (national quality standard) and lay out specific steps to implement a successful project.

Evolution of Transported Liquid Waste to Beneficial Use with Pre-Treatment Processes; Solving Regional Needs of Haulers and Wastewater Treatment Plants, *Therese Wheaton, Crystal Environmental, Springboro, Pa.*

This presentation discusses how the inability of publically owned treatment plants to meet the needs of waste haulers fueled the development of privately owned treatment works, and how recently built facilities can process greater volumes of waste with a smaller impact on them.

Biomethane Production and Utilization in North America, *Dr. Dave Parry, P.E., BCEE, CDM, Bellevue, Wash.*

Parry's talk explains how to increase biogas production in an economical, environmentally feasible, socially acceptable manner that is operator friendly. He will use authentic operating examples to present options.

Orange County (Fla.) Grease Management and Industrial User Discharge Permits, *Susanna Littell, Orange County Utilities Services Coordinator, Orlando, Fla.*

Orange County has an aggressive and successful grease trap management program partly because of its relationship with Select Processing of Orlando. Littell will discuss how that facility pretreats wastes before discharge into the municipal collection system and how the county's pretreatment program developed.

Case History of Select Processing of Orlando, *Steven Macchio, ClearFlo Technologies Inc., North Lindenhurst, N.Y.*

Macchio, owner of Select Processing of Orlando, will talk about how the facility evolved from screening and lime stabilization to dewatering and discharging effluent into the Orange County municipal collection system.

Following a Q & A session and lunch, attendees will be bused to Select Processing for a tour. The facility, an industrial user, is permitted to process 188,000 gpd of septage, grease trap waste, portable restroom wastes, and sewage sludge. It handles 30,000 to 40,000 gallons of grease trap waste a day. Class B biosolids are applied on agricultural land. Using genuine septage and grease trap waste, vendors will demonstrate operating, screening, and dewatering equipment, polymer applications, and other peripheral devices.

One interesting fact about the city of Orlando and surrounding Orange County is that they require grease traps to be pumped every 90 days. The city alone has some 10,000 restaurants, enabling many haulers to do nothing but pump grease traps.

Attendance at the symposium is limited to the number that the field site can safely accommodate, so register early by downloading the form at www.nawt.org. ■

Join NAWT Now!

Independent Member (\$150)
Company Member (\$300)
Associate Member (\$300)
State Association Member (\$100)

Be a part of the pride and professionalism that all NAWT members enjoy!

Contact NAWT today:
1-800-236-NAWT (6298) Fax 267-200-0279
www.nawt.org

Mid-Continent Truck Sales, Inc.

891 Adkins Hill Rd. • Norman, OK 73072 • 405-329-5365 • Fax: 405-329-5381 • After Hours: 405-826-4469 • www.vacuumtrucksales.com

Trucks - Trailers - Vacuum Tanks - Pumps



2001 IH 4700, DT466E, Allison auto, non-CDL, air brakes, new MEC 6500 vacuum pump, new 1100/400 vacuum tank.



2000 IH 4700, DT466E, 5-spd., non-CDL, double frame, new Wally 403HR vacuum pump, new 1600 gallon vacuum tank.



1998 Freightliner FL60, Cummins 5.9 (210 hp), 6-spd., Masport H75V vacuum pump, General 47 series triplex, 1100/200 gallon vacuum tank.

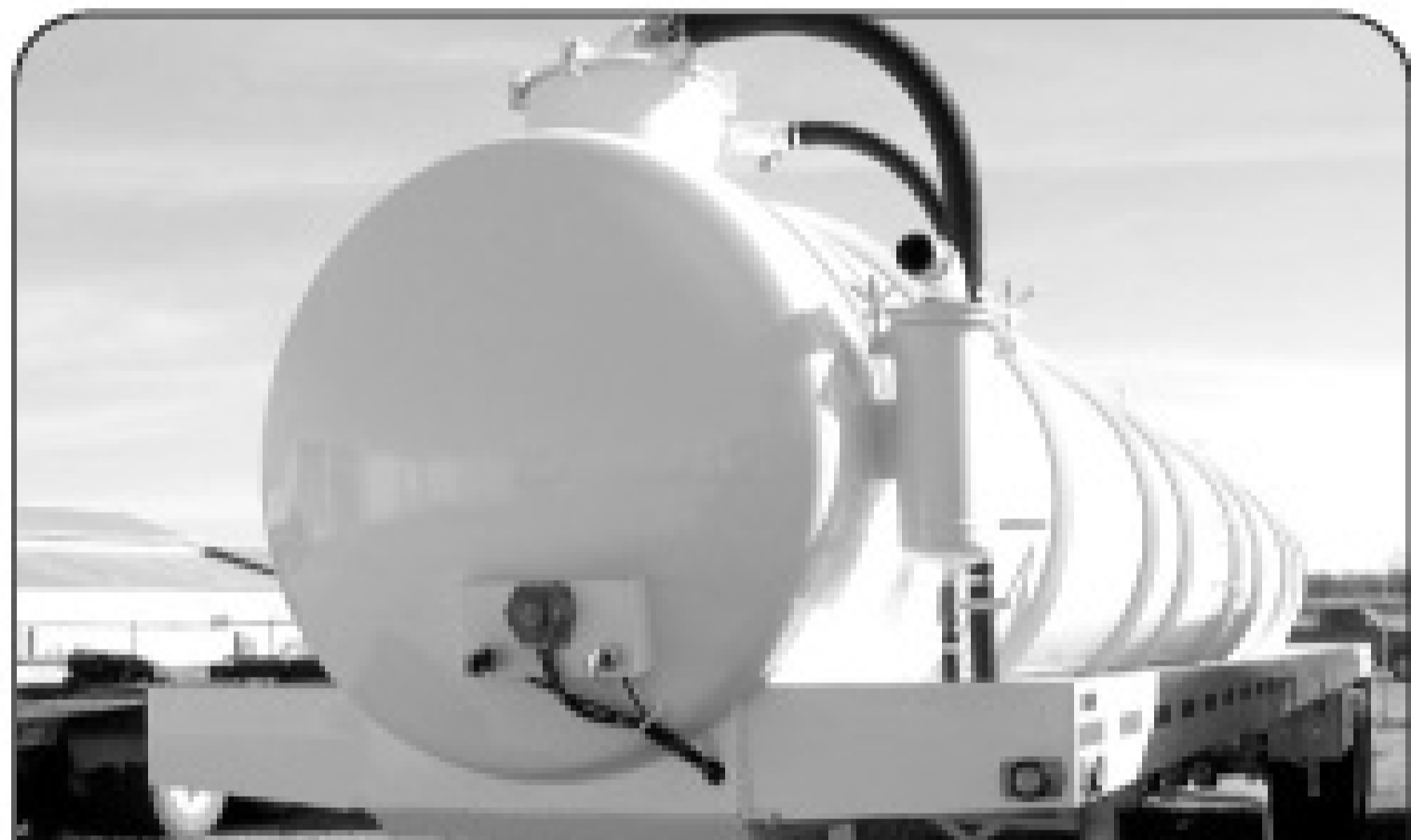

New Fluidmaster 5460 gal. vacuum trailer in stock. Also several used vacuum trailers in stock.



1999 IH 9900, Detroit 60 series (430/500 hp), 10-spd., new Wally 753LN vacuum pump, new 3000 gallon vacuum tank.



1989 Chevrolet C70, 8.2 ltr. diesel, 5+2 air brakes, double frame, MEC 5000 vacuum pump, 1500 gallon vacuum tank.



2001 IH 4900, DT466E, 6-speed, 33K GVW, air brakes, double frame, new Masport HXL75V vacuum pump, new 2300 gallon vacuum tank.

CALL US BEFORE YOU BUY!

MID-CONTINENT TRUCK SALES

manufactures and stocks all necessary components to complete your vacuum system.

Whether it's pumps, valves, moisture traps, oil catch mufflers, pump frames, etc.



LET US QUOTE YOUR NEXT VACUUM TANK!

Kerr Pumps
Since 1946



Masport

NVE

AUTHORIZED DISTRIBUTOR



vallenstein
vacuum pumps

BOWIE



FLUID AND SLURRY
PUMPS

WE CARRY MOST BRANDS OF VACUUM PUMPS AND PARTS!



WE WILL BUILD TOILET UNITS TO YOUR SPECS!

Call DAVE PERRY for TRUCK quotations and CHUCK RODGERS for TANK quotations.

ADVERTISING

SANITATION POSTCARDS & BUSINESS CARD MAGNETS: Remind your customers and prospects with color postcards and magnets. Economical marketing tools. Tradeshow handouts as well. Call Toll Free 888-334-4553. Visit www.postcardprinting.com. (PBM)

BUSINESSES

FOR SALE: Full service septic pumping, grease trap pumping and drain cleaning business on the western slope of Colorado. Business established in 1993 with large established loyal customer base and excellent reputation. Two 2000 gallon vacuum tank trucks (2005 Int. and 1989 Ford with hydraulic hoist), one 300 gallon vac-tank on 1-ton for small grease traps and 1 service truck complete with sewer cleaning and repair tools. All serious inquiries will be given proper consideration. Please contact us at 970-249-1816 or email terck@wildblue.net. (PBM)

Portable toilet business Central AZ, 3 trucks, approximately 200 toilets, 2 handicaps, wash stations, 200 gal. tanks. Over 100 units in service. 928-684-5033. (P4)

FOR SALE: Septic and Portable Toilet Business located in White Mountains, Arizona. 150 toilets, 2 ADAs, 3 trucks. For more info, respond to: 11448 East Monte Ave., Mesa, AZ 85209. (PBM)

NC PUMPER BUSINESS FOR SALE, established 10 years, \$140,000 annual revenues, '99 FL70 2,000 gallon tank, GEM jetter and backhoe. Alan 828-432-2900, aclark@hatterasgroup.com. (P3)

BUSINESSES WANTED: Septic pumping, grease trap, drain cleaning and other ancillary businesses wanted. We are buying well run businesses in New England, Mid-Atlantic and Florida. All opportunities will be given proper consideration. Confidentiality ensured. Will move quickly for the right opportunity. Serious inquiries only. Please contact Richard Bedard @ Blue Water, 617-326-3344 or rbedard@bwseptic.com. (CPBM)

BUSINESSES

FOR SALE: Central Texas portable toilet business. Includes 2,500 units, 10 pump/route trucks, 6,000 gallon nurse tanker, 1 ACSI luxury restroom trailer. Great customer base. Email for more information: centraltexastoilets@gmail.com. (P4)

FOR SALE: 23-year-old restaurant service company specializing in hood system cleaning and ceiling restoration. Serving WV, OH and KY. Large loyal customer base. Grossing average \$500,000. All vans, equipment and experienced service techs in place. \$350,000. Will train. 304-372-2158. (CP7)

Long Island, New York: For Sale: Cesspool, Septic, Sewer and Drain Cleaning Company For Sale. 2 pump trucks, 2 porta-pottie trucks (service and delivery). Quality workmanship, has established 3000+ loyal customer base. Great opportunity for right person. Jump in on busy season! Money maker! Debt free! Office/shop/yard also available. Call for more information. 631-472-0677. (PBM)

BUSINESS WANTED: Septic pumping business in the North New Jersey area, also Rockland, Orange County areas. Complete operations purchased with employment opportunities after purchase. E-mail: septicbuyer@yahoo.com. (P3)

Washington State Puget Sound septic design, installation, maintenance and repair business. Excavating equipment, pump truck, trailer, tools and truck. 5 year office, shop and yard lease available. Training for permitting, installation, maintenance, repair and licensing up to 5 years. \$360K. Terms 888-868-8599. (P4)

BUSINESS OPPORTUNITIES

Attention PolyJohn Owners: Receive a **free CD-Rom** of our products to use in your company marketing efforts. Ask your PolyJohn business coach in your area to send you this material today. 1-800-292-1305 Kell. (PBM)

BUSINESS OPPORTUNITIES

If you are in need of a REGISTERED SEPTIC TANK CONTRACTOR to qualify your Florida-based septic company, send me an email @ BLRSepticService@aol.com or call 561-723-5001. (P4C5)

Existing liquid waste company located in southeastern Wisconsin is looking to expand into septic and drain cleaning services. Individual will have proven skills in being highly motivated and a self starter. Must also be able to work individually. Previous experience in septic and drain services a plus. Prior business ownership would also be a positive. This position will offer ownership possibilities with a salary or a salary base plus commission according to profits. To apply please call Steve Horne at 920-696-3248 Ext.119 or send resume to united_hr@yahoo.com or mail to United Liquid Waste Recycling, INC., P.O. Box 247, Clyman, WI 53016. (P3)

ATTENTION: PUMPER/OWNERS/OPERATORS. Start your own pumpout business. Have FL license, will sponsor. Septic, grease, holding tanks. Malone 321-784-1614. (P3)

INVENTION OF A TRASH CAN WITH NO BOTTOM. Can be used for recycling, leaves collection during fall or trash only. Patent pending. Fill the bag and lift the can, not the bag, and save your back. No workmen's compensation to deal with. Will allow licenses. You buy sub-wholesale and sell wholesale. This ad is to see if there is an interest. Production pending. Call 808-479-1876 or email kiscanllc@yahoo.com. (P3)

National Grease Recycling Inc. Let us teach you how to recycle restaurant's waste fryer grease and oil (yellow grease) only. **No trap grease.** Big \$. Over 30 yrs. experience. Will guide you through complete process from collection to processing to marketing to end users. Don't lose your trap business to competitors that offer both services. Call for information. Dewey Walker. 813-752-9535 or 813-758-2552. (PBM)

BUSINESS OPPORTUNITIES

WWW.ROOTERMAN.COM. Franchises available with low flat fee. New concept. Visit web site or call **1-800-700-8062 x26**. (CPBM)

COMPUTER SOFTWARE

Pumper Plus Billing Software: Regularly \$795. Mention this ad in Pumper.com and purchase for only \$595. Pumper Plus is a billing software package from Galaxy Systems, www.galsys.com/pumperdemo.asp, that handles billing for septic pumping and portable toilet service-type companies. Inquire at solutions@galsys.com or call 800-985-3029. (PBM)

DEWATERING

DeTainer DT30 full stainless steel, cold weather insulation, rolling roof, \$40,500. DeTainer DT30 stainless interior screens, carbon exterior, \$29,950. Muffin Monster grinder w/controls; skid mounted, in-line, \$16,000. DeTainer (2) self tipping hopper units w/stainless interior 3.5-yd., each \$5,000. 21,000 gal. frac tank, CPC, \$26,000. Stacking conveyor for belt press, radial, stainless steel, 18 inches wide, 36 feet long, elecdrive, \$9,500. Pit Hog electric dredge. 1998 Mack spreader truck w/floatation tires and 4,000 gal. Huhn tank, \$40,000. Contact Joe or John 919-938-2955 or joe@atlanticdewatering.com. (P3M4)

DAF, 6X12 F.R.C. All stainless steel w/2 dissolved air pumps. Top paddle and bottom worm drive skimmers removes suspended solids particles and colloidal materials from liquid waste, such as fats, oils, grease, latex, pump and paper fiber. Treating approx. 140 gallons per min. 770-917-0377. (PBM)

Buy - sell - trade - lease: Filter presses, belt presses, vacuum filters, filter cloth, dewatering bags, tanks, mixers and more! Call Waste Treatment Equipment Specialties at 440-808-8844. **www.wescoequip.com**. (PBM)

DEWATERING

Alar, Model 650, very good cond. Completely automatic with all controls and panels, filters down to 1/2 micron, sludges generated by septic and grease haulers. Reducing BODs, F.O.Gs, TGS, total phosphorus, meters and NH3-N. 770-917-0377. (PBM)

DRAINFIELD RESTORATION

2002 Terralift, 500 hours, 3 probes, excellent condition, many extras. Available at Pumper Show or can deliver. \$15,000. 724-297-5435. (P13)

DO YOU OWN A TERRALIFT MACHINE? We have the beads in stock and we also have heavy duty probes. Toll Free 1-888-252-1006. (P4)

DRAIN/SEWER CLEANING EQUIP.

1993 Vactor 2100 Series, 3 yard debris tank. Ready to work. \$8,000. Call for pictures or details. 407-351-0827. (P4C5)

RODDER TRUCK: (Sreco Flexible) 1990 Ford F450 w/123,000 miles, 7.3 L Diesel, auto tran, A/C, sectional rodder. Truck, tires and rodder motor in good condition, needs rodding segments replaced. Check website www.ziamunicipal.com for more information or call 614-419-4579. (CP5)

DREDGES

Seepex sludge & polymer mixing & pumping unit. 5 years old. Excellent condition. Asking \$20,000 OBO. Call 1-506-672-2100. (PBM)

GLOVES

GLOVES brown jersey (100% cotton) 25 dz/cs, latex exam, shoe covers, sewer gloves, cotton, leather, PVC, welding. Any glove is available. Metro Industrial Supply 888-358-1923; www.easygloves.com. Visa/MC. Money back guarantee. (CP3)

PLACE YOUR AD ONLINE AT www.pumper.com - IT'S ALWAYS THERE TO MEET YOUR BUSY SCHEDULE

HAZARDOUS WASTE UNITS

2010 Peterbilt 340s loaded with every option except with automatics with a new Presvac 3200 gallon carbon steel, DOT 412 certified, full open rear door, dump style units. PVB750 vacuum pumps. (Stock #TBD A,B,C&D) In production. **www.VacuumSalesInc.com, (888) VAC-UNIT (822-8648).** (PBM)

1986 Polar 5,000 gallon 316 stainless steel MC 307/312 vacuum trailer with new vac pump and hyd. drive. New tank inspections with new NVE valves. Spring suspension. In excellent condition. Must see. KLM Companies 617-909-9044. (P3)

NEW Presvac 5500 gallon c/s DOT certified vacuum tank unit, self-contained. In stock! (Stock #13373) **www.VacuumSalesInc.com, (888) VAC-UNIT (822-8648).** (PBM)

2000 Mack RD686 triaxle with 4,000 DOT certified dump and door Presvac vacuum tank. New Moro PM100 vacuum pump with new NVE valves and tank inspections. 350 hp engine with 44K rears with 15K pusher, 18K ft. axle. Must see. KLM Companies. 617-909-9044. (P3)

2009 Kenworth T800 steerable tri-axle with new Presvac Powervac 3,800 cfm, DOT 412, wet/dry vacuum unit. 3,200 gallon tank with full open rear door with top loading boom. 475 hp engine with aluminum wheels and fully loaded. Buy or rent. KLM Companies/KLM Rentals Inc. Call 617-909-9044. (P3)

2000 Kenworth T300 cab and chassis with a Presvac 2010 US gallons, DOT certified vacuum tank. In stock. (Stock #4675C) **www.VacuumSalesInc.com, (888) VAC-UNIT (822-8648).** (PBM)

ATTENTION: Fleet of Mack vacuum waste oil trucks for sale/trade by owner. Assorted size MC312 aluminum vacuum tanks. 417-619-5111. (PBM)

2009 Sterling LT9500 triaxle with a new Presvac, **Powervac** 3800, 3,250 gallon (US), DOT, wet/dry industrial, vacuum tank loader. (Stock #13336) **www.VacuumSalesInc.com, (888) VAC-UNIT (822-8648).** (PBM)

JETTERS-TRAILER

Used PipeHunter model 38T44 jetting unit, trailer mounted unit, w/335 poly water tank, 4000 psi @ 25 gpm, 600' hose and attachments. In Stock!!! (Stock #4313V) **www.VacuumSalesInc.com, (888) VAC-UNIT (822-8648).** (PBM)

For Sale: Aries Saturn 3 Camera System with cable reel mounted in a Cargo Sport Trailer, with overhead AC system. For additional cost, will include transporter and camera. Unit has shore power or generator. For more information, contact Woody Willis @ 904-219-6491. (CMP3)

New PipeHunter Model 38T44 jetting unit, trailer mounted unit, w/335 Poly water tank, 4,000 psi @ 25 gpm, 600' of hose and attachments. In Stock!!! (Stock #13317) **www.VacuumSalesInc.com, (888) VAC-UNIT (822-8648).** (PBM)

J2512 Typhoon, 24 hp Koehler engine, 2500 psi; 150 gallon tank. garage kept, excellent condition. Sacrifice at \$8,900 OBO. Contact 727-329-2770. (P3)

New O'Brien Model 3518-SC jetting unit, trailer mounted unit w/350 poly water tank, 4000 psi @ 18 gpm, 400' of hose and attachments. In Stock!!! (Stock #3024V) **www.VacuumSalesInc.com, (888) VAC-UNIT (822-8648).** (PBM)

2 SECA trailer jets. Both have Myers 35 gpm, 2000 psi pumps. New paint on both. Located in Dallas. 972-938-1905. **www.empireequip.com.** (CPBM)

JETTERS-TRUCK

2000 SECA water jet. Front mounted, hose reel, Myers 50 gpm 3000 psi, 1500 gallon plastic water tank. Was a city owned unit. In excellent condition. 714-639-8352. **www.empireequip.com.** (CPBM)

Ford 7000 cabover 1985, standard 5-speed transmission, 53,420 miles. Single engine PTO drive, 1500 gallon water tank, Myers D65-20 pump, \$12,000. 601-373-3736. (P3)

1995 Harben, 925 hours, in excellent condition, mounted on 1998 Ford F800, 5.9 diesel hydromatic, 500 gallon water tank. Asking \$21,000. In Florida. Call 561-740-2010. Cell 396-4469. (CP3)

JETTERS-TRUCK

1986 CHEVY C-65 Cat. Diesel 175K, 5-speed manual split shift. New brakes and tires. Pump-Meyers D-65, 2000 lbs @ 65 GPM. One hour on rebuild. Perkins diesel. 1000 gallon tank. Good hoses and nozzles. Ready to work. \$10,000 OBO. Will also accept a trade for a trailer jett for equal or less value. 770-527-0376. (CMPBM)

2006 GMC TC6500 cab & chassis truck mounted jetting unit with JET EYE camera system, 3,000 psi @ 50 gpm, 1,000 gallons water, 600' hose, 500 cfm blower, debris tank and attachments. RENT ME!!! (Stock #13234) **www.VacuumSalesInc.com, (888) VAC-UNIT (822-8648).** (PBM)

JET VACS

1992 Camel Ford L-8000. Rebuilt Jasper motor, 10,000 miles, 262 hours. 9-yard debris tank, 1000 gallons of water, extendable boom. 65 gal. @ 2000 psi. Great condition, excellent truck. \$35,000. Fredrickson Supply. Todd 888-949-2385. (P3C4)

2001 Vac-Con Model V390 SHA, 3-stage fan, 80 gpm 2000 psi pump, 600' of new 1" jet hose, new paint. Was city owned. 972-938-1905. **www.empireequip.com.** (CPBM)

1994 Vac-Con, 16 debris tank, 1250 gallon water tanks, articulating reel, slitshaft for vacuum, L8000 Ford, 128,000 miles. \$50,000. 601-373-3736. (P3)

1994 Guzzler, Ford LNT8000, 126,250 miles, 275 hp, auto transmission, 9-cy debris tank, 16" Roots blower, Myers water pump, 2000 psi @ 80 gpm, 1500 gal. capacity, 8' extendable boom. Good condition. Reduced to \$62K OBO. 716-523-6813 after 5:00 pm. (CP3)

1997 Clean Earth, Ford LNT 8000, 98,575 miles, 275 hp, auto transmission, 4-cy debris tank, 16" Roots blower, Myers water pump, 2000 psi @ 80 gpm, 2000 gal. capacity, 4' extendable boom, rear mount hose reel. Good condition. Reduced to \$47,500 OBO. 716-523-6813 after 5:00 pm. (CP3)

1986 Vactor 1200 on a Ford L-8000 w/3208 Cat w/Allison auto, 68000 miles. Pony motor, 6V53 Detroit w/4365 hrs. Body washout, recir. and anti-freeze systems. \$12,500. Jim @ 313-849-2667. (CP3)

JET VACS

Looking for a couple late model Vactors with low hours. Please contact Steve @ River City Environmental, Inc. 503-969-7591. SteveM@rivercityusa.com. (CP5)

1996 Vactor Model 2110, **PD blower**, 65 gpm, 2000 psi pump, 10-yard debris tank, new paint. 972-938-1905. **www.empireequip.com.** (CPBM)

VACTOR 1994 remanufactured Model 2115, 100 gpm @ 2,500 psi pump, two-stage fan. Many options. \$49,000. Call 440-352-9472 Cell 216-299-1396. (P3C4)

CAMELS: 2008 Camel 200 DEMO unit, only 8,500 miles+/- Like new with Cat Diesel, Sterling tandem chassis, 10 cy dump, front reel mount, winter circulation and vacuum excavating packages, never titled. 1997 Camel 200 on Ford LT8515 tandem chassis. One owner truck with only 67,000 miles, Cummins 275 Diesel, auto shift, 10 cy dump body and behind the cab reel. 1990 Camel 200 on a Ford LNT 8000 chassis w/a Ford Diesel, auto shift, 10 cy body, front reel and only 42,000 miles, municipal owner. Check website **www.ziamunicipal.com** for more information or call 614-419-4579. (CP5)

1998 Vac-Con V312THA on a Ford LT8000, 3-stage fan, 65 gpm, 2000 psi pump, extendable boom, articulating hose reel, 12 yard debris tank, new paint. Was a city owned unit. Located in Dallas. 972-938-1905. **www.empireequip.com.** (CPBM)

2008 Sterling LT7501 with a Vac/All Safe Jet Model AJV1215 1500 water comp, 12-yr. debris body, Roots 824 PD blower, 80 gpm @ 2000 psi jetting system with 600' of 1" hose. Combination vacuum-jetter unit. In stock - RENT ME!!! (Stock #0329V) **www.VacuumSalesInc.com, (888) VAC-UNIT (822-8648).** (PBM)

1998 Vactor 2110 on a Freightliner FL80, 28,213 miles, 2-stage fan, 80 gpm, 2,000 psi pump off system accumulator. Was a city owned unit. Located in Dallas. 972-938-1905. **www.empireequip.com.** (CPBM)

(1) 2002 Vactor 2110; (1) 2002 2115; (1) 2003 2110. **All PD units.** All were city owned units in excellent condition. Located in Dallas. 972-938-1905. **www.empireequip.com.** (CPBM)

JET VACS

1998 Vac-Con Model V350THA, 3-stage fan, 50 gpm, 3000 psi pump, 5-yr. debris tank, new white paint. Was city owned. 714-639-8352. **www.empireequip.com.** (CPBM)

Jack Doheny Supplies Inc. offers a full range of late model combo units and DOT industrial vacuum loaders. Call us @ 1-800-3DOHENY. (CPBM)

2008 Sterling LT7501 with a Vac/All Safe Jet Model AJV1215 1500 water comp, 12-yr. debris body, Roots 824 PD blower, 80 gpm @ 2000 psi jetting system with 600' of 1" hose. Combination vacuum-jetter unit. In stock - RENT ME!!! (Stock #0330V) **www.VacuumSalesInc.com, (888) VAC-UNIT (822-8648).** (PBM)

1998 Clean Earth, Ford Louisville, 136,900 miles, 275 hp, 10-speed Eaton Fuller, 10-cy debris tank, 27" Roots blower, variable speed Myers pump, 2000 psi @ 80 gpm, 1500 gal. capacity, 8' extendable boom. Also serves as a hydro-excavator. Good condition. Reduced to \$77,500 OBO. 716-523-6813 after 5:00 pm. (CP3)

LEASE/ FINANCING

NEW AND USED EQUIPMENT FINANCING. Quality off lease and reconditioned repos available to buy, lease or rent. Competitive rates and flexible terms. **Call Brad @ 610-942-3930.** (PBM)

BSM Financial Group is a nationally recognized finance company. We offer flexible payment schedules for all types of equipment new or used. Trucks, pumps, jetters, portable toilets, and software easily financed. We do first time start-ups, established businesses, and challenged credit. **Call Brett at 877-524-7972 or email brett@bsmfinancialgroup.com.** (PBM)

North Star Commercial Credit: Commercial Loans for Trucks or Equipment. Flexible purchase programs to fit your budget. 21 yrs. in the industry. Contact **Tom Myers - 877-804-2274.** (CPBM)

Grow Your Business Today! Get competitive financing. No payment for 6 months. Seasonal plans! No age restriction. Don't wait. Liberty Capital Group, Inc. 888-798-3976. (PBM)

BUY IT - SELL IT - PLACE IT - **www.pumper.com** - AVAILABLE ANYTIME, ANYWHERE, ANY DAY

MISCELLANEOUS

DISCOUNT ALUMINUM:

ARE YOU PAYING TOO MUCH? 1,000 lb. minimum quantity. 5052/5454/5083/5086. .063 - 5.0" thick. All widths. Contact Jayson. 1-888-540-0066. (PBM)

2004 Wee Engineer 27', 12-unit hauler, either 12 standard units or 8 standards + 1 handicap. Excellent condition. \$5,500 OBO. 815-970-7253. (PT4)

Top quality aerators at wholesale prices. We have replacement units for most name brands and also carry Linear Regenerative Rotary Vane pumps. Flagg Air, Gast, Thomas, FPZ, Secoh, Medo and more. Call a company that understands aerators and aeration systems. Septic Services Inc. 800-536-5564. (CPBM)

PARTS & COMPONENTS

Piranha Horizontal Hose Repair Machine (Swaging): 1- Vactor snorkel nozzle kit #50507, 1- O'brien root cutter with spiral blades 6", 8", 10" 1- Hydro Excavation tube and misc. Vactor parts. \$1,200 takes it all. Please call 802-948-2082. (P3)

PARTS & SERVICE for vacuum pumps and vacuum tanks. Vacuum pumps also in stock. 800-909-6909. Ask for Ken or Randy. (PBM)

PORTABLE HAND-WASH STATION

POLYPORTABLES SUPER TWIN HANDWASH STATIONS: 1 year old, used once. \$395 each. 715-896-0413 or 715-284-5979. (P5)

PORTABLE RESTROOMS

500 Olympic Fiberglass units for sale. Units are older construction grade. Located in Albuquerque, New Mexico. \$100 each. Call 505-345-3965. (PT4)

New and used portable restrooms for sale in Middle Tennessee area. Contact: Tony 931-320-2255. (P5)

Half Units: Good condition, 300 PolyJohn half units, 300 sling units and regular units for sale. Contact Manuel @ 305-970-9837. (P3)

PORTABLE RESTROOMS

50 PolyJohn PJN3 - FOB Spokane - \$250/ea. 509-244-8404. (P4)

35 used portable toilets, \$175 each. Good condition. 10 used 250 gallon holding tanks, \$100 each. Call 888-463-7687. (PT4)

4-year-old PolyPortable Integra tan portable toilets in great shape. \$300 per unit. Call Vince at 775-721-8484. (Northern Nevada). (P3)

New portable restroom, 2-station, fiberglass exterior, 204 gal. waste, metered faucets, waterless urinal. \$9,850. Rich Restrooms. 260-593-2279. www.richrestrooms.com. (P3)

100 green PolyJohn units. Units are in excellent shape. Located in southeastern Michigan. We can provide transportation. Call at 248-529-3159 or e-mail at info@portabletoiletsmichigan.com. (PT3)

Used PolyJohn, PolyPortable tan units, plastic skids, average to excellent condition. \$225-\$325 each. Can arrange shipping. Call Bob at 1-352-796-4540. (PBM)

Over 600 PolyJohn units 1-2 years old. Starting at \$300 each. Minimum purchase of 26 units. 772-562-4604. kim@reliablepolyjohn.com. (PBM)

Portable Toilets: Poly constructed, molded seat, urinal, latching door. Handicap accessible units available. New and used. CCI/Brian Touey 805-896-3777. (PBM)

PORTABLE RESTROOM TANKS

300 gallon, 225 waste/75 water, brand new, Battioni pump. \$5,500. 315-375-7867. (PBM)

Single or multiple compartment tanks. Choose mild, stainless, or galvanized steel. Capacities from 100 to 6000 gallons, any diameter. Parts and accessories to build your own and save money. 800-545-0174. www.tanksandpumps.com. (PBM)

PORTABLE RESTROOM TRAILERS

2006 Wells Cargo Comfort Elite III. Light use, stored inside. \$19,750. 573-896-8665. (PT5)

PORTABLE RESTROOM TRAILERS

Polyjohn 40' Event Trailer, newly remodeled with all new floors, walls and sinks. It has a family changing room. Asking \$35,000. 509-244-8404. (P4)

Quality built and reasonably priced restroom trailers. Our trailers have 2 stalls, 1 urinal, and a sink in a 6'W x 7'H x 12'L metal frame with white aluminum walls. All piping is concealed in the walls. They come with heater / AC, strong metal steps and mirror on a tandem axle frame. Price \$14,950. Call us @ 817-558-1923. (PT3)

New and used SandDollar Comfort Loos restroom trailers for sale. 864-787-6989. (PT3)

Trading two new 18' bathroom trailers for two new shower trailers. Serious inquiries only. 608-835-3459. (P3)

Restroom Trailer - Gold Series: 32', new and used. Women's - 5 stalls, 2 sinks. Men's - 2 stalls, 2 urinals, 2 sinks. CCI/Brian Touey 805-896-3777. (PBM)

New and used **RESTROOM TRAILERS** available immediately. 8 to 34 foot luxury trailers. Comforts of Home Services Inc. 877-382-2935. (PBM)

Restroom Trailer - Platinum Series: 30', new and used. Women's - 4 stalls, 2 sinks. Men's - 2 stalls, 3 urinals, 2 sinks. CCI/Brian Touey 805-896-3777. (PBM)

PORTABLE RESTROOM TRUCKS

2007 Ford F-550. Satellite set up with a 600 gal. waste and 300 gal. fresh. Low miles, 54,755. Like new. \$38,500. Please call 314-776-4000. (P4)

1990 International pumper truck, 300/600. Asking \$18,000. 509-244-8404. (P4)

1997 Ford Super Duty, 550/120, Conde Super 6, used daily, newly painted, 200,000 miles. Wis. 715-927-7290. (P3)

Aluminum Portable Toilet Tankers: '02 F-650; '02 Isuzu; '02 Inter.; '02 Inter.; '03 Inter.; '03 Inter.; Masport pump, pressure cleaners; 500 clean & 1500 waste. Contact Manuel @ 305-970-9837. (P3)

PORTABLE RESTROOM TRUCKS

2005 F-550 Super Duty, 6.0 diesel powerstroke, automatic, AC, purchased from Satellite, fresh chem. delivery, pressure washer, Conde pump, 650 waste/300 fresh, 2-unit rack, no salt, 145,000 miles, washed daily, kept in shop nightly. Call 701-471-4098 or 701-224-0856. Ask for Bruce. (P3)

1994 Super Duty F-450, 21K with Masport pump, 600g waste, 200g water, 7.3 diesel, automatic transmission. Runs good. \$8,500 OBO. 989-345-1763. (P3)

1998 International 4700 cab and chassis with a Coleman 1,000 US gallon, 2-compartment (700/300 split) carbon steel portable restroom service unit. **Available!!!** (Stock #1327C) **www.VacuumSalesInc.com, (888) VAC-UNIT (822-8648).** (PBM)

2000 International Portable Toilet Truck: 750 gal. waste, 250 gal. freshwater, 5-spd, 7.3 diesel motor with 125,000 miles. Located in Maryland. \$11,000. Doug 410-310-5151. dougierson@piersoninc.com. (PT3)

1200 gal. tank, USED, 1000/200 split, new Masport 130 cfm pump, new Honda 9 hp electric start. \$8,500. Financing available. Call for details. 785-231-0834. (P3)

1994 International 4700 with a Keith Huber 1,500 carbon steel portable toilet service unit. (Stock #6499V) **www.VacuumSalesInc.com, (888) VAC-UNIT (822-8648).** (PBM)

1999 Ford F450 diesel, manual, aluminum vac tank, 300 waste, 170 fresh, hot water, flat bed and lift gate. 2004 Freightliner FL50 with new bed and vac unit. Pictures at www.robinsonsepticsservice.com. 814-355-4474. (P3)

2001 Isuzu FTR, 2005 Crescent tank pumper, 25,900 GVW, 152,000 miles, runs good. New transmission, new tires, 1000 waste, 300 fresh. Will trade for restroom trailer. \$28,850. FSBO. 585-657-1010. (PBM)

1995 International 4700 with a Prime 1,500 US gallon, 2-compartment (1000/500 split) carbon steel; portable toilet service unit. "As is." **Available!!!** (Stock #3469C) **www.VacuumSalesInc.com, (888) VAC-UNIT (822-8648).** (PBM)

PORTABLE RESTROOM TRUCKS

1998 F-800 w/stainless 200/100, 5.9 Cummins w/Allison auto, 80,000 miles, holds 10 units. \$20,000 OBO. 334-319-1412. (PT4)

1999 Freightliner w/automatic with a Keith Huber 1,000 waste, 500 water, toilet service unit. (Stock #4506V) **www.VacuumSalesInc.com, (888) VAC-UNIT (822-8648).** (PBM)

2004 4300 International, 25,500 GVW, DT466, Allison, A/C, airbrakes, 3-compartment aluminum tank (450/1400/250), M-10 Water-cooled pump, spot lights, 2 Burk water pumps for fill and spray down, restroom carrier. Pictures www.aacoinc.com/classified. Located Phoenix, AZ. \$45,000. 208-362-3193. (P3)

1994 Ford with Coleman 700 waste, 300 water toilet service units. (Stock #6084V) **www.VacuumSalesInc.com, (888) VAC-UNIT (822-8648).** (PBM)

LOOKING FOR a 2005 or newer portable restroom truck. All set ready to go or just chassis. Call 517-764-7888 or fax 517-764-7808. (P3)

1998 International 4700 with a 1,500 US gallon, 2-compartment (1100/400 split), carbon steel, portable toilet service unit. (Stock #8734C) **www.VacuumSalesInc.com, (888) VAC-UNIT (822-8648).** (PBM)

2006 International (6H263172) DT466 Model 4300 with Transway tank 2200/300, air brakes, Transway T-250 pump, 6-speed, 11Rx22.5 tires, 33,000 GVW, 42K miles, white cab, green body. 716-823-3606. (P3)

2002 International Pumper Truck: 4700 series, DT466, automatic, air brakes, 1200 gallon waste, 300 gallon fresh water, Masport 75 pump. CCI/Brian Touey 805-896-3777. (PBM)

1999 Ford F550, 7.3 diesel, auto, Satellite 500/200 tank with 2-unit carrier, Conde pump. \$6,000. NY 800-275-3616. (P3)

New 700 US gallon 2-compartment (450/250 split), carbon steel, portable toilet service unit. (Stock #13238V) **www.VacuumSalesInc.com, (888) VAC-UNIT (822-8648).** (PBM)

PLACE YOUR AD ONLINE AT www.pumper.com - IT'S ALWAYS THERE TO MEET YOUR BUSY SCHEDULE

PORTABLE RESTROOM TRUCKS

2005 International (5H166614) DT466 Model 4300 with Transway tank, 1500/300, air brakes, and air ride suspension, Transway 250 vac pump, 6-speed, 11Rx22.5 tires, 32,000 GVW, 35K miles, white cab, green body. 716-823-3606. (P3)

2008 Ford, 49,000 miles, \$45,000. 2007 C5500 Chevrolet, miles in 40s with aluminum and steel tanks. Still under warranty. Slide-ins 600/200, \$10,000. Portable toilet transport trailers: 8, 10, 12, 14, 16, 20 haulers. New portable toilet trucks and new and used septic trucks. We stand behind everything we sell. Lane's Vacuum Tank Inc. 1-800-592-3308. (PBM)

2007 Dodge 3500, new flatbed, 4 dr., 4x4, all power, Cummins, auto., with new 750 gal. service unit, Honda/Masport. \$29,500 offers. Financing available. 785-231-0834. (P3)

2006 Peterbilt 366, less than 2,000 miles, 6-spd., 2600 GVW. Progress aluminum tank 1500/500. Masport pump, water pressure, scent tank. Like new! Call for info and pictures. 512-461-2419. (P4)

1999 Isuzu FTR, 190 hp, 6 cyl. diesel, 25,900 GVW, new Allison auto with 2-yr. warranty, Jay's Inc. 1,300 gallon 800/500 split, National 190 cfm vac. pump, Burks DC-10 wash down pump, heated dump valve, heated bucket fill, heated water pump, 60' hose reel, 2-unit toilet carrier, and more. 123,800 miles. \$35,000. Call Dale 708-878-4391. Located in Illinois. (PBM)

POSITIONS AVAILABLE

Regional Manager Position in Jacksonville, FL. Must have experience in industrial waterblasting and vacuuming. Call 423-892-8335; email resume to jobs@universal-serviceinc.com. (PT3C4)

PUMPS-SUBMERSIBLE

(2) 4" submersible pumps with self-contained Lister diesel engine, hyd. drive powerpac. Separate hyd. tanks, both on portable skids. Will run (2) 4" pumps or (1) 6". Must see. \$12,500. KLM Companies 617-909-9044. (P2)

PUMPS-SUBMERSIBLE

Wholesaler for Hydromatic, Zoeller, Myers, Liberty and ABS pumps. We also supply Grinder pumps and basins. Will help you size them. Septic Services Inc. 800-536-5564. (CPBM)

PUMPS-VACUUM

(2) PRESVAC 750 PUMPS: With accessories, gear boxes, 4-way valves. \$5,000 for all, or will separate. 734-365-4035. (P3)

Utile Compressors Vacisystems, vacuum pump for sale. Model LE450 serial # M104653, 350 cfm. \$3,500 OBO. 631-283-1403. (P3)

New **Masport** and **Jurop** vacuum pumps. Compare our price before you buy. W-K Machine & Supply Co. Call 1-800-633-8947. Distributor. (PBM)

Need a vacuum pump for your portable pumper? Try our new 30 cfm, 12 volt system. Less noise, no fuel. Automatic oiling, cheaper than a gas engine. 800-545-0174. www.tanksandpumps.com. (PBM)

Vacuum Pumps - New, used, or rebuilt. 30 to 900 cfm. All major brands; air, water, or fan cooled. Rebuild specialists - rebuilt PB, M3, M10, and others available. 800-545-0174. www.tanksandpumps.com. (PBM)

Complete line of Moro, Conde and engine-driven, stand-alone pump systems, DC10 washdown pump. Call us for any of your vacuum truck parts from shut-off valves, primary and secondary valves, hoses, vacuum pumps and drive systems. Septic Services Inc. 800-536-5564. (CPBM)

PUMPS-WATER

1 or 2 XT-8 pumps, 8", Model X-T8, 14 3/4" impeller, each with 40 hp 400 motors, less than 50 hrs. each. Also available control panels. \$7,500 each pump and motor. 727-576-1111. (CP3)

RENTAL EQUIPMENT

Liquid vacs, wet/dry industrial vacs, combination jetter/vacs, vacuum street sweeper & catch basin cleaner, truck & trailer mounted jettors. All available for daily, weekly, monthly, and yearly rentals. **VSI Rentals, LLC, (888)VAC-UNIT (822-8648) www.vsirentalsllc.com.** (PBM)

ROLL-OFF TRAILERS/TRUCKS

1993 Galbreath AC416 single container roll off trailer. Bridge weight design, just sandblasted and painted with aluminum Budds. Good condition. \$17,500. KLM Companies. 617-909-9044. (P3)

SEPTIC TRUCKS

1994 International 8400 tandem axle pump truck, with 3,200 gallon steel tank. Tank and pump eight years old. Cat motor with 320,000 miles. \$30,000 Neg. 410-472-2723. (P3)

3360 gallon septic/vacuum truck, 2003 Sterling, 137,500 miles, A/C, heat, CD-radio, new injector pump, 300 Cummins, heated valves, 367 Challenger pump. 307-272-4848. (P4)

1984 IHC w/2,600 gal. Jay's tank, MEC 8000 pump, good condition. \$19,500. 715-644-2332. (P3)

1997 Mack, nice, 90% rubber, 550,000 miles, blue, AC, 8-spd., 400 hp Mack power, 3000 gal. tank, Masport pump, 100' 3" hose. \$52,500. Financing available. 785-231-0834. (P3)

1990 Kenworth, 90% rubber, Cummins, 270 hp, 16135 miles, new vac pump, Masport. Must sell! \$22,000 OBO. Call with an offer! 630-674-6928. (P3)

2001 Ford F750, diesel, 6-speed, air brakes, new injectors, 2000 gallon vacuum tank, Battioni pump, 180K miles. \$30,000 OBO. Hamilton, Mich. 616-218-3155. (P4)

1985 Ford F-700 pumper, 2300 gallon capacity, under 90,000 miles. \$20,000 OBO. Must sell. Call Mike for info. 970-434-3113; 970-201-8006. (P3)

1979 GMC 7000, 366 V8, gas, 1200 gallon tank, Lilly Pacific pump, \$2,500. Call 530-877-3207, ask for Roger. (P3)

2004 International Model 4300 series, 2000 gallon Progress tank serial #20980, diesel, AC, Stereo/CD, power steering, 36,000 miles, original owner, want to sell ASAP. \$55,000 OBO. 818-912-1220. (CPT13)

1968 Mack RS700L, 350 Cummins, 2400 gallon tank, runs strong, Lilly Pacific pump, \$4,500. Call 530-877-3207 ask for Roger. (P3)

SEPTIC TRUCKS

TWO SEPTIC TRUCKS FOR SALE: 1990 International and 1995 International. Both have 2300 gal. tanks and Masport pumps. One tank is 4 years old; the other is 2 years. Both in good shape. \$20,000 for 1990 model; \$25,000 for 1995 OBO. 256-490-8089. (P4)

1992 Ford LN9000 with new 4,000 US gallon carbon steel vacuum pressure tank, Presvac PV 750 vacuum pump. 44K rears, 18K ft. axle, 145,000 miles, in excellent condition. \$37,500. KLM Companies. 617-909-9044. (P3)

2006 International 4300 DT466, 6-speed, 2150 gal. steel tank, Jurop R260, 90K miles, A/C. Good clean truck. 1 owner. \$48,000. 903-852-3740. (P4)

1999 Sterling with a 2,500 US gallon CS dump type unit and pump package. (Stock #2192V) **www.VacuumSalesInc.com, (888)VAC-UNIT (822-8648).** (PBM)

2003 International 7500 with a 3,000 gal. carbon steel vacuum tank unit. (Stock #2319C) **www.VacuumSalesInc.com, (888)VAC-UNIT (822-8648).** (PBM)

2002 Presvac 4,000 US gallon C/S tank only. (Stock #6255V) **www.VacuumSalesInc.com, (888)VAC-UNIT (822-8648).** (PBM)

2006 Sterling, Volvo 450 hp, Jake 8 speed. Air ride, AC, cruise control. 3600 gallon alum. tank. Masport pump, tri-axle. 100 gallon fresh water tank w/jetter. FM-CD player. Low mileage. 15,000 miles. \$120,000. Call Ronnie Thomas at 703-398-7762 or 540-428-3986. (P3)

2000 Volvo WG64 with a Pikrite 4,000 gal. vacuum tank and a Jurop PNR-102 pump. (Stock #9010C) **www.VacuumSalesInc.com, (888)VAC-UNIT (822-8648).** (PBM)

2001 Progress 4,800 US gallon C/S tank only. (Stock #0138C) **www.VacuumSalesInc.com, (888)VAC-UNIT (822-8648).** (PBM)

FOR SALE: 1989 Mack DM with 1994 Presvac 3200 gallon steel tank with full opening back and dump, and 1400 cfm Hibon blower. Dumps with full opening rear door. Great for car washes, sediment pits and deep pump chambers. Great for doing car wash pits. \$10,000. Dick Mottolo 978-276-0217. (P3)

SEPTIC TRUCKS

2003 Mack CV713 cab and chassis with a 3,200 gal. s/s vacuum pressure tank. Masport pump package. **Coming soon!!!** (Stock #3680V) **www.VacuumSalesInc.com, (888)VAC-UNIT (822-8648).** (PBM)

2001 Intl. DT-466, 7-spd. tandem, new 3600 gal. tank, Masport 350 cfm vacuum pump, 237,000 miles, \$49,000. 2000 Intl., DT-466, auto., new 2300 gal. tank, 350 cfm Masport pump, 147,000 miles, \$44,000. Other new & used toilet & septic trucks available. Everything we sell has warranty. Lane's Vacuum Tank Inc. 1-800-592-3308. (PBM)

1989 Petro Steel 5,500 US gallon carbon steel vacuum pressure trailer with a front porch mounted PV-750 vacuum pressure pump driven by Deutz diesel engine. (Stock #1142V) **www.VacuumSalesInc.com, (888)VAC-UNIT (822-8648).** (PBM)

2001 International 4900 with a 2,000 gallon, vacuum tank and a Fruitland pump. (Stock #9960C) **www.VacuumSalesInc.com, (888)VAC-UNIT (822-8648).** (PBM)

2004 Peterbilt Model 330C, 76,000 mi., 300 Cat, 3600 gal. tank, TSI500 pump, 3", 4", 6" heated valves, air ride, AC, locking differential and tandems. \$82,500 OBO. Call for more info. 715-484-7711. (PBM)

1985 Ford L-8000 Septic Tank Pump Truck: 2400 gallon tank, Battioni pump, 3208 Caterpillar engine. Daytona Beach, FL. \$9,400. Phone 386-566-2277. (P3)

Need a tank and truck, any size, any make truck? Let us help you get the best deal. Custom built to your specs. For information and a price quote call 800-545-0174. www.tanksandpumps.com. (PBM)

2009 Peterbilt 340 with a Presvac 3600 gallon (US) aluminum vacuum tank unit. **Special Show Pricing!** (Stock #13337 A,B,C&D) **www.VacuumSalesInc.com, (888)VAC-UNIT (822-8648).** (PBM)

2006 Peterbilt 335 with a Presvac 3,600 gallon aluminum vacuum pressure tank with a Masport pump package HXL400WV liquid cooled. (Stock #7504V) **www.VacuumSalesInc.com, (888)VAC-UNIT (822-8648).** (PBM)

SEPTIC TRUCKS

1992 GMC Topkick, good condition, runs well, A/C, 176,000 miles, 2100 gallon tank, Jurop pump. \$24,500. Chicago area. 815-741-4440. (PBM)

1997 Peterbilt Model 357, CAT 3306 motor, Fuller 8-speed trans., 4200 gal. Transway tank, 800 Transway pump, 220K miles, red. Excellent condition, ready to work. \$55,000. 978-618-6110. (PBM)

1991 GMC Topkick, good condition, 2500 gallon tank, PTO pump, full set of hoses, fresh water holding tank, ready to work. \$12,500. 850-497-8421. (P3)

SHOWER TRAILER

Shower Trailer - Gold Series: 32', new and used. Men and women sides each have 3 private shower stalls with changing area, 1 restroom stall, 1 sink. CC/Brian Touey 805-896-3777. (PBM)

SLIDE-IN UNITS

Slide-In Unit: 2001 Satellite MD400. 130/270. Runs good and ready to go to work. Call today! \$1,750. 1-877-295-6955. (P4)

New 500 gal. slide-in unit, 5.5 Honda electric start, 73 cfm Masport pump, vac/pres. Financing available. Call for details. \$6,850. 785-231-0834. (P4)

Vacutrax slide-in portable toilet unit, 450 gal. waste, 210 gal. fresh, all galvanized, new Honda engine, very good shape. \$6,500. 716-676-3388. (P4)

SLIDE-IN UNITS

Best Enterprises (2005) Stainless Steel Slide-in Unit: 300/110, Honda engine, new Conde pump, electric start. Excellent condition. \$7,200. 217-224-1932. (PT3)

750 gal. compact service unit, Honda 5.5 electric start, Masport 73 cfm vac/pres. pump Financing available. Call for details. \$11,500. 785-231-0834. (P4)

TANKS

Used 2003 portable toilet Satellite MD 950 tank in excellent condition. Includes work lights, toolboxes, freshwater pump, 650 waste 300 fresh, ready to mount on truck. Includes 2 toilet carrier and Conde 6SS vacuum pump. \$11,000 OBO. 231-924-8994. (P3)

1100 gallon vacuum/pressure tank. Bare tank w/truck frame mounts. 12' 3" x 50" diam. \$1,500. NY. 845-863-6080. (P3)

FOR SALE: Used 4800 gallon steel Balzer 1/4" thick tank with skids and new valve, good shape. \$4,800 OBO. Delivery available. 515-570-6101. Iowa. (P4)

Vacuum tanks, 100 to 6000 gallons. All options available; hatches, primary, secondary, valves, catwalks, ladders, etc. Everything needed to build your own septic truck. Choose mild, stainless, or galvanized steel. Ask about full open doors. 800-545-0174. www.tanksandpumps.com. (PBM)

2500 gal. Boyd vac/press. tank, complete w/3" Masport pump, lights, valves. Ready to mount & work. Good condition. \$6,000. NY. 845-863-6080. (P3)

TANKS

2002 Presvac 4,000 US gallon c/s tank only. (Stock #6255V) **www.VacuumSalesInc.com, (888) VAC-UNIT (822-8648).** (PBM)

1999 4000 gal. vac tank, has never pumped sewage, always water, new paint, like new, with pump. \$9,500. 541-815-0397 John. (P3)

2001 Progress 4,800 US gallon c/s tank only. (Stock #0138C) **www.VacuumSalesInc.com, (888) VAC-UNIT (822-8648).** (PBM)

New 3400 gallon tank, 20' man-way bottom, 3" intake, 4" dump, hose trays, valves, painted. \$12,000. Delivery available. 800-721-2774. (PBM)

TANK TRAILER

NEW Presvac 5500 gallon c/s, DOT certified vacuum tank unit, self-contained. **In stock!** (Stock #13373) **www.VacuumSalesInc.com, (888) VAC-UNIT (822-8648).** (PBM)

1989 Petro steel vacuum trailer, 5,500 US gallons, carbon steel vacuum-pressure trailer with auxiliary motor and Presvac pump package. "As is". **In stock!** (Stock #1142V) **www.VacuumSalesInc.com, (888) VAC-UNIT (822-8648).** (PBM)

TOOLS

T&T Tools: Probes, Hooks. Probes feature steel shafts with threaded and hardened tips. The insulated **Mighty Probe™** tested to 50,000 volts. **Top Poppers™** open manhole covers easily. Free catalog. **www.TandTools.com.** Phone **800-521-6893.** (CPBM)

TOOLS

Crust Busters - Portable, lightweight machine guaranteed to mix up septic tanks and grease traps! Save time and money! **www.crustbusters.com,** 1-888-878-2296. (PBM)

TOYS

Septic pumper and vacuum die-cast toy trucks in your choice of colors and logos. Several cabs available. Call 877-450-2100 or write to Granite State Collectibles, PO Box 440, New Ipswich, NH 03071. (PBM)

TRAILERS VACUUM/TANKER

Presvac 5500 gal. 316 stainless steel DOT certified vacuum trailer, new Fruitland 500 vac pump w/complete rebuilt Lister diesel engine. Original tank thickness; new tank inspections, no pitting. Excellent overall condition w/new Imron paint. Must see. KLM Companies 617-909-9044. (P3)

Dyna Vac Portable Grease Trap Svc. Unit. Hardly used unit, trailer mounted 200 gal. tank, 49 CFM vacuum pump and 115V elec. motor. Ramp and winch for easy loading/unloading and optional jetters. \$7,800 OBO. 518-885-7324; jimteneyck@aol.com. (CP3)

1988 Heil 5,200 gallon stainless steel vacuum trailer. Spring susp. with disc wheels, 70% plus brakes and tires. Clean trailer. KLM Companies. 617-909-9044. (P3)

TV INSPECTION

1993 GMC Cues TV truck with Dataview III. No camera or tracker. \$10,000. 407-351-0827. Call for pictures or details. (P4C5)

Pearpoint TV Inspection Trucks: 1995, mounted in Isuzu NPR, turbo diesel, low miles, two cameras with small & large transporters, diesel generator, many extras. \$30,000. 559-276-0186. (CP4)

For Sale: Cues Nite Owl pan and tilt camera in excellent condition. \$7,000 (CDN). 506-624-3993. (CP4)

IF YOU ARE USING AN
800 NUMBER
IN YOUR AD, BE SURE IT CAN BE USED
IN ALL AREAS NATIONWIDE.

VACUUM LOADERS

2007 6027 Supersuckers: Mounted on 380 HP Sterling Cat chassis, low hours and miles. \$190,000. Call Mike 219-398-4000 or 888-551-1998. (CP3)

2002 Volvo with 02' GapVax HG57 wet/dry 5,300 vacuum loader, CFM 27" blower, pressure off load, low miles, in excellent condition. Buy or rent. KLM Companies. 617-909-9044. (P3)

1993 Ford with 23,000 miles and a 1991 International with 240,000 miles, hydraulic lift, open hatchback, new pumps and hoses, 70+ barrels, tandem axles etc. Great vacuum trucks! 918-851-7979. (P3)

2009 Sterling LT9500 triaxle with new Presvac Powervac 3800, 3,250 gallon (US) DOT wet/dry industrial, vacuum tank loader. (Stock #13336V) **www.VacuumSalesInc.com, (888) VAC-UNIT (822-8648).** (PBM)

1997 Ford LNT9000, Guzzler, C-11 Cummins, Roots 1021, 27", 5000 cfm, \$59,000. 1995 Ford LNT9000, Vactor XPS, Cat 3176, Hibon, 27", 4600 cfm, \$38,000. 1994 Ford LNT9000, Guzzler, Cat 3406, Roots 1021, rebuilt in 2006, 27", 5000 cfm, \$42,000. 1994 Ford LNT9000, Vactor XPS, Cat 3406, Hibon 27", 4600 cfm, \$38,000. 1993 Ford LNT9000, Cusco MasterVac, Cat 3406, Hibon 27", 4600 cfm, \$43,000. 1989 Ford Vactor 2045, 1020 Holmes 16", 4500 cfm, \$23,500. 1989 Mack Vactor 2045, 1020 Holmes 16", 4500 cfm, \$25,000. All wet/dry units are certified and working as required. Call Rob at 519-384-3416. (P3)

2000 Sterling with Cusco Mastervac 3,800 CFM 27" blower with 3,000 gallon tank. Wet/dry unit with full open rear door and Moro vacuum offloading pump. Low miles/hours. Ready for work. KLM Companies 617-909-9044. (P3)

1992 Ford with Guzzler 4816 with swing out Cyclone 6,000 CFM blower (4 yrs old). Cat engine with Fuller trans. 150,000 miles, 5,000 hours. Runs very good. \$22,500. KLM Companies 617-909-9044. (P3)

1999 International **heavy spec** with **Guzzler ace** wet/dry industrial vacuum loader. 8" top load boom truck is in excellent condition. Blower was reconditioned approximately one year ago. RENT ME!!! (Stock #7390V) **www.VacuumSalesInc.com, (888) VAC-UNIT (822-8648).** (PBM)

Classifieds Category List :: Pumper Magazine
http://www.pumper.com/classifieds/

Pumper SUBSCRIBE EDITORIAL CLASSIFIEDS VIDEO ADVERTISING

Looking to BUY or SELL?
Just Submit Your Classified Ad ONLINE!

Easy & Secure!

Your ad will be posted on the Pumper Web site within two to three business days after received.

Just go to www.pumper.com; click on "Classifieds;" click on "Place a Classified Ad;" fill in the online form.

Only **\$1.00 PER WORD** (\$20 Min.)

VANES

Dura Comp 535, high-quality non asbestos vacuum pump vanes. Good to 400°F. Buy factory direct and save. Same day shipment on most models. Jurup, Battioni, Moro, Masport, Fruitland, Demag. Long lasting Dura-Comp 535 pump vanes carry a "Money-back" guarantee. Call us today. Powerflo Products 800-758-4788 or 562-997-0720. (PBM)

American Industrial Components: Our vanes are manufactured from the highest quality laminated materials available and are fabricated to exact tolerances and specifications. 800-272-7557. (PBM)

WANTED

WANTED: Terralift air compressor (Atlas Copco LT/11). Call 803-312-0038; Cell 803-351-9110. (PBM)

WANTED: Ridgid K-7500 machine, working or not. Call 651-492-8699. (CP3)

Wanted to Buy: Vactor 2100s and late model Guzzlers. Cash. Phone 800-336-4369. (CPBM)

Water jetting equipment. We rent, sell and repair water blasters. Visit us at: www.waterjettingequipment.com or phone 714-259-7700. (CPBM)

WATERBLASTING

Gardner Denver 620-671 Detroit 20K @ 11 gpm. **Gardner Denver** IL450- Volvo 20K @ 17 gpm. **Aquadyne** GA 200 variable speed 3116 CAT 20K, 20 gpm. **Aquadyne** 0450DS-Cummins 20K @ 36 gpm. **Jetstream** 4220-Cummins 20K @ 17 gpm. **Jetstream** UNX-6V53 Detroit 10K @ 26 gpm. **NLB**-Ultraclean Cummins 36K, 7 gpm. **NLB** 10-600 Cummins 10K @ 104 gpm. **NLB** 5-250 Cummins 3600 psi, 182 gpm. **US Jetting Sewer Unit** 4K @ 14 gpm. **Boatman Ind.** 713-641-6006. **View** @ www.boatmanind.com. (CPBM)

WATERBLASTING

2002 NLB-4075D diesel, 40,000 psi, 3 gpm, trailer mounted, 300' new hoses, 620 hrs. Perfect condition. Price \$45,000. Contact 973-476-7194. (CP6)

2003 NLB 10-150 electric waterblaster, (0) hours on unit - never used. Marathon Motor on skid. If you want brand new this is it. Priced to sell @ \$32,500. KLM Companies, 617-909-9044. (P3)

WATERBLASTING

NLB 10-250 2000 model year with 1,200 hrs., 250 hp @ 43 gpm. Complete mounted on 1993 International truck with 120,000 miles. Fluid/power end just rebuilt by NLB. In good shape. \$42,500. KLM Companies, 617-909-9044. (P3)

It's **EASY** to submit your classified **ONLINE!**

Just go to: www.pumper.com

Place a Classified Ad; Fill in the Online Form!

MUNICIPAL SEWER & WATER	Cleaner Pumper	CLASSIFIED AD FORM	PRO	ONSITE installer
--	-----------------------	---------------------------	------------	-----------------------------

Please print ad legibly below with *correct punctuation* and *phone number*. Circle each word to be bolded, if any. (\$1.00 extra per word)

CHOOSE THE CATEGORY:

- | | | | | | |
|--|---|---|--|---|---|
| <input type="checkbox"/> Aerators | <input type="checkbox"/> Dredges | <input type="checkbox"/> Levels & Transits | <input type="checkbox"/> Positions Wanted | <input type="checkbox"/> Root Control | <input type="checkbox"/> Trailers-Vacuum/Tanker |
| <input type="checkbox"/> Blowers | <input type="checkbox"/> Excavating Attachments | <input type="checkbox"/> Locators | <input type="checkbox"/> Pressure Washers | <input type="checkbox"/> Safety Equipment | <input type="checkbox"/> Trucks (dump/septic/misc.) |
| <input type="checkbox"/> Bucket Machines | <input type="checkbox"/> Excavating Equipment | <input type="checkbox"/> Miscellaneous | <input type="checkbox"/> Pumps-Dredge | <input type="checkbox"/> Septic System Components | <input type="checkbox"/> TV Inspection |
| <input type="checkbox"/> Businesses | <input type="checkbox"/> Hand Tools | <input type="checkbox"/> Parts & Components | <input type="checkbox"/> Pumps-High Pressure | <input type="checkbox"/> Septic Tanks | <input type="checkbox"/> Vacuum Loaders |
| <input type="checkbox"/> Business Opportunities | <input type="checkbox"/> Hazardous Waste Units | <input type="checkbox"/> Pipeline Rehabilitation | <input type="checkbox"/> Pumps-Submersible | <input type="checkbox"/> Septic Trucks | <input type="checkbox"/> Vanes |
| <input type="checkbox"/> Cable Machines | <input type="checkbox"/> Hydroexcavation | <input type="checkbox"/> Portable Toilets | <input type="checkbox"/> Pumps-Vacuum | <input type="checkbox"/> Service/Repair | <input type="checkbox"/> Vehicle Tracking |
| <input type="checkbox"/> Computer Software | <input type="checkbox"/> Jetters-Trailer | <input type="checkbox"/> Portable Toilet Tanks | <input type="checkbox"/> Pumps - Washdown | <input type="checkbox"/> Slide-In Units | <input type="checkbox"/> Wanted |
| <input type="checkbox"/> Dewatering | <input type="checkbox"/> Jetters-Truck | <input type="checkbox"/> Portable Toilet Trailers | <input type="checkbox"/> Pumps-Water | <input type="checkbox"/> Sludge Applicators | <input type="checkbox"/> Wastewater Transfer |
| <input type="checkbox"/> Drainfield Restoration | <input type="checkbox"/> Jet Vacs | <input type="checkbox"/> Portable Toilet Trucks | <input type="checkbox"/> Rodding Machines | <input type="checkbox"/> Tanks | <input type="checkbox"/> Waterblasting |
| <input type="checkbox"/> Drain/Sewer Cleaning Equip. | <input type="checkbox"/> Lease Financing | <input type="checkbox"/> Positions Available | <input type="checkbox"/> Roll-Off Containers | <input type="checkbox"/> Tools | |

CHOOSE THE PUBLICATION(S): (Deadlines are for the month preceding issue)

- | | | |
|---|---|--|
| <input type="checkbox"/> CLEANER
Deadline: 1st of the Month | <input type="checkbox"/> PUMPER
Deadline: 10th of the Month | <input type="checkbox"/> PRO
Deadline: 17th of the Month |
| <input type="checkbox"/> MUNICIPAL SEWER & WATER
Deadline: 1st of the Month | <input type="checkbox"/> ONSITE INSTALLER
Deadline: 17th of the Month | |

CLASSIFIED AD RATE:

\$1.00 per word, per month, with a 20-word minimum or \$20.
[\$1.00 extra per bold word (key words only)]

ADVANCE PAYMENT REQUIRED:

No billing for classified ads. Payment must be received in advance before publishing.

CALCULATE THE AMOUNT DUE:

_____ words X \$1.00 = _____ X _____ Publications X _____ Months = \$ _____
(\$20 minimum) # of publications checked above # of months to run the ad Total Amount Due

(Example: 25-wd. ad x \$1.00 per word = \$25.00;
\$25.00 x 2 publications [Pumper & Pro] = \$50.00;
\$50.00 x 2 months to run the ad = \$100.00 Total)

FILL IN COMPANY AND PAYMENT INFO:

COMPANY NAME: _____
 ADDRESS: _____ PHONE: _____
 CITY: _____ STATE: _____ ZIP: _____

MAIL this completed form with payment to:
 COLE Publishing Inc., PO Box 220, Three Lakes, WI 54562

FAX this completed form to: **715-546-3786**

ONLINE forms at: www.cleaner.com
www.pumper.com
www.promonthly.com
www.onsiteinstaller.com
www.mswmag.com

QUESTIONS: CALL 1-800-257-7222

PLEASE FILL OUT CREDIT CARD INFORMATION COMPLETELY INCLUDING V-CODE (3-DIGIT NUMBER FOUND BY YOUR SIGNATURE)

CREDIT CARD NO.: _____ V-CODE: _____ EXP. DATE: _____

CARDHOLDER NAME: _____ PHONE: _____

WE ACCEPT:

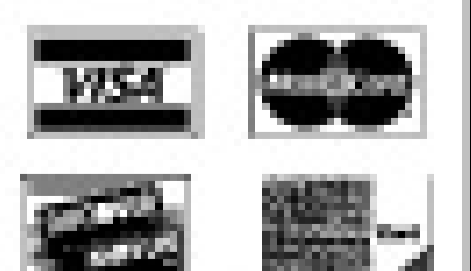



ASHLAND PolyTraps

Grease, Oil, Hair and Lint Traps and Interceptors

- NO Rust or Corrosion
- Lightweight
- Very Cost Effective
- Sizes up to 560 Gallons
- Made in the U.S.A.!

LIFETIME WARRANTY!

Certified by U.P.C., IAPMO and P.D.I.

800-541-8004

PolyTraps@Amplex.net
www.ashlandpolytrap.com

WATER JETS FOR RENT

- Units from 4,000 to 40,000 psi, including convertibles
- 60-800 hp, diesel or electric
- Rent, buy or lease
- Branches in MI, TX, NJ, CA, LA

NLB Corp. 1-877-NLB-7996
www.nlbcorp.com

Aluminum Vacuum Tanks

ALUMATANK

progresstank.com

PORTAVAC

Septic & Restroom Service

FIND LEAKS and Sources of Odor

Quick • Inexpensive • Easy
with the

Superior® 5E

MADE IN THE USA

Electric Smoker

Using Superior® Classic Smoke

1-800-945-TEST

www.SuperiorSignal.com

SOIL SHAKER 2000

Drainfield Restoration

- Pays for itself in 6 jobs or less.
- Buy factory direct
- Universal skid-steer attachment
- Made in the USA

Any questions feel free to call
320-293-6644
or visit our website at
www.soilshaker.com

Major Credit Cards Accepted!

\$35 PER DOZEN **\$189 FOR 6 DOZEN**

- 14" Gauntlet
- Plastic Coated
- Jersey Liner
- Sandpaper Finish Grip
- 1 Size Fits All

Make checks payable to: ADVANCE GLOVE CO.
Please include UPS shipping address.

ADVANCE GLOVE & SAFETY CO.
2638 PICKWICK DR • FLINT, MI 48303
TOLL FREE: **1.800.323.1223**

Mobile Dewatering Service

Municipal & Industrial Sludge Digesters, Lagoons, Ponds, etc.

- Double Belt Filter Press
- Up to 25% Drier Cake
- Professionally Staffed
- US & Canada

Fluid Technology, Inc.

P.O. Box 937, Oxford, OH 45056
Phone: 513-981-7808
E-mail: sales@fluidtechinc.net
Web site: www.fluidtechinc.net

DYE TRACERS

Solutions for:

- Infiltration
- Septic Systems
- Cross Connection
- Leaks and more...

BRIGHT DYES
Division of Rigiscote Chemicals
www.brightdyes.com • FAX: 937-886-9300

NSF Certified to ANSI Z39.91

Thank you for visiting us

FREE SAMPLE 1-800-394-0678

Have you seen the Pumper E-Zine?

Go to **pumper.com** to view the e-zine.

Great Tips. Great Deals. Great Magazine.

Turn the page and stay up-to-date on the latest products, equipment and information for your industry. Over 25,000 of your peers read Pumper each month for the unlimited knowledge it gives them. Each issue shows you new tools, tips to save on expenses, money-saving deals and much more.

Don't miss an issue - Subscribe today!
Call **1.800.257.7222**
or go to **www.pumper.com**

ATTRACT ATTENTION

Marketplace ads are available in color.

Call today to get started **800.994.7990**

PRO PORTABLE RESTROOM OPERATOR

For companies that rent and service portable restrooms, restroom trailers, drop boxes and other equipment for construction sites and special events.

Subscribe today!
It's FREE.

Call: **1.800.257.7222**

Carry A Restroom On Your Pickup or Sport Utility



Hitch Hauler

DA Deal Assoc. Inc. www.dealassoc.com
866.599.3325

PIT HOG PUMPS WASTE

LWT manufactures manned and remote controlled lagoon dredges and pumps. Rental dredges also available.

LWT LIQUID WASTE TECHNOLOGY
1750 Madison Ave., New Richmond, WI 54017
www.lwtpithog.com / 1-800-243-1406

Refrigerator MAGNETS

500 Minimum - Call for pricing

43¢ EACH! Actual Size: 4-1/2" x 2"
1-800-758-2743
254-829-0373
2-color Imprint - Quantity Discounts

Jetter Package

4.0 GPM 4000 PSI

\$1,499
Free Freight

Sewer Camera

\$1,095
Free Freight

Drain Snake

\$329
Free Freight

COMPLETE DETAILS AT
www.AmazingMachinery.com
1-800-504-7435

BLOWERS

Vacuum Blowers/Pumps

- Vacuums to 27" Hg
- Same day shipment from stock

Pre-Piped Packages

- Capacities up through 30,000 CFM
- Ready to install
- Engineered to highest quality standards

• Complete Rebuilt Units
• Spare Parts Inventory

1-800-250-7481

Meyer
Wm. W. Meyer & Sons, Inc.
1700 Franklin Boulevard, Libertyville, IL 60048
www.wmwmeyer.com

One Complete Package

pumper.com eq-mag.com
promonthly.com pumpershow.com
mswmag.com pumpertender.com
cleaner.com septicyellowpages.com
onsiteinstaller.com sewerpages.com

COLE Publishing
1.800.257.7222 • 715.546.3346

JOIN THE DISCUSSION!

Pumper Discussion Forum is an online based tool for industry professionals to swap information and ideas on topics related to the liquid waste industry.
Sign up today at
www.pumper.com

MAKE A SPLASH

Add Color to your Ad

Call
800.994.7990

ONSITE installer

Dig into our pages.

Each issue shows you:

- New technologies to help you win jobs and earn more profit.
- Tips to boost machine performance and drive out costs.
- Money-saving deals on supplies and equipment.
- And much more.

Best of all, you'll learn from other successful business owners — how they did it, and how you can, too.

FREE Subscription — sign up today!

800.257.7222
www.onsiteinstaller.com

ARE YOU TIRED OF RAKING AND SHOVELING?

You should try a **HALL'S GRADE BLADE** on your backhoe or excavator.

- 4 sizes available, 4' to 10', for excavators
- 5 different sizes for rubber tire backhoes and mini-excavators

If you would like to know more, call us toll-free at
1-888-372-8933.
HALL'S GRADE BLADE, INC.
www.gradeblade.com

CONFINED SPACE ENTRY PACKAGE

ONLY \$2,995

The best package on the market includes:

- 4-Gas Air Monitor (3 Year Sensor Warranty)
- 7' Tripod
- 3-Way Fall Protection
- Work Winch
- Full Body Harness

Thank you for visiting us

Add a Blower with 15' of duct for only \$300!
Add a 5 Minute Escape Respirator for only \$500.

Ask About Our

- Harben Jetters
- GapVax Combination Trucks
- Vac Replacement Parts
- Camera Systems
- Nozzles & Hoses
- Blowers & Ventilators
- Magnetic Lid Lifters
- Aluminum Folding Ladders
- Repairs & Service

MTECH 800.362.0240
www.mtechcompany.com

WWW.ROOTERMAN.COM

Franchises available with low, flat fee
New concept. Call 1-800-700-8062.

FRANCHISE PACKAGE \$7,950.

Have you seen the **installer** E-Zine?

Go to onsiteinstaller.com to view the e-zine.

PADLOCKS

- Your Padlocks
- Your Key Number
- Any Quantity
- Best Prices

Quick-Shipped Anywhere!

Master

SERVING THE PORTABLE SANITATION INDUSTRY FOR 14 YEARS— WE'RE THE BETTER WAY TO BUY PADLOCKS™

Call For FREE CATALOG or Instant Quote!

LockMasters
1-800-461-0620
www.lockmastersusa.com
sales@lockmastersusa.com • Fax (850) 914-9754

T&T TOOLS **T&T Tools**
800-521-6893
800-521-3260 FAX
E-mail sales@tandttools.com • www.tandttools.com

Mighty Probe™
Sludge Hoe™ (insulated)
Sludge Spud™
Manhole Hook
Tommy Hook™
Striking Head™

Handy Hook™
Water Probe
Curved Spud™
Top Popper™
Ground Buster™
Smart Stick™ (standard)

www.tandttools.com

It's A Bag Full

pumper.com

- > Classifieds
- > Truck Stop Ads
- > E-zines
- > Product Categories



Marketplace advertising

1.800.994.7990

Deadlines:

Pumper: 10th of the month*

*PRECEEDING ISSUE DATE

Pumper

Pumper Marketplace gives you nationwide exposure to thousands of industry professionals. **Now Available In 4-Color**

Layout and design is included **FREE**, and we can fax or e-mail you a proof for final approval!

Choose a size that works best for you!

Size A: \$319^{00*}

1.875" w x 4.875" h

This size is great for 2 photos!

Size B: \$219^{00*}

1.875" w x 3.2" h

Perfect size for one photo!

Size C: \$119^{00*}

1.875" w x 1.5" h

A great value!

*Black and white prices, call for 4-color pricing.

[Send ad materials and payment to:

COLE PUBLISHING INC. • P.O. BOX 220 • THREE LAKES, WI 54562]

Pumper

see photos in COLOR at www.pumper.com

TRUCK STOP



March



(2) 1995 Ford L-8000, Vac-Con V-350: 8.3 Cummins 275 H.P., John Deere diesel upper, 600' 1" hose, telescopic boom, 3-stage blower, well maintained municipal trucks.\$29,900 Each
814-696-4343 - Hollidaysburg, PA OMP3



1995 Mack CH613: E7, 350, spl. 10, 4500 gal., full DOT door, 300 water, jetter 12 gpm, 2,000 psi, 700 cfm, Demag, full tire tread.\$59,750
727-576-1111 CP3



2002 Western Star: C-12 8LL 20/46 43K miles with 15-ton crane, \$115,000. '05 Cat 420D L/B 800 hrs., \$52,000. '01 T-40 20-ton trailer, \$9,500.
Package price \$150,000
Kevin @ 850-333-1651, Baker, FL P3



1995 International: 4000 gallon S/S Progress tank, 1500 rpm Wittig pump.
\$45,000
956-726-9999 P4



2003 International: DT466 engine, auto trans., under CDL, A/C, cruise, new 2000 gal. tank and Jurop PN84 vac pump, new paint, super nice truck.\$37,500
877-898-5104
hullstruckbodies.com P3



1999 Mack CH613: E7, 427, 13 spd., 4500 gal., full DOT door, 300 water, jetter 12 gpm, 2,000 psi, 700 cfm, Demag, full tire tread.\$69,750
727-576-1111 CP3



Purchased New 05/2007 Pre-Emission Kenworth T-800: C15 475 Acert. 475 hp, Fuller 10-spd., Concept 2000/5300 gal. alum. tank, 2 compartments. (5000 waste/ 300 fresh), 3 full-size anti-surge internal baffles. Jetter sys. w/300' hose\$160,000
570-881-2775 P3



Belt Press Semi Trailer Mounted: 2.0 meter press capable of producing cake sludge of 24% or more and up to 300 gpm, reversible load conveyors, twin polymer tanks w/mixers, polymer blend system, A/C control room w/complete cabinets. Unit is in show condition.\$165,000
863-956-0315 OMP3



1999 IHC 2674, Vac-Con VPD-3116: ISM Cummins 400 H.P., Allison auto., 46 rears, 824 Roots blower, municipal truck.\$59,900
814-696-4343 - Hollidaysburg, PA OMP3



2004 International 4300 DT 466: Air brakes, air conditioning, new 2150 gal. tank, new 400 Masport pump, liquid cooled, new tires on rear.\$45,000
937-372-1113 P3



1986 Chevy C65 Cat: Diesel 175K, 5-speed manual split shift. New brakes and tires. Pump-Meyers D-65, 2000 lbs @ 65 GPM. One hour on rebuild. Perkins diesel. 1000 gallon tank. Good hoses and nozzles. Ready to work.\$10,000 OBO
 Will also accept trade for a trailer jett of equal or less value.
770-527-0376 ICPBM



1999 IH 4900 with Jay's Tank: 2600 waste/150 water, MEC 8000. Available April 2009.\$35,000
715-723-8008 P3



2003 Ford E-450 High Cube Van: Diesel engine (90,500 mi) and diesel 8kw Onan generator (6,169 hrs). RST single conductor reel, WinCan software, Omni-Eye III zoom w/ tractor. Will paint box.
\$65,000 OBO
909-422-1430 P3



2003 Vactor: Sterling chassis, PD blower, 80 gpm pump @ 2500 psi, single rear axle, rotating hose reel, 8' extending boom, Eaton transmission. Excellent shape.
\$85,000 OBO
909-422-1430 P3



1991 Volvo/White: 6570 miles, 315 Cummins, Gap Vax 27 pd, Hibon 5000 cfm blower, new debris body late 1998, pressure dump, 3177 hrs. \$40K or poss. trade
618-527-5846 P3



2004 Chevrolet C6500: 64,760 miles, 8.1L gas, great mileage, 6-spd. manual, A/C, 1200 gal. Precision tank, Masport 75 pump, new shocks, rear tires, fuel tanks rynolined, 5' toolbox, excellent condition.
\$20,000
217-498-7519 P3

Pumper

see photos in COLOR at www.pumper.com

TRUCK STOP



March



2000 Sterling: C-12 Cat 8LL, 3250, full opening rear door, hoist unit, Challenger 460 pump, jetter unit, stainless hose trays, stainless heated valves.....\$51,500
607-769-0172 P4



1997 Vac-Con Model V390THA: 71,000 miles, 8-spd. trans., 65 gpm, 2000 psi pump, 3-stage fan, hydrostatic drive, extendible boom, 600' of new jet hose, new white paint.\$57,500
Craig 714-639-8352 CPBM



2000 Pearpoint Pipeline Video Inspection: Color camera P494 pan/tilt, P599 drum, 1000', P420 tractor, recorder, P377 controller, 110V gen., fully self-contained, refurbished by Pearpoint, ex-city. \$34,500
Phil 562-926-5015 or 562-824-1093 CWP3



2000 Freightliner FL70: 230 hp, 3126 Cat, 368,436 miles, Moro M10 pump, daily user. New tires, clutch & brakes. Must sell!\$26,000 OBO. Call with an offer!
630-674-6928 P3



2006 Safevac - Six (6) To Choose From: Sterling LT9511 chassis, MBE 460 engines, 27" Wispair blowers, OMSI transfer cases.\$165,000 Each
Call 1-888-739-0838 P3



1999 International DT466: Diesel, auto., Coleman PSB950, 3 compartments, stainless steel w/fiberglass skirting and cabinets, hot water wash sys., dual unit carrier, Gold 150 vac pump. One unit left.\$29,500
Call Judge Coleman 516-398-5638
Email: cwjudge@aol.com P3



2000 F250 Diesel Ford Extended Cab: 300 waste/110 fresh. Works daily.
.....\$19,000
248-535-5288 P3



1994 Vactor GMC White Cabover: Cummins 6 cylinder x2, 1,000 gallons, 5 yards, dual fans, excellent condition.
.....\$59,900
Contact Bill at 1-866-744-9921 CP3



1997 International 9200: Cummins 370 hp, 10-spd., Jake, 97,000 miles, 3600 gal. steel tank, Moer 300 cfm pump, clean and ready to work.\$34,000
David 772-473-3716 P3



Shower and Restroom Trailers: Platinum and Gold Series, new and used available. Each with separate men and women sides.
CCI/Brian Touey 805-896-3777 P34



1986 International S-Series F1954: New steer tires, DT466 diesel motor, Eaton Fuller trans, new brakes, 190,000 miles, in-truck rebuilt motor 60,000 miles ago, daily worker. Must sell!\$14,000 OBO
630-674-6928 P3



2001 Freightliner: 3126 Cat engine, 5-spd. trans., air brakes, under CDL, AC, cruise, new 2100 gal. tank and Jurop PN84 vac pump, all new paint and accessories.
.....\$35,500
877-898-5104
hullstruckbodies.com P3



Cues CCTV Inspection Van: Diesel, 16' box, Onan diesel generator, 53K miles, 2005 Kodiak Duramax.\$125,000
Bill Kendrick, 866-744-9921 CP3



1995 Ford L9000: Cummins M11 engine, 10-speed transmission, 3800 gallon steel tank and Jurop R260 vacuum pump. Tank and pump just over a year old, very little use. Comes with hose ready to work.
.....Price reduced won't last at \$44,000
435-691-2316 P3



2006 Spartan Model 798 Trailer Mounted Sewer Jet: Rated at 4000 psi @ 18 gpm, 55.4 hours.Asking \$22,000
Call 1-888-739-0838 P3



1993 International 4900 DT 466: 250 hp, 33,000 GVW, 6+1 trans, new motor 80,000 miles, 2,350 gallon tank, Jurop R260 pump, cab repainted, new tires. Great starter truck.\$35,000
770-898-3761 - Georgia P3

Pumper[®] see photos in COLOR at www.pumper.com

TRUCK STOP



March



1998 Freightliner FL 70: 2000 gal. septic pump truck, 190,000 miles. Pump & truck in good condition. Will sell for \$23,500 or will trade for a 20,000 gallon FRAC tank.
Call Charlie Plumley anytime!
770-962-9962 P3



2002 Freightliner FL80: 3,800 gal. tandem, Cat 250 HP, 9-spd Eaton Fuller, 156,649 miles, 11x22.5 tires, 26#F-58#R Transway TSI-800 pump, 2-4" & 1-6" valves, jetter system.....\$53,900
chrisdunn@lapinservices.com
for pics/questions, Ph: 321-436-0150 P3



2007 Mack CTP7138: 6,000 miles, 405 hp, 6-spd. auto, 20/46, all aluminum wheels. Air ride seats, AM/FM/CD. 4,000 gallon steel tank, Challenger 506 pump. No FET tax..... \$115,000
Kevin 850-333-1651 - FL P3



2001 International: N-14 Cummins, 10-spd., AC, cruise, spring suspension, new 3600 gal. tank and Jurop R260 vac pump, new paint and tires.....\$59,500
877-898-5104
hullstruckbodies.com P3



2004 Sterling Pump Truck: 1500 gal. w/100 fresh, 68K miles, runs 100%, Masport PTO pump, new tires, GVW 27,500.\$45,000 OBO
MUST SELL ASAP!
201-945-9900 P3



2006 Peterbilt 335: 300 Cat, 10-spd., 2000 gal. Imperial tank (1500 waste/500 fresh), 3" inlet, 2 side service, only 5K miles! New truck!Asking \$71,900 OBO
815-970-7253 P4



1994 C-70 Chev: 1200 gal. tank, Mec pump, 366 cu. in., 5x2. Resort truck, like new, good rubber, MNDOT cert., only 26,700 miles.....Price Reduced
612-940-9161 P3



1997 Mack RD600: Double framed, 11.24.5 tires, E7-350 engine, 18#F-44#R, 4,000G steel w/baffles, Transway TSI-1200 pump, 227,973 miles, 6" & 4" valves.\$39,900
chrisdunn@lapinservices.com
for pics/questions, Ph: 321-436-0150 P3



2002 International: DT466 engine, 6-spd., AC, cruise, new 2000 gal. tank and Jurop PN84 vac pump, new paint and tires.\$35,500
877-898-5104
hullstruckbodies.com P3



2001 Isuzu Toilet Truck: 17,900 GVW, mfg. by Prime tank, 600 gal. waste, 250 gal. fresh, 164,000 miles. Priced to sell.\$17,500
Call Frank King 978-452-7750 P3M4



1987 Auto Car L10 Cummins: Engine, head, and radiator rebuilt Sept. 2006. Steel 4000 gallon tank with a 1-year-old Battioni 220 cfm pump.
Call 717-629-1597 or 717-738-2149 P4



1994 Chevy Kodiak Vac Truck: Cat 3116 @ 250 hp, 8LL, 4,000 gal. tank with National Vac unit, 16K/40K axles, 237K miles, 22.5 tires, new paint.\$24,500
715-546-2680 P3M4



1995 Ford L9000: Cummins M11 engine. 10-speed transmission, 3800 gallon steel tank and Jurop R260 vacuum pump. Tank and pump just over a year old, very little use. Comes with hose ready to work.Price reduced won't last at \$44,000
435-691-2316 P3



1994 Ford L9000 Aero Max: 3200 gal. vac tank 5 years old, 260 Jurop pump. Located in Maryland.\$25,000 OBO
443-309-6745 P3



2000 Sterling: 470 hp Detroit, 10-spd., AC, cruise, new 3500 gal. tank and Jurop R260 vac pump, new paint and tires, beautiful truck.\$53,000
877-898-5104
hullstruckbodies.com P3



2009 New Dewatering Filter Boxes: Complete roll-over tarp sys. w/wind guard, epoxy coated, 4" fill port, 3" drain ports, 6" wash-out ports, sealed tailgate, designed for hi-dump vac trucks. 15-yd. \$24,500; 30-yd. \$32,500. 550 gal. polymer sys. unit w/mixer, skid mounted, \$9,000.
Call for more info. 863-956-0315 CMP3

Pumper

see photos in COLOR at www.pumper.com

TRUCK STOP



March



1999 Peterbilt 379: Super 10, air ride, Challenger 506 pump. 2005 Long Horn trailer: 7000 gal., alum. vac/pressure tank, air ride, digital level gauge.\$110,000
805-643-7871

FOR JUST \$125
YOUR TRUCK STOP AD WILL APPEAR IN
PUMPER®, PUMPER® TRADER, and ONLINE
at www.pumper.com and www.pumpertrader.com!



JUST FILL OUT THE FORM BELOW,

OR GO TO www.pumper.com OR www.pumpertrader.com
and fill in the ONLINE FORM!

TRUCK STOP

See photos in **COLOR** at
www.pumper.com,
www.pumpertrader.com
www.cleaner.com,
www.mswmag.com

Pumper/Pumper Trader

Cleaner



Advertising

BE ONLINE & IN **CLEANER, PUMPER & PUMPER TRADER**
or **MUNICIPAL SEWER & WATER FOR ONLY \$125!**

Please print ad legibly with correct punctuation and PHONE NUMBER. Don't forget to send photo!

RATE \$125 PER AD, PER MONTH, PER PUBLICATION WITH A 30 WORD MAXIMUM – **PLEASE NOTE:** You can only advertise **ONE TRUCK** for sale per ad.

DEADLINES **CLEANER: 1ST OF THE MONTH • MSW: 1ST OF THE MONTH • PUMPER: 10TH OF THE MONTH** – For example: July 10th would be the deadline for August Pumper.

ADVANCE PAYMENT **NO BILLING FOR TRUCK STOP ADS.** Payment must be received in **ADVANCE** before publishing in Cleaner, Pumper or MSW.

Enclosed is \$ _____ for _____ ad(s) to run _____ month(s) in
 CLEANER **MSW** **PUMPER/PUMPER TRADER** **ALL PUBLICATIONS (TRIPLE DOLLAR AMOUNT)**

Company Name _____

Address _____ Phone _____

City _____ State _____ Zip _____

• **MAIL** this completed form with payment and photo to:
COLE Publishing Inc., P.O. Box 220, Three Lakes, WI 54562
(Make check/money order payable to: COLE Publishing Inc.)

• **ONLINE** ad form at: www.pumper.com, www.pumpertrader.com,
www.cleaner.com, www.mswmag.com

• **FAX** this completed form to: 715.546.3786 and **E-MAIL** photo to:
truckstop@pumper.com, truckstop@cleaner.com, truckstop@mswmag.com

PLEASE FILL OUT CREDIT
CARD INFORMATION
COMPLETELY:

CREDIT CARD NO. _____ V-CODE _____ EXP. DATE _____

CARDHOLDER NAME _____ PHONE _____

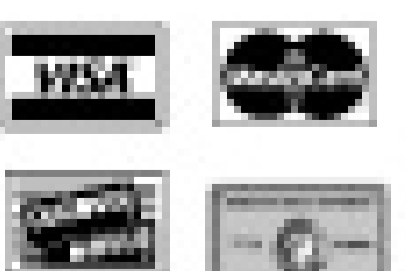

Protecting Your Great Invention

Follow these steps to give your latest great contraption or gizmo quick, easy and inexpensive patent protection

By Fred S. Steingold

If you've come up with a good product idea for the liquid waste industry, you'll face a dilemma that perplexes many an inventor: You want to make sure no one steals the idea. At the same time, you're reluctant to spend \$5,000 to \$10,000 (or even more) to file a full-fledged patent application, using a patent attorney.

Maybe you need more time to explore the commercial possibilities of your invention before committing the big bucks to manufacture and market a new product.

Fortunately, there's an easy way to resolve this dilemma. You can file a "provisional patent application," which will safeguard your claim for up to a year. This is a do-it-yourself procedure that lets you buy time before you decide to take the full plunge. Like a full-blown patent application, the provisional version is filed with the U.S. Patent and Trademark Office.

In their book, *Patent Pending in 24 Hours*, attorneys Richard Stim and David Pressman say filing a provisional patent application offers these benefits:

- You can take up to 12 months to decide if your inven-

tion will be profitable before you spend thousands of dollars on a regular patent application.

- You can use a "Patent Pending" notice to head off competing inventors.
- You can delay building and testing your invention.
- You can establish an official filing date for your invention.
- Your application is kept confidential.
- Your patent's expiration date is extended if your patent is later approved.

In their book, Stim and Pressman recommend you begin the process by checking on earlier patents to avoid spinning your wheels on something that's not actually a new product. You also want to avoid claims of patent infringement. For convenience, you can conduct much of your research online.

THE APPLICATION

A provisional patent application consists of two main parts: a drawing and a description. The drawing of your invention can take many different forms. Certainly, a line drawing will qualify. But so will a flow chart, a schematic or a photograph. The

Fred S. Steingold practices law in Ann Arbor, Mich. He is the author of Legal Guide for Starting and Running a Small Business and The Employer's Legal Handbook, published by Nolo. Legal strategies may vary depending on the state in which you live and the specifics of your situation. See your lawyer for legal advice.



You can file a "provisional patent application," which will safeguard your claim for up to year. This is a do-it-yourself procedure that lets you buy time before you decide to take the full plunge.

drawing must be understandable and fit in a regular file folder.

If you're artistically challenged, review the dozens of practical tips that Stim and Pressman offer in their book. And if you're still intimidated by producing a graphic representation of your invention, you can always hire a graphic specialist to produce one — hopefully at a modest cost.

The description or text part of your provisional patent application can be written in plain English rather than in the technical, formal style required for a full patent application.

The heart of the application consists of four types of information:

- The parts or components of your invention.
- How the parts or components connect or interact.
- How your invention achieves its result.
- Alternative ways, if any, that your invention can achieve its result.

If this sounds a bit abstract, don't worry. The Stim and Pressman book provides several sample applications you can use as a model for your own. Remember, it's OK to write in the first person: "I invented a device for removing seeds from watermelons."

Feel free to use bulleted lists. They can make your application easier to read. To make sure you're communicating clearly,

ask a friend to review your application and give you constructive criticism. If you're still uncertain, have a patent lawyer review your efforts.

FINISHING UP

You can file your provisional patent application by mail or online. You'll find details at the patent office site (www.uspto.gov) or in the Stim and Pressman book. For small businesses, there's a \$100 filing fee; for others, the fee is \$200.

Once you've filed your provisional patent application, you can mark your application "Patent Pending," or refer to it that way. If you manufacture your invention, mark it — and the packaging — "U.S. Patent Pending." But don't do this for more than a year, unless you file a regular patent application.

Although you have a full year to file a regular application, don't wait until the last minute. At least two or three months before the year is up, start preparing your regular application if you're convinced that your invention can be profitable.

You can still file a regular application if you've missed the 12-month deadline, but you'll lose some benefits.

For details, see *Patent Pending in 24 Hours*, available at bookstores, online booksellers, libraries, or directly from the publisher, www.nolo.com. ■

Have It Your Way



Rent - Lease
Lease/Purchase

27' Late Model
Vac Trucks

SPECTRUM

Spectrum Industrial Services - (205) 664-2000 or Toll Free (888) 739-0838

**We have
it ALL...**



Non-CDL
19,500 GVW to
66,000 GVW
Septic / Grease Trap
Portable Restroom
Vacuum Service



Complete 'Work Ready'
Units Available
Call for pricing



800-261-9009



Contact: Mark C. Langworthy
e-mail: mlangwor@tanktruckservice.com
www.tanktruckservice.com
Tank Truck Service & Sales, Inc.
25150 Dequidre, Warren MI 48091

POWER BOOSTER



Patented Technology for Pumping

PL Pressure Lift Corp

- CONQUER DEEP LIFTS AND LONG HOSE RUNS
- REDUCE PUMPING TIME
- MASTER LIFT STATIONS
- INCREASE PROFIT MARGIN

CALL FOR
FREE DVD



Thank you for visiting us in Louisville

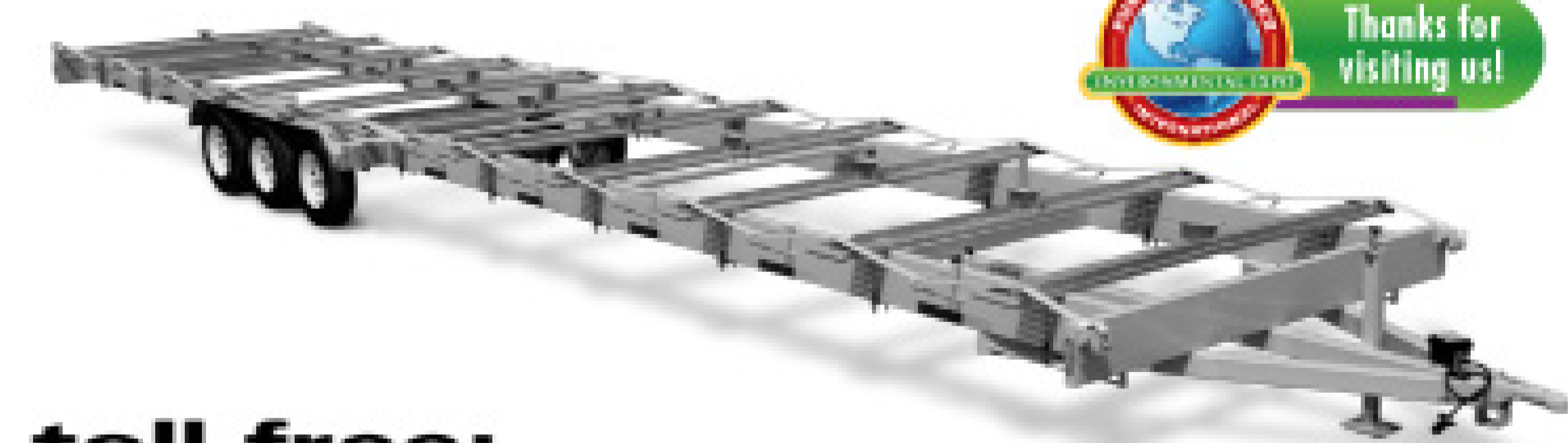

toll free:
(866) 457-5425

EXPLORER Toilet transporters

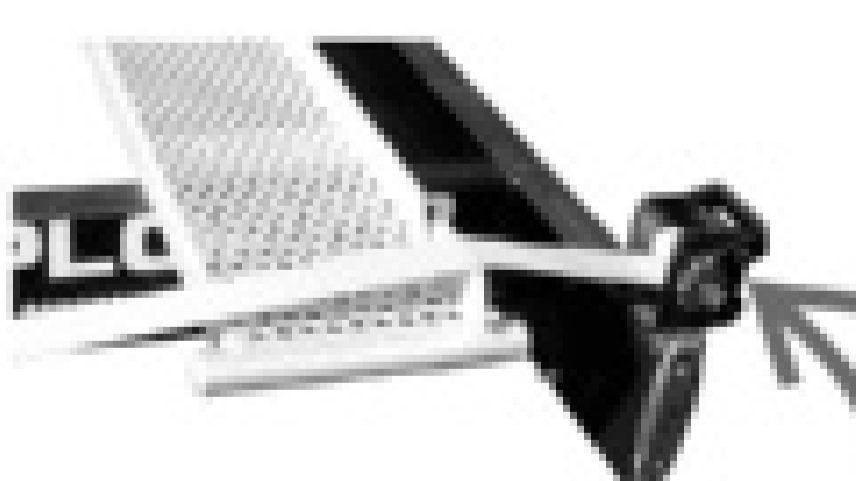

Secure Transportation
for portable toilets with
wooden or plastic skids!



POSI-STRAP POSI-CLAMP

Distribution Centers

California	Colorado	Texas	Florida	Alberta
Plumas Sanitary Tel: (530) 832-0370 Fax: (530) 832-0373 Portola CA	Columbia Sanitary Tel: (303) 526-5370 Fax: (303) 526-9686 Golden CO	Woyl Enterprises Tel: (903) 586-6493 Fax: (903) 541-0874 Jacksonville TX	Steve Bais Enterprises Tel: (407) 709-8175 Fax: (407) 822-3598 Apopka FL	Ted Hoover Tel: (403) 946-4108 Crossfield AB

Manufactured by:
McKEE TECHNOLOGIES INC.
ELMIRA, ONTARIO, CANADA N3B 2A1

visit us on the web
www.explorertrailers.com

Pump Deeper – Pump Quicker
972.355.0550
www.pressurelift.com

Accent Manufacturing IFRS Separator

in the
SPOTLIGHT

By Ken Wysocky

Removing non-biodegradable materials from septage and hydro-excavating waste is a key concern for pumpers who face ever-rising disposal fees and transportation costs. **Accent Manufacturing Inc.** of Abbotsford, British Columbia, tackles that problem with the **IFRS 36 separator**, a front-end dewatering system that significantly reduces water content in waste material, says Darryl Loewen, sales and marketing manager for the company.

Aimed at companies that haul septage and perform hydro-excavation, the unit employs a 1/16-inch stainless steel screen to separate water from solid waste. If the 1/16-inch screen is too small for a particular application, it's easy to substitute larger 1/8- and 3/8-inch screens.

"They take only minutes to replace," Loewen says. "It's like putting a bullet into a rifle — it's very simple."

The 36-inch-diameter screen rotates on four rubber-coated, stainless steel wheels instead of via belts or chains that can wear or require lubrication. In addition, an automatic cleaning system eliminates screen clogs and ensures consistent flow rates, Loewen says.

The unit is hydraulically powered, which eliminates the safety issues related to using electric motors around water, and requires only 3/4 horsepower to operate. The unit can run off a hydraulic power pack or a truck's hydraulic system, and offers variable speed control.



The IFRS 36 has a compact design to fit in many locations (above). The unit is hydraulically powered and can run off a truck's hydraulic system.



"Hydraulics make it simpler," Loewen notes. "It allows

the operator to speed up or slow down the motor, which allows maximum throughput with different kinds of materials."

Another feature is the unit's bypass chamber, which handles excess material when volume exceeds processing capability. This is important because it eliminates the need for valves, which can clog and stop work, Loewen says.

"We elevate the machine so the discharge end is higher than the intake end," Loewen explains. "Gravity forces excess material back into the chamber, where it's recycled back to the pump when the machine is ready to process it."

The separator is simple to install and

can be operated manually or automatically with or without supervision. When used as a permanent receiving station, the unit has reduced operators' waste sludge costs by 30 percent. In a mobile configuration, the separator has been used in digester cleanout projects. **For more information: 877/855-4890, www.accentmanufacturing.com.**

SMC Introduces Envirotub Grease Storage Container

Envirotub from SMC Grease Specialist Inc. features an indoor container that can store up to 55 gallons of grease or an outdoor container that can store up to 1,200 pounds. Made of recycled plastic, the indoor container fits under most two- and three-compartment sinks. The outdoor container features a self-closing lid and containment to catch overflows and spills. Its non-stick surface makes for easy cleaning and eliminates grease buildup. **For more information: 866/777-4322; www.envirotub.com.**



Jet Adds Preventative Maintenance Packs

Jet Inc. added BIO JET-7 dry packs to its line of biological supplements for onsite systems. Quick-dissolving packages are pre-measured for individual doses. The product is designed to digest grease, fats, soap, scum, colloids and organic materials in anaerobic and aerobic wastewater treatment systems. Other additions to the BIO JET-7 series include Plus, Ammonia Away, Sludge Away, and pH Fix Up. **For more information: 800/321-6960; www.jetincorp.com.**



Ritam Technologies Adds Bankcard Processing

Integrated automatic bankcard processing has been added to the Summit Service Profit Builder and Summit Rendering Profit Builder programs from Ritam Technologies. Card payments are automatically added to bank accounts via secure Internet connection. The programs also capture approval codes and report declines. Other program updates include city and state instant lookup by postal code, consolidated reporting for multi-division companies, large and small work order diagrams, picture or document attachments, more flexible password controls, invoice number assignment tracking, additional sales reports and summaries, contract pricing option and more. For more information: 800/662-8471; www.ritam.com.

Thompson Offers 4-Inch Dry-Prime Pump

The modular 4-inch, dry-prime pump from Thompson Pump and Manufacturing Company Inc. features a high-efficiency impeller design and delivers flows up to 1,450 gpm, heads up to 150 feet with solids up to 3 inches. The unit utilizes a fuel-saving 3-cylinder diesel engine and offers three priming systems, including compression/venturi, vacuum pump and diaphragm primer. For more information: 800/767-7310; www.thompsonpump.com.



Blue Angel Launches Oil Detective Sump Systems

Oil Detective Sump Systems from Blue Angel Pumps are designed to detect the presence of oil in various applications. The systems include cast iron and cast iron/stainless steel pump, pump controller, audible alarms, visual display lights, preset on/off, 20-foot piggy-back switch cord and UL508-approved switch. Pump options include 1/3 hp for flows up to 65 gpm at 5 feet or 1/2 hp for 50 gpm at 20 feet. For more information: 888/636-6628; www.blueangelpumps.com.

Zoeller Offers Effluent Turbine Filtered STEP Systems

Effluent turbine filtered septic tank effluent pumping systems from Zoeller Pump Co. are designed for simplex or duplex applications in a single polyethylene pump vault. Made to fit most specifications, its flat bottom design is for freestanding applications, while pipe supports are offered for suspended applications. The inlet is predrilled from the factory or blank for field customization. The deep pleated filter design yields high surface area, while the large, unobstructed area for float placement reduces the risk of hang-ups. For more information: 502/778-2731; www.zoeller.com. ■

TRI STATE TANK

3600 Gallon Septic Tank
Masport HXL400 water cooled
2008 International 4400
310 HP, 10 speed trans.
\$105,950
Monthly Lease From...
\$1828 Plus FET



'Guaranteed Credit Approval'
BUY IT NOW! \$99*

*Per month until August 2009, thereafter regular payments for 60 months with no residual buyout.

IN STOCK Selection of
PRTs & Septic Service Trucks

2007 Chevrolet 7500 'Old Emission'
200 HP 7.8 liter, auto. trans, hyd. brakes, AC.
2000 Gallon 1500 Waste - 500 Fresh
Masport HXL4, Burks washdown,
Hot Shift P.T.O w/remote

\$73,329
As Low As **\$1265** mo.



Call Us At
800-971-7657
Fax: 913-281-9152
www.tristatetank.com



**GET MORE JETTER
FOR YOUR DOLLAR!**

We include all the options,
others charge extra!

UVJ Models
5 gpm @ 4000 psi
Cold Water \$5995
Hot Water \$7995

**NEW
Models**



**Don't see what you want?
We do custom fabricate!**

Fully Loaded Models
7 gpm @ 4000 psi \$10199
11 gpm @ 2500 psi \$11999
15 GPM @ 3000 psi \$18399
20 gpm @ 2000 psi \$ 19999
18 gpm @ 4000 psi \$37899



See our complete lineup from economy models,
van mounts, portables and more on the web at:

www.camspray.com

800-648-5011

Dewatering Equipment



Use The Right Equipment To Get The Best Results.

- Liquid Reduction = Reduced Transportation Costs
- Dewatering = Reduced Tipping Fees
- Non-Organic Separation = Facilitate Land Application of Liquids

ACCENT
MANUFACTURING INC.

Designed for Simplicity. Engineered for Durability.

Toll Free: 877.855.4890

info@accentmanufacturing.com • www.accentmanufacturing.com

NEED SOFTWARE?

THE service program 

The Leading QuickBooks® add-on Software for today's Portable Sanitation Business.

- Software now starting from \$49.95 per month. PC based.
- Interface with QuickBooks® -The Service Program generates your recurring route billing and seamlessly allows you to print the invoices in QuickBooks®
- Easily Manage Routes
- Palm and Windows PDA Handheld Support w/Remote Sync
- Track Pick-Ups & Drop-Offs
- Works with Mapquest® and Mappoint®
- Track Inventory at Multiple Locations
- 30-Day Money Back Guarantee-Leasing Available
- 30 Day No Risk FREE Trial with Weekly Training
- FREE Updates

866.480.1879
www.theserviceprogram.com

DECALS • SIGNS • LABELS • & MORE!

We Specialize in Waste Management Labeling Solutions

- Service Records
- Lock out Tags
- NRC Records
- Warning Decals
- Logo Signs
- Gender Signs
- Service Call Forms
- Service Tags

All Printing & Signs Can be Customized at No Additional Charge

Anchor Graphics
Labels & More

Tele: 972-422-4300 • 1-800-875-7859
Fax: 972-422-4311 • www.anchorgraphics.com
E-mail: info@anchorgraphics.com



Introducing the Most Durable and Economical Septic Lid in the Market Today.

Cost Effective
6 Pack Shipping



Thanks for visiting us!

Now Offering
Custom Lids!

- Durable Roto-Molded Construction WILL NOT Crack Like Concrete!
- Lightweight Polymer is Easier to Handle & Transport
- Corrosion Resistant Stainless Steel Screws Included
- For use with Standard 18" and 24" I.D. Corrugated Pipe
- Easy Slide-in Installation
- Optional Sand Filled

Roto Solutions

800.868.0973

Don't Waste Money On Expensive Riser Systems!

Come In
We're

OPEN

www.pumper.com

ART'S TRUCKS & EQUIPMENT

View Our Entire Inventory
Online: www.artstrucks.com
3001 West Expressway 83
McAllen, Texas 78503
956.686.2326 Fax 956.686.5179
1.800.292.7007
www.artstrucks.com



1999 VOLVO Combo Sewer Truck,
VOLVO-275HP Diesel Engine, Allison 3560
Automatic Trans., A/B, A/C, 55,604 Miles,
Vac-Con Sewer Cleaner, John Deere Rear
Diesel Eng., Lot #2815680 - \$75,500

1996 GMC Sewer Truck, CAT 3126
Diesel Engine, Automatic Transmission,
A/B, A/C, VACTOR 2100 Combo Sewer
Cleaner, 145,054 Miles Lot #2915854 -
\$69,500



1992 FORD Vacuum Truck, 7.8L Diesel
Engine, Automatic Transmission, A/B, 2000
Gallon Tank, 90,154 Miles, Will Dump, Lot
#2714962 - \$23,500

2000 STERLING Combo Sewer Cleaner
Truck, AT Diesel Engine, Automatic Trans-
mission, A/B, A/C, Vac-Con Unit, J. Deere
Rear Diesel Engine, 32,044 Miles, Lot
#2815804 - \$79,500



Have you seen the **Pumper** E-Zine?



Go to pumper.com to view the e-zine.

Get More Income with Every Tank Pumped!

With

PRO-PUMP®

The Finest Name in Biological Products for Septic Systems,
System Recovery, Odor Elimination and More...

Our Top Selling PRO-PUMP®/SEPTIC SAVER!



**SEPTIC
SAVER**

PRO-PUMP®/SEPTIC SAVER is
a combo pack of our two best
selling septic treatments:
PRO-PUMP®/HC & SP packets,
bundle packed as a monthly
(12) treatment program.

- Septic System Treatment
- Absorption System Recovery
- Aerobic System Treatment
- Drain & Grease Traps
- Solids Reduction
- Odor Control
- Bio-remediation

Thanks for
visiting us
in Louisville!



FREE TRUCK DECALS! Show your customers
you sell the very best for their septic systems!

Call Greg Toll Free at 1-800-326-7867 and
Become a PRO-PUMP® Pro Pumper Today!

Professional Sales Materials &
Technical Support at No Charge!

We provide technical support, combined with informative
sales and marketing materials, and we don't sell direct to
the consumer! All web-based inquiries are sent to you!



Solving Problems, Naturally!
Ecological Laboratories INC.

CORPORATE OFFICES: 13 Hendrickson Ave., Lynbrook, NY 11563
TOLL FREE: 1-800-326-7867 • FAX: 516-823-3440 • EMAIL: info@propump.com

Visit our web site at: www.propump.com

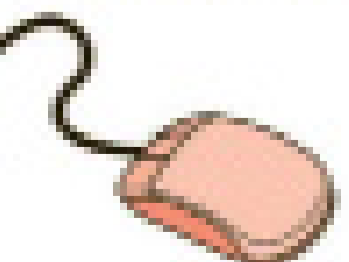

By **Scottie Dayton**

NATION: Groups Renew Commitment to Effective Water Management

Wastewater trade groups and the U.S. Environmental Protection Agency, along with 13 water quality organizations, have signed a Memorandum of Understanding for Decentralized Wastewater Management, renewing a commitment to improve national decentralized wastewater treatment system performance.

Goals of the agreement include strengthening partnerships and improving practitioner competency, management practices, research and technology transfer, accountability, control and oversight through enhanced state, tribal, and local program implementation.

Improving public awareness, education programs and information materials are viewed as ways to help local officials make better decisions, as is supporting the principles outlined in the EPA Voluntary Management Guidelines and Management Handbook for Decentralized Systems.

The three-year agreement involves the Consortium of Institutes for Decentralized Wastewater Treatment, the National Association of Towns and Townships, the National Association of Wastewater Transporters Inc., the National Environmental Health Association, the National Environmental Services Center, the National Onsite Wastewater Recycling Association Inc., the Rural Community Assistance Partnership Inc., the Water Environment Federation, the Association of State and Interstate Water Pollution Control Administrators, the Ground Water Protection Council, the State Onsite Regulators Alliance, the Water Environment Research Foundation, the Association of State Drinking Water Administrators, and the Association of State and Territorial Health Organizations.

The groups will work to advance the awareness of decentralized systems as potential answers to centralized infrastructure challenges, and provide opportunities to implement innovative technologies, develop water scarcity strategies and implement long-term sustainability initiatives in urban and rural settings.

MISSOURI: Installer Training Program Slated

CIDWT, NOWRA and NEHA selected the Missouri Smallflows Organization to host their new Installer Training Program, March 5-6, in Liberty, Mo. The optional NEHA exam follows on March 7. For information, visit www.mosmallflows.org/CIDWTrainingCourse.html.

OREGON: Fees Increase 40 to 60 Percent

The Oregon Onsite Wastewater Association newsletter reports that the state Department of Environmental Quality is requesting approval to increase fees for site evaluations, existing system inspections, permits, product reviews and variances by \$1 million for 2009-2011. The 40- to 60-percent increases, effective in early 2010, take into account rising program costs. Application fees were last increased in 1998.

While onsite applications decreased about 35 percent in 2008, the DEQ still received more than 2,500 applications. The additional revenue would restore 2.5 full-time positions at the agency to process

applications. Without the increase, two offices will close and another will reduce its staff, increasing delays.

NOVA SCOTIA: Septage Treatment Facility Assistance Offered

Nova Scotia onsite leaders, in partnership with Nova Scotia Environment regulators, are providing new options for managing liquid waste. According to the newsletter of the Ontario Association of Sewage Industry Services, one initiative — the four-year, \$2.75 million Septage Treatment Facility Assistance Program — offers assistance to septage lagoon operators to upgrade facilities or construct replacements, as well as technology to meet the department's revised guidelines for the handling, treatment and disposal of septage.

The septage treatment program enabled the municipality of the District of Chester to become the first in the province to purchase the Altinex dewatering truck, which pumps septic tanks, then dewateres the septage using Masko Zoll technology. Liquid is returned to the septic tank and the dewatered solids are composted. The truck, developed in Norway, was refitted on a North American chassis by ABCO Industries Ltd, Lunenburg, Nova Scotia (www.abco.ca).

Another initiative, the Environmental Home Assessment Program, provides onsite owners with a septic system assessment, water-quality sampling kit, water-saving device and samples of environmentally friendly septic system cleaners. After the assessment, participants who want their tanks pumped will receive a \$100 rebate. Low-income households may be eligible for a grant up to \$3,000 to repair their systems.

The agency also issued pilot approvals for SoilAir, MicroFast, and RetroFast pretreatment units for existing onsite systems with disposal fields designed by professional engineers. The department approved the Ecoflo peat module treatment system and the Micro-Modular peat filter system for onsite systems. The latter, a lightweight filter produced by Brookfield Concrete Products Ltd., was subjected to extensive testing and presumed to be the first study in the province that assesses the treatment efficiency of a peat filter exposed to different loading rates.

IOWA: State Claims Most Certified Installers

According to the National Environmental Health Association, the Iowa Onsite Wastewater Association leads the nation in certified onsite installers. The state has 27 contractors, followed by Ohio with 19. This is the second year Iowa has taken the lead.

Training & Education

Soils Information Online

Soil survey manuscripts with soils, data, maps, diagrams, tables, and other details are online at <http://websoilsurvey.nrcs.usda.gov>. Posted by the United States Department of Agriculture-Natural Resources Conservation Service, the Web Soil Survey allows visitors to create and print a soils map for any U.S. location and obtain reports on the suitability of the soils.

The reports identify potential soil limitations including depth to a restrictive layer, predicted seasonal high water table, potential for

flooding, and suitability for sewage disposal. For assistance with the program, call Dani Aleshire at 541/967-5925, ext. 124 or e-mail dannelle.aleshire@or.usda.gov. Anyone living in a county without an online soil survey manuscript should contact their local NRCS office for a copy. To find the nearest office, visit <http://offices.sc.egov.usda.gov/locator/app>.

Sand Fact Sheet Available

The Ohio State University Extension published Sand Size Analysis for Onsite Wastewater Treatment Systems: Determination of Sand Effective Size and Uniformity Coefficient. Graphs and tables in the four-page fact sheet explain why the most important feature of the sand is not the grains, but the pores the sand creates. It's a free download at <http://ohioline.osu.edu/aex-fact/pdf/0757.pdf>.

Onsite Tour

The New York Onsite Wastewater Treatment Training Network has an Alternative Onsite Wastewater Treatment Technology Training and Project Tour on May 27-28 in Skaneateles. Call SUNY Delhi at 607/746-4545 or visit www.delhi.edu/bcs/otn_wastewater/training_events.php#alternative.

Alabama

Licensing classes are the joint effort of the Alabama Onsite Wastewater Association and University of West Alabama. Courses are at UWA Livingston campus unless stated otherwise:

- April 3-4 – Continuing Education, Pelham
 - May 6-8 – Basic Installer
 - May 13-15 – Advanced Level II Installers
- Call 334/396-3434 or visit www.aowa.org.

Minnesota

The University of Minnesota Extension has these classes:

- April 14-16 – Basic Design of Onsite Systems, White Bear
- April 17 – OSHA Competent Person/Pipelayer Certification, Sauk Centre
- April 27-29 – Introduction to Onsite Systems, Grand Rapids
- May 4-5 – Pumping/Maintenance, Mankato
- May 4-5 – Service Provider, Mankato
- May 20-21 – Soils, Owatonna
- May 27-28 – Inspecting Onsite Systems, Waseca

Call Nick Haig at 800/322-8642 (612/625-9797) or visit <http://septic.umn.edu>.

Missouri

The Missouri Smallflows Organization is offering these continuing education courses:

- April 21 – Troubleshooting, Moberly
 - April 22 – Hydraulics, Moberly
 - May 5 – Basic Drip Irrigation Design and Installation, Chillicothe
 - May 6 – Onsite Pumps, Panels, and Electrical, Chillicothe
 - May 19-20 – Operation and Maintenance, Liberty
- Call 417/739-4100 or visit www.mosmallflows.org.

Virginia

The following courses by the Virginia Onsite Wastewater Recycling Association and Virginia Center for Onsite Wastewater Training are at Blackstone unless stated otherwise.

C A L E N D A R

March 1-4

Ontario Onsite Wastewater Association Conference and Exhibition, Sheraton Conference Centre, Richmond Hill. Call Denis Orendt at 905/372-2722 or visit www.oowa.org.

March 3-4

Texas On-Site Wastewater Association Conference, Waco. Call 888/398-7188 or visit www.txowa.org.

March 8-10

Pennsylvania Association of Sewage Enforcement Officers Conference, Grantville, Pa. Call 717/761-8648 or visit www.pa-seo.org.

March 17-19

California Onsite Wastewater Association Exhibition and Technical Conference, Arden West Hilton, Sacramento. Call 916/727-2692 or visit www.cowa.org.

March 23-24

Tennessee Onsite Wastewater Association Continuing Education Workshop and Annual Meeting, Embassy Suites, Murfreesboro Hotel and Conference Center. Call 615/890-4464 or e-mail Theo Terry at theo.terry@bearonsite.com.

April 3-4

Alabama Onsite Wastewater Association Annual Trade Show, Pelham Civic Complex, Pelham. Call 334/396-3434 or visit www.aowa.org.

April 6-9

National Onsite Wastewater Recycling Association Technical Exhibition and Conference, Midwest Airlines Convention Center, Milwaukee. Call 800/966-2942 or visit www.nowra.org.

- April 15 – Proprietary System Training (VOWRA)
- April 23 – A to Z of Onsite Wastewater, Fredericksburg (VOWRA)
- May 13 – Proprietary System Training (VOWRA)
- May 13-14 – Wastewater 101 (VCOWT)

For VCOWT classes, contact Debbie Campbell at 434/736-2011 or visit www.southside.edu/programs/wastetreat. For VOWRA courses, contact Jeff Barr at 703/771-5250 or visit www.vowra.org.

Washington State

The Washington On-Site Sewage Association and Washington State Department of Health, in cooperation with Washington State University, offer these certification courses at the training center in Puyallup.

- April 8 – Maintenance Basics
- April 15 – Pumper 101
- April 22 – Designers: Subsurface Drip Systems
- May 6 – Basics of Electrical
- May 7 – Control Panel Wiring
- May 13 – Mounds and Sand Filters
- May 20 – Maintenance Basics, Bremerton

Call WOSSA at 253/770-6594 or visit www.wossa.org.

Pumper invites your state association to post notices and news items in this column. Send contributions to editor@pumper.com. ■

The Clear Choice!



Engineers through the country are specifying the PL-525 for commercial and residential applications. The PL-525 extends the time between servicing with its patented shut-off ball and ability to accept a Smart Filter® Alarm. Our vast selection of accessories will help you in any application you come across. You will have piece of mind when you design or install a system with one of our filters inside. See for yourself why Polylok and Zabel are The Clear Choice!



See our complete line of Effluent Filters at www.polylok.com



3 Fairfield Blvd,
Wallingford, Connecticut 06492
1-800-701-3942 Fax: 203-284-8514
email: sales@polylok.com
Web site: www.polylok.com

You Built It... ...You Name It!

YOU TALKED...WE LISTENED

Four years of your feedback inspired the design of our new portable restroom unit. So, we'll ask you for your input again...

What should we name it?

Visit www.polyjohn.com

to submit a name for our *new* portable restroom unit.

If your idea is selected

...you win one!



New from PolyJohn

- Durable
- Stylish
- Roomy
- Easy to Maintain
- Affordable

Innovative Products ~ Knowledgeable People



there when you need us
www.polyjohn.com
800.292.1305

\$379 PolyJohn's NEW Portable Restroom Unit*

KNOCKOUT PUMPER SHOW SPECIAL

If you did not make it to Louisville, you can still take advantage of our special offer on our newest product!

*Price does not include assembly, freight, or applicable taxes. F.O.B. Whiting, IN

Offer expires 4/30/09

800-292-1305 • polyjohn.com



/// PRESVAC

DESIGNED AND BUILT FOR PERFORMANCE

Bright Finish Aluminum Tanks

for the Septic Pumping Industry...
Standard tank models from
2,000 gallons to 5,000 gallons.



Hydro-Trencher

5300 CFM air flow/28" HG vacuum with 8" hydraulic actuated boom, 3000 U.S. gal. stainless debris tank, 1000 U.S. gal. stainless water tank, 9 G.P.M. water pump with pressures to 5800 p.s.i.

Powervac 5300 for Wet/Dry Operation

5300 CFM air flow/28" HG vacuum,
Dump chutes extended to rear of truck,
Stainless steel 316, DOT 407/412



Liquid Truck - DOT 407/412

Designed for industrial liquid applications



/// PRESVAC

4131 Morris Drive
Burlington, Ontario, Canada L7L 5L5
Fax: 905-681-0411

Nationwide Sales & Service
905-637-2353 • 800-387-7763
www.presvac.com