

DEDICATED TO THE LIQUID WASTE INDUSTRY

Pumper

December 2008 www.pumper.com \$5.00 U.S.

TEAM BUNDY

Friends and family ensure success

PAGE 28

Waste In, Water Out

It's a Rocky Mt. success story

PAGE 54



2009 EXPO

Education Edge

Learn and prosper through seminars

PAGE 34

COLE PUBLISHING INC.
1720 MAPLE LAKE DAM RD.
PO BOX 220
THREE LAKES WI 54562

CHANGE SERVICE REQUESTED

PRSTD STD
U.S. POSTAGE
PAID
PERMIT NO. 411
Beaver Dam, WI



YEAR END CLEARANCE!

Year End Tax Breaks Along With Exceptional Pricing Makes The Remainder
Of 2008 A Great Time To Buy A New Septic Or Restroom Service Vehicle
From Satellite. Call Today For Pricing On Remaining '08 Inventory!



950



1600



1250



800 P & D



2500 PETERBILT



3600 PETERBILT



Imagine The Possibilities

www.satelliteindustries.com

800-328-3332

Masport®



HXL400WV Plug & Play
400 CFM
Best in Liquid Cooled



RB-DV 65 Plug & Play
912 CFM
New Evolution in Pumping

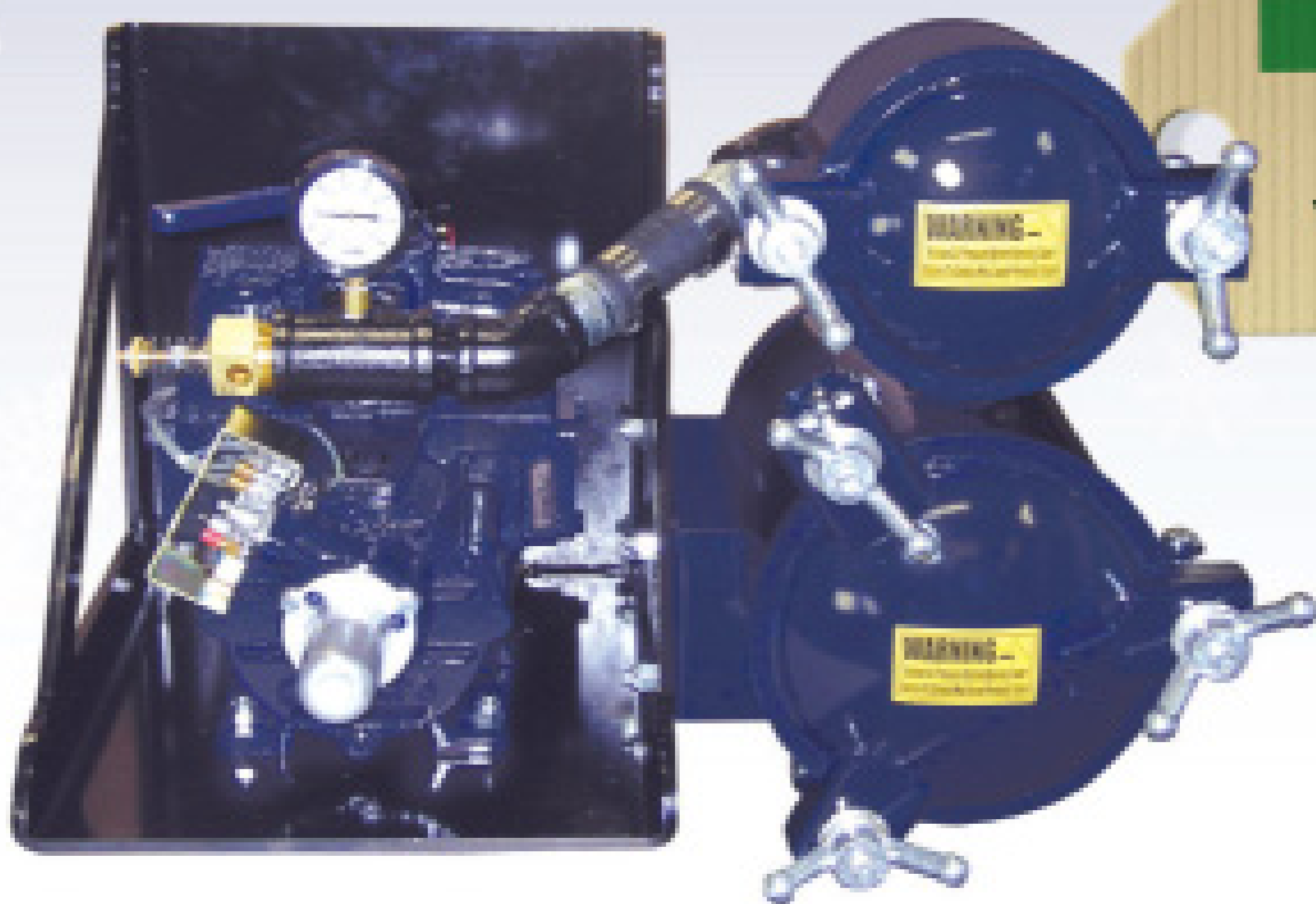

HXL4V Plug & Play
160 CFM
The Leader in Porta-Potty Pumping



RB-DV 45 Plug & Play
494 CFM
Quick & Easy to Install

The Perfect Christmas Wish List

Discover how Plug & Play Systems can save you time and money.



1-800-228-4510

www.masportpump.com

Happy Holidays and Season's Greetings
from your friends at Masport.

Bringing Home the Bacon Grease



By Jim Kneiszel, Editor

This time every year, I enjoy reviewing the *Classy Truck* winners published in *Pumper* over the past 12 months. It's a pleasure to take another look at the service trucks that graced these pages and be reminded of the blood, sweat and tears that go into building each and every one.

I gather photos of the dozen vacuum tank carriers for our annual *Classy Truck of the Year* contest, which is promoted in these pages. I'm always struck at the attention to detail paid by the owners of these trucks. They create long spec sheets spelling out the features they want on the vehicles that help them earn a living. Some of the trucks are restored to past glory, while others are bought spanking new from a chassis dealer and built out by a tank maker.

These trucks are the most important and most costly tool of the pumping trade. And the owners exhibit a great deal of pride in their rigs. Whether it's through meticulous matching of the right pump to tank and right power-to-weight ratio, *Classy Truck* owners prove they're knowledgeable about the industry. By their choice of paint schemes, bold graphics and heavy use of chrome, they also show that appearance matters in this business.

And as I see from the entries that cross my desk, there's an intriguing personal story behind just about every *Classy Truck*. Sometimes the new rig is the culmination of a pumping career — the dream truck its owner has always wanted to build, but now has the means to follow through on.

Sometimes an owner dedicates a new truck to the father or grandfather who got him into the pumping game so many years ago. Sometimes a truck with all the bells and whistles is a statement about the optimism of a young business owner who's determined to succeed.

One unique story this year came from James Dillard of Dillard's Septic Service, Annapolis, Md. Dillard chose to rebuild his first-ever vacuum truck, a 20-year-old Chevy C70 from Lely Mfg., which had been destroyed in a rollover crash. (Included here is a "before" photo of Dillard's truck. Turn inside to our *Classy Truck of the Year* roundup to see what it looks like now).



I commend all of the pumpers who've sent in *Classy Truck* submissions over the past year. Their emphasis on professional appearance helps raise the reputation of the entire industry. If you know any of the pumpers on this year's contest list, give them a call and congratulate them for their efforts. And if you're planning to build a new truck this year, consider dropping me a line and sending a photo for consideration in 2009.

And don't forget to vote for your favorite *Classy Truck*. After you look over the entries, take a moment to go to www.pumper.com and cast your ballot. Just like the last two years, we'll drive the 2008 *Classy Truck of the Year* onto the cover of our February 2009 issue, to be distributed at the Pumper & Cleaner Environmental Expo International in Louisville. ■

Contact us: Pumper strives to serve the liquid waste industry with interesting and helpful stories. We welcome your comments, questions and column suggestions and promise a prompt reply to all reader contacts. Call 800/257-7222; fax 715/546-3786; e-mail Pumper editor Jim Kneiszel at editor@pumper.com.

Sanitation Station

No out of pocket expense
Immediate revenue generation
New product to your rental fleet without a major investment

Three business model offers with the Sanitation Station are:

OPTION 1
 • You buy it!
 • You rent it!
 • You pump it!

OPTION 2
 • You have a six month minimum rental...
 • We rent the unit to you at a discounted rental rate...
 • You mark the unit up and re-rent it to your customer...
 • You enjoy the revenue from pumping the unit...

OPTION 3
 • You have a six month minimum rental...
 • Call DropBox and we land the business for you...
 • We rent the unit to your customer...
 • You enjoy the revenue from pumping the unit...

DROP BOX

1.888.388.7768
www.dropboxinc.com

Booths 7174 & 7175

Lenzyme

Solutions for all Waste & Grease Problems

BOOTH 6151

Want a GREAT Gift from Santa Lenzyme ~ Call Today!

BEST PACKAGING - BEST PRODUCTS - BEST PRICE

Discover Marketing Secrets to More Pump-Outs

1-800-223-3083
Call Today for Your FREE Sample

ROOTX

Trap-Cleer

Lenzyme

HOUSE OF IMPORTS **TRUCK SALES**

▶▶ SINCE 1947

CALL ANGEL AT:
786.258.3384
OR
305.691.4778

▶▶ WWW.HOUSE-OF-IMPORTS.COM

\$90 DOWN, \$90 PER MONTH 'TIL 2009*

*WITH APPROVED CREDIT



**IN
PROGRESS**

2002 INTERNATIONAL
450 H.P. - 10 SPD. - 3000 GAL.



**IN
PROGRESS**

2002 FREIGHTLINER
500 H.P. - 280K MILES - 4000 GAL.



2003 PETERBILT 379
475 H.P. - 10 SPD. - 4000 GAL.



**IN
PROGRESS**

2003 INTERNATIONAL
370 H.P. - 10 SPD. - 2000 GAL.



2006 MACK GRANITE
THANKS TO TOM DUKE

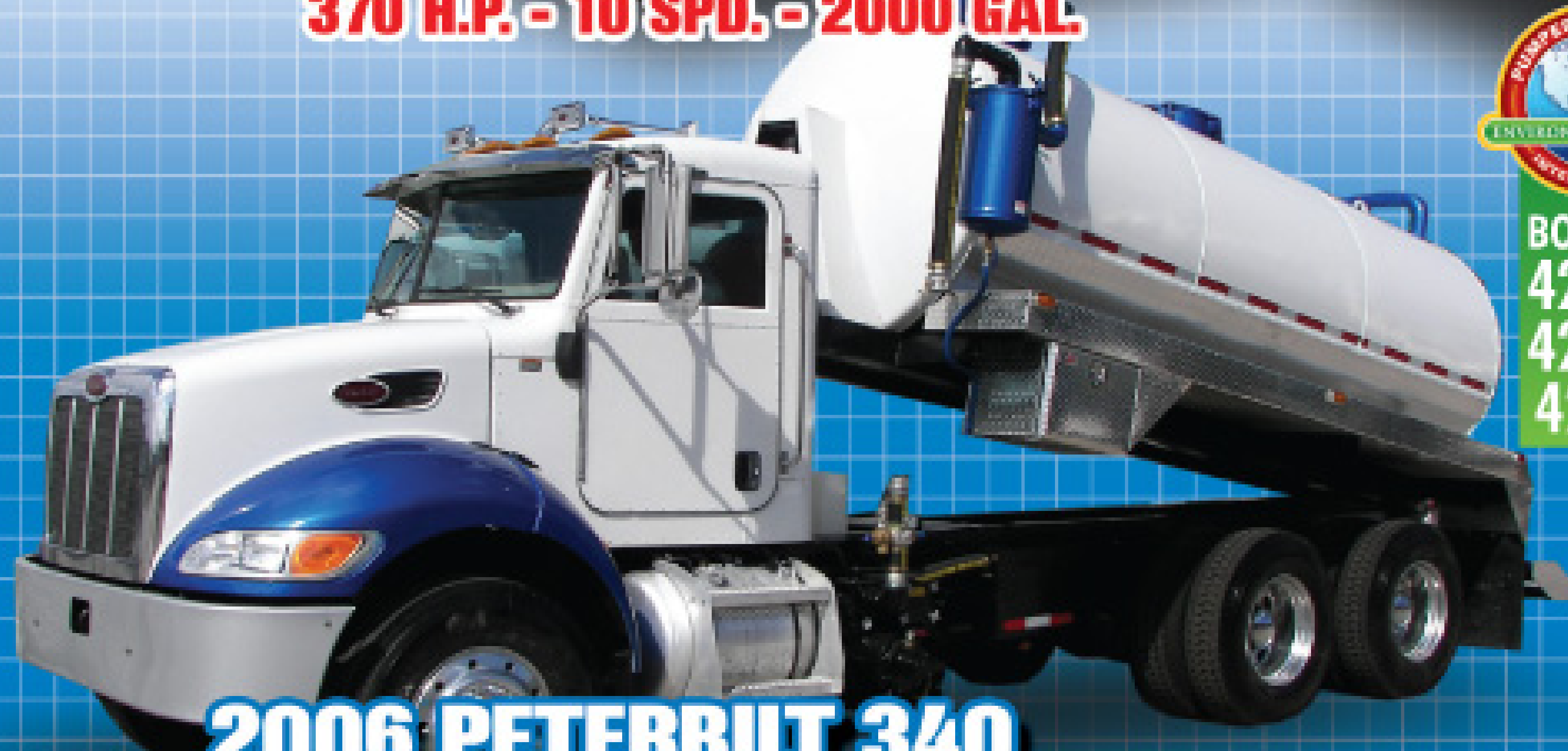

2006 PETERBILT 340
THANKS AGAIN TO JERRY THOMAS



2001 PETERBILT 385
THANKS TO DON

100,000 MILE LIMITED FACTORY WARRANTY

▶ DELIVERY ▶ EXPORT ▶ PUMP WARRANTY: 1 YEAR ▶ TANK WARRANTY: 5 YEARS



ARTICLES

- 28**
Team Bundy
- Scottie Dayton
On the cover: Brad Fischer, owner of Bundy's Sewer & Drain Service in Jericho, Vt., cleans a grease trap at a local restaurant. Fischer believes in building his business through personal service. (Photo by Andy Dubak)
- 4**
**Reading Between the Lines:
Bringing Home the Bacon Grease**
- Jim Kneiszel
- 14**
**Building the Business:
Is it Time for a Board of Directors?**
Your business may benefit from a committee of business experts paid to offer new and fresh perspectives.
- Mike Cooper
- 20**
**Rules and Regs:
Idaho Raises Minimum Size for Septic Systems**
- Scottie Dayton
- 34**
2009 EXPO: The Education Edge
Seminars during the 2009 Pumper & Cleaner Expo focus on septage disposal, private treatment plant business plans and other topics of interest for liquid waste professionals.
- Jim Kneiszel
- 38**
2008 Classy Truck of the Year
Cast your ballot soon for the best-looking truck from a garageful of 12 top rigs.
- Jim Kneiszel
- 46**
Tool Rules
Ergonomics should play a role in choosing the right hand tool for the work you'll perform with it.
- Paul Holstein
- 54**
Waste In, Water Out
Montana's Andersen Sewer Service augments regular septic pumping work with lucrative forest fire water service.
- Mary Shafer
- 68**
**After Hours:
Santa Claus is Coming to Town**
Longtime Illinois pumping and sewer repair contractor Danny Bland spreads Christmas cheer.
- Judy Kneiszel
- 84**
**Overheard Online:
Hold on Tight**
A poster wants to add another parking brake to his service rig as added insurance while stopped and pumping on a grade.

REGULAR FEATURES

- 76**
**Money Manager:
Closing the Books**
December is a good time to get a handle on the year's expenses and income, and to make decisions that can affect your tax liability.
- Erik Gunn
- 92**
**Reader Pipelines:
When Breaking Up is Hard to Do**
Do you prefer backflushing or a mechanical agitator to eliminate a rock-solid scum layer in septic tanks?
- Mary Shafer
- 100**
**Septic System Answer Man:
A Jobsite Tool with Real Impact**
A longtime Minnesota pumper shares the design he favors for impact probes and manhole covers.
- Roger E. Machmeier, Ph.D
- 104**
**NAWT Responds to Ohio Legislator's Criticism
of Onsite System Maintenance**
- Tom Ferrero
- 108**
Product News
- 112**
Industry News
- 121**
Classy Truck of the Month
We feature T.A. Lauritsen Septic & Drain Inc., Montevideo, Minn.
- 128**
**Association News; Training and Education;
Calendar**

Coming in January

Special Issue: Pumper & Cleaner Expo Pre-Show/Exhibit Preview

- **Building the Business:** Four ideas to provide special customer service
- **Contractor Profile:** Pennsylvania company has helped customers since the 1930s

Pumper

DEDICATED TO THE LIQUID WASTE INDUSTRY

www.pumper.com

Published monthly by

COLE Publishing Inc.
1720 Maple Lake Dam Rd.
PO Box 220
Three Lakes WI 54562

© Copyright 2008 COLE Publishing Inc.
No part may be reproduced without
permission of the publisher

In U.S. or Canada call toll-free 800-257-7222
Elsewhere call 715-546-3346
E-mail: info@pumper.com
Web site: <http://www.pumper.com>
Fax: 715-546-3786

Office hours 7:30 a.m. - 5:00 p.m.
Central Time, Monday - Friday

SUBSCRIPTION INFORMATION: A one year (12 issue) subscription to *Pumper* in the contiguous 48 U.S. states costs \$16 (24 issues for \$26; 36 issues for \$36). Subscriptions to Canada or Mexico cost \$28 per year (24 issues for \$54). Subscriptions to all other foreign countries cost \$82 per year. Subscribers are guaranteed monthly delivery of the magazine. To subscribe, send company name, mailing address, phone number and check or money order (U.S. funds payable to COLE Publishing Inc.) to the address above. MasterCard, VISA and Discover are also accepted. Supply credit card information with your subscription order.

CLASSIFIED ADVERTISING: RATE: \$1.00 per word, per month. Minimum of 20 words or \$20. All classified advertising must be PAID IN ADVANCE. **DEADLINE:** Classifieds must be received by the first of the month for insertion in the next month's edition. **PHONE-IN ADS ARE NOT ACCEPTED.** Ads may be faxed only when charging to MasterCard, VISA or Discover. Please supply all credit card information with faxed ads. Be sure to include your phone number (with area code) in your ad. Make checks payable to COLE Publishing Inc. and mail with classified ad to the address above. **CLASSIFIED ADVERTISING APPEARS NATIONWIDE AND ON THE INTERNET.** Not responsible for errors beyond first insertion.

DISPLAY ADVERTISING: Call 800-994-7990 and ask for Jeff, Jim, Kim, Winnie or Phil. Publisher reserves the right to reject advertising, which in its opinion is misleading, unfair or incompatible with the character of the publication.

CIRCULATION: Circulation averages 24,493 copies per month. This figure includes all three circulation regions (nationwide) and international distribution.

2009 PUMPER & CLEANER ENVIRONMENTAL EXPO INTERNATIONAL



Education Day:
February 25, 2009

Exhibits Open:
February 26-28, 2009

Kentucky Exposition Center
Louisville, Kentucky

www.pumpershow.com



MORO 100+ Years of Quality Innovation.

**The Next Generation to be Unveiled
Thursday, February 26 at 9:30 a.m. at
the Pumper and Cleaner Expo in Louisville.**

Don't Be Late!



Ask for a quality Moro pump from your truck builder, or call us for the dealer nearest you.

Pittsburgh, PA | 1-800-383-6304 | fax 412-269-4172 | www.morousaeast.com | moroeast@attglobal.net
St. Louis, MO | 1-866-383-6304, 636.584.8844 | fax 636-583-2044 | www.morousaeast.com | moro@charter.net

Happy Holidays

ADVERTISER index

December 2008

27th Trucks Inc.26

A

A Corp/Rooterman26



Abbott Rubber Co. Inc.62



Abernethy Welding & Repair91



Acro Trailer Company18



Advance Pump & Equip.73

Alpha Mobile Solutions20

AltumaMats Inc.26

American Machine & Tool Co. 110

Amthor International98

Anchor Graphics Inc.20

Aqua Ben Corp.111



Aqua-Zyme Disposal Sys.66



Arcan Enterprises Inc.102



ARMAL Inc.87



Armstrong Equip.35, 59, 88

Art's Truck & Equipment129

Atlanta Rubber & Hyd.109

B

Badger Vacuum Trucks70

Bandlock Corp.78

Best Enterprises Inc.53

Big Fish Environmental50

Brenlin Co. Inc.102



Bright Technologies82

C

Cadman Power Equipment...110



Cam Spray18

Cape Cod Biochemical40

Capital Partners LLC106



Capital Rubber Corp.72

Center Capital Corp.99



Chandler Equipment Inc.9, 11

Chempace Corporation90

Circle D Truck Sales96



Clear Computing Inc.105



Comforts of Home Services ..48

Control Chief82

Cromaglass Corporation42



Crust Busters/Schmitz Bros. ..15

D

Del Vel Chemical Co.70

Denver Truck Sales105

Dragon Products32-33

Drop Box Inc.4

Dunham & Morrow Inc.44

E

Ecological Laboratories48



Elastec/American Marine94

Erickson Tank & Pump43

Excel Equipment & Supply ..106

F



F. S. Solutions50

Fergus Power Pump Inc.114



Flo Trend Inc.111

Fritz Industries19

Fruitland Tool & Mfg.52

G

GapVax Inc.103

Global Vacuum Systems. ...22-23

Granite Leasing Co.72

Green Way by PolyPortables ..79

H

Hampel Corp.71

Hannay Reels10

House of Imports5

Hull's Truck Bodies86

I

Imperial Industries Inc.85

J



J&J Chemical Co.61



JAG Mobile Solutions72

James Wilbee Company Inc. ...24

K

KeeVac Industries Inc.63

Kentucky Tank Inc.96

Key Commercial Corp.90

KMH Equipment Inc.25

Kroy Industries24

L

L.C. Tanks47

L.M.T. Inc.78



Lane's Vacuum Tank Inc.44

Lely Manufacturing Inc.15

Lely Waste Solutions74



Lenzyme-Trap-Cleer Inc.4

Longhorn Tank & Trailer Inc. ...58

M



Marsh Industrial101



Masport Inc.3

McKee Technologies Inc.74

Michigan Vacuum Truck Inc. ...86

Mid-Continent Truck Sales ..113

Mid-State Tank Co. Inc.129

Milwaukee Rubber Prod.18



Moro USA East Inc.7

MyTana Mfg. Company Inc.62

N

National Truck Center94

National Vacuum Equipment ..97



NuConcepts58

P

Pat's Pump & Blower86



Pik Rite Inc.60

PolyJohn Enterprises131

Polylok Inc.130

PolyPortables Inc.16-17

Power Vac Inc.74

PowerFlo Products Inc.66

Precision Tank & Equip.110

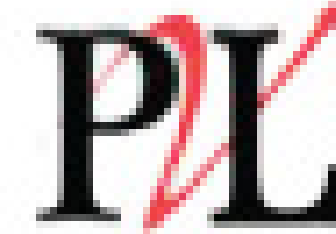

Pressure Lift Corp.21

Presvac Systems Ltd.132

Prime Solution Inc.69

Prototek Corp.70

R

Reelcraft Industries Inc.69

Rich Mobile Restrooms121



Ritam Technologies LP58

Robinson Septic Service114

RouteOptix Inc.90

Rush Refuse Systems45

S

Satellite Industries2, 64-65

Semo Tank106



Septic Services Inc.57

Simple Solutions82

Simpson/Delco42

Smithco Mfg. Inc.60

Specialty B Sales109

Spectrum Environmental121

Super Products LLC44

Surco Products89

Sweet Septic Systems Inc. ...101

T

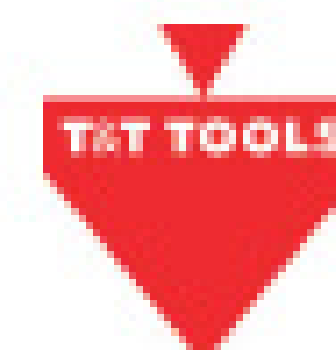

T&T Tools Inc.36

Tank Truck Service & Sales50



TankTec12-13

TEAMCO36

The Service Program110



Toico Industries Inc.95



Transport Truck Sales31



Transway Systems Inc.83

TRS Industries114

Truck Town Inc.111

Truck Works Inc.115

TSF Company Inc.77

TST, LLC67

Tuf-Tite Inc.41

V

V.E. Enterprises Inc.51

Vac-Con Inc.93

Vacutrux Limited21



Vacuum Sales Inc.49, 98



VAR Co.75

W

Walex Products Co.107

Wallenstein Pumps-Elmira ..102

Water Cannon Inc.37

Wee Engineer Inc.88



Wells Cargo COG52

West-Mark Inc.115

Westmoor Ltd.27

White River Distributors48

Wilcox Truck Sales102

Wolf Creek Co. Inc.42

Classifieds116

Marketplace122

Truck Stop124

REGIONAL ADVERTISERS

Midwest Supplement

(after page 66)

Bosserman Tank & Truck7

Engle Fabrication LLC7

Liberty Financial Group2

Marengo Fabricated Steel8

Mid-State Truck Service8

Milwaukee Rubber2

Pierson Co.2

Rider Vacuum Sales3

T-Line Equipment Inc.1

V&H Inc.1

Eastern Supplement

(after page 66)

Andert Inc.2

Bay State Truck7

Bosserman Tank & Truck7

Cellofoam1

Engine & Accessory Inc.8

GMF Associates8

Liberty Financial Group8

Manchester Hose3

Marengo Fabricated Steel2

TSI Tank Services3

V&H Inc.1

Worldwide Service

Jurop

NORTH AMERICA



**Chandler
Equipment, Inc.**



- Jurop Vacuum Pumps & Blowers
- Complete Vacuum Pump Packages
- Primary & Secondary Shutoffs
- Valves & Couplings
- Oil Catch Mufflers
- Manways
- Final Filter
- Tank Accessories

SEASON'S
Greetings



800-342-0887

www.chandlerequipment.com

You Can't Buy A Better Reel.

Hose Reels for Cleaning and Pumping

- ✓ High pressure washing and cleaning
- ✓ Sewer, septic, portable toilet cleaning
- ✓ Video pipeline inspection
- ✓ OE vehicles and aftermarket upgrades
- ✓ Extra rugged, long-lasting design
- ✓ Complete custom capabilities



Download or call for your FREE Guide to Ordering Pumper/Cleaner Reels
<http://go.hannay.com/U16>
877-467-3357

 **Hannay Reels®**
The reel leader.



*From home to home, and heart to heart,
from one place to another —
The warmth and joy of the Season,
bring us closer to each other.*

Best wishes for a healthy and prosperous 2009!

Your Friends at

 COLE publishing

Don't be amazed
 Our horizons are only a little bit wider

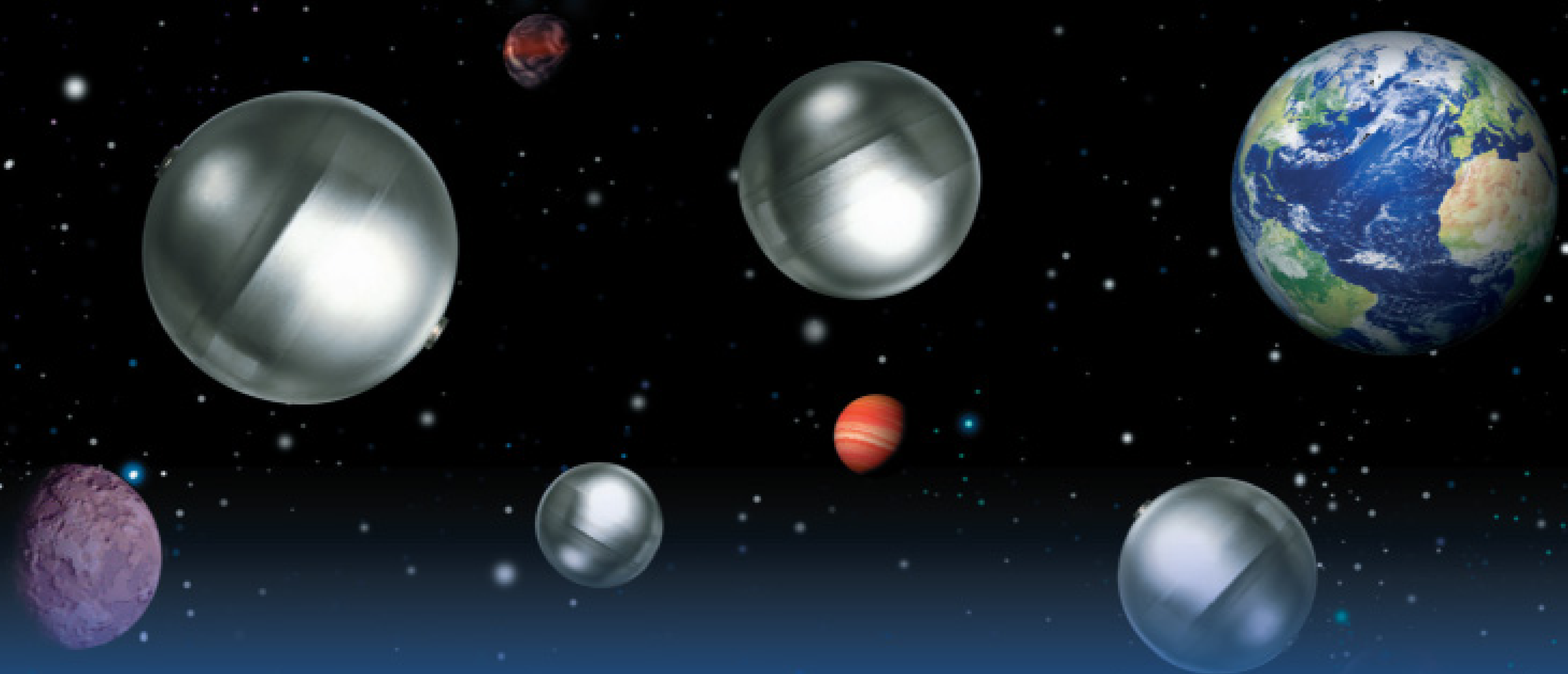

Floating stainless steel balls
 Strong, unassailable, accurate

- Available in AISI 304 and AISI 316
- Excellent spherical model
- Polished TIG welding

NEW

- DN 100
- DN 150
- DN 200

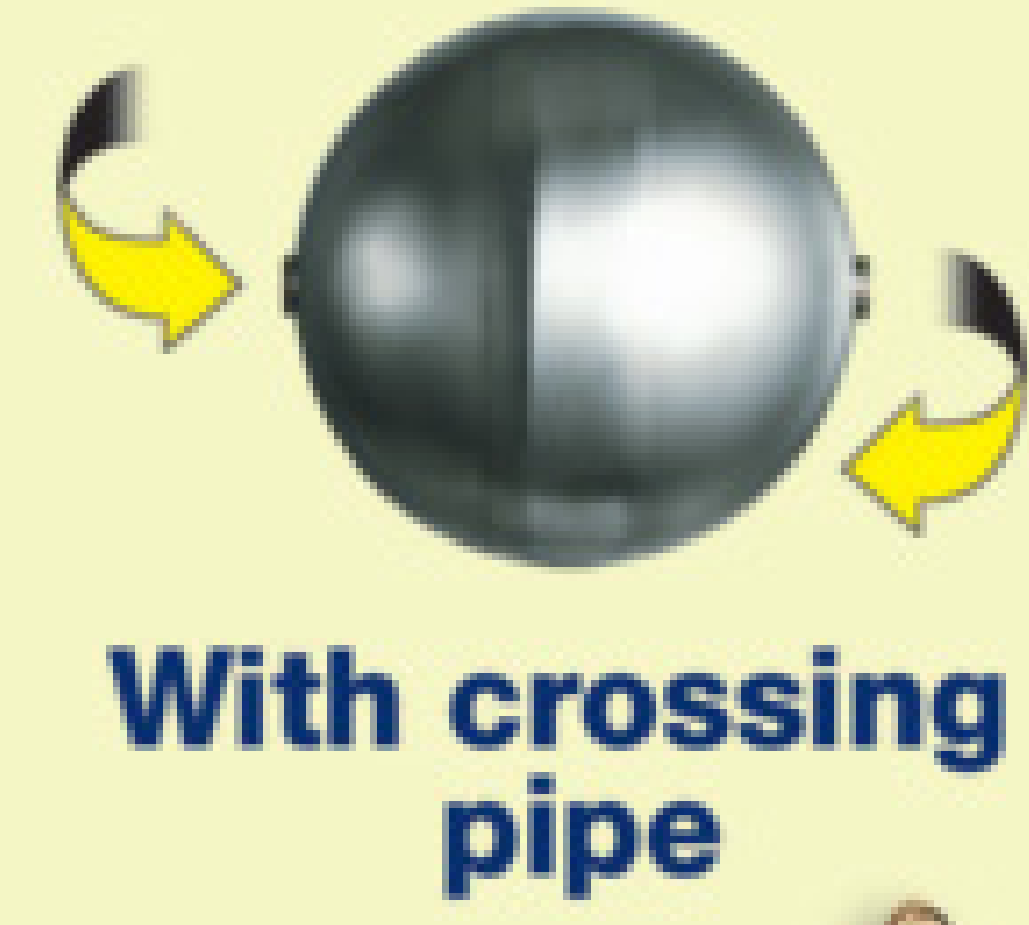

METALTECNICA s.r.l.

www.metaltecnicazanolo.com



Chandler
 Equipment, Inc.

Toll Free 1-800-342-0887
www.chandlerequipment.com

USA DISTRIBUTORS

TankTec

Tank Technologies & Supply Co. LLC
Portable Restroom Service Trucks
Septic, Grease & Grit Trucks
Refined Fuel Trucks



2008 Sterling Bullet
1250 Gallon (350/900)
\$69,999

Automatic • Hydraulic Brakes
Hydraulic Pump Drive • 19,500 LB G.V.W.

2008 Kenworth T270
1700 Gallon (400/1300)
\$77,975

Automatic • Hydraulic Brakes
22,000 LB G.V.W.



Year End Blow-Out!!!



2009 Hino 268
2000 Gallon (500/1500)
\$84,975

Automatic • Air Brakes
26,000 LB G.V.W.

Standard PRS Features:
Masport HXL4V 160 CFM
Vacuum Pump System
Burks DC-10 Water Pump
Fold Down 2 Toilet Hauler
2 Large Work Cabinets

It's Not Too Late For a 2008 Tax Deduction!

Ford, Chevy, International, Peterbilt
and Kenworth in Stock and Ready to Build.
Call for Details.

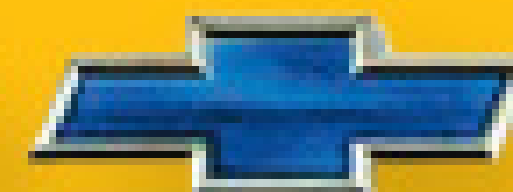

888.428.6422

2008 International 4400
3600 Gallon

\$106,245 +FET

DT466 300 HP/ 860 TQ Pre Emissions Engine
Masport HXL400WV 400 CFM
10-Speed Manual



2008 Ford F750
2500 Gallon

\$85,977

6-Speed • 33,000 LB G.V.W. • 260 HP
Masport HXL15V 350 CFM Pump System
2 Cabinets

2002 Freightliner FL112
3600 Gallon

\$84,345 +FET (Tank Only)

CAT C-10 350 HP • Masport HXL400WV 400 CFM
Red Cab • Reconditioned Chassis • New Tank &
Pump System • 2 Year Extended Warranty
9-Speed



Ask About In Stock Trucks • Call for Lease Payment Details
Tanks in Stock • Financing and Leasing Options Available • Dual-Use Options
Customize to Your Needs • PRS 800-2500 Gallon • Vacuum 1000-6000 Gallon

PORTAVAC



ALUMATANK

Tank Technologies & Supply Co. LLC • 888.428.6422 • www.tanktec.biz

Steve Nelson • snelson@tanktec.biz
Andy Nelson • anelson@tanktec.biz

Local • 763.755.8075 • Fax • 763.757.9788
10100 Quinn St. NW, Minneapolis, MN 55433

Mike Cooper is a board member for PolyJohn Enterprises Corp. He can be reached by e-mail at mike.cooper@polyjohn.com.



Is it Time for a Board of Directors?

Your business may benefit from a committee of business experts paid to offer new and fresh perspectives

By Mike Cooper

A board of directors can help jumpstart a business that needs to become more competitive.

Owning your own business means being the master of your destiny. Many people get into the liquid waste hauling and portable sanitation industries for that reason alone. So if you like making your own decisions, why in the world would you consider hiring a board of directors? The main reason is that even though you make all the decisions, you don't always have all the answers.

There are many places to turn to when you need advice on tough business questions, including the Portable Sanitation Association International, the Small Business Association, your lawyer and/or your accountant. Sometimes the best perspective on your question will come from experienced local business people who you can hire and keep available on your board.

What's more, if you run a business with one or more partners or family members, a board can provide an impartial voice to help find consensus and resolution when not everyone agrees.

While it's estimated that less than 15 percent of family businesses use a board of directors, the trend appears to be growing because considerable benefits outweigh the costs of a board.

WHO NEEDS A BOARD?

A board of directors provides stability for any business undergoing significant change or mergers. It helps break deadlocks in companies that have internal competing interests, such as partners or family members who don't always see eye-to-eye, or competing business segments such as septic or portable restroom service. And a board can help jumpstart a business that needs to become more competitive.

Rapidly growing companies or those preparing for growth may also benefit from the wisdom and experience of a board of directors, since growth often brings growing pains that need to be addressed.

ORGANIZING A BOARD

The first step in organizing a board of directors is to decide what you expect the board to accomplish and how you think they should go about it. Start by developing a mission statement that gives you — the owner, your partners, key managers, and the board members a specific outline of roles, responsibilities and expectations. Here are some roles you might expect your board to serve:

- Meet quarterly and review operating issues.
- Provide independent advice to owners or managers with consultation available as issues arise.
- Bring specific knowledge and/or experience that the company may currently be lacking.
- Provide an independent point of view to help resolve disagreements among partners, family members or key management figures.

Avoid appointing your fishing buddies, close relatives or people who want to grow their own business through more business with your company, such as your lawyer, banker or accountant. A useful board will provide unbiased opinions, not a rubber stamp to your ideas.

- Suggest ideas to enhance operations, marketing, management style and growth strategies.
- Review critical financial data and record-keeping.

APPOINT THE BOARD

Generally, the best people to appoint to a board are those who have experience related to your business and opinions you would trust. It is also important to find people with varied backgrounds to bring their own perspectives to discussions.

Many times executives who have retired are looking for a place to make a continuing contribution to business, without making a huge commitment of time. Ideally, for a portable sanitation company, you would look for people who would have some insights from your customers' point of view. Look for former construction managers, builders, former local government officials or event planners. Also consider marketing executives or sales professionals who can provide insights into developing your market profile or selling to new customers. If you know anyone who formerly owned a portable sanitation business, they could be a great resource to tap.

Avoid appointing your fishing buddies, close relatives or people who want to grow their own business through more business with your company, such as your lawyer, banker or accountant. A useful board will provide unbiased opinions, not a rubber stamp to your ideas.

If you don't know anyone who fits your criteria, try asking at the local Chamber of Commerce or SBA office if they know anyone who might be interested in assuming a position on your board. One very resourceful group is SCORE, formerly the Service Corps of Retired Executives, which is made up of active business managers and retired executives who consult as volunteers.

Interview appointees thoroughly. Find out about their work background. Ask them challenging questions to see how they respond. If candidates impress you with their thoughtfulness, they're probably a good choice.

Here are some other attributes to look for:

- Wisdom and intelligence.
- A well-respected reputation in the business community.
- Experience in one or more areas of value to your company.
- Compatibility with other board members and company leaders.

- Proven ability to lead and generate new ideas.
- Enthusiasm and sincerity.

PUT IT IN WRITING

Once you have found suitable board members, it is time to structure an agreement with them. The matter of payment can be negotiated on an individual basis. You might decide on an hourly rate, a monthly retainer that pays a fixed amount each month, or a combination of the two.

Be sure to have your lawyer draw up a contract that includes a confidentiality agreement with a non-compete clause. Your board members will necessarily learn a lot about how you run your business, so you wouldn't want them talking to your competition or starting their own sanitation business across town.

YOUR FIRST MEETING

Once you bring your board together for the first meeting, you'll want to have a firm agenda of topics in place. You'll find as you begin to work through issues facing your company, the fresh thinking of your board will be invaluable. You'll see why most large corporations rely heavily on their boards. And you'll wonder how you ever managed your business without one. ■

What's Your Opinion?

Pumper welcomes letters from readers responding to articles we publish or offering comments and opinions of interest to the industry. You can submit your letter by:

MAIL: Pumper, P.O. Box 220, Three Lakes, WI 54562
FAX: 715/546-3786 ■ E-MAIL: editor@pumper.com

All letters must be signed. Please limit your letter to 500 words or less. We reserve the right to edit all letters for length and clarity.

Agitation SAVES Aggravation!

CHOICE OF 2', 4' & 6' EXTENSIONS

Guaranteed To Mix Up Septic Tanks & Grease Traps!

High speed rotation busts the crust and removes solids right off the bottom of the tank into a total liquid form
Field tested and proven to mix a residential tank in 5 minutes or less - takes approx. 15 minutes to agitate a 5000-10,000 gallon grease trap

CHECK OUT OUR NEW INFORMATIONAL DVD
PUMPER.COM/VIDEO.PHP

Schmitz Brothers L.L.C.
PHONE 763.878.2296
FAX 763.878.2299

1.888.878.2296



CRUST BUSTERS

E-MAIL pete@crustbusters.com
WEB SITE www.crustbusters.com



ASK ABOUT OUR "BUSTER BRACKETS" FOR TRUCK MOUNTING

Save More With Lely!

Thank you
Mid East
Services



Thank you
Ryder Porto Rico

Financing Available

Steel Tanks in Stock, ready to be mounted on your truck



300 + 100 Gallon Ready to go unit that will fit in the back of your pick-up



The original Gem Jet is still the best. 2000 psi @ 15 gpm



Most efficient separator on the market



Still the most inexpensive separator on the market.

Sales Representatives

John Minnis
540-547-2463

Roy Coffey
828-312-9545



P.O. Box 789
Wilson, NC 27893 -partners in wastehandling-
E-mail: sales@lelyus.com
www.lelyus.com

252-291-7050
FAX: 252-237-7726

800-334-2763

LOOKING FOR AN



IT'S A FACT:

Well engineered, quality-built restrooms are important to the success of a thriving business – not to mention your customer's satisfaction.

When the storage yard starts to fill up with worn out, un-usable, out-of-service units, it's not hard to figure that cheap restrooms aren't such a good buy after all. And

the temporary models that looked so pretty just a few months ago are now sitting idle, costing you money and customers, too.

The advantages of Vantage. The double-walled Vantage (right) is a top-of-the-line PolyPortables' restroom. It's engineered with common sense and built rock-solid, just like the rest of the PolyPortables' models.

ADVANTAGE?



Here are the advantages:

CUSTOMER-FRIENDLY

- Look at the size of that door! Tall, wide – easy for customers to enter and exit – even with bulky work gear.
- Keystone roof lets in plenty of light. The unit is brighter and feels more spacious.

SITE-FRIENDLY

- Easy to move and handle. 8 oversize handholds, corner strap-down guides and reinforced corners with no corner molds.
- Smooth easy-to-clean interior walls

EASY TO KEEP IN ACTION

- Most of the Vantage parts are interchangeable with PolyPortables' Standard and Integra models.

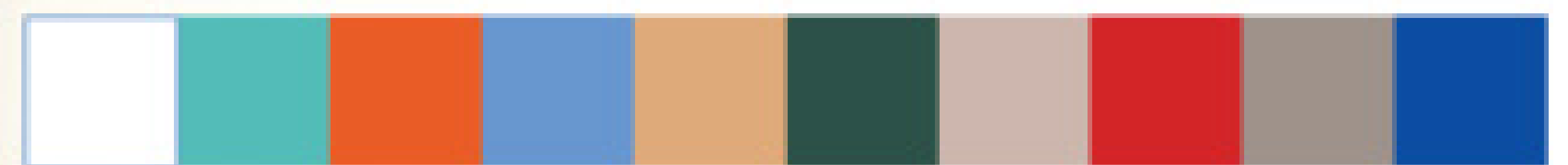

10 colors available now! Call about other available colors.

All this means you'll keep more units in the field, for longer periods of time, with less maintenance and hassle. The result: Happier customers and more money on your bottom line. Now that's an advantage!

PolyPortables: Good sense.



Listening. Learning. Delivering. Since 1972

Nothing keeps restrooms clean and fresh like Green Way Products deodorizers, cleaners and air fresheners.



99 Crafton Drive, Dahlonega, GA 30533 USA • Phone (800) 241-7951 or (706) 864-3776 • Fax (706) 864-8111 • www.polyportables.com

Manufacturing

- *Stainless Steel*
- *Aluminum*
- *Code & Non-Code*



45 Years of Manufacturing Experience

Vacuum Trailers for the
Liquid Transportation Industry

Parts • Repair • Complete Pumping Systems

800-589-5254



www.acrotrailer.com • 417.862.1758 • fax 417.862.8084 • 2320 North Packer Road • Springfield, Missouri 65803



GET MORE JETTER FOR YOUR DOLLAR!

We include all the options,
others charge extra!



4 gpm @ 3000 psi
portable JS3040
at \$2199



New Van Mount models with all
the options starting at \$8799

Trailer models
starting
at \$8299



See current models and pricing on the web or call us at:
www.camspray.com 800-648-5011

Kanaflex® 220RS Rubber All-Weather Suction Hose

SUPER FLEXIBLE IN COLD WEATHER

Call for Low Prices on 100' Lengths & Coupled Hose Assemblies

A revolutionary new method of manufacturing rubber suction and discharge hose has drastically reduced costs to hose users. The new process, ten years in development, utilizes Kanaflex SBR TYPE "T" POLYMER to give the lightweight, rubber hose outstanding flexibility and long life.

New Series 220 rubber suction and discharge hose has excellent dimensional stability and is easy to couple. Manufactured in six sizes from 1-1/2" through 6", the hose is available in 100' lengths. I.D. and O.D. are smooth. Temperature range is -40° F to 160° F – ideal for industry and construction job site use.

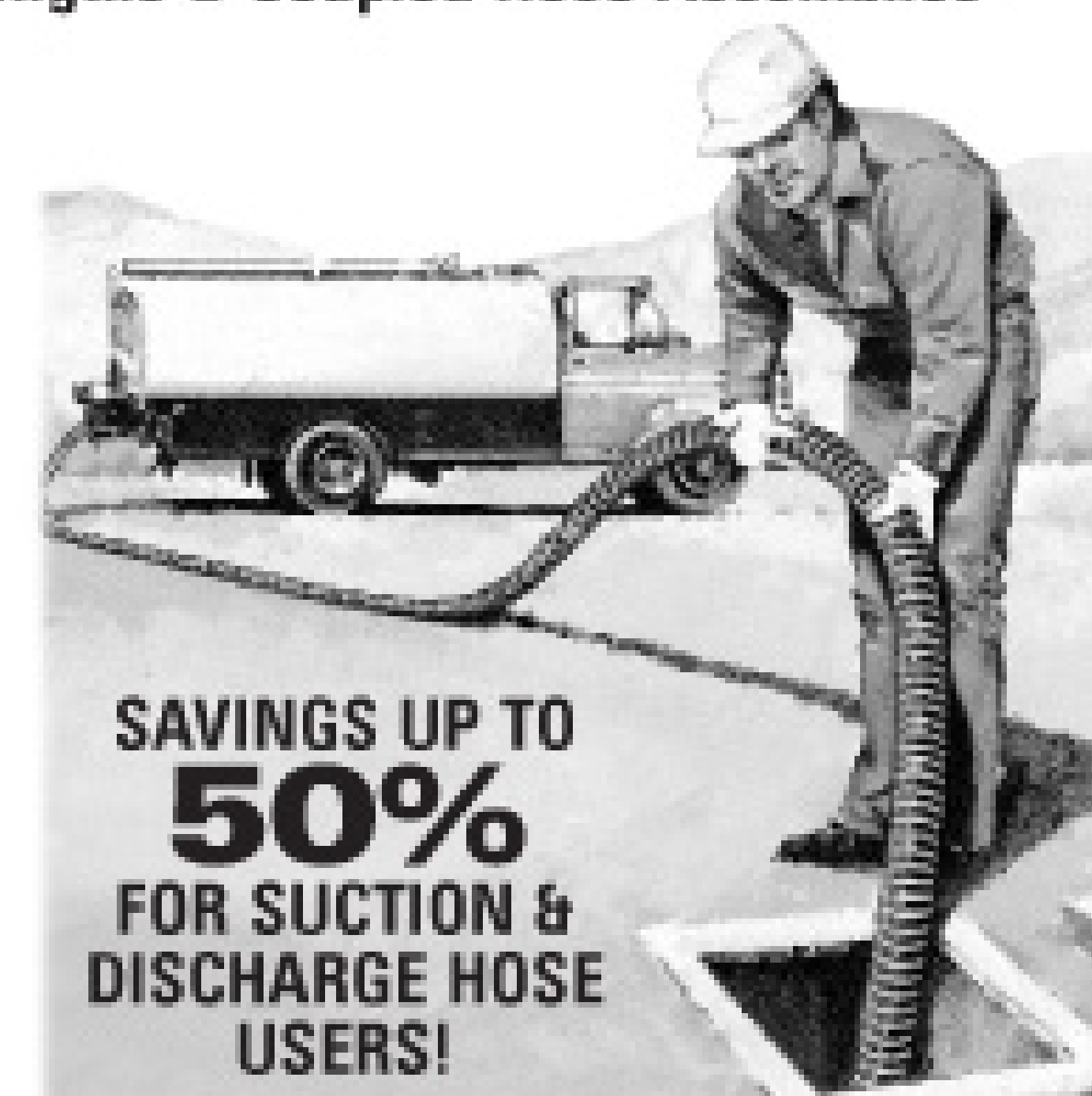

SAVINGS UP TO
50%
FOR SUCTION &
DISCHARGE HOSE
USERS!

Distributors of: **Dunlop • Goodyear • Kanaflex • Plastiflex
Hi-Vac & Other Hose • P-T & Evertite Quickcouplers
Dixon & Le-Hi Couplings • Hose Clamps • Banding Equip.**

MRP

Milwaukee Rubber Products, Inc.

Toll-Free
1.800.325.3730

www.milwaukeeerubber.com

FAX: 262.781.1742

MAILING ADDRESS: P.O. Box 451 • Butler, WI 53007

WAREHOUSE: N52 W13319 Falls Creek Ct. • Menomonee Falls, WI 53051



POSSIBLY THE FINEST, MOST EFFECTIVE SEPTIC TREATMENT AVAILABLE

SUPPLEMENT YOUR INCOME BY SELLING A PRODUCT THAT WORKS ALMOST AS HARD AS YOU DO.



FREE SAMPLE PACK

FRITZ

SEPTIC

SEPTIC TANK TREATMENT



CALL US TODAY FOR A FREE SAMPLE:

800-955-1323 x158

LIMITED TIME OFFER - WHILE SUPPLIES LAST

Fritz Industries has been producing beneficial bacteria since 1978. Each bottle of Fritz Septic Tank Treatment is packed with the same concentrated microbes and enzymes used in your local water treatment plant to break down and digest waste. Improves percolation rate through leach field and opens drain lines.

- CONCENTRATED BIOLOGICAL FORMULA
- NON-TOXIC, NO HARSH CHEMICALS
- ENVIRONMENTALLY SAFE
- DIGESTS ORGANIC WASTE
- REDUCES OXYGEN DEMAND

- IMPROVES FLOW THROUGH LEACH FIELD AND DRAIN LINES
- REDUCES MAINTENANCE COST
- LUBRICATES AND CLEANS PUMPS

Fritzbio.com

PROUDLY MADE
IN THE USA



Idaho Raises Minimum Size for Septic Systems

By **Scottie Dayton**

The Panhandle District Board of Health approved stricter onsite rules for northern Idaho. The code currently requires systems to handle 150 gpd for one-bedroom homes and 50 gallons for each additional bedroom. Under the proposal, drainfields must handle 400 gpd for three-bedroom homes.

A study by district staff of 7,000 homes found that half had undersized onsite systems. Public health experts state that Idaho's septic codes are among the weakest in the nation and must be revised because developers are turning their attention to steep slopes and places where thin soils are unable to handle wastewater. After a public hearing, the health board must decide

whether to submit the changes for legislative approval or wait another year in hopes of reaching additional consensus.

WASHINGTON

Effective Jan. 1, state rules require septic tank and gravity drainfield systems to be inspected every three years, and all other onsite systems every year. Homeowners with gravity-flow or pressurized systems may conduct their own inspections when certified through the free Homeowner Septic Training program. Alternative treatment systems must be inspected by a licensed maintenance service provider. The regulations, phased in over 18 months, also include filing homeowner inspections with the County Public Health

Department and a licensed inspection when properties are sold.

In another matter, Cowlitz County citizens objected to paying fees that would be imposed under a new septic system ordinance. The law would require onsite owners to have private contractors inspect their systems every three years, and in some cases annually. About 40 percent of the residents own onsite systems, some 10,000 septic tanks. Inspections would cost about \$125. Compliance would be voluntary.

PENNSYLVANIA

An article in the Sept. 2008 PA *Township News* reports that the state Department of Environmental Protection decided not to release simultaneously a comprehensive package of six documents that will update onsite regulations. Such an action was impossible due to DEP staff and budget limitations, and the shortage of pump-out operators and disposal facilities. The agency likely will focus on one draft document addressing site suitability and alternative analysis for new onsite systems. It includes a phased-in requirement for implementing sewage management programs based on housing density, and would allow

Rules and Regs is a monthly feature in Pumper. We welcome information about state or local regulations of potential broad interest to onsite contractors. Send ideas to editor@pumper.com.

A study by district staff of 7,000 homes found that half had undersized onsite systems. Public health experts state that Idaho's septic codes are among the weakest in the nation and must be revised.

townships to contract out their sewage management programs.

VIRGINIA

The Loudoun County Board of Supervisors voted for a five-year ban on alternative onsite systems and to impose mandatory maintenance and inspection of existing systems. The action resulted when cities said that the technologies are prone to failure, especially if owners are unaware of their operational limitations and maintenance needs. Of the 14,000 onsite systems in the county, approximately 1,200 have advanced treatment technologies. Eighteen failed shortly after installation. Fauquier County, however, is allowing alternative systems in environmentally sensitive areas. ■



Manufactured by
Forest River



Booth 11052,
11055, 11057

- Hot water heater
- A/C and heat
- 750 gal. waste tank
- 200 gal. fresh water tank
- Porcelain commodes
- Porcelain urinals
- Solid surface counter tops
- Automatic shut-off faucets
- Stainless steel sinks



CALL FOR INFORMATION OR VISIT OUR WEBSITE

(877) 789-1213

www.alphamobilesolutions.com

* WASTE LABELS & DECALS RECORDS

We Specialize in Waste Management Labeling Solutions

<ul style="list-style-type: none"> • Service Records • Lock out Tags • NRC Records • Warning Decals 	<ul style="list-style-type: none"> • Logo Signs • Gender Signs • Service Call Forms
---	--

All Printing & Signs Can be Customized at No Additional Charge



Tel: 972-422-4300 • 1-800-875-7859

Fax: 972-422-4311 • www.anchorgraphics.com

* WARNING DECALS * CUSTOM DIE CUTS * SERVICE RECORDS

POWER BOOSTER



Happy Holidays from all of us at Pressure Lift

PL Pressure Lift Corp

Pump Deeper – Pump Quicker
www.pressurelift.com

Patented Technology for Pumping

Give Yourself the Gift of **Time**...
 Add A Power Booster To
Reduce Your Time On The Job

DECEMBER DEALS

NEW ORDERS:

- Free **MAG-LITE**
- Free Shipping
- Register For The "Dinner For 2" Promo, Win A \$100 Gift Card

EXISTING POWER BOOSTER USERS:

- Join Our Direct Referral Program
- Submit A Testimonial
- Send Us Your Digital Pictures Of The Power Booster On The Job
- Customer Appreciation Discounts



ALL DECEMBER SALES BENEFIT OUR
TOYS FOR TOTS
 CAMPAIGN

972.355.0550
 Call for **FREE DVD**

We Do Industrial



DOT/TC 407/412
 code tanks available

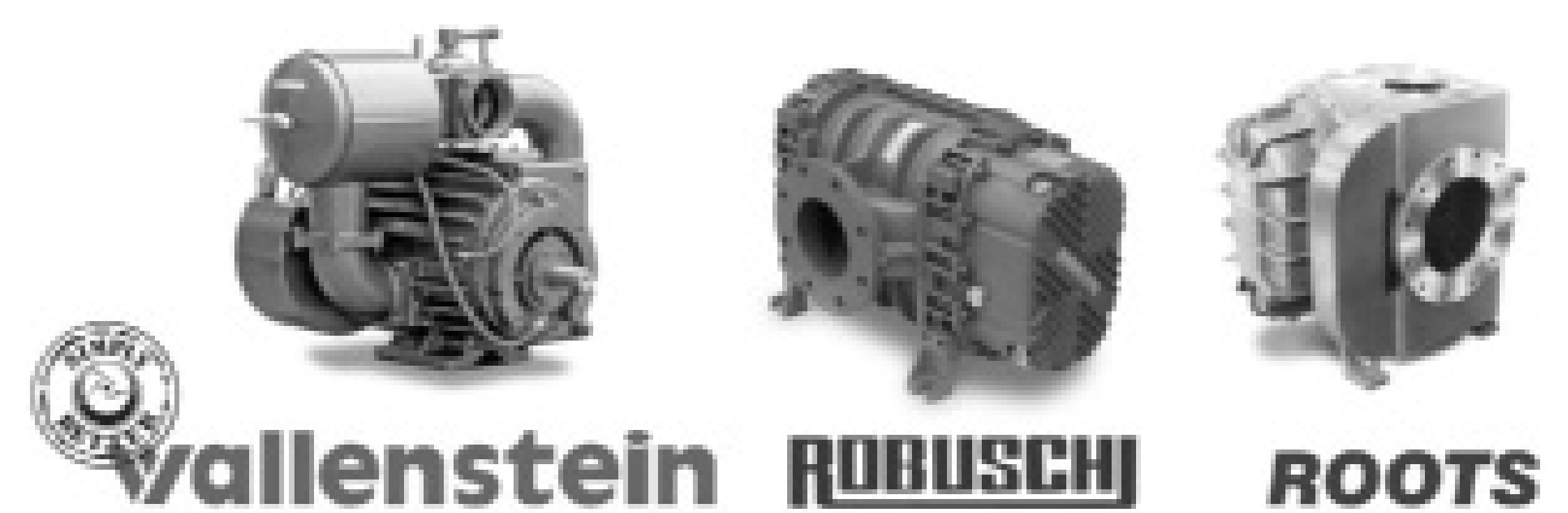

Rotary vane and
 blower packages available



vacutrux

20 Martins Ln ELMIRA, ONTARIO, N3B 2A1
 phone (800)-305-4305, (519) 669-1625
 fax (519) 669-8331 salesinfo@vacutrux.com





"Built to do the work for you."

Providing engineered solutions to meet your needs, Global Vacuum Systems, Inc. can custom-design a tank of any size to be mounted on either a new or used chassis, and with 25 years experience dealing in chassis, we can source almost any desired chassis.

Vacuum tanks are available in Code (DOT 407/412 and ASME Section VIII, Div. 1) and Non-Code, in sizes ranging from 1500 gallons (35 Barrels) to 5460 gallons (130 Barrels). Other options include tilt (with or without hydraulic assist full opening rear head), non-tilt, multiple compartments, and various pump and spray options.

Contact us to inquire about any of our available stock units, or to let us design and manufacture a custom unit to suit your needs.



New Peterbilt



2000 IHC 5600

Stock No. 1848



2003 IHC 9200

Stock No. 2001



Call for quotes



◆ New Facility ◆

Global Vacuum Systems, Inc. (GVS) recently relocated to our new facility located 6 miles south of Navasota, Texas on State Highway 6. With approximately 70,000 square feet of manufacturing and service area located on 25 acres, we feel we are better positioned to serve all your vacuum system needs.

◆ Current Inventory ◆

ASME DOT 407/412 CODE UNITS

Mounted on a new or used Peterbilt, International or Freightliner

- ◆ **New 2009 Peterbilt 340**, 14.6 Front, 40 Rear, Paccar PX-8 (300 HP), 3,000 Gal., Full Tilt/Opening, DOT 407/412, Price **\$148,723** E.E.T. Included.
- ◆ (3) Matching - **2004 CH613 Mack's**, Set forward axle, 427 engine, 10 spd., 420-440 miles, double frame, dual exhaust, 3,000 Gal., Full Tilt/Opening, DOT 407/412, Price **\$99,800**
- ◆ (1) **2003 IHC 9200**, C-15 Cat (475 HP), Jake Brakes, 18 spd, 349 miles, 3,000 Gal., Full Tilt/Opening, DOT 407/412, Stock No. 2001, Price **\$93,700**
- ◆ (1) **2001 CH613 Mack**, Set forward axle, 460 engine, 18 spd, 12 Front, 44 Rear, 211K miles, 3,000 Gal., Full Tilt/Opening, DOT 407/412, Price **\$93,200**
- ◆ (1) **2005 Freightliner Columbia**, MBE 410, Jake Brakes, Allison Auto, 200's miles, 3,000 Gal., Full Tilt/Opening, DOT 407/412, Price **\$104,200**
- ◆ (1) **2005 IHC 8600**, ISM 340 HP, 10 spd, 350 miles, 3,000 Gal., Full Tilt/Opening, DOT 407/412, Price **\$98,700**
- ◆ (2) **2000 IHC 5600**, N-14 Cummins (475 HP), Low 300's, 20 Front 46 Rear Air, 3,500 Gal., Full Tilt/Opening, DOT 407/412, Stock No. 1848, Price **\$90,000**
- ◆ (3) Used - **Full tilt/open Vacuum Truck**. Call for details.

* Tanks can be shipped.

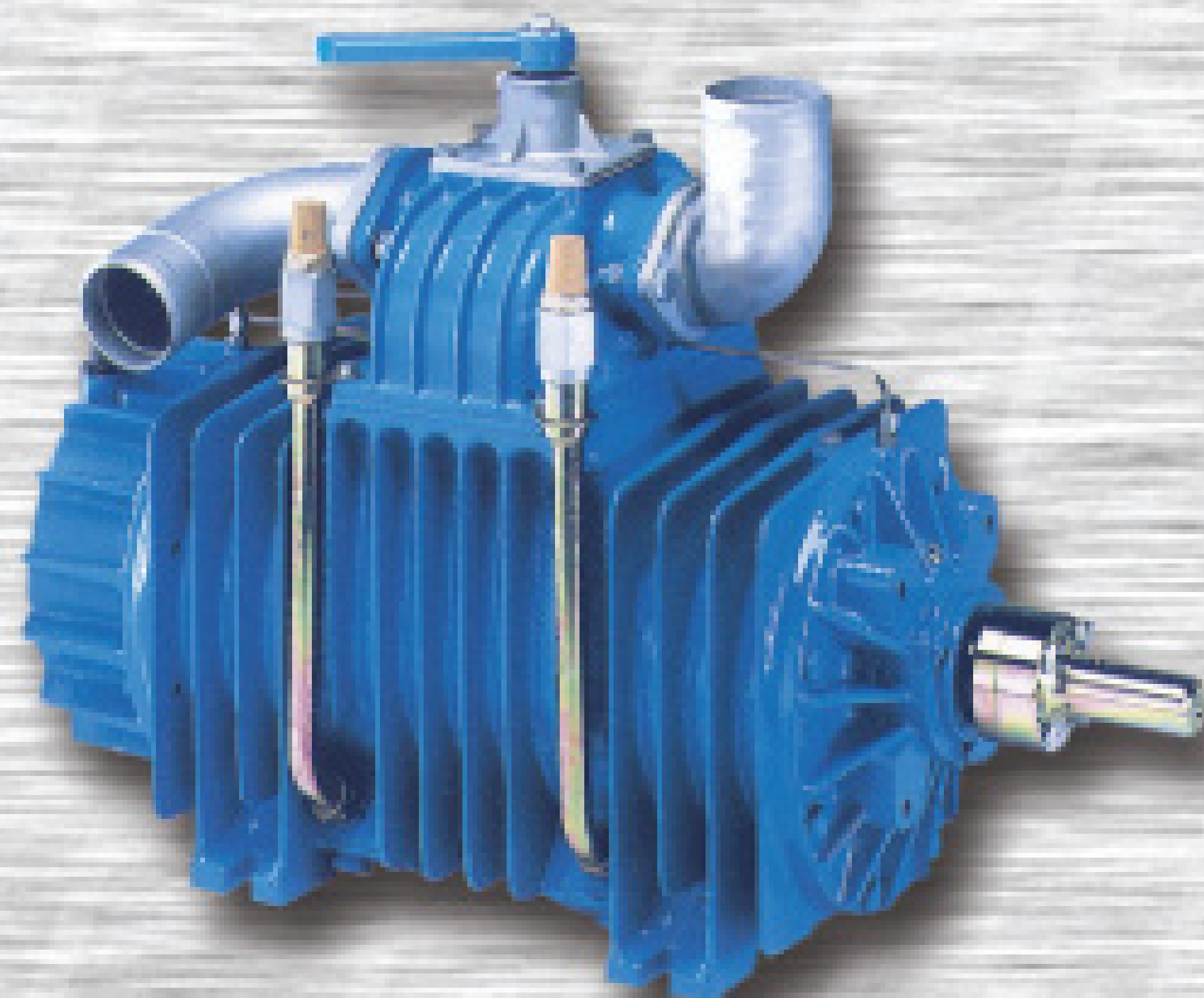

Fruitland Pumps
Jurop Pumps
Moro Pumps
Challenger Pumps

Blower Packages



- ◆ Also Available: NVE Blower packages from 500 to 1400 CFM, 28 inch vacuum with pressure capabilities



- ◆ Fruitland's Pro-Vac 500 System (includes vacuum pump, scrubber, oil-catch, gearbox, coupler, etc...) ready to bolt up and go to work.
- ◆ Optional Low Oil Sensing device, featuring an alarm or light (or both) can be installed on the oil reservoir.

MANUFACTURER OF DOT 407/412 TANKS

For more information
contact **L.C. Sutton**



Global Vacuum Systems, Inc.
15431 State Hwy 6
Navasota, TX 77868

Toll Free: 800-843-0866
Phone: 936-825-2000

Email: info@globalvacuumsystems.com
Web: www.globalvacuumsystems.com



www.kroyind.com

Kroy INDUSTRIES, INC.

We Supply

TUBING

in ALUMINUM,
STEEL or PVC



and

FITTINGS

in ALUMINUM, STEEL, GALVANIZED,
BLACK STEEL or EPOXY COATED



Kroy Manufacturing Plants

Corporate Headquarters Kroy Industries, Inc.

522 West 26th St.
P.O. Box 309
York, NE 68467
Fax: 402-362-6566
Ph: 402-362-6651 or
888-477-5769

Kroy - Olyses
626 S. County Rd. H
P.O. Box 526
Olyses, KS 67880

Kroy West
P.O. Box 1587
13400 Hanford Armona Rd.
Hanford, CA 93232

Kroy Midwest
701 S. 17th St.
P.O. Box 516
Henderson, NE 68371

MASPORT • PUMPS •

SALES • PARTS • SERVICE • STOCK

SUMMER SAVINGS ON SELECTED QUALITY MASPORT VACUUM PUMPS!



HXL20WV

Liquid cooled 410 cfm, 27" Hg. continuous vacuum

- Powerful
- Quiet
- Dependable

Masport

**CALL
TODAY FOR A
FREE QUOTE!**

WE OFFER MASPORT
FIELD-PROVEN
COMPONENTS TO
UPDATE AND IMPROVE
THE DEPENDABILITY
OF YOUR VACUUM TRUCK
OR TRANSPORT.



Masport



Masport

**NEW
SYSTEMS!**

A wide range of Masport
self-contained engine
driven vacuum pump
systems are available for
the smallest to the largest
vacuum truck or transport! •

WE STOCK AND SERVICE A COMPLETE
RANGE OF Masport QUALITY PUMPS,
COMPONENTS AND SYSTEMS!

We Put Over 40 Years of Experience to Work for You!
CALL TOLL-FREE 1-800-528-4843

YOUR AUTHORIZED MASPORT DISTRIBUTOR

**JAMES
WILBEE
COMPANY
INC.**

150 Bellam Blvd.
San Rafael, CA 94901
415-457-6880
Fax: 415-457-6930





Vac-Con V312LHAE/1300

- 2004 Sterling LT7501
- CAT C7-275HP / Allison MD 3060
- 15,870 Miles, 2350 hrs.
- 80/2000 Pump, Cummins 110HP

\$159,000



AquaTech B10

- 2004 Sterling LT7500
- 64,456 miles, 3034 hrs.
- CAT C7-275HP / 10 spd
- 80/2000 Pump, Roots 824 Blower

\$135,000



NEW

2008 VacAll AllVac AVR8

- 2007 Volvo VHD 64B
- VED12-395HP / 10 spd
- 800 gpm Sludge Pump
- Hibon 8702 Blower

\$235,000



NEW

2008 VacAll AllJetVac 1250

- 2007 Volvo VHD64F
- VE D12-365HP
- 80/2000 Water Pump
- Hydro Ex Package Available

\$225,000

**BUY EQUIPMENT
NOW FOR
2008 TAX BREAKS!**

**All Equipment
Available for Rent**



NEW

Presvac DOT 407/412

- 2009 Sterling DOT 407/412
- Cummins ISC-330HP / 10 spd
- PV750 Rotary Vane Pump
- Full open door, dump body

\$150,000



NEW

Presvac DOT 407/412

- 2009 Sterling Acterra
- Cummins ISC-330HP / 10 spd
- VTB 820 Tri-lobe Blower
- Full open door, dump body

\$165,000



RamVac Hydro-Excavator

- 2007 Volvo VHD 64F
- VE D12-365HP / 10 spd
- 27,664 Miles, 1070 hrs.
- 0-3000 PSI, 18 gpm

\$235,000

RENT ME®

LIKE ME

BUY ME

KMH EQUIPMENT COMPANY
SALES • RENTALS • SERVICE

www.kmhequip.com

1-888-KMH-0202

154 Bender Road, Marietta, Ohio 45750
Tel: 740-568-0364 Fax: 740-568-0365

8405 East 30th Street, Indianapolis, IN 46219
Tel: 317-897-4564 Fax: 317-897-4565

WORLDWIDE EXPORTERS

27th TRUCKS INC.

2 Year
Factory Warranty
on Pumps

8975 N.W. 27TH AVE. • MIAMI, FL 33147 • PH: 305.835.9030 • EMAIL: INFO@27TH-TRUCKS.COM



1999 PETERBILT

3600 Gallon Tank, Fruitland Pump RCF 500, 350 CFM.
\$51,000



2004 INTERNATIONAL 8600

CAT C12, 10 Spd, 4000 Gallon Steel Tank, Fruitland Pump RCF 500, 350 CFM. **IN PRODUCTION.**
\$78,000. Sold 1 - 2 More Available



2005 MACK VISION

10 Spd, 4000 Gallon Steel Tank, Jurop Pump LC420. **IN PRODUCTION.** **\$75,000.** Sold 1 - 1 More Available



2001 MACK

10 Spd, 3600 Gallon Tank, Fruitland Pump RCF 500, 350 CFM.
READY FOR IMMEDIATE DELIVERY! \$59,000

**\$90 DOWN AND
\$90 A MONTH
UNTIL 2009**

**5 year Factory Warranty
on Carbon Steel Tanks**



1999 PETERBILT

CAT C12, 10 Spd, 430 HP, 3600 Steel Tank,
Fruitland Pump RCF 500, 350 CFM. **\$51,000**

WWW.27TH-TRUCKS.NET

Contact Alan @ 305-457-8058, Armando @ 786-267-3026, David @ 786-236-9007

**10 Year Factory Warranty
on Aluminum Tanks**

We've Got You Covered

Whatever you need in ground protection mats

AlturMATS

Toughest mat in the industry. Supports 60 ton vehicles.

VersaMATS

Perfect for vehicle or pedestrian traffic.

Mobile Matt™

Unique waffle tread. Slightly lighter weight.

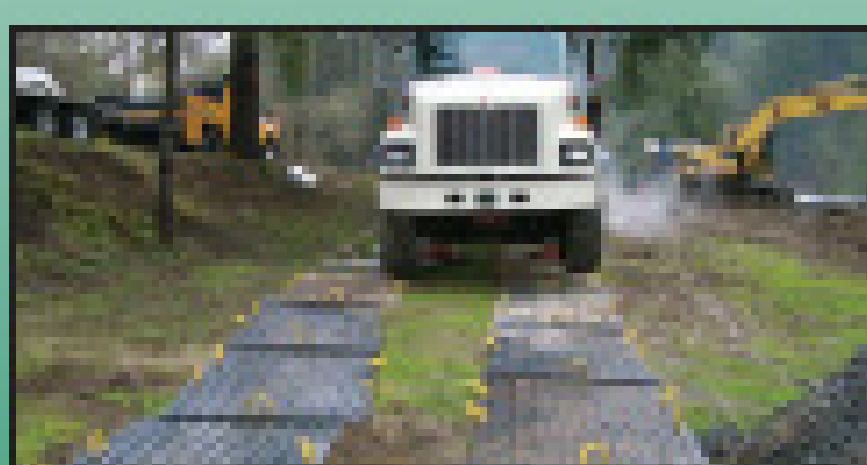

AlturMATS continues as the world's largest producer of quality ground protection mats.



One-Piece Plastic Outrigger Pads Available in a variety of sizes.

AlturMATS®

sales@alturmats.com

www.alturmats.com

Call for the name of your nearby dealer:
888-544-6287



Join The Rooter-Man Team
WWW.ROOTERMAN.COM

ROOTER-MAN®



"To The Rescue"



Booths
9015
9115

See us in Louisville February 2009



New Concept In Franchising

NO ROYALTY ON PERCENTAGE OF SALES BASED ON POPULATION

Exclusive Territories Available

Reserve your Territory, Call 1-800-700-8062

FRANCHISE PACKAGE \$7,950.

Season's Greetings



Something for Everyone

Gas Engine Units

Pumps

Grease Trap Units

Right Angle Drive Units



Wishing you a safe & Happy Holiday season

Westmoor Ltd. * PO Box 99 * Sherrill, NY 13461

800-367-0972

Fx 315-363-0193

www.westmoorltd.com



TEAM BUNDY

Family, close friends work together to achieve customer service goals and build on the success of an old-line Vermont business

By Scottie Dayton



Mike Neill (left), Brad Fischer (center) and Shawn Roberts of Bundy's Sewer & Drain Service, Jericho, Vt., auger a line at a local restaurant. (Photos by Andy Duback)

When Leon Bundy founded Bundy's Sewer and Drain in Jericho, Vt., 53 years ago, a strong back and solid work ethic were the main ingredients that built a small family business.

Today, with the help of Bundy's granddaughter, Deanna, computer technology and more efficient business systems help overcome challenges including getting the most out of a small staff and coping with rising fuel costs.

But there's one constant that the founding Bundy and current company leaders would tell you is key to their longevity in an uncer-

tain business climate: personal service provided by a close-knit team.

Maintaining a reputation for superior service, continued by Leon's son, Warren, and carried forward by daughter Deanna and her husband, Brad Fischer, has always been the goal.

When they purchased the business in 2001, Deanna and Brad Fischer faced the challenges of upgrading the office and expanding services without hiring more employees. They believe staying small enables them to keep the personal touch in service, while monitoring its quality.

"Our employees are either family or best friends, and everyone is dedicated to our customers," says Deanna Fischer.

The success of their business strategy is often confirmed by comments. Recently, a new commercial customer said that whoever he called for references, he always heard the

same response: "Bundy's, Bundy's, Bundy's." That was perfectly OK with the folks at Bundy's.

PAPER TRAIL

Deanna Fischer was a nurse's aide before working in a real estate office to gain experience. When she assumed the clerical business duties at Bundy's in 2005, everything was on index cards in a well-organized filing system. "This is the way the business ran for 26 years," says Fischer. "They never used the computers, preferring to keep the books in old-fashioned ledgers."

Profile

Bundy's Sewer & Drain Service Inc. Jericho, Vt.

Owners: Brad and Deanna Fischer

Founded: 1955

Employees: 6

Services: Commercial, residential, and industrial pumping, onsite installations, inspections and maintenance, jetting and vacuum cleaning

Service area: 50-square-mile radius covering northern Vermont

Web site: www.bundyssewer.com



VERMONT



Deanna and Brad Fischer, third-generation owners of Bundy's Sewer & Drain Service.

“WHEN THE COST OF FUEL FIRST WENT UP, THE PRICES OF OUR COMPETITORS SHOT THROUGH THE ROOF. WE RAISED OUR PUMP-OUTS \$5. THIS YEAR, WE INCREASED THE PRICE ANOTHER \$5 BECAUSE EVEN WITH GROUPING, WE WERE LOSING MONEY. WE DON’T BELIEVE IN GOUGING, BUT WE DO BELIEVE IN MAKING AN HONEST PROFIT.”

Deanna Fischer

Working with an IT specialist, Tony Fletcher, Fischer converted 1,800 active accounts to a Microsoft Access database. By the close of 2005, the database was operational. “We don’t enter a name until a customer calls, and there are thousands of index cards on file yet,” says Fischer. “Repeat business drives our company.”

The database also allowed Fischer to produce professional-looking invoices and efficiently mail cards reminding homeowners that it was time to have their septic tanks pumped. The latter, a new approach, was chosen because the company believed calling customers was equivalent to telemarketing. Waiting for people to call them worked because Vermont has an aggressive onsite maintenance public outreach program. Some towns even send letters reminding homeowners to pump their tanks or lift stations every three to four years.

About 18 months ago, the company upgraded its computers, allowing Fischer to

The Bundy’s team, on a commercial job location, includes (from left) service technicians Shawn Roberts and Mike Neill, Dianna and Brad Fischer and supervisor Todd Fischer.



change how the company advertises. Previously, they relied primarily on word-of-mouth recommendations from customers. This year, Fischer designed post cards that Idearc Media will mass mail quarterly to different areas of Vermont. The cards introduce people to the Cromaglass sequencing batch reactor that Bundy’s distributes, installs, and maintains.

Other company firsts were launching a Web site in 2006, and putting company logos on Bundy’s three Chevrolet 3/4-ton service vans. Before that, only the 1994 International with 2,000 gallon steel tank and 190-cfm Masport pump had a logo. “We also supplied the crews with company clothes,” says Fischer. The only print advertising she does is in two phone books.

Bundy’s always had 24-hour emergency service, but the calls came to Warren Bundy’s home phone, which curtailed any off-premise activities. The couple ended that situation with a 24-hour emergency paging system and cell phones. They also moved the office to their home in Jericho, and built a three-bay service garage for the vehicles.

UPDATED EQUIPMENT

In 2006, the couple bought their second pump truck, a 1997 International with 2,800-gallon steel tank and 200-gallon freshwater tank with hot water jetter. The jetter enabled the company to increase its efficiency, as frozen lines are a big issue in the northern climate. Another jetter arrived soon after for the first truck, and both have been busy ever since.

Also in 2006, the couple purchased a Tru-View camera and Tru-Tracer pipe locating system from Triple R Specialty in Jacksonville, Fla. “Three or four commercial clients asked if we did camera locating, and the price of those jobs paid for the equipment,” says Brad Fischer. “Adding jettors and camera locating have increased our commercial accounts.”

Buying the camera system was flying in the face of tradition. Warren Bundy believed experienced operators using the two, K-1500 rodder machines from RIDGID could tell if the line had a sag or a break and where it was. “He was correct,” says Brad Fischer. “The sensitivity in the cable enables my guys to locate the problem within two to three feet of its actual position.”

Within the last two years, many potential commercial and industrial customers have asked if Bundy’s was a turnkey service.

“They prefer having one company handle everything,” says Brad Fischer. “We don’t subcontract work, and that saves customers a lot of money.” Bundy’s services restaurant grease traps, schools, businesses, malls, shopping centers, developments, and condominium associations in a 50-square-mile radius covering northern Vermont. Commercial maintenance contracts account for 30



Brad Fischer (above) runs a pump hose at a commercial account location. At right, a Bundy’s vacuum truck heads to another appointment.



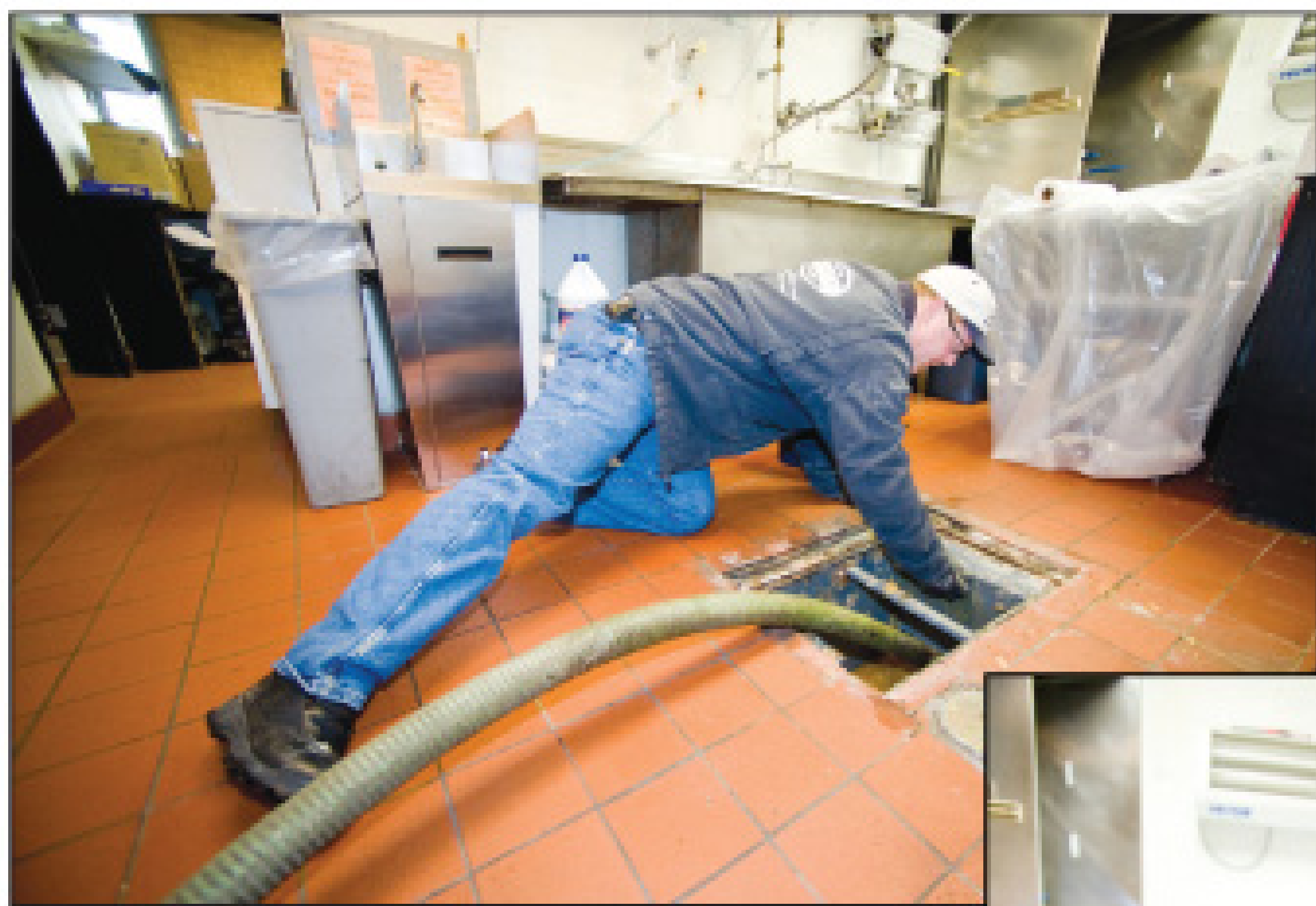

Brad Fischer (left) cleans a grease trap. Below, Mike Neill jets a line at a restaurant. Bundy's prides itself at being a one-stop shop for commercial and residential wastewater services.



"I LEARNED LONG AGO THAT A THANK YOU, OR A NOTE ON THEIR CHECKS SAYING THEY DID A GREAT JOB, OR A GIFT CERTIFICATE TO A FAVORITE RESTAURANT GOES A LONG WAY IN EXPRESSING HOW MUCH WE VALUE THEM. FAMILY MUST BE NUMBER ONE TO KEEP QUALITY EMPLOYEES."

Deanna Fischer

monthly service calls. Residential and commercial accounts are split 50/50.

Bundy's has no problem disposing of septage, but grease is another matter. Most municipal plants prefer 500 gallons of grease to be diluted with 1,500 gallons of septage. Consequently, jobs are lined up so grease tanks are pumped first, followed by one or two septic tanks or lift stations. The materials then mix on the way to the treatment plant. Vermont does not allow land application of septage.

RISING COSTS

Unless there is an emergency, Deanna Fischer groups service calls by towns or around wastewater treatment plants to compensate for the price of fuel. "When the cost of fuel first went up, the prices of our competitors shot through the roof," says Fischer. "We raised our pump-outs \$5. This year, we increased the price another \$5 because even with grouping, we were losing money. We don't believe in gouging, but we do believe in making an honest profit." For example, when pumping out neighborhoods or home associations with 10 or more tanks, Bundy's gives discounts. If customers call and a technician can't arrive until after 5 p.m., they are not charged overtime.

The couple believes that the business grew from the beginning because every customer was valued. "Customers tell us that we are

their friends, and we feel the same about them," says Brad Fischer. "For example, we had five calls this morning and the four of us knew where everyone lived. We didn't have to look up the addresses."

The four employees include Fischer, his best friend from high school, licensed journeyman electrician Mike Neil, and Shawn Roberts, who started in 1993 and has become part of the family. Todd Fischer, an identical twin brother who joined Bundy's in 2001, is responsible for onsite installations. Last year, Deanna Fischer's best high school friend, Bobbie Agan, arrived to handle scheduling, answer phones, proofread, and eventually take over many of Fischer's duties, enabling her to focus on marketing.

To show appreciation for the staff's efforts, Deanna Fischer brings pizza and soda to the men working late, and lunch if they're on a critical job.

"I learned long ago that a thank you, or a note on their checks saying they did a great job, or a gift certificate to a favorite restaurant goes a long way in expressing how much we value them," she says. "Family must be number one to keep quality employees."

Bundy's diversifies by offering sequencing batch reactors

Warren Bundy, son of the founder of Bundy's Sewer and Drain in Jericho, Vt., saw providing sequencing batch reactors as a way to expand his septic service company. In the 1960s, he became a distributor and installer for the Cromaglass system, an all-in-one system that replaces the septic and treatment tanks and produces effluent suitable for irrigation.

Daughter Deanna and her husband, Brad Fischer, who took over the business in 2001, designed seminars to inform people about the reactor. The first two-hour seminar in 2007 drew 40 installers, engineers and homebuilders.

"Attracting that many people during their busy season told us that we had a successful idea," says Deanna Fischer. "Our second seminar was in May and attracted an even higher number of participants."

Marketing plans for 2009 include participating in home shows and county fairs throughout the state. "I'm concentrating on designing brochures, doing more seminars, posting additional information about the reactor on our Web site, and renting booth space," she says.

In March, Bundy's received the Cromaglass distributorship for New Hampshire and part of New York.

Besides sick time, vacation, and health insurance benefits, the couple is looking into offering a retirement plan in 2009.

One business objective is to grow the company slowly so employees remain happy in their work. "It's knowing what we can handle and not putting ourselves in a bind," says Brad Fischer. "We want to maintain our flexible schedule, because that enables family to always come first."

The second business objective is enabling the men to retire. "My dad created an awesome reputation for the Bundy name, but he worked here until the day he died," says Deanna Fischer. "Brad and I want to see us and the other couples spend those retirement years together. Future business decisions will be made based on that goal." ■

MORE INFO:

Cromaglass
570/326-3396
www.cromaglass.com

RIDGID
440/323-5581
www.ridgid.com

Triple R Specialty
904/786-1826
www.triplerspecialty.com

TRANSPORT TRUCK SALES, INC.

Ask for **Scott or Frank** – 888-395-7551
After hours call **Scott** at 816-590-4076



What Does It Take To Be A "Qualified Chassis"?

- ✓ Pass our **12 point** checklist. (We send this out with every quote!)
- ✓ Pass a **D.O.T.** certified inspection!
- ✓ Pass the **warranty** inspection!

What Does All This Do For You?

- ✓ **Nationwide** drive train warranty for **2 years/ 200K miles!** (restrictions apply)
- ✓ A **tough** truck that is ready to work as hard as you do!

YOUR TRADES ARE WELCOME!

Searching For A **Brand New Chassis?**
We Have Them **In Stock!**



2003 Freightliner FLD11264ST, Cat C-12 410 HP, 10 spd, AC, jakes, double framed, new 3360 gallon steel vac tank, new liquid cooled Masport HXL-400 vac Pump.

Call For Pricing!

2-YEAR 200,000 MILE DRIVE TRAIN WARRANTY



2002 Mack CH613, E-7 400HP, 10 spd, jakes, AC, double framed, LOW MILES, new 3360 gallon steel vac tank, new liquid cooled Masport HXL-400 vac Pump.

Call For Pricing!

2-YEAR 200,000 MILE DRIVE TRAIN WARRANTY



2002 Freightliner FL-80, CAT 250HP, 9 spd, 33# GVW, air brakes, AC, new 2300 gallon steel vac tank, new Jurop PH-84 vac pump.

Call For Pricing!

2-YEAR 100,000 MILE DRIVE TRAIN WARRANTY



2002 Freightliner FL-112, CAT C-10 350 HP, 9 spd, jakes, 14,600# fronts, AC, double framed, new 3600 gallon Alum. vac tank, new Masport HXL-400 vac Pump.

Call For Pricing!

2-YEAR 200,000 MILE DRIVE TRAIN WARRANTY



2001 Mack CH613, E-7 300 HP, 10 spd, AC, double framed, new 3360 gallon steel vac tank, new liquid cooled Masport HXL-400 vac Pump.

Call For Pricing!

2-YEAR 200,000 MILE DRIVE TRAIN WARRANTY



1999 International 9100, Detroit 430 HP, 10 spd, AC, double framed, new 3360 gallon steel vac tank, new Masport HXL-400 vac Pump.

Call For Pricing!

2-YEAR 200,000 MILE DRIVE TRAIN WARRANTY

Delivery Available Anywhere in the Lower 48!!



DRAGON PUMPS

A Modern Group Company



Custom fabrication to meet our customers specific needs in the Petrochemical, Shipping, Drilling, Agricultural and Mining industries. All Dragon pumps, agitators, hoppers and pump packages are assembled in Liberty, Texas.

All internal pump parts such as bearings, shafts, and mechanical seals are from the highest quality parts and materials made in the USA.

We maintain a huge warehouse of motors by Baldor and Reliance and starters by Sprecher & Schuh/Allen Bradley.

We also have a full stock of replacement parts for your pumps which are 100% interchangeable with other popular pumps on the market. Dragon is the largest stocking dealer of **Fruitland Pumps and Parts** in the U.S.A.

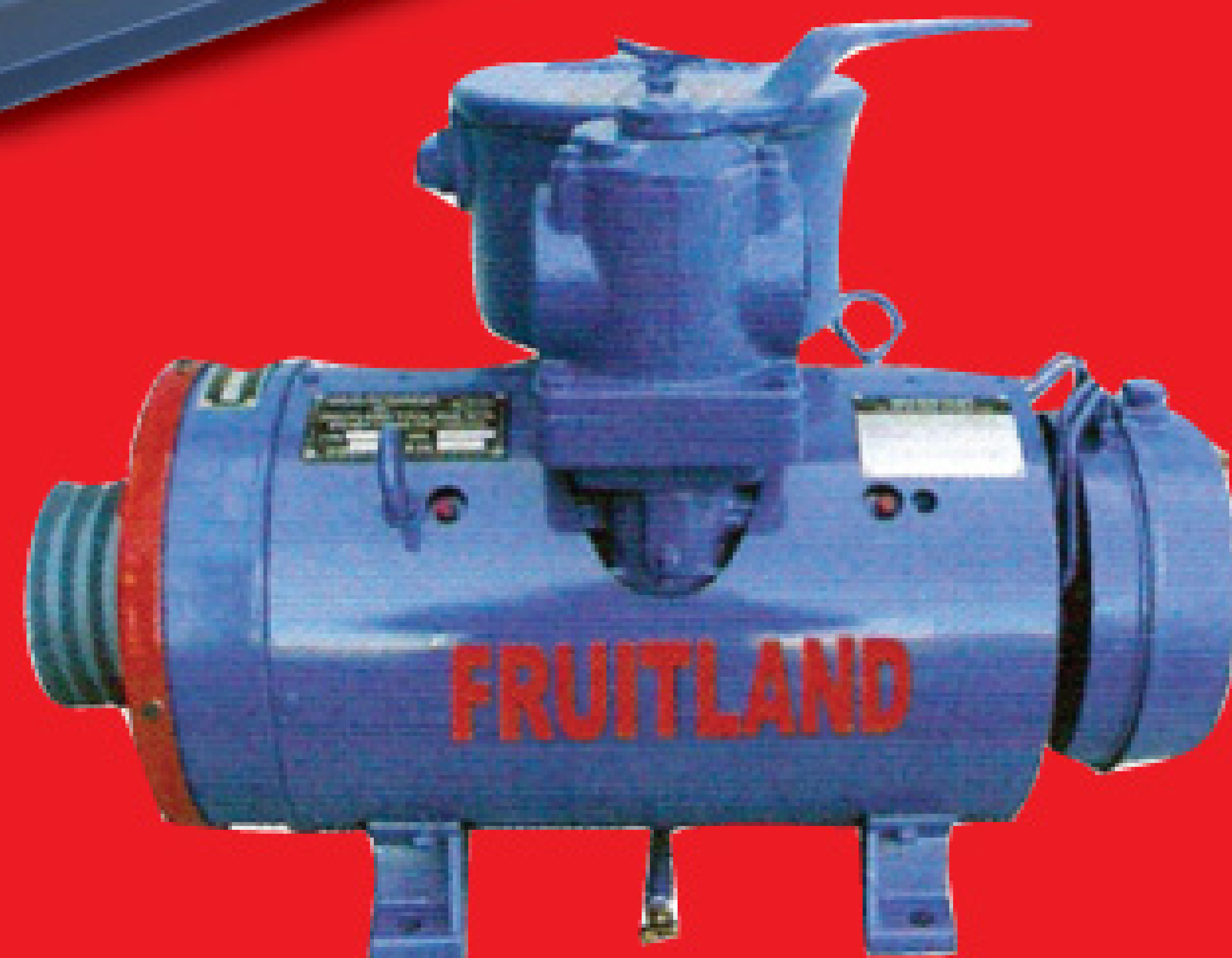

1-866-914-8198

email: sales@modernusa.com
website: www.modernusa.com

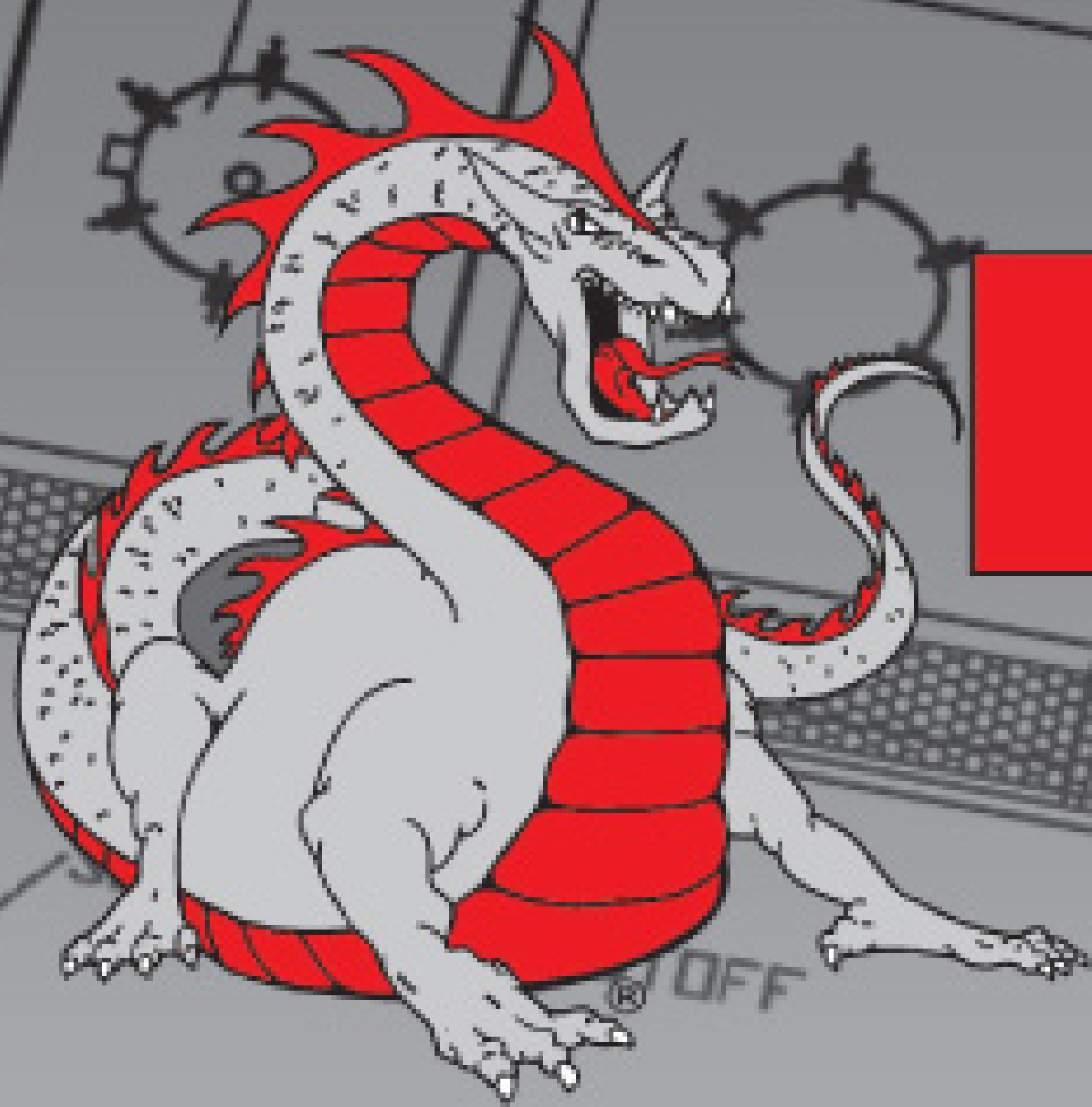

DRAGON

PRODUCTS, LTD.

A Modern Group Company



30-95 BBL STEEL & ALUMINUM BOBTAILS



150 BBL ALUMINUM & 130-160 CARBON STEEL & STAINLESS STEEL CODE AND NON-CODE VACUUM TRAILERS



500 BBL LIQUID TIGHT SMOOTH WALL CONTAINERS



VACUUM ROLL-OFF CONTAINERS

Looking for Great Deals on Quality Used Equipment.
Check out our web-site at:
www.modernusa.com

(877)778-4280

email: sales@modernusa.com



Ask about our easy Credit Terms and Convenient Financing.



THE EDUCATION EDGE

Seminars during the 2009 Pumper & Cleaner Expo focus on septage disposal, private treatment plant business plans and other topics of interest for liquid waste professionals

By Jim Kneiszel



2009 EXPO

Pumping professionals interested in exploring waste disposal options will want to plan to be on hand for a seminar track presented by the National Association of Wastewater Transporters Inc. at the 2009 Pumper & Cleaner Environmental Expo International, Feb. 25-28, in Louisville, Ky.

The NAWT program — which will navigate liquid waste haulers through many treatment and disposal choices — is part of Education Day on Wednesday, Feb. 25.

Education Day includes 46 seminars presented by industry experts across the full range of environmental service industries. Seminars also are offered Thursday and Friday mornings.

A summary of the NAWT program follows. For a complete seminar schedule, see the Expo pages in this issue of *Pumper*.

What Are My Disposal Resources and How Do They Fit?

Tom Frank, general manager for Tim Frank Septic Tank Cleaning Co., Huntsburg, Ohio

Tom Frank and his father, Tim, built a waste treatment facility from the ground up, developing an expertise with dewatering sludge and land application of septage along the way. Then the family's facility burned to the ground late in 2007 and they had to rebuild the facility. "Not only did they do it once, but they did it twice," says Tom Ferrero, executive director of NAWT. "Tom is a resourceful fellow who will give great insight into thinking outside the box" in planning a

treatment system, Ferrero says. Frank will walk attendees through the process of reviewing their current disposal options and how a pretreatment system might fit into their future plans.

Treatment Processes: What is Out There?

Therese Wheaton, owner of Crystal Environmental Springboro, Pa.

Wheaton has been a manufacturer's rep for treatment systems and is a consultant for pumpers exploring disposal options for their own businesses. While Ferrero says the Expo is a great place to see a variety of dewatering equipment, Wheaton's specialty is explaining how many components work to separate the waste stream into water that may be released to a municipal sewer system and solids that can be disposed. "She can put the big picture together and knows it as well as anyone," Ferrero says of Wheaton, who presented a private treatment plant case history at NAWT's Waste Treatment Symposium in September.

Evaluating Costs as Part of the Decision-Making Process

Tom Ferrero, executive director of NAWT

Ferrero will give advice pumpers can use to determine which method of disposal will work best in their specific situation. Choosing the best option is a first big step in business planning for the expense of a treatment system, Ferrero says. "If you can land-apply your material, there's no sense in buy-

ing a \$200,000 (dewatering) press," he notes. "If you do a business plan, it becomes very clear if one option is better than another, or it becomes clear that it doesn't matter what kind of system you go with." Taking the factors of each specific business into account, you can then choose a treatment system type and get a good idea on the costs of controlling your own disposal destiny, he says.

Meeting Part 503 Requirements

Dave Gustafson, trainer for the Onsite Sewage Treatment Program of the University of Minnesota Water Resource Center

Gustafson will explain how commingled wastes processed privately are handled under Part 503 regulations. When pumpers process septage and grease trap waste, the mix is no longer considered septage, but sewage sludge, Ferrero says. Gustafson will explain how the wastes can be dewatered and disposed of in a program he presented at the NAWT Waste Treatment Symposium. While the mixed wastes may face increased regulation, good disposal options remain, according to Ferrero.

Turn Grease Trap Waste Into Gold

Claude Convisser, president of Plant Oil Powered Diesel Fuel System Inc., Albuquerque, N.M., and Greg Jarvies, owner of American Waste Removal in Albuquerque, N.M.

Convisser and Jarvies met at the Pumper & Cleaner Expo in 2008 and forged a partner-

ship where Jarvies pumps grease traps and provides raw materials to Convisser, who skims off the oil and makes biodiesel fuel. Ferrero says it's a great arrangement to process fuel used in trucks and reduce grease disposal costs. "A couple of years ago, we said this was a neat technology, and when diesel hits \$5 a gallon, it will be valuable," he says. "We're getting closer than we think, especially when diesel got up to \$5 a gallon last summer." The New Mexico partners will explain how contractors can set up their own biodiesel operations.

Developing a Business Plan

Ron Mueller, business planning consultant for the Small Business Development Center of St. Charles County, Mo.

Mueller's specialty is explaining how small business owners can create a professional and polished business plan, which is a critical document when it comes time to seek business bank financing for a project like a treatment plant. He will help pumpers take the industry-specific technical information and insert it into a business plan that will make loan officers sit up and take notice. This program is a refined presentation of the business planning session Mueller gave at the NAWT Waste Treatment Symposium.

Liquid Waste Haulers Will Find These Additional Sessions Valuable:

Wednesday, Feb. 25 (Education Day)

- **Overview and Industry Trends: Wastewater Chemistry and Biology** – Ted Loudon, private consultant and past president of the National Onsite Wastewater Recycling Association; Mark Hooks, regional regulatory consultant, Infiltrator Systems Inc.
- **Soil and Site Evaluation Overview** – Ted Loudon and Mark Hooks.
- **Septic Tanks: Function, Inspection, Installation, and Troubleshooting** – Ted Loudon and Mark Hooks.
- **Operation and Maintenance of Systems** – Ted Loudon and Mark Hooks.
- **OSHA Regulations Need Understanding** – Kathy Romans, national sales manager for Trellborg/NPC Pipe and Manhole Repair Products Division.
- **Pumpers and O & M: Providing the Full Service** – Craig Gilbertson, environmental planner with Ayers Associates.
- **Routine Maintenance Inspections:**

Increase Profits While Lowering Cost to System Owner – Kit Rosefield, a qualified service provider in California.

Thursday, Feb. 26

- **Portable Sanitation: Maximizing Your Profits and Managing Your Costs** – Hampel Corp.
- **Selling Portable Restroom Services** – Katie Potter, Phil LaRoche and Clyde Sansom, Satellite Industries.
- **Polymer Solutions For Water and Wastewater Treatment** – Ed Winn of Fort Bend Services.

Friday, Feb. 27

- **Keys to Proper Power Take-Off Selection** – David Douglass, director of training for Muncie Power Products Inc.
- **How to Choose Vacuum Tank, Chassis and Pump Configurations** – Brian Amthor, marketing and personnel director for Amthor International.

To find out more about the education program or any other Expo offering, visit www.pumpershow.com. Register online or by calling 800/257-7222. ■

No Compromise



Don't accept a substitute for quality. The Burks DC-10 is still the most popular, high volume washdown pump available.

With flow rates to 20 gpm and pressure to 40 psig, the Burks DC-10 is the pump of choice for filling and washing your portables.

Contact your local tank manufacturer for more info, or call us toll-free at:

800-699-7557

**ARMSTRONG
EQUIPMENT
INC.**

11200 Greenstone Ave. • Santa Fe Springs, CA 90670
562-944-0404 • Fax: 562-944-3636

www.vacpump.com



T&T Tools, Inc.

Fax: 800.521.3260
Email: sales@tandttools.com



800.521.6893

www.MightyProbe.com

Call for a FREE Catalog

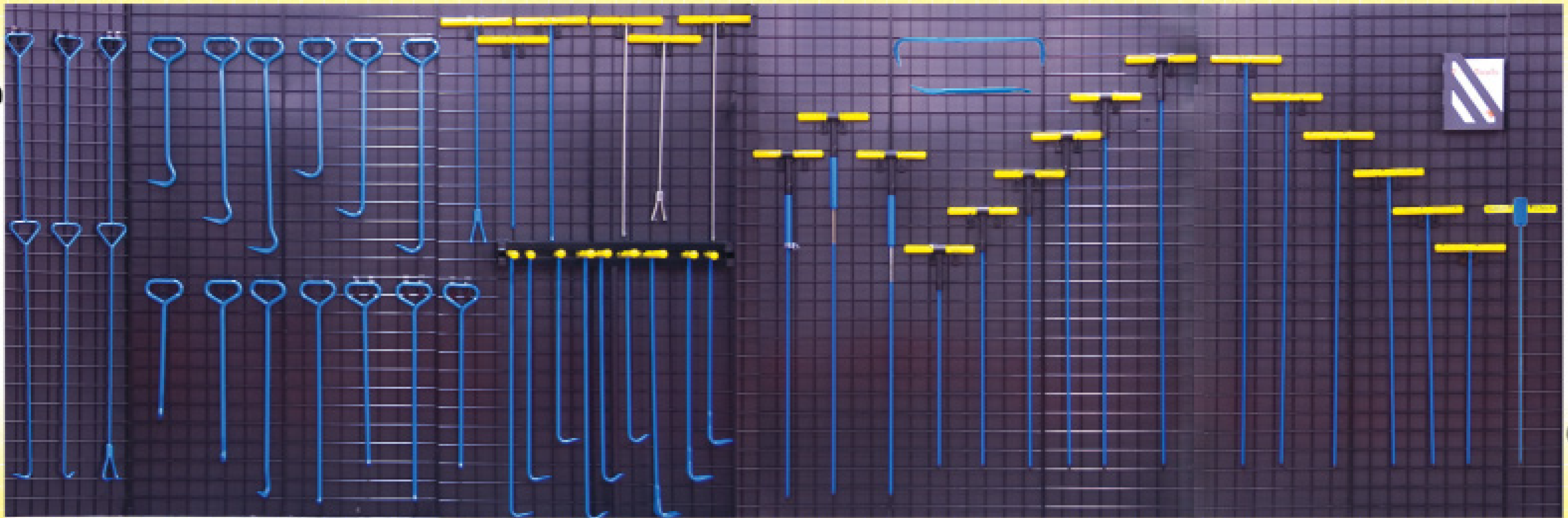

Call for a FREE Catalog

HOOKS...

- > Several different styles of heat-treated hooks are available
- > Top Poppers are great to open manhole covers
- > The Handy Hooks allow two handed use

PROBES...

- > Insulated, standard, and specialty soil probes
- > Metal shaft sizes: 3/8" round, 3/8" hex, or 7/16" hex
- > Replaceable tips are threaded on and hardened
- > A "slide" allows the handle to pound the shaft into the ground

TEAMCO™

*Depuis 1978
Since*



Alexandre Piché
Représentant, Chargé de projet / Sales representative and project manager
2, rue du Parc, Warwick (Québec) Canada J0A 1M0
Sans frais / Toll free : 1-888-358-6808 (Ext. 219)
Fax: (819) 358-2015
info@teamco.ca • www.teamco.ca

- Camion et remorque vacuum de tout genre
All Kind of vacuum trucks and trailers
- Camion séparateur de boue (pour fosse septique)
Septic sludge separator
- Cureur d'égout, combiné
Sewer cleaner, combined sewer / vacuum
- Réparation et entretien d'équipements de toutes marques
All Kind of equipment repair and maintenance
- Fabrication d'équipements sur mesure
All our units are custom built for your needs



Electric Powered Pressure Washers are Efficient & Quiet.
Industrial Applications Include: Restaurants, Factories & Drain Cleaning

Electric Powered - Hand Carry



- *UPS-able
- *Aluminum Frame
- *Jetter Capable
- *Thermal Protection
- *Fully Rebuild-able
- *Attachment Kits Below
- *We Customize
- *Single Phase

Shown with EZ Start & Duraview Filter Options

Electric Powered - Portable



- *UPS-able
- *Compact & Powerful
- *Simple to Operate
- *Light Weight
- *Cool Deck Frame
- *Low Vibration
- *15 Point Inspected
- *Single Phase

Portable Indoor Jetter Capability

We Use American Made Motors!

Part # 11E61
TT Series
2GPM @ 1200PSI
1.5HP - 115VT - 13 Amp
\$614

Part # 11E63
TT Series
2GPM @ 1500PSI
2HP - 115VT - 18 Amp
\$639

Part # 11E65
TT Series
3GPM @ 1500PSI
3HP - 230VT - 12 Amp
\$645

Part # 11E12
TT Series
2GPM @ 1200PSI
1.5HP - 115VT - 13 Amp
\$669

Part # 11E15
TT Series
2GPM @ 1500PSI
2HP - 115VT - 18 Amp
\$689

Part # 11E18
TT Series
3GPM @ 1500PSI
3HP - 230VT - 12 Amp
\$799

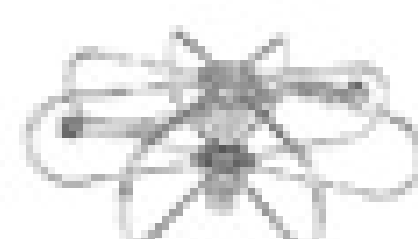

Mosmatic Duct Cleaners Available From:
3" to 24" With a Full Compliment of Accessories
See: www.watercannon.com

1-800-964-9274

Shop Online
www.watercannon.com
or Call for Fast, Friendly Service

Electric Powered - 230 Volt Single Phase - American Made Motors

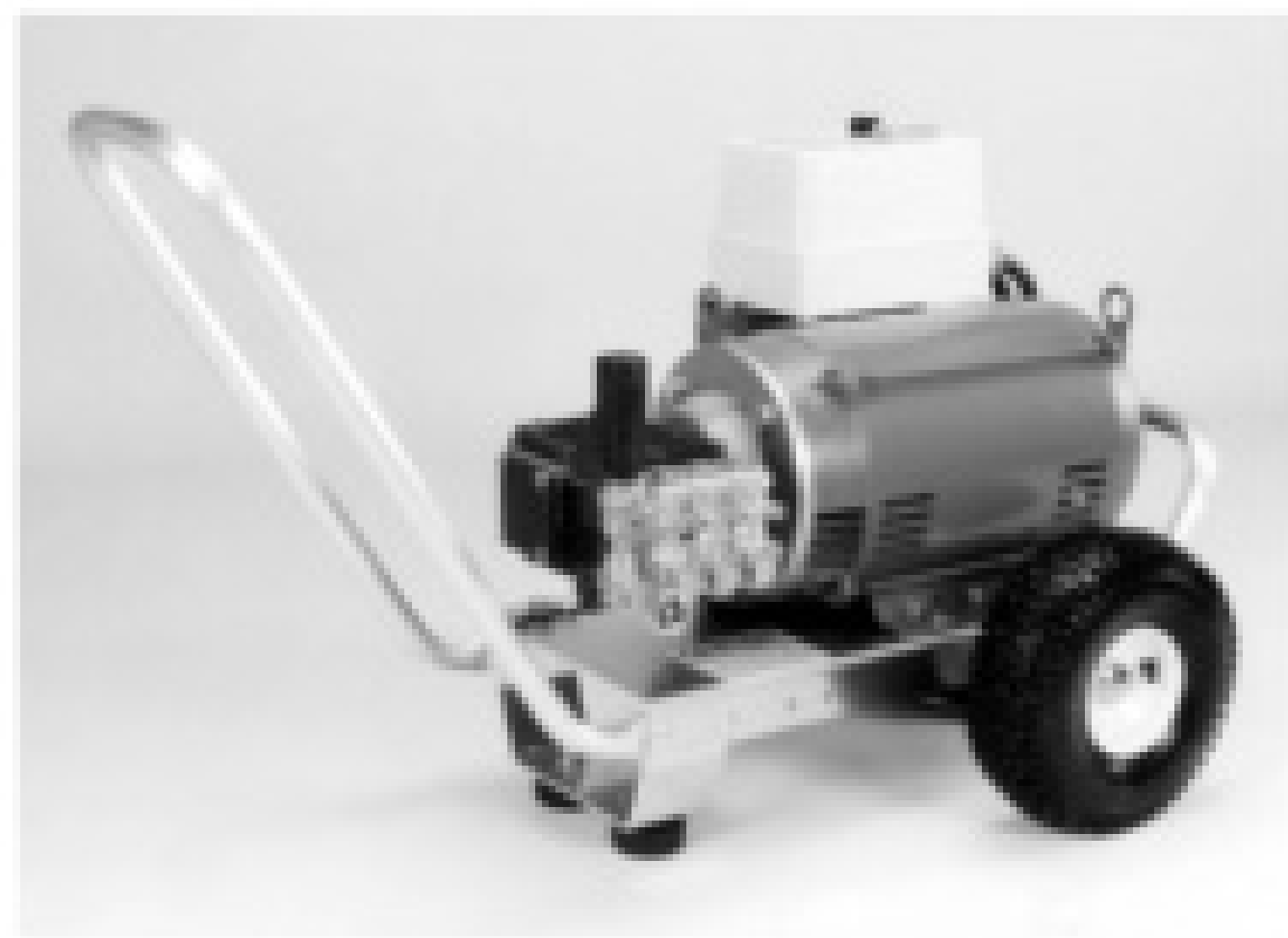

- *Commercial / Industrial Motors
- *12' Cord (no Plug)
- *Includes Stop/Start Button
- *Cool Deck Frame
- *Quiet - Efficient
- *Safe - Simple to Use

Part # 11E30
XMA Series
3GPM @ 3200PSI
6HP - 26 Amp
\$1,419

Part # 11E35
SXMA Series
3GPM @ 3600PSI
7.5HP - 35 Amp
\$1,629

Part # 11E40
RKA Series
3.5GPM @ 4000PSI
10HP - 44 Amp
\$1,889



Electric Powered - Wall Mount - 115 & 230 Volt - Single Phase

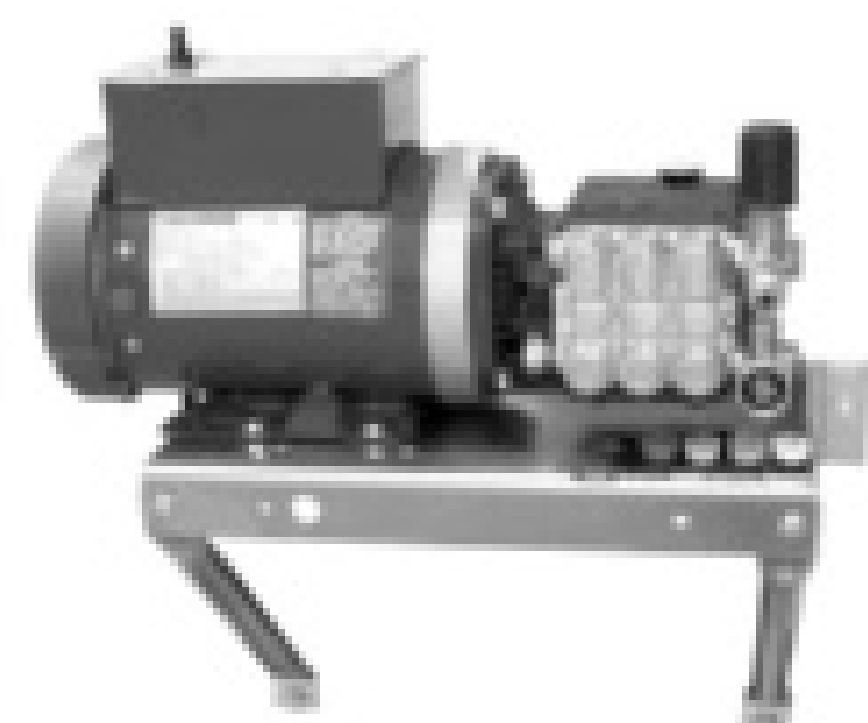

- *Designed For Food Industry
- *Compact & Powerful
- *Cool Deck Frame
- *Jetter Capable
- *Attachment Kits Below
- *Hot Water Pump Kit, Add \$199

Part # 11E68
TT Series
2GPM @ 1500PSI
2HP - 115VT - 18 Amp
\$669

Part # 11E70
TT Series
3GPM @ 1000PSI
2HP - 115VT - 18 Amp
\$689

Part # 11E72
TT Series
3GPM @ 1500PSI
3HP - 230VT - 12 Amp
\$769

Part # 11E74
EZ Series
4GPM @ 2000PSI
6HP - 230VT - 26 Amp
\$1,419

Auto Stop / Start Feature
230Vt Add \$259

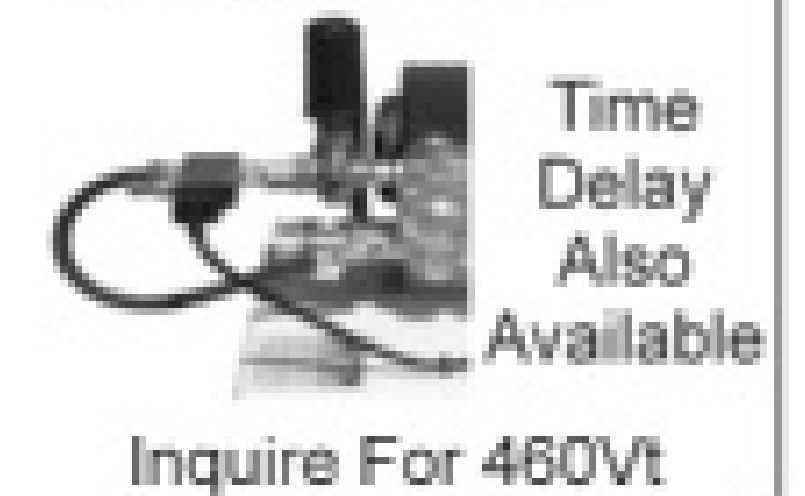

50' Super Kit

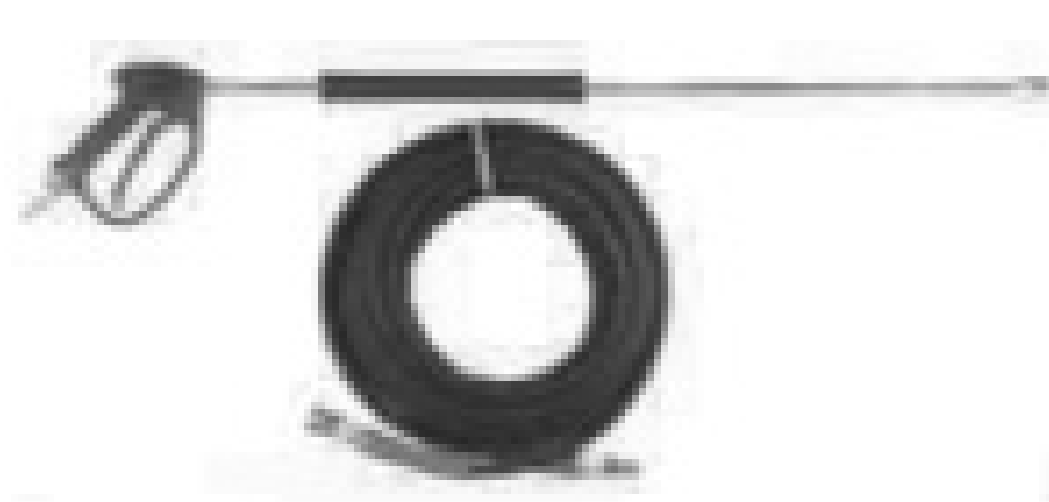

Part # 11564 \$64
Up to 4000PSI
Part # 11584 \$84
Up to 5000PSI

100' Deluxe Kit

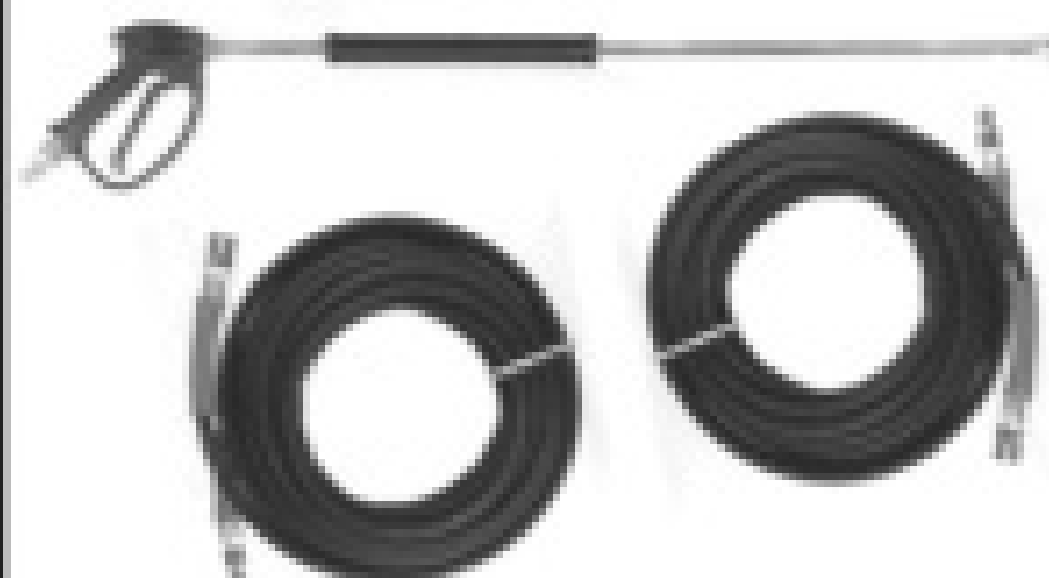

Part # 11109 \$109
Up to 4000PSI
Part # 11114 \$149
Up to 5000PSI

Pump Kits



Skid Mount Versions

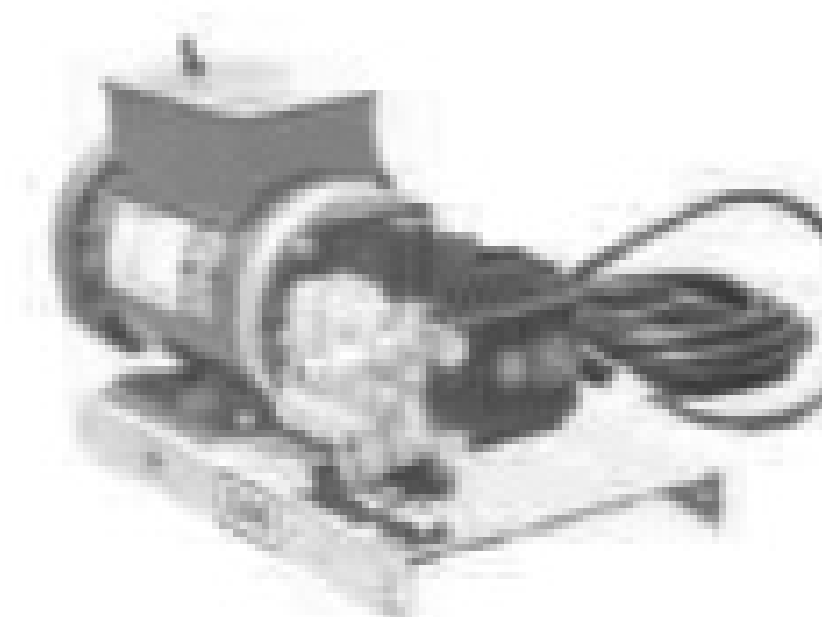

Most Models Are Available
With Skid Mount
Part # 19964 \$19.99
Includes Legs & Feet

Hot Water Pump Kit



3500PSI Part # 19920 \$199
4500PSI Part # 19936 \$289
Fits Most Models, Allows Use of
Incoming Water Up To 185 F. Deg

January

Enviro Waste Oil Recovery Mahopac, N.Y.



Colin Deems combined old-school looks and modern options and creature comforts in this 2004 Kenworth W900. The Mack green and white rig, built out by Presvac Systems, is powered by a Caterpillar C-15 550-hp engine with a 13-speed Eaton-Fuller transmission, and features a 4,200-gallon tank and Fruitland pump.

February

Goodwin Septic Cleaning Wisconsin Rapids, Wis.



John and Jody Banta's white and red 2007 International 7500 was built out by T-Line Equipment and outfitted with a 3,600-gallon steel tank with epoxy lining and an NVE 506 liquid-cooled pump. The service vehicle is powered by an HT570 310-hp International engine and Allison 3000 Rugged Duty Series automatic transmission.

March

Steve 'O' Septic Monticello, Minn.



Steve Langanki bought this 2000 Sterling LT 9501 in 2007, shortening the frame by 54 inches, and had Engle Fabrication Inc. convert it for pumping. The truck has a 3,300-gallon steel tank with HXL400WV Masport pump. Power is provided by a 310-hp C-10 Caterpillar engine with 10-speed Eaton-Fuller transmission.

Cast Your Ballot Online!

2008 CLASSY TRUCK of the Year!

Welcome to the dream garage for pumping professionals. C'mon in and check out some of the best-looking vacuum trucks rolling the roads of America.

The parade of service trucks that graced the pages of *Pumper* over the past 12 months offers an impressive combination of head-turning paint jobs and creative graphics, rock-solid drivetrains, well-appointed interiors and the best convenience features the industry offers.

Just by driving these impressive rigs, our *Classy Truck* contractors are helping elevate the professional image of the entire industry. Looking good on the road and maintaining trucks that function properly every day shows a concern for customers and doing the job right.

We'd like to give an extra salute to all of the contractors who submitted photos and stories about their new trucks over the past year. We know you take a personal pride in your service vehicles and we appreciate you sharing them in the pages of *Pumper*.

In our third annual *Classy Truck of the Year* competition, we gather each of our monthly *Classy Truck* offerings for a head-to-head comparison.

Each of these trucks is a credit to the industry and a winner in our minds. But it's time for you to cast your ballot for the best-looking truck in the garage. The *Classy Truck of the Year* will be chosen through your vote and a panel of *Pumper* judges. The winning truck will drive back into the magazine and park on the cover of the February *Pumper & Cleaner Environmental Expo International* show issue.

To vote for your favorite truck, log onto www.pumper.com today.



The winning truck will be featured on the cover of the show issue of *Pumper*!

GET IT IN GEAR!

Step 1: Look over the 12 Classy Trucks for 2008

Step 2: Pick your favorite entry

Step 3: Go online at www.pumper.com and log your vote. (one vote per IP address allowed)

ACT NOW: The deadline for voting is Dec. 29.

MAKE YOUR NEW RIG A CLASSY TRUCK!

Seeing your truck in the pages of *Pumper* is easy:

Step 1: Clean and detail your truck

Step 2: Snap a variety of clear photos with your digital camera

Step 3: Send the photos, along with a detailed description of the truck and accessories, to editor@pumper.com

April

Martin Septic Service Winchester, Va.



Terry and Susan Carlyle proudly drive this white 2001 Mack Vision built out in 2007 by House of Imports. The rig is powered by a Mack 430 engine with 13-speed Eaton-Fuller transmission. It carries a 3,600-gallon steel tank and Jurop pump, and also features a 3,000-psi jetter with an automatic hose reel and 200 feet of hose.

July

Polar Pumper Septic Service Palmer, Alaska



Gary Wilson runs this blue 1985 Peterbilt 359 vacuum truck rebuilt by Engle Fabrication Inc. It has a new 3,600-gallon stainless steel tank paired with a Jurop DL 140 pump, powered by a 300-hp Cummins engine and 13-speed Eaton-Fuller transmission. It also has 18,000-pound front and 38,000-pound rear air-ride suspension.

May

Dillard's Septic Service Annapolis, Md.



James Dillard had his beat-up, 20-year-old Chevrolet C70 from Lely Manufacturing beautifully restored after a rollover crash. James' first service truck still uses its Chevy 366 gas engine and 5-speed transmission, frame and Masport pump, and 2,300-gallon steel tank, all repaired by A & D Truck Services, Woody's Truck Repair, and A.H. Miller Welding.

August

A & B Septic Tank Cleaning Ashland, Ohio



Todd Young had this red, white and blue 2001 Freightliner Classic XL built by House of Imports. The heavy hauler is powered by a 470-hp Detroit Diesel engine married to a 10-speed AutoShift transmission. It's equipped with a 4,000-gallon steel tank and a 367-cfm NVE pump. Stainless steel panels make it shine at jobsites.

June

Aardvark Waste Services Hurricane, Utah



Steve Biggs made a daycab semi out of this 2003 Peterbilt 385 to load up car wash pit or residential septic system waste all day long. The 4,000-gallon steel tank from FRB Welding is pushed by a 500-hp Cat C-15 engine and 10-speed Eaton-Fuller transmission. It has a Robuschi RB-DV65 blower pulling 900 cfm and 36-inch manway.

September

J & E Sanitation Rough Creek, Pa.



Eddy King and Josh McNay had Pik Rite Inc. build this 2007 Peterbilt 357 vacuum truck with 4,000-gallon steel tank and Masport 400 water-cooled pump. It's powered by a 440-hp Caterpillar C-13 engine and an Eaton-Fuller 8 LL transmission. The company prefers the all-white paint scheme for its fleet.

October

Advantage Septic & Drain Upsala, Minn.



Steve Lojovich likes to pump three septic tanks at a time with this large-load 1998 Freightliner FLD 112 with 4,000-gallon steel tank from Engle Fabrication, Inc.. It's powered by a 370-hp Cummins M-11 engine and 10-speed Eaton-Fuller transmission with differential lock. Peterson Blacksmith also worked on the refurbished rig.

November

G.A. Downing Co. Inc. Septic Service & Pumping Minot, Maine



Buster Downing's septic service rig is a refurbished 1999 Peterbilt 330 powered by a Caterpillar 3126B 300-hp engine and 10-speed Eaton-Fuller transmission. The truck features a Progress 2,800-gallon aluminum tank, Masport HXL15 pump and 1,200-psi pressure washer.

December

T.A. Lauritsen Septic & Drain Inc. Montevideo, Minn.



T.A. Lauritsen drives this 2007 Kenworth T-800 rig built by Engle Fabrication Inc. The truck is powered by a 370-hp Cummins engine with 10-speed Eaton-Fuller transmission. It carries a 3,500-gallon stainless steel tank and 1,000 cfm Robuschi 65 air-cooled blower. The truck also has a 55-degree hoist.

CCLS NOT SOLD BY SALESMEN

Very little **CCLS** is sold by actual salesmen. So you wonder how could **CCLS** be the largest selling bacteria product in the trades? It's because **CCLS** is not sold by salesmen: it is **presented by experts**. And those **experts** are the technicians on pump trucks.

People are more likely to buy **CCLS** if they understand the benefits of the product. And the best way to be sure they understand the benefits is to help them to understand their septic systems:

1. The components of the system
2. The proper operation of those components
3. Why septic systems fail
4. How to keep them from failing (maintenance: regular pumping & **CCLS**)

This is best accomplished in 2 ways:

1. Make sure your service personnel are **experts** in septic system operation, and
2. Provide your customers with written educational materials, to make them experts too.

Cape Cod Biochemical Company, manufacturers of the **CCLS** family of septic system treatment products, provides everything you need to educate your service personnel **and** your customers. We have been committed to customer education since 1976, and we publish many informative brochures, including the industry-standard pamphlet, "**What Everyone Should Know About Septic Tank Systems.**"

To find out more about our program of "Better Business Through Customer Education", as well as our state-of-the-art biological products formulated for what you do on the job every day, please call 1-800-759-2257 to request our product information package. Or log on to www.SepticOnline.com. There is no cost or obligation, and no obnoxious salesman will call you (a big plus with us). We're not salespeople... we're **experts**. And that comes from over 30 years of hands-on experience.

Remember, your best customers are informed customers. Let us help you inform them. Please call today. Thank you.

—Rick Howe, President



Visit us in Louisville
Booth #3201

GREEN PRODUCTS FOR SEPTIC PROFESSIONALS SINCE 1976

CAPE COD BIOCHEMICAL COMPANY

P.O. Box 990 • Pocasset, MA 02559

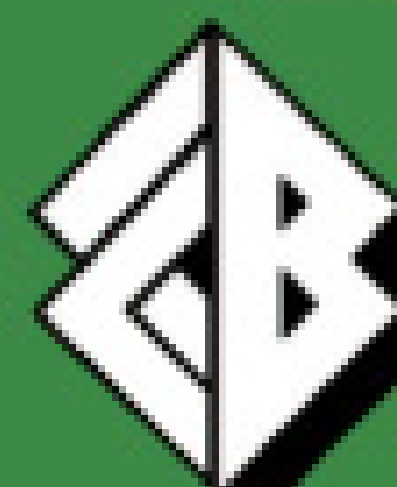

1-800-759-CCLS
(1-800-759-2257)

FAX: 508-564-9974 • www.SepticOnline.com

VISA

MasterCard

ccls®

BIO-REM-E-D

DrainMaster®
CONCENTRATED DRAIN CLEANER

Septic Tank Riser, Lid & Safety Pan™

**FREE FREIGHT ON
FULL CARTONS!**

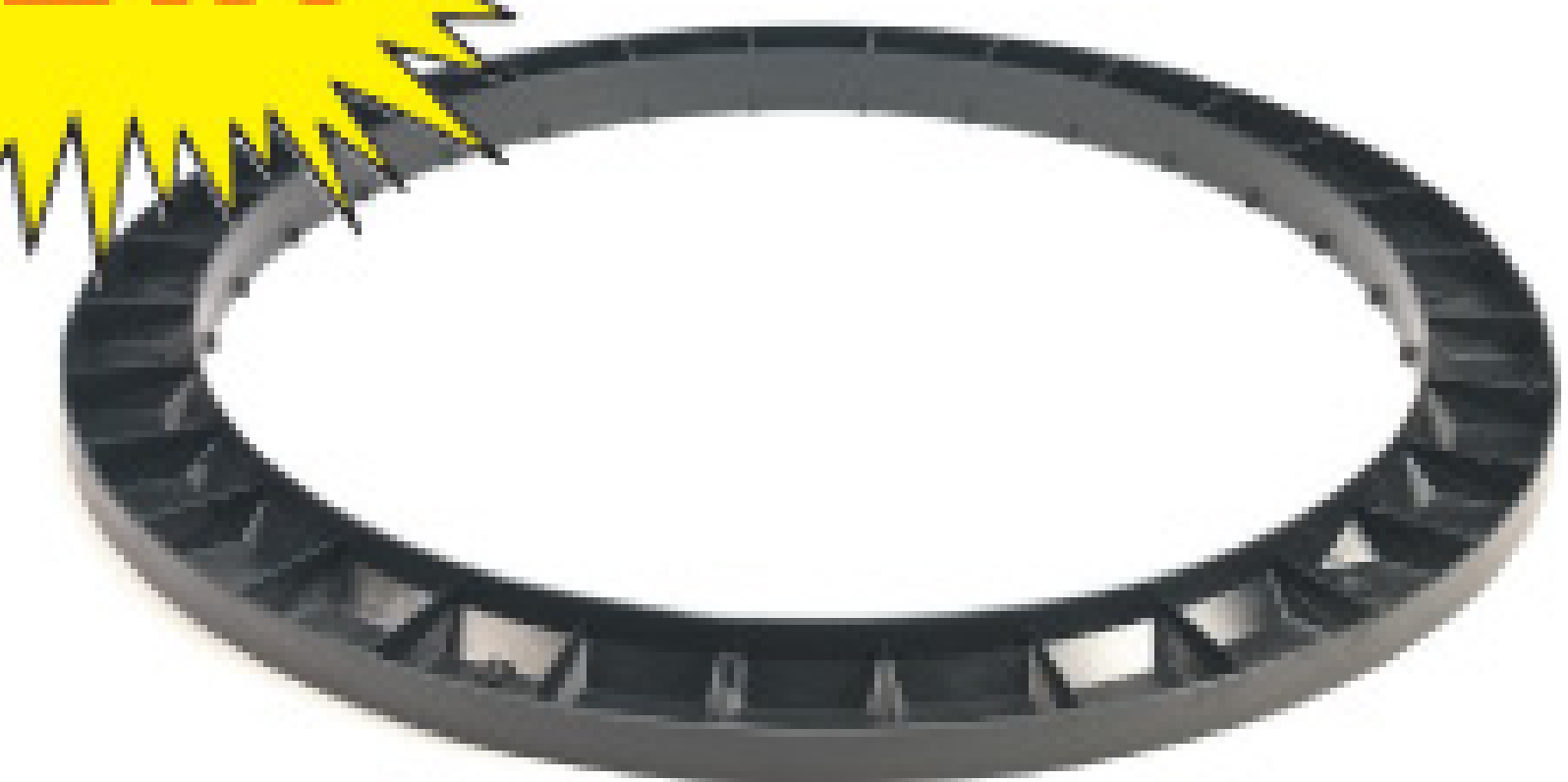
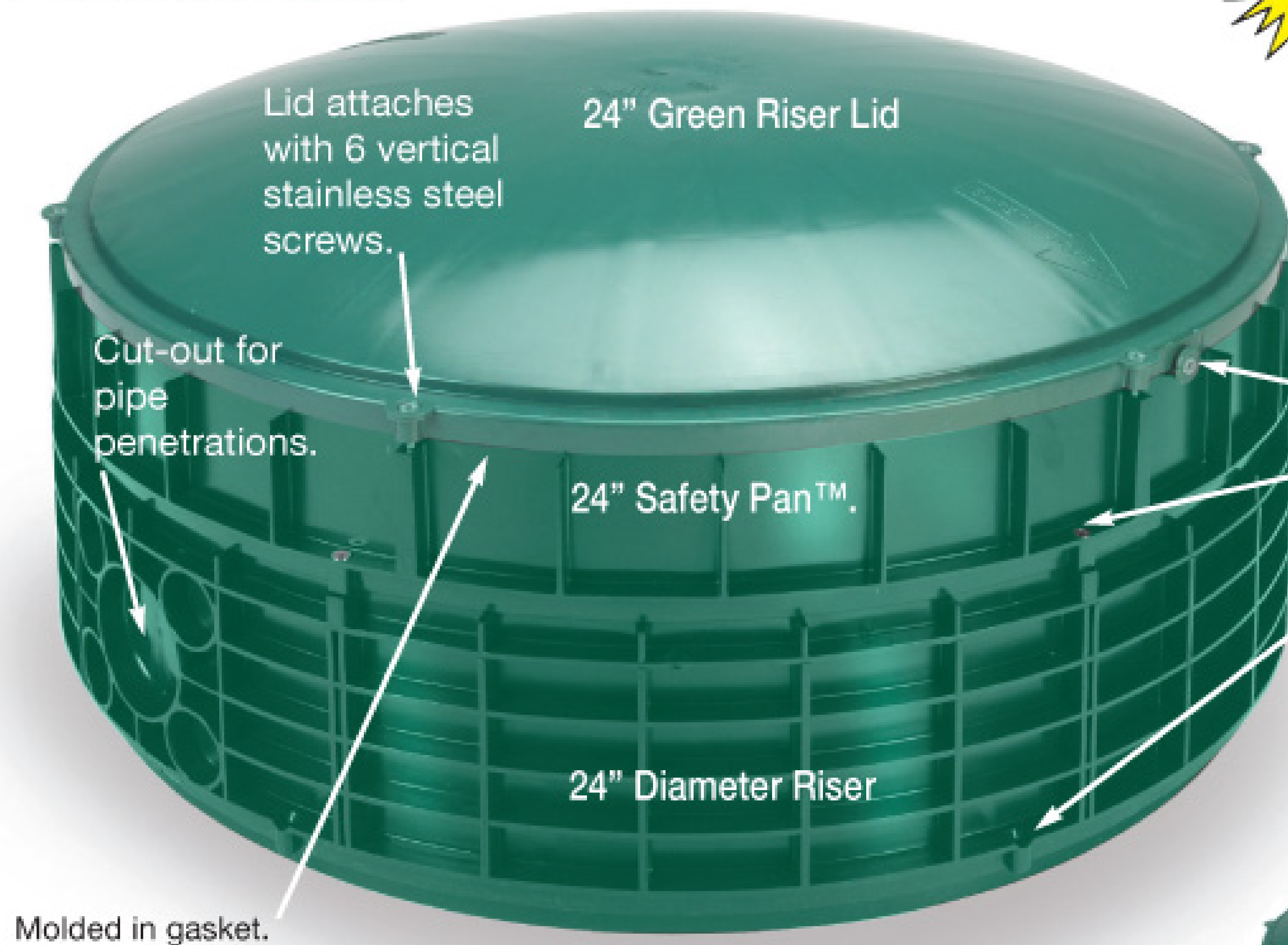

Tank Adapter Ring

New - Horizontal Safety Screw.

Safety Pan™ to Riser attachment with 6 vertical stainless steel screws.

Riser to Riser attachment with 6 vertical stainless steel screws.

Patent Numbers
5,617,679 &
5,852,901; other
pats. pending.

Riser Lid

with Molded-in gasket.
Available in 12", 16", 20" and 24" diameters.

Concrete Lid w/handle

Safety Pan™

Safety Pan™ available in 16", 20" and 24" diameters.

Riser

For septic tanks. Stackable in 6" increments. Available in 12", 16", 20" and 24" diameters.

Tank Adapter Ring

For mounting riser flush to top of tank when casting-in is not an option.



Available in 12", 16", 20" and 24" diameters.

Effluent Filters

Patent Numbers
6,319,403; D 431,629; other
pats. pending.

800 GPD
ANSI/NSF
Standard 46

4" Sch. 40 &
SDR-35

EF-4
4" Filter

1500 GPD
ANSI/NSF
Standard 46

4" Sch. 40 &
SDR-35

**244 ft. of
1/16" filtration
area.**

EF-6
6" Filter

Gas/Solids
Deflector

One-Piece Tank Seal

For concrete Septic tanks and D-boxes.
Accepts pipes from 1-1/2" to 4".
Mounts with or without concrete flash.



TS-4-RUBBER TANK SEAL
(will hold 10psi)
TS-4PRO TANK SEAL
(will hold 5" vacuum)

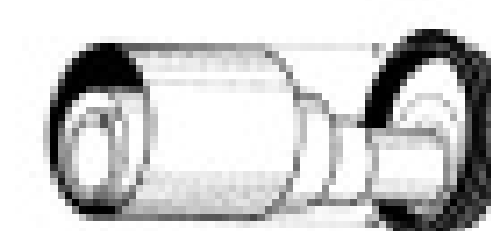

Free Freight: 32c

Patent No's
4,951,914,
5,624,123
& 5,711,536;





Cold and Hot Water Pressure Washers

Simpson and Delco have been making top-quality pressure washer for decades. Available on trailers, skid mounts, or as portable models, our pressure washers give you the durability you want to keep cleaning on site, and the power you demand to clean your equipment back in the shop!

Call Bob Pligge at (847) 348-1573,
 email bpligge@simpsoncleaning.com
 or check out our websites
www.simpsoncleaning.com
www.delco-cleaning.com



Wastewater Treatment Systems

Cromaglass

Since 1965, Cromaglass has provided top-rated wastewater treatment systems. Find out for yourself. Call Cromaglass today.

(570) 326-3396

Fax: (570) 326-6426

nature undisturbed

Cromaglass Corporation • P.O. Box 3215
 2902 N. Reach Rd., Williamsport, PA 17701



Wolf Creek Co.

Original Bauer

Portable Piping

Bauer Fittings

Polybarb™ Pipe & Tails

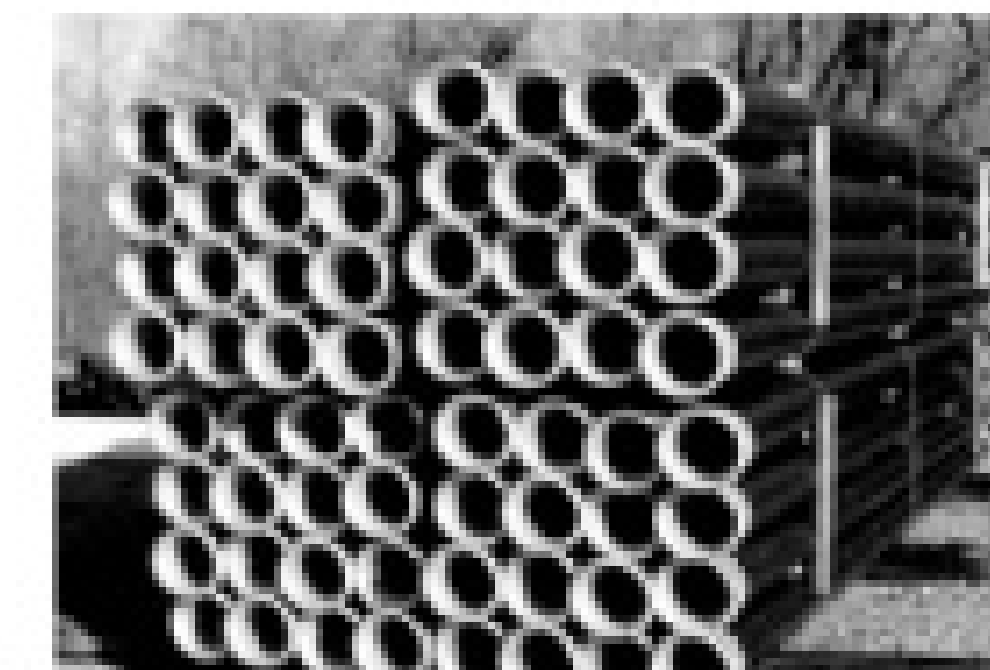

Polybarb™ HDPE pipes and fusible tails available in 4" to 12" diameters up to 40' in length.



Industrial Vac Tubes

Available in weldable, hose insert, and flanged connections. Fittings available from 2" to 12".

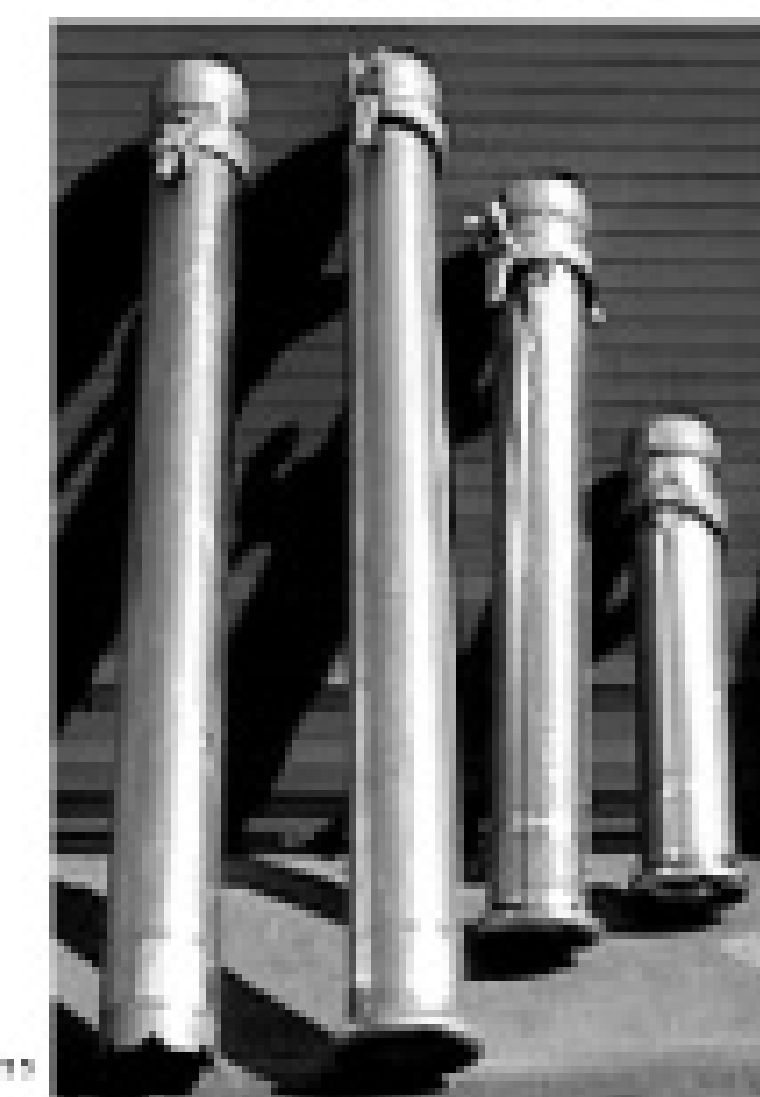

We can fabricate aluminum vacuum evacuation or suction tubes per your specifications. Using the Bauer Coupler or Anfor Coupler.

Bauer Pipe





Galvanized piping available in 2" to 12"



800.488.7305 • www.wolfcreekcompany.com



The angel said to them, "Do not be afraid. I bring you good news of great joy that will be for all the people. Today in the town of David a Savior has been born to you; he is Christ the Lord." — Luke 2:10-11



Christmas greetings to our many valued customers.

We wish you peace and joy for the holidays.

From Erick, Jennifer and the crew at



**ERICKSON
Tank & Pump**



Supersucker®

The Best Industrial Vacuum Unit on the Market Today!

- ◆ Heavy duty construction to tackle jobs in the most extreme conditions
- ◆ Designed for easy operation, easy cleaning and easy maintenance
- ◆ Unloads efficiently to save both time and money
- ◆ High dump option allows rear lift height to 60"

Contact Super Products today for more information on our line of Supersuckers or to schedule a free demonstration!

800.837.9711 • www.superproductscorp.com



DML2000

The best Magnetic Locator on the market

- Easily pinpoint buried septic tanks, water valves, water meters, survey pins, iron pipes ...
- All weather operation; -20° to 120° F
- Works great in rain, sleet or snow.
- Waterproof Sensors; base of electronics to the crutch tip.
- Comes with a Hard Plastic carrying case or a soft-padded case.
- USA Bluebook P/N: 64978
- Best warranty in the business, a **LIFETIME WARRANTY**

Dunham & Morrow Inc.
43676 Trade Center Pl., Suite 145
Dulles, VA 20166 703-661-2144
www.magneticlocator.com

Steel Tanks



- Polished Aluminum Skirting and Tool Boxes
- 2008 GMC 5500 Duramax, Diesel, Allison Automatic Transmission, 19,500 GVW, 1000 Waste, 350 Fresh \$59,000
- 2008 Ford, 6.4 Diesel, Automatic, 19,000 GVW, 950 Waste, 300 Fresh..... \$57,000
- 2008 Dodge 5500, Cummins Diesel, Allison Automatic, 1000 Waste, 300 Fresh, 19,500 GVW \$60,500
- 2007 Chevrolet 7500, Diesel, Allison Automatic, Air Brakes, 1400 Waste, 400 Fresh..... \$70,000
- 4 Wheel Drive Units Available

Aluminum Tanks



- by Amthor 5/16" Thick
- 2008 GMC 5500 Duramax, Diesel, Allison Automatic, 19,500 GVW, 1000 Waste, 400 Fresh \$67,500
- 2008 Ford, 6.4 Diesel, Automatic, 19,000 GVW, 1000 Waste, 400 Fresh \$65,500
- 2008 Dodge 5500, Cummins Diesel, Allison Automatic, 19,500 GVW, 1000 Waste, 400 Fresh..... \$68,000
- Any Brand Truck Available
- Used Septic and Toilet Trucks Available



8 RESTROOM | 10 RESTROOM | 12 RESTROOM | 14 RESTROOM | 16 RESTROOM | 20 RESTROOM

SLIDE-IN UNITS & USED TRUCKS AVAILABLE / MASPORT, JUROP & CONDE VACUUM PUMPS
CHECK OUR PRICES
LANE'S VACUUM TANK, INC.
3133 VANZORA RD. • BENTON, KY 42025
800.592.3308 • 270.527.9945
RODNEY LANE'S CELL 270.832.3793



Refuse Systems

Your truck specialists in the solid and liquid waste industries.



2008 Peterbilt 365 with 5000 Gallon Tank

CAT C13 430HP 1650 Ft/Lbs Torque, Full Compression Brake (Three Stage), Allison 4500 RDS-P with 5YR/Unlimited Mile Warranty, 20,000# Front Axle; 46,000# Rear Axle, Peterbilt Air Trac Suspension, Full Locking Differential, Aluminum Wheels on Outside, Hendrickson Composites 13.2K Steerable Pusher Axle, Air Ride Driver Seat, Adjustable Steering Column, Power Windows, Locks, Cab Air Suspension, Pik Rite 5000 Gallon Carbon Steel Tank, See Level – Digital Tank Level Indicator, Moro PM100 Pump, Aluminum Hose Trays, 4" Intake, 6" Discharge.



Peterbilt 340 Industrial Vacuum Trucks

Automatics and Standards in stock ready for delivery. DOT 407/412 3150 Gallon Cusco units. Moro PM100 Pump, Hydraulic full opening rear, Vibrator Box, Air actuated valves, Full Walkway with handrail, 20 Ton Dump Capacity Cylinder.



Peterbilt 340 Standard Vacuum Trucks

Automatics and Standards in Stock ready to go to work. Non Code 3600 Gallon Pik-Rite Tank. Masport HXL400WV Liquid Cooled Pump, Aluminum Hose Trays, Internal Primary to secondary Piping for clean mount. 10 yr Tank Warranty Standard. Options can be added before delivery. Compare our standard Specs to anybody!



2008 Peterbilt Roll Off

Cat or Cummins, automatic or standard transmission, 20fr/ 46 rears, Air Trac or Hendrickson suspension, 60k or 75k hoists, Pioneer or O'Brian tarpers, mounted or cab and chassis still available.



2007 Pre-Emission and 2008 Peterbilt Cab and Chassis

Whether you're putting an old tank on a new truck, or custom building a truck the way you've always wanted, call us and choose from a wide variety of models and specs on the ground. Fast shipping available to your destination. Tank dealers and manufacturers welcome.

877-661-4511

Refuse Sales Team: Gregg Wilkinson | Jason Guzauskas | Jesse Fullilove | Ryan Johle | refusesales@rush-enterprises.com

8810 IH-10 East | San Antonio, TX 78219



www.rushrefusesystems.com



McNeilus
Strong. Smart. Strong Tough.

WASTEQUIP
Actually there for personal service



TOOL RULES

Paul Holstein is the co-founder and COO of CableOrganizer.com. He may be reached through the company's Web site at www.CableOrganizer.com



Ergonomics should play a role in choosing the right hand tool for the work you'll perform with it

By Paul Holstein

ergonomic hand tool for your body type ... and the job at hand:

- Because finger size and placement differs for every user, avoid using tools whose handles have built-in finger grooves. When fingers don't naturally align with grooves, excessive pressure from the raised groove edges can cause discomfort and injury.

- Choose tools with handles that are covered in a soft material, like foam or flexible plastic. Cushioned handles are not only comfortable for long hours of use, but

CUSHIONED HANDLES ARE NOT ONLY COMFORTABLE FOR LONG HOURS OF USE, BUT THEY PROVIDE A MUCH FIRMER GRIP AND CUT DOWN ON SLIPPAGE. HARD-HANDLED TOOLS CAN BE QUICKLY AND INEXPENSIVELY CONVERTED BY ADDING A SOFT SLEEVE.

they provide a much firmer grip and cut down on slippage. Hard-handled tools can be quickly and inexpensively converted by adding a soft sleeve.

- Ensure tool handles are free from sharp edges and seams that might irritate or cut the hands.

- When selecting double-handed gripping and cutting tools, opt for ones with spring-loaded handles that will automatically return to the open position.

- If you need to forcefully pinch or grip an object for an extended time, prevent muscle strain by switching from standard pliers to a clamp or grip.

- Only use tools that allow you to work with your wrist in a straight position.

- For tasks that require force, such as torquing screws and nuts, hammering and heavy chiseling, choose single-handle tools with handle diameters from 1 1/4 to 2 inches. Larger handles allow fingers to wrap comfortably around the tool in a power grip, which prevents slippage and reduces stress and impact on hands, fingers and wrists.

- Just as grip diameter affects work with single-handle tools, the grip span of pliers, snips, cable cutters and other double-handled tools can either make your job easier or cause hand fatigue. For maximum comfort and efficiency for tasks requiring more force (like gripping with large pliers, cutting wires, or snipping through sheet metal), choose tools with a maximum "open" grip span of 3 1/2 inches, and a "closed" grip span no less than 2 inches across.

- Detailed jobs that involve grasping small parts and components with pincers, tweezers or tongs are best done with double-handle tools whose grip spans from no less than 1 inch (closed) to no more than 3 inches (open).

- When a work space is tight but the task at hand requires a good deal of force, opt for "power grip" tools (with handle diameters from 1 1/4 to 2 inches), which are grasped with the entire hand instead of just pinched between the fingertips. This type of grip lets you finish the job in far less time, with far less physical stress.

- Tool length should also be matched to space constraints. Excessively long tools can force you to assume awkward work postures and wrist positions when you're trying to reach components in cramped areas. Instead, choose short-handled tools that give you the freedom to meet the target work area directly, while keeping your wrist straight.

- The palms of your hands are full of pressure-sensitive nerves and blood vessels. To avoid damaging these during high force tasks, it's important to make sure that the handles of your tools are long enough that their ends won't press into your palms. To measure, hold your hand palm-up, with fingers together and thumb against the side of your hand. As long as the tool's handle is longer than the widest part of your hand (the span from the outer edge of your pinkie to the outer edge of your thumb), it's safe to use. ■

Drop into any hardware store or home improvement center and you're likely to find aisles full of tools labeled "ergonomic." But what exactly does that mean for contractor users who pop open the toolbox every day and need reliable tools? Simply put, ergonomics is the science of designing and producing tools, furniture and other work-related implements to improve a worker's efficiency while reducing discomfort, fatigue, and risk of injury.

Ergonomically enhanced tools can include helpful features like angled handles, padded handgrips and non-slip coatings.

You see more and more enhancements like these incorporated in common tools used in the liquid waste industry. However, no matter how impressive a tool's design is, it's almost impossible for it to be universally ergonomic since human physiques and project applications vary greatly from one to the next.

Whether you're shopping for ergonomic hand tools or just trying to select the right one for the job from an existing collection, the key things to consider are whether or not the tool fits your hand, how well it suits the job being done and if it prevents you from straining in ways that could lead to injury. Regardless of how user-friendly a tool is purported to be, the most important deciding factor in what makes a tool ergonomic is, ultimately, you.

To make the decision process easier, here are some guidelines for choosing the right

Beat the new year PRICE INCREASE!
Get yours on order today!



Booths 6025, 5025

Fast Delivery On Custom Builds.

IN STOCK!
Same Day Delivery



HINO

2008 Hino Model 338
 260 HP 6 spd. trans. ,air brakes
2000 Gallon Tank
 Masport HXL4, dual service,
 wash down, Tow package
 Toilet carrier.

\$78,975 F.O.B. Kansas City
 Lease from **\$1579 mo.**

3800 Gallon Septic Tank
 Masport HXL400 water cooled

2008 International 4400
 10 speed transmission

\$105,245
 Plus F.E.T.

Lease from
\$2104 mo.



LaVerne Charlet

L.C.TANKS

email: lctanks@bellsouth.net

fax: 270-898-4055

175 Cascade Dr, Paducah, KY 42003

1-888-848-3727

NEW! 3600 Gallon Septic
 Masport 400 CFM water cooled pump,
 tool boxes, 6" discharge / 4" inlet.

Used Chassis 2002 Freightliner FL112
 CAT C-10, engine brake

\$83,845 Plus F.E.T. (Tank Only)



Refurbished
TWO YEAR WARRANTY

2500 Gallon Septic Tank
 Masport HXL15 - 350 CFM,
 6" discharge, (2) aluminum cabinets.

2008 Ford 750 33,000 GVW,
 260 HP Cummins, 6 speed,
 air brakes.

\$85,977
 Lease from **\$1719 mo.**

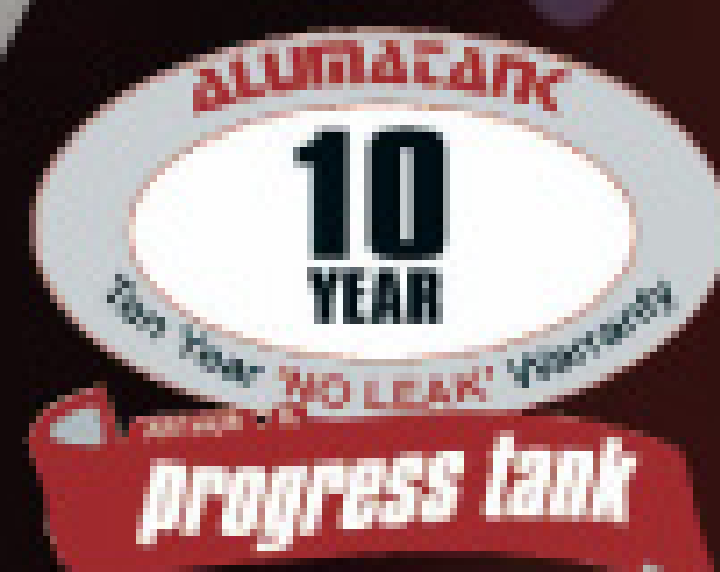

Get More Income with Every Tank Pumped!

With

PRO-PUMP®

The Finest Name in Biological Products for Septic Systems, System Recovery, Odor Elimination and More...

Our Top Selling PRO-PUMP®/SEPTIC SAVER!



SEPTIC SAVER

PRO-PUMP®/SEPTIC SAVER is a combo pack of our two best selling septic treatments: PRO-PUMP®/HC & SP packets, bundle packed as a monthly (12) treatment program.

- Septic System Treatment
- Absorption System Recovery
- Aerobic System Treatment
- Drain & Grease Traps
- Solids Reduction
- Odor Control
- Bio-remediation

VISIT US AT PUMPER EXPO BOOTH #4094!

AUTHORIZED PRO-PUMP PRO DEALER

FREE TRUCK DECALS! Show your customers you sell the very best for their septic systems!

Call Greg Toll Free at 1-800-326-7867 and Become a PRO-PUMP® Pro Pumper Today!

Professional Sales Materials & Technical Support at No Charge!

We provide technical support, combined with informative sales and marketing materials, and we don't sell direct to the consumer! All web-based inquiries are sent to you!

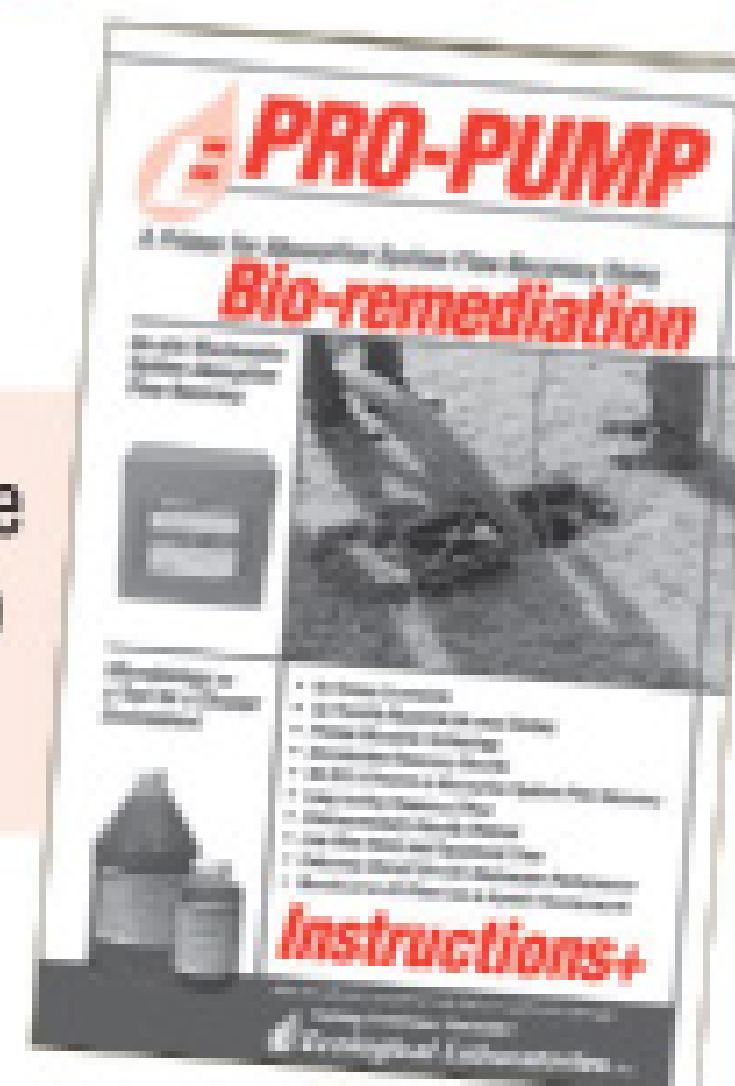

Solving Problems, Naturally!

Ecological Laboratories INC.

CORPORATE OFFICES: 13 Hendrickson Ave., Lynbrook, NY 11563

TOLL FREE: 1-800-326-7867 • FAX: 516-823-3440 • EMAIL: info@propump.com

Visit our web site at: www.propump.com

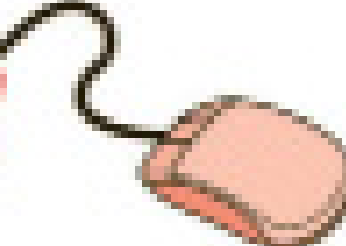

Comforts of Home
Services, Inc.

LUXURY TRAILER SALES



Units come with A/C, Heat, HD Steps and a Large 300 Gallon Waste Tank

- Lowest Interior Floor Height in the Industry
- ADA wheelchair accessible units.
- Unlimited Floor Plans from 8' to 53' Trailers
- Rigid Steel Shell Construction from top to bottom to resist rot and warping.
- Specializing in Customizing trailers to fit your needs.
- Easy Fold-Up Steps & Door Handles
- 24/7 Tech Support for the best customer service available.
- Free Nation Wide Lead Program for our customers.
- Large Capacity Waste Tanks
- High Privacy Partitions are Standard for Added Comfort
- Rigid Platform, our smallest wide body trailers start out with Dual 10" ASTM I-Beams.

See our website for more layouts and options.



INFO@COHSI.COM • 877.382.2935 • WWW.COHSI.COM



4000 Gallon pumper on a 2007 M2 Freightliner
Tank: Bright finish aluminum-5/16" #5454 shell and heads 76" Dia.

Pumping system: Jurop LC420 water cooled pump
Chassis: Freightliner M2-54,000 GVW, C-7 Caterpillar 300 H.P., 10 speed transmission-14,600 front axle-40,000 air ride rear axle.

2800 Gallon pumper on a 2007 International

Tank: Bright finish aluminum-5/16" #5454 shell and heads

Pumping system: Masport HXL 15 (350 CFM)

Chassis: International 4300-33,000 GVW, 245 HP DT466-RDS 3500-12,000 front axle, 21,000 rear axle.



WHITE RIVER DISTRIBUTORS, INC.
BATESVILLE, ARKANSAS

(800)-548-7219
(870)-793-2374
www.lpgbobbails.com



Vacuum Sales, Inc.

51 Stone Road, Lindenwold, N.J. 08021

800-547-7790 Fax: 856-627-3044

www.VacuumSalesInc.com sales@vacuumsalesinc.com

Stock # 13337A, B, C & D



End of Year Blowout

\$123,000.00
Plus F.E.T.

4 available!!!

New 3,600 U.S. gallon, aluminum, vacuum tank with a Masport HXL400WV, Liquid cooled, vacuum-pressure pump installed on a 2009 Peterbilt 340 cab and chassis.

All Peterbilt 340 cabs & chassis are loaded out with options



Stock # 13335 B & C

End of Year Blowout

\$147,000.00
Plus F.E.T.

2 available!!!

New 3,200 U.S. gallon, carbon steel, D.O.T. certified 407/412 vacuum tank; dump type with full open rear door and a Presvac PVB 750 vacuum-pressure pump installed on a 2009 Peterbilt 340 cab and chassis.

All Peterbilt 340 cabs & chassis are loaded out with options



We've got you covered



Unit #18088 2001 Sterling LT9501, Vactor 2112,
Multi Flow System, 1300 Gal. Water Capacity
CALL FOR DETAILS!



Unit #94594 2007 International 7600, Vactor 2115,
Multi Flow System, Roots 824 Blower
CALL FOR DETAILS!



Unit #01234 2005 International 7600, 2008 Guzzler
Classic, Roots 1021 dvj 27", New Debris Body
READY TO WORK!

Many More Units Available • Call for Details!

**Parts and Service
Financing for Used Equipment and Service
Warranties for Most Equipment
We Sell and Service**

**The Largest Selection of Refurbished
Vacuum Trucks in the World**

**1-800-822-8785
www.fssolutionsgroup.com**

Big Fish

ENVIRONMENTAL



Receiving & Processing
For
**Septage • Biosolids,
Fats, Oil & Grease**
— Turn Key Operations —

Facilities Starting at 20,000 Gallons Per Day

P.O. Box 528 • 12608 Taylor Rd.
Charlevoix, MI 49720

PH: 231.547.4429 • FAX: 231.547.2057
[www:bigfishenvironmental.com](http://www.bigfishenvironmental.com)

**Non-CDL
19,500 GVW to
66,000 GVW
Septic / Grease Trap
Portable Restroom
Vacuum Service**



**Complete
'Work Ready'
IN STOCK
Selection!**

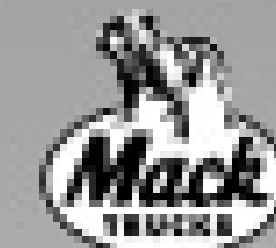
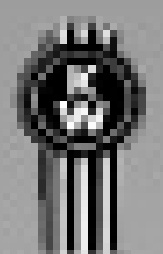
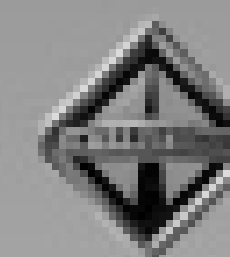

Contact: Mark C. Langworthy **800-261-9009**
e-mail: mlangwor@tanktruckservice.com www.tanktruckservice.com
Tank Truck Service & Sales, Inc.
25150 Dequidre, Warren MI 48091



2009 V.E. Enterprises 'Raptor' Bobtail Tank



Why Choose A V.E. Enterprises Bobtail Tank?

Ten good reasons:

- 1. Built by ASME certified welders***
- 2. All vertical welds are sub-arc welded providing 100% penetration***
- 3. ASTM SA-36 grade 1/4" steel barrel, heads and baffles***
- 4. Barrel padded with 1/4" plate at all contact points***
- 5. 4" channel ring supports on barrel for 90, 100 barrel models***
- 6. Wider hose troughs with standard rear hose hooks***
- 7. Wedge shaped sump or loading lines with 4" butterfly valves***
- 8. Trailers prepped with steel shot blast creating a 2.5 mil anchor profile***
- 9. Primed and painted with DuPont Imron for the ultimate in durability***
- 10. Built for and by our customers; call us for available options***

** Available in sizes from 60 to 100 barrels; turn-key installations available through VE authorized dealers*

Setting the Standard For Liquid Storage and Transport Markets Since 1987.

800-234-2329

www.veenterprises.com
sales@veenterprises.com

10834 St. Highway 53 • P.O. Box 369 • Springer, OK 73458

**
ENTERPRISES, INC.**

FRUITLAND VACUUM PUMPS. SIMPLY THE BEST

We are the #1 vacuum vane pump servicing the oil fields across North America.

The reason is simplicity.

**We don't need gimmicks or water cooling to serve the harshest of applications.
Simple uncomplicated design that works.**

Features:

- Every Pump "Factory Tested"
- Low Maintenance Cost
- Continuous Duty
- Air - Cooled
- No Washboard
- Vacuum to 28 hg.
- Pressure to 30 psi.
- ISO Certified
- 2 Year Factory Warranty
- Automated Lubrication System
- User friendly Maintenance Features
- Models for Tanks sizes from 1000 to 12000 Gallons
- Drive option include; Hydraulic, Direct, Belt, and Right - Angle
- Proven in all environments (sub-zero to 100 degrees plus)



Markets:

- Industrial ●
- Oilfield ●
- Septic ●
- Grease ●
- Environmental ●
- Wastewater ●

**Used and Proven by
World's Top Liquid
Vacuum Service Companies.**

**Vacuum Pump Training
Courses available*

Fruitland Tool & Manufacturing

" Committed to Quality, Reliability, and Guaranteed Performance "

Contact us today: **1-800-663-9003**

Visit us @ www.fruitland-mfg.com For more info.

MOBILE RESTROOM TRAILERS From The Experienced Professionals at WELLS CARGO COG



The **Comfort Elite Series** is the perfect solution for "on-site" portable restrooms and showers. Totally self-contained and environmentally friendly, the **Comfort Elite Series** is a welcome addition to any special event where demanding expectations are the norm. With the industry's shortest production lead times* and unmatched experience, the professionals at **Wells Cargo COG** will work closely with you to find the perfect solution to your mobile sanitation needs.



ADA Units



Showers



Lead Referrals



Call: 888.574.4222

Click: www.wellscargocog.com



Booths 4211, 4212, 4213, 4217, 4219

**Standard units usually
in stock & ready-to-ship!*



**Never Look Back
Warranty Program**

BEST ENTERPRISES, INC.

Located in Cabot Arkansas
wishes you and yours

A Happy and Safe Holiday Season



Thank you to all of our customers and friends. We appreciate your business. We promise to strive every day to give you better service and a better built product. Have a wonderful and safe holiday. We look forward to talking to you next year.

Gayle Humphries



Best Enterprises, Inc.
Cabot, Arkansas

1-800-288-2378 www.bestenterprises.net
501-988-1905

501-988-2880 Fax

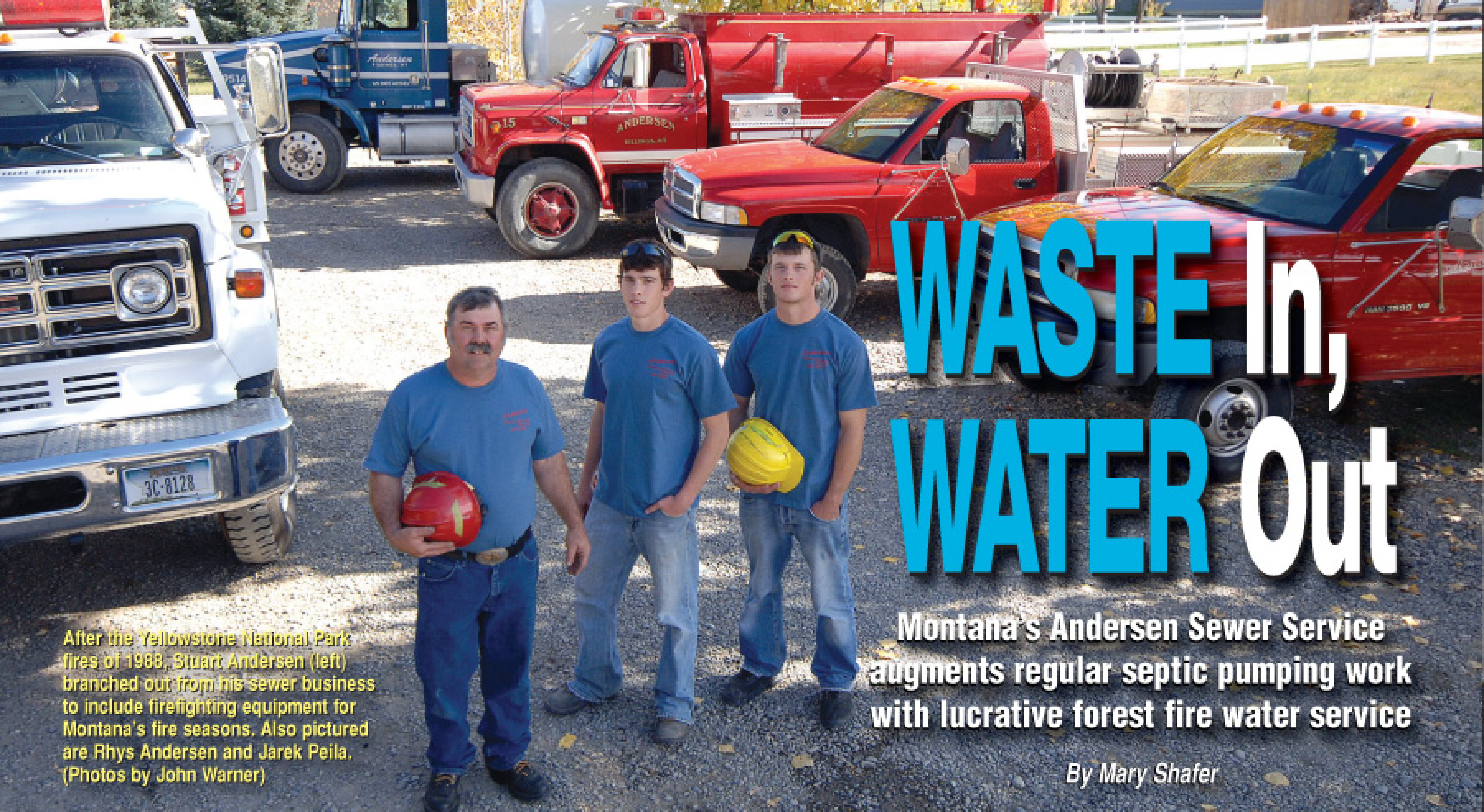

After the Yellowstone National Park fires of 1988, Stuart Andersen (left) branched out from his sewer business to include firefighting equipment for Montana's fire seasons. Also pictured are Rhys Andersen and Jarek Peila. (Photos by John Warner)

WASTE In, WATER Out

Montana's Andersen Sewer Service augments regular septic pumping work with lucrative forest fire water service

By Mary Shafer

The summer of 1988 was the driest in Yellowstone National Park's recorded history. Dry fuels and high winds combined to spread 248 fires in the greater Yellowstone area. On the worst single day, fire gobbled up more than 150,000 acres.

By November, when winter snows finally extinguished the last of the blazes, more than 25,000 firefighters had tackled them, at a total cost around \$120 million.

One of those firefighters was Stuart Andersen, co-owner with wife Kobi Andersen of Andersen Sewer Service in Billings, Mont. Though the destructive fires threatened many lives and properties, they were also responsible for the birth of a whole new business division for Andersen's pumping, jetting and septic installation firm.

This is the unlikely story of one pumper who, through a series of savvy management decisions, application of diverse skills, and a bit of luck, turned a natural disaster into a springboard to catapult his business above a declining local economy.

"MY REGULAR PUMPING CUSTOMERS ARE GENERALLY WILLING TO WAIT FOR ME TO COME IN OFF THE FIRE LINE. THE 15 PERCENT THAT WON'T OR CAN'T WAIT, WE REFER TO A COLLEAGUE. WE DON'T CONSIDER THEM COMPETITION. THEY DON'T STEAL OUR CUSTOMERS."

Stuart Andersen

WINDING ROAD TO SUCCESS

In 1984, the Billings meatpacking plant where Stuart Andersen worked went out of business. He'd been working on the side with a small pumping outfit, and decided to try his hand as an entrepreneur. With a background in metal fabrication and welding, he says, "I built my own pumper truck and went out on my own." His first jobs included line rodding, minor plumbing and excavation. "You had to go out and find the bad sewer lines to get the repair work, so I started rodding." Excavation jobs soon included septic system installation.

The Billings area has lots of clay and sandy or rocky soil, with some areas having high water tables. In other places, water lies 300-400 feet deep. Due to these conditions, there are more municipal sewers than septic systems, even in small towns.

When septic systems are required, Andersen generally puts in standard or shallow mound systems with drainfields, perforated pipe and gravel. He also installs pressure-dosing systems when needed, but stays away from any advanced treatment systems. "Those take too much time and messing around," he explains. "I refer those jobs to other contractors."

By 1988, Billings had annexed the west end of the city onto its sewer system, and septic work decreased. The region's economy was also in a slump, further limiting work poten-

Profile

Andersen Sewer Service Billings, Mont.

Owners: Stuart and Kobi Andersen

Years in business: 24

Employees: 3

Specialties: Septic pumping, installation, inspection and maintenance of sewer and water lines, grease traps, drainfields and drains; forest fire service

Service area: Metro Billings

Associations: Northern Rockies Wildfire Contractors Association





Stuart Andersen (right) and employee Sam Bower clean grease from a restaurant in Billings, Mont.

tial. Andersen saw the writing on the wall and diversified into municipal sewer installation. "I did quite a few of those for 3-4 years, which made up for the septic work we lost. But then that was done and building picked up again, so we went back to septic installation." Throughout that time, Andersen remained strong in the pumping area.

Building is still booming in the Billings metro area, despite the general downward trend in construction nationally. Volume-

wise, about 85 percent of Andersen's business is septic pumping. Some 20-25 percent of this work is commercial — restaurants, nursing homes, chemical plants and offices located along the Cenex oil pipeline that brings crude down from Alberta, Canada, to Billings refineries. The rest is residential work.

Septic and drain-field installation and repair make up about 5 percent of annual volume. The remainder of Andersen's work is on the forest fire fighting line, the company's most recent service addition. Though this work basically only happens two months out of the year, the company bills as much monetarily as it does the rest of the year for all other services. It was an

unplanned but fortuitous new revenue stream.

NEW OPPORTUNITY

In June 1988, major forest fires began in Yellowstone Park. Government representatives called Andersen to haul water in their tankers to supply the fire trucks. During this function, Andersen's tank trucks are referred to as "ten-

ders," since they're tending to the needs of the fire extinguishing pumpers. At first, he was too busy to consider the request. As summer went on, sewer installation slacked and the fire situation intensified.

"When we got less busy, I took one of our trucks over (to local government offices for inspection) and they were offering pretty good money to rent our trucks and crews. I realized if I could provide more tanker/ten-

Andersen proves to be dog's best friend

Ever mindful that customer care is the name of the game no matter what service he performs, Stuart Andersen always tries to go the extra mile for his clients. That philosophy was sorely tested on one particular residential pumping visit to the west end of Billings, Mont.

"It's a part of town where you don't even want to get oil on the driveway," recalls Andersen, "so I put a tarp down beneath my truck. The lady had two matching Samoyeds, beautiful dogs."

As a volunteer Emergency Medical Technician with the local rescue squad, Andersen is hyper-aware of safety issues, and always tries to make sure children and animals are away from his work around open septic tanks. He told his customer to make sure her dogs were inside. She told him not to worry, that they were inside an electric fence.

He lifted the tank lid. "I thought I was being really careful," he says. "I grabbed the first coil of hose off the pump truck, looked up, and there was one of the dogs, looking at me over the open tank." Andersen ran over to the tank. "The other dog was down in it, belly up. He wasn't breathing. I grabbed him by the collar and dragged him out."

As he did so, Andersen saw a lady watching him from a window across the road. He grabbed a garden hose and quickly washed the dog down as best he could, but the creature wasn't moving.

"I cupped my hands over the dog's nose and blew into his nostrils," Andersen says. "I blew several times, but nothing happened, so I flipped him over and started giving him chest compressions."

Just then, the customers' two little kids came running out. "What did you do to our dog?" they asked.

Andersen said, "Go get your mother."

She came outside, saying it was all her fault.

"Meanwhile, I kept working the dog and told her there was a vet a couple miles away. She went in and called the vet."

Andersen kept working on the dog, and when the woman came back out, the pet finally coughed. Within a half-hour, the lucky dog had come back around completely. Not only had Andersen saved a life, but he'd also saved the customer relationship.



The Andersen family, which runs a successful pumping business from their homestead outside Billings, Mont., includes (from left) Stuart and Kobi Andersen, and their son Rhys.



Above, Stuart Andersen displays the mobile hand-wash station he built from scratch. The unit is used by the federal government at fires and other disasters. At right, Andersen pumps grease through a screen at the Billings wastewater treatment plant.

“I’M PICKY ABOUT OUR WORK, AND IT’S QUALITY FIRST AND THE DOLLAR SECOND. I WANT TO BE ABLE TO HOLD MY HEAD HIGH NEXT TIME I SEE MY CUSTOMERS.”

Stuart Andersen



ders, I could make some serious money, so I started building trucks. I love doing metal fabrication, and we even sold some of them.

“A lot of fire areas back up to Forest Service lands that have narrow roads and smaller load limit bridges. They won’t support bigger trucks, so they called in the smaller tenders we build.

“I also wanted to be out where the action was,” Andersen recalls, “so I took fire training. It’s taken quite a few years, but now I’m qualified to be a Strike Team Leader. You’re in charge of five different engines out there on the fire.”

IN THE GROOVE

It only runs July through the first week of September, unless the company gets called to help overburdened firefighters in California or other neighboring states, but fire suppression work has become big business for Andersen. “There were a couple of us that got started real early, but now everybody’s in it,” he says.

Contracts are for equipment and the labor to run it. These used to be annual, but now cover three-year commitments. The government considers equipment age, contractor performance rating based on evaluation of previous engagements, and personnel ratings and capabilities.

“We have to bid all this work, against anyone from all over the United States,” Andersen explains. Would-be fire contractors must commit to availability during fire season, which in dry years can go as late as Christmas.

He’s structured his regular pumping busi-

ness so that the seasonal fire work isn’t much of a disruption. “My regular pumping customers are generally willing to wait for me to come in off the fire line. The 15 percent that won’t or can’t wait, we refer to a colleague. We don’t consider them competition. They don’t steal our customers.”

ORGANIZATION MATTERS

With just three full-time employees, his company runs lean. He keeps everything covered through sheer determination when the season is in full swing. “I’m used to long hours and getting it done, whatever it takes. Most of the time I’m running by myself, though my

HAZARDS OF THE TRADE: Regulations and paperwork

Stuart Andersen says he’s far less intimidated by the danger of seasonal contract work on the fire lines than he is by the reams of paperwork and regulatory compliance efforts required by the government to do it.

All National Park Service fire contractors must be registered on EaTIS (Equipment and Training Inventory System), an online database that allows site managers to keep track of available resources. They must also be entered in what’s called ROSS (Resource Ordering and Status System), which tracks the availability of those resources through a government Web site. Fire contractors are also registered with Central Contractor Registration (CCR), a Department of Defense database, since fire workers sometimes end up doing business with the military.

Another database government contractors must register with is ORCA, the Online Representations and Certifications Application. It’s an e-government initiative designed to replace the paper-based Representations and Certifications (Reps and Certs) process. This information includes contractors’ Dun & Bradstreet numbers and other ownership specifics. Lastly, Andersen is registered with the U.S. Department of Agriculture in Missoula, Mont.

“It’s a paperwork nightmare,” admits Andersen. “The paperwork stays in each truck and when the crews get to the fire, the government representatives take care of daily time logged and all that. We process our own payroll through our accountant.”

Is it all worth it? Andersen says yes, but cautions other pumpers considering getting involved in this kind of contracting.

“Don’t count on making a living off of it. You might have a good year or a bad year. We’ve had good fire years, but that could change tomorrow.

“The general public thinks we’re out there making the big bucks, but we have to have a lot of money to get started. (Department of Transportation) inspections, workers compensation, training and certification, insurance, plus employee wages all take a big chunk. And you have to have enough people on each vehicle, or you can’t contract it.”

boy Rhys has helped over the last couple years. When my daughter Ashli turned 18, she started firefighting with us, too.

"Last year, we ran 20 employees during fire season. This year it was 16, full time. It's temporary work, but people make some good money. They all have to be trained and certified, and there's an engine boss on every truck. We run three people to an engine."

Rigorous training required for all fire workers is part of what limits available help. Each completes a basic Wild Lands course, including standards of survival, shelter deployment and a work capacity test for physical endurance for firefighters. Water tender drivers, who work in dangerous conditions on unpredictably moving fire lines, must be able to walk a 15-minute mile. All workers must carry a red card listing their official qualifications, and are required to rotate out for two days break after 14 days on the fire line.

One thing that frustrates Andersen is sometimes having to turn work away. "In addition to supplying fire suppression water, we also do graywater pumping from hand-wash and shower stations, when we have time. I should be doing that all the time, but I can't find enough help."

THE RIGHT STUFF

Andersen's fleet also includes three pumpers: a 1982 Ford F800 with a 2,300-gallon waste tank of local manufacture; a 1987 GMC Topkick with a 2,850-gallon tank fabricated by Andersen; and a 2001 Kenworth T800 with a 3,000-gallon Andersen tank, all carrying 250-cfm Jurop pumps.

The company's jetting utility truck carries a 1994 Guzzler Ramrodder jet rodder, a Roots PD Blower sewer jetter, a Myers pressure rodder and a 65-gpm. Myers high-pressure vacuum pump.

Water (non-potable for fire and road watering) tenders include a 1995 Kenworth T800 with a 3,200-gallon freshwater tank, a 1980 GMC with 1,500-gallon tank and a 1983 GMC Wildland 2-ton fire engine with all-wheel drive and an Andersen-built tank.

A CUES TV inspection trailer with generator hauls a ProCam DVD Ultra televising inspection camera and a Prototek AR-1 analog underground locator with a BuzzBox communications line locator.

Andersen also built a hand-wash trailer with four concession-type doors. Under each are sinks (12 total), mirrors, soap dispensers and a countertop. Walls are finished with fiberglass board. The unit has its own water system with

two heaters, powered by a 5,000-watt Honda generator. It sports lights and a self-contained graywater storage bladder to meet park requirements that contractors pack out whatever they bring in. The company just finished making its second mobile sink unit to service this year's fires.

These trailers carry 525 gallons of potable water for the sinks. Andersen refills it with a water tender and it's pumped by another contractor's graywater truck, unless Andersen has that contract, too. "Sometimes I keep my graywater trucks in the field during fire season, but often it's too much to keep track of, and I let that contract go to someone else."

Until he's able to create the proper balance of qualified help and equipment, Andersen is resigned to leaving money on the table. "I'm picky about our work, and it's quality first and the dollar second. I want to be able to hold my head high next time I see my customers." ■

MORE INFO:

CUES Inc.
800/327-7791
www.cuesinc.com

DRESSER Roots
877/363-7668
www.rootsblower.com

Guzzler Mfg. Inc.
800/822-8785
www.guzzler.com

Myers
800/472-0884
www.femyers.com

Prototek Corp.
800/541-9123
www.prototek.net

Flagg-Air Model 340

- 3450 rpm
- 1/4 hp, 115V
- Enclosed motor
- Stainless steel shaft
- High impact plastic parts
- Operates quietly
- 2-yr. warranty
- Fits in place of most original manufacturers' units
- Replacement parts available



The Flagg-Air 340 does not carry the NSF seal. Check local and state regulations for approval in your area.

MEDO HEM LA-80 Linear Pump



with low pressure alarm & light; with on & off switch

MEDO Piston



LA-60
LA-80B
LA-100
LA-120

SECOH Diaphragm



EL 60
EL 80
EL 100
EL 120

GAST

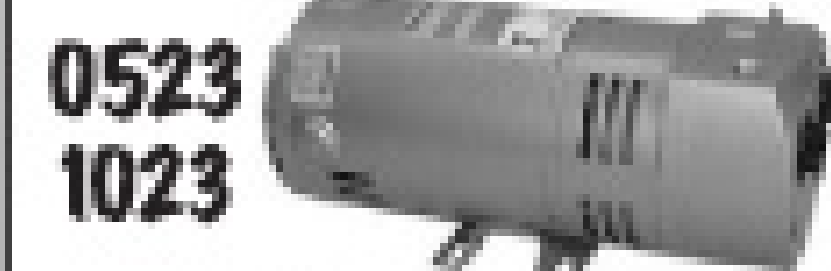

0523
1023

Rotary Vane Compressor

Regenair®

R3105-12 Blower

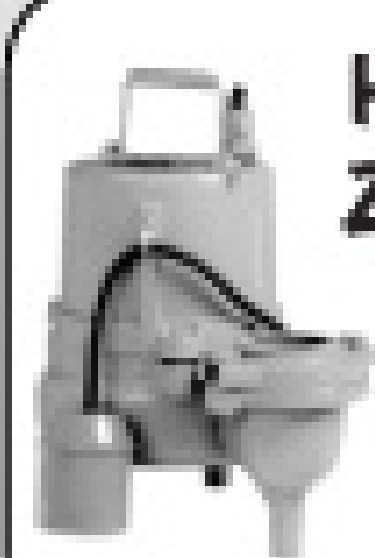

Hydromatic, Zoeller, ABS, Liberty & Myers Pumps

Conde SDS 6 Engine Driven

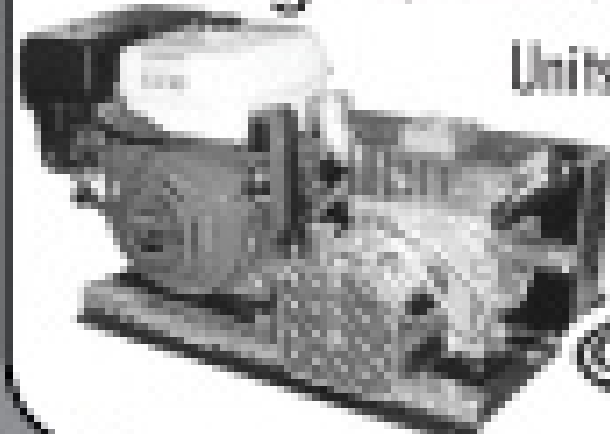

Units available 20 to 180 cfm



Moro PM80 Turbo 350 cfm

Moro Pumps: from 175 to 1642 cfm

Happy Holidays LIBERTY PUMPS

Booth 6095

We Carry a Full Line of **LIBERTY PUMPS** and Pre-Assembled Lift Station Packages



Omnivore LSG 200 Residential Grinder



280-Series Mid-Range Effluent Pump

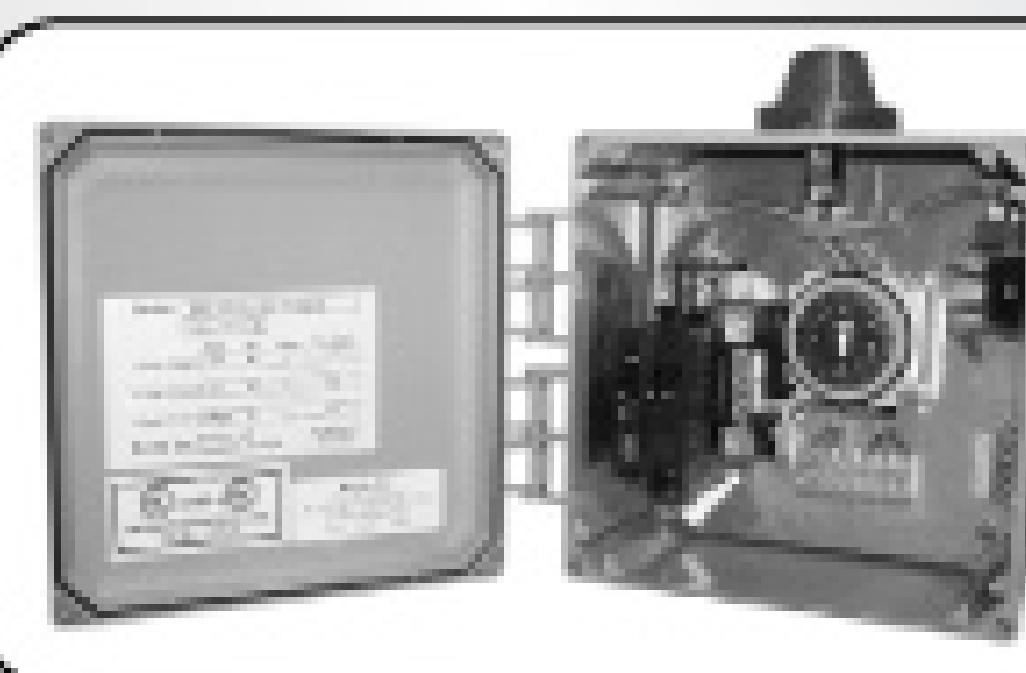

BIO Control Panel with Lift Station, Aerators, Timer & High Water Alarm

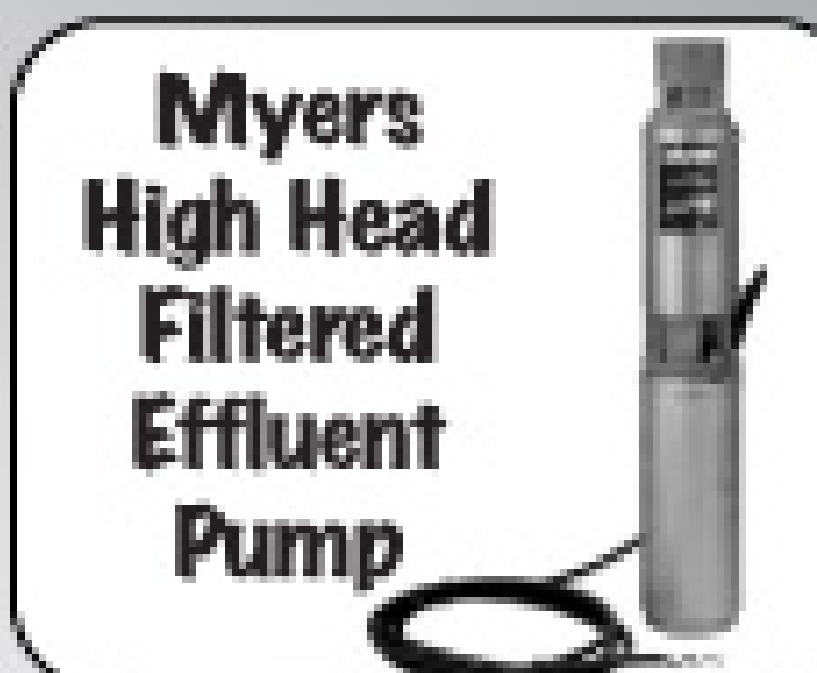

Myers High Head Filtered Effluent Pump



Septic Services, Inc.

toll free 1.800.536.5564 • 636.583.5564 • fax 636.583.6432
e-mail septic@fidnet.com • web www.septic serv.com



VACUUM TANKS - WE'VE GOT WHAT YOU NEED!



4,000 - 10,000 GALLONS

THE BEST ALUMINUM VACUUM TRAILERS IN THE INDUSTRY!

The solution for
ALL
of your vacuum
tank needs!

CALL US FOR A QUOTE TODAY!

Longhorn Tank Co.

800-422-9840 • FAX 479-787-6935

P.O. Box 1147 • Gravette, AR 72736

NUCONCEPTS

MANUFACTURER OF QUALITY PORTABLE RESTROOMS AND SINKS



Dual VIP Restroom Trailer

From \$9,841

Ideal for:

- Weddings / Parties
- Sporting Events
- Food Festivals
- Community Events
- Restroom Remodeling
- Movie Production

Features:

- Solar Powered
- Self-contained
- Flushing, china toilet
- Enclosed sink
- Power Converter (option)
- Air-conditioning (option)
- Interior Heater (option)
- Sink Water Heater (option)

1737 S. VINEYARD AVENUE • ONTARIO, CA 91761

PHONE 909-930-6244 • TOLL FREE 800-334-1065 • FAX 909-930-6237

www.NUCONCEPTS.com

SOFTWARE FOR THE INDUSTRY



**Business Efficiency
...NOW more than ever!**

Summit™ XP Service Profit Builder™

- Work Orders
- Job History
- Reminders
- Diagrams
- Dispatching
- Instant Mapping
- Inventory Control
- Receivables
- Automatic Credit Card Processing **NEW!**
- Commissions
- Repeat Business
- QuickBooks® Link
- ...and much more!

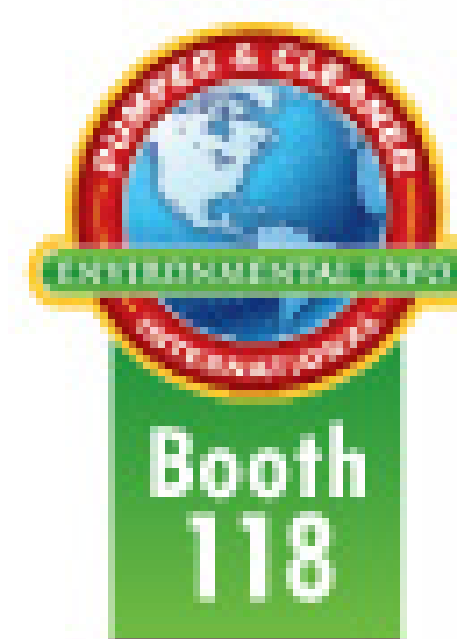

**Easiest to use!
...Over 25 years
experience**

Let us transfer the data
from your old program!

Stay on Top...with Summit™!

Ask about our other software programs for:

- Portable restrooms & other rental businesses
- Sales contacts for sales personnel
- Employee incentive tracking
- Fleet maintenance and service tracking

DEMOS ON LINE!...or call for a Demo DVD or personal guided tour



Ritam Technologies, LP

Sales: USA 800-662-8471 • Int'l: 208-629-4462
Email: info@ritam.com • Web: www.ritam.com

NO COMPROMISE



Masport
HXL400WV



FRUITLAND
RCF500F



GD Wittig
RFL100

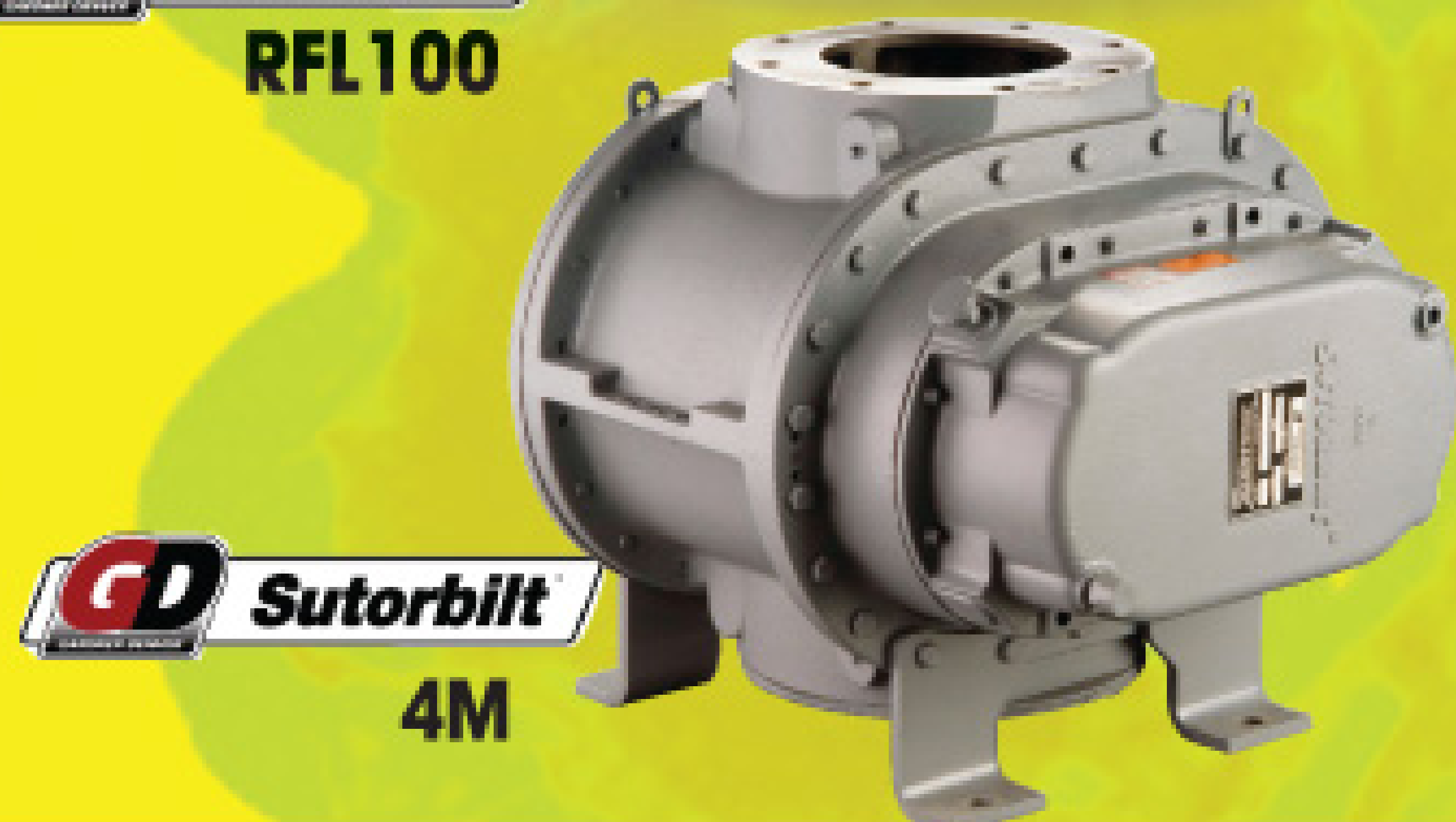

GD Sutorbilt
4M

At Armstrong Equipment, we believe life and business require certain compromises, but not on those things on which your business and family depend. A beautiful, new and shiny vacuum truck with a burned out pump is nothing more than uncomfortable transportation at four miles per gallon.

Your customers depend on you! Your employees depend on you! Your family depends on you!

We think you should be able to depend on **us!** That is why we sell the most dependable vacuum pumps, parts, valves and tank components available. When it comes to quality and reliability in the tools that make your business successful, there should be:

"No Compromise."

We proudly stock Masport, Fruitland and G-D Wittig vacuum pumps, Sutorbilt blowers, Garnet Instruments SeeLevel gauges, Clearflow Heavy Duty valves and most other vacuum truck components and accessories. We can also provide replacement pumps and repair kits for most major brands. For more information call us toll free at **800-699-7557.**

**ARMSTRONG
EQUIPMENT
INC.**

800-699-7557

11200 Greenstone Ave. • Santa Fe Springs, CA 90670

562-944-0404 • Fax: 562-944-3636

www.vacpump.com

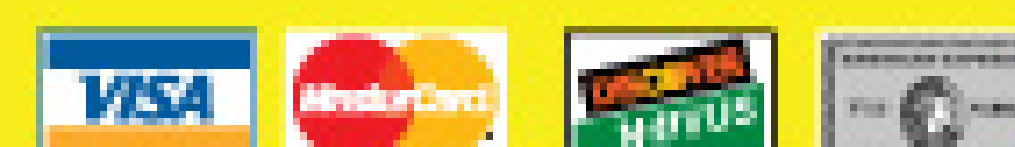

PORTABLE TOILET
SERVICE UNITS
SLIDE IN UNITS
HOISTED UNITS
ROLL OFF UNITS
CUSTOM UNITS

www.pikrite.com

pikrite

Manufacturing & Sales - 60 Pik Rite Lane - Lewisburg, PA 17837

1-800-326-9763



**Booth 4202, 4205,
4207, 4208**



SmithCo
SIDE-DUMP TRAILERS

SIDE DUMP

Call **800-779-8099**
www.sidedump.com

30902 C38
Le Mars, Iowa 51031

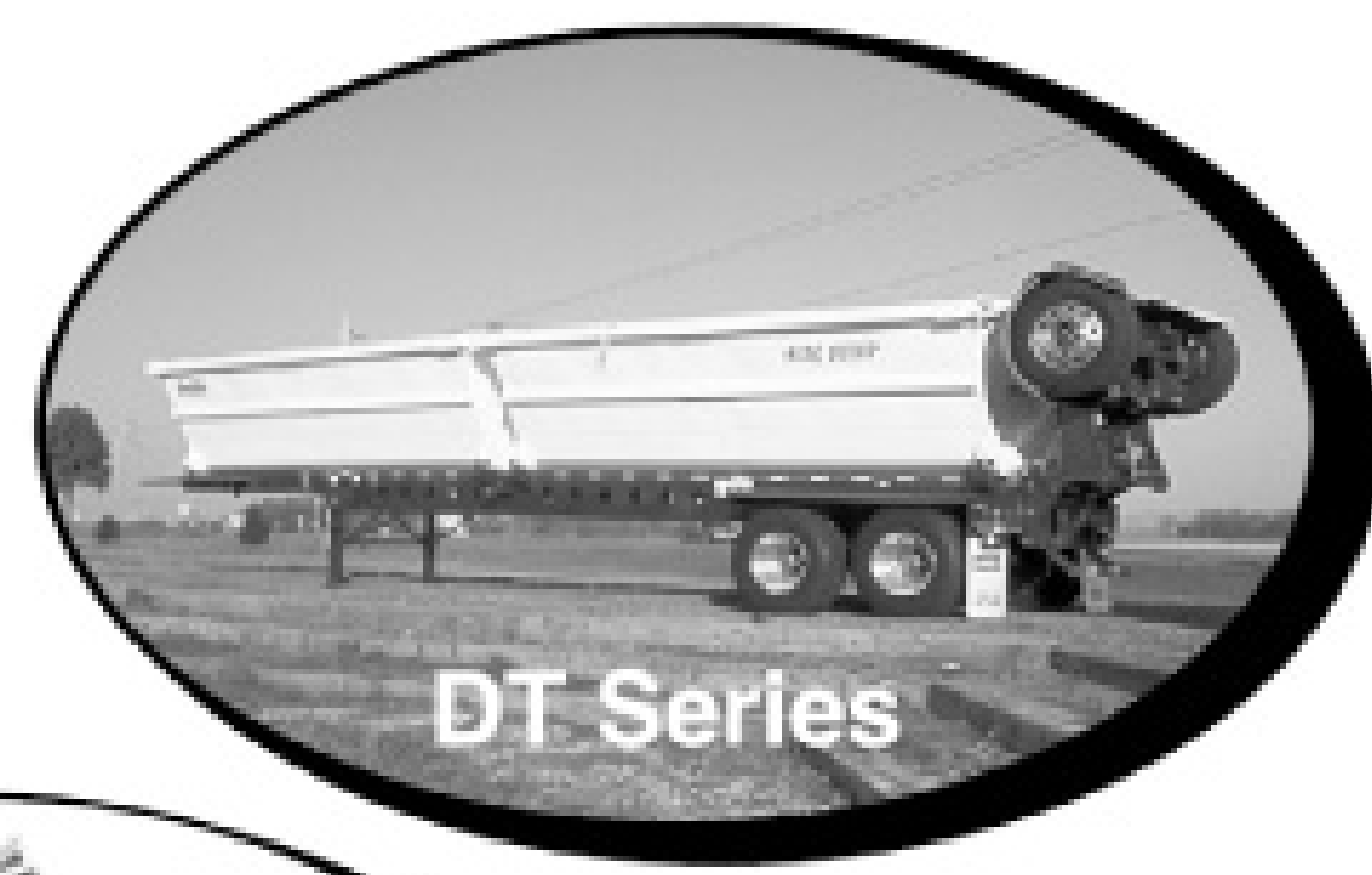

Booths 5219 & 6219

*Manure, Slurry, Sludge, Green Waste, Food Residuals, Compost, SmithCo Hauls it All.
Stock Pile, Spread, Stability, Selection, Service...SmithCo*

Art Blaster

Biodegradable Graffiti Remover Cleaner & Protector



Art Blaster takes off paint, pen, marker, tar, mildew, soap scum, grease, calcium buildup and many more substances from Portable Toilets.

Once applied, Art Blaster leaves behind a *protective sheen* that prevents new offensive graffiti ... even pencil wipes off!

User friendly Art Blaster --- Created to work hard so you don't have to.



Call our customer service team for more details.

1-800-345-3303
www.jjchem.com

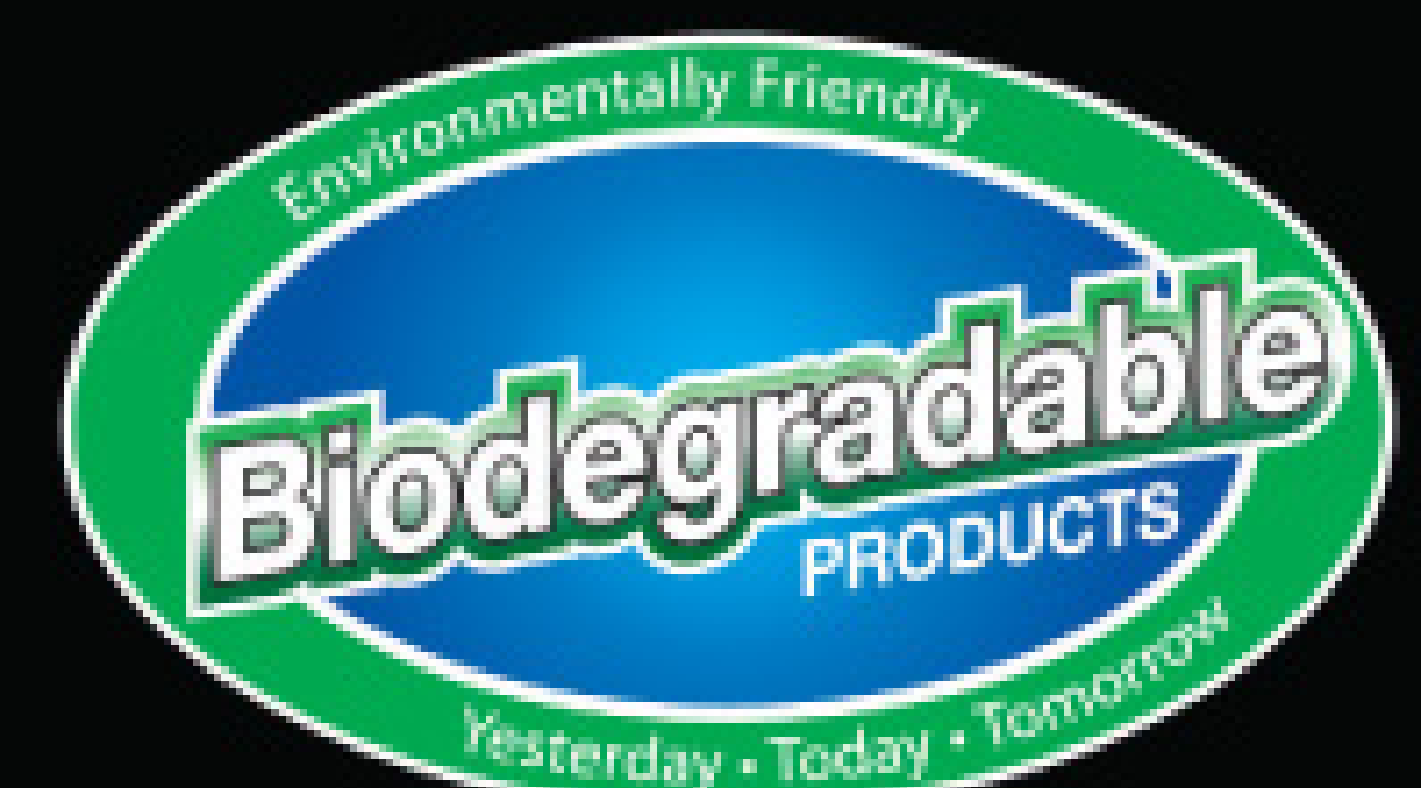

HOSE ASSEMBLIES

MANUFACTURED TO YOUR EXACT HOSE REQUIREMENTS BY THE LEADING SOURCE IN HOSE FABRICATION.



**LOWEST PRICES
GUARANTEED
ON ALL OF OUR**

"QUICK-SHIP"

ITEMS

INCLUDING
HOSE & ASSEMBLIES
COUPLINGS • VALVES • ADAPTERS



Booth 3137

Genuine

Kanaflex®

Assemblies by

ABBOTT

300EPDM HOSE NOW AVAILABLE IN COLORS

GREEN/BLACK - BLUE/BLACK - RED/BLACK

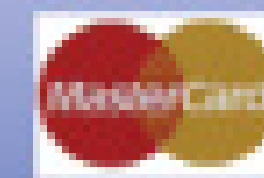

RUBBER COMPANY, INC.

1700 Nicholas Blvd. Elk Grove Village, IL 60007

www.pumperhose.com

1-800-852-1855 FAX: 847-952-0156

sales@pumperhose.com

MyTana

new

2C310

push camera system

inspection has never looked so good

show us your

MyTana Moments

YouTube

code: 2C310mm

call and ask about our new 2C310 and promotions: mention this ad

746 Selby Ave St. Paul, MN 55104

Toll Free: 800.328.8170

Fax: 651.222.1739

www.mytana.com



Booth 8089

Buy Now! BEAT The New Year Price Increase!

The Economic Stimulus Act of 2008

Allows Up To \$250,000

To Be Expensed In One Year.

Contact your tax professional for details.

ACT NOW!

Year-End SPECIAL!

Buy Now! Save BIG!

WE HAVE READILY AVAILABLE FUNDS



2500 Gallon Septic Tank

Masport HXL15 - 350 CFM pumping system, 6" discharge, (2) aluminum cabinets.

2008 Ford 750 260 HP Cummins, 6 spd manual, 33,000 GVW, air brakes,

\$85,977

Lease from \$1719 mo.



2008 Hino Model 338

260 HP 6 spd. trans., air brakes

2000 Gallon Tank

Masport HXL4, dual service, wash down, Tow package, toilet carrier.

\$78,975

F.O.B. Kansas City

Lease from \$1579 mo.



2008 Sterling Bullet

Cummins 305 HP, automatic transmission

1250 Gallon Tank

Masport HXL4, wash down, tow package & toilet carrier.

\$69,900

F.O.B. Kansas City

Lease from \$1205 mo.



2008 Ford 550 800 Gallon 300 Water / 500 Waste

Masport HXL4 pump, Burks DC10 Thieman 1,500lb. liftgate.

\$71,725

Lease from \$1434 mo.



Additional IN STOCK UNITS Available ...Call Today!

KeeVac

Industries Inc.

1835 W. Union Ave., Unit 1, Sheridan, CO 80110

NOT just a another broker.

We are a **Complete Sales & Service Center** Offering more than 50 years service experience.



Kevin Keegan
32 Years Experience

Call Kevin. Call Matt. ...Just Call KeeVac

866-789-9440

www.keevac.com

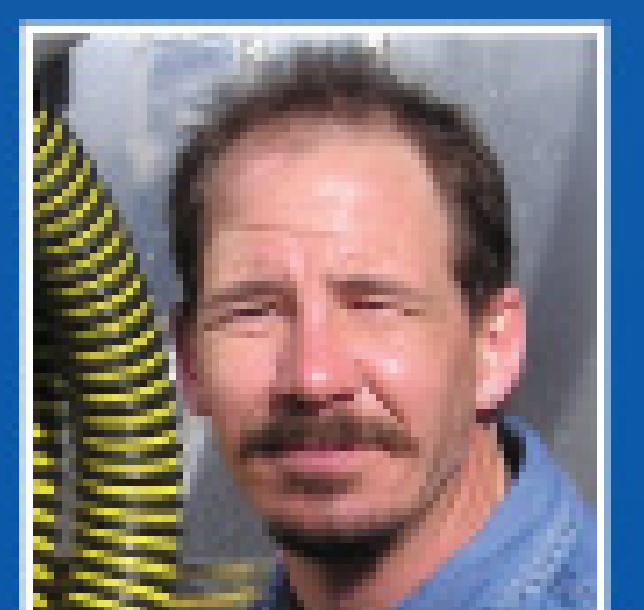

Matt Crowell
18 Years Experience

4

OF THE WAYS

Restrooms That Last 10 YEAR WARRANTY



Deodorizers That Work EARN FREE RESTROOMS



SAFE T FRESH
Deodorizers

Protection That Pays™

WE SAVE YOU MONEY

Dependable Trucks CONFIGURED TO YOUR NEEDS



www.satelliteindustries.com

Support After The Sale IN PERSON AND ONLINE

It's easy to say we can save you money, but how do we prove it?

Satellite/Synergy World restrooms have a ten year warranty, which is the best in the industry. We warranty our restrooms for ten years because we know they will last and cost little to repair. Proof enough?

Safe-T-Fresh deodorizers, with our exclusive ROI Rewards Program, is your ticket to earning FREE Restrooms. Earn points with each purchase and cash them in for FREE restrooms. A free restroom lasting ten years generates over \$8,000 in revenue. Our customers consider that a pretty good savings.

Finally, we invest in our customers by having Area Managers in the field, a full staff of customer service representatives and online, 24 hour access, for ordering and all your account information. We provide this support because your time is valuable.

If you like saving money, call Satellite or your Area Manager for more information.

800-328-3332



SYNERGY WORLD



Imagine The Possibilities

POWERFLO

PRODUCTS INC.

800-758-4788
 Vacuum Pumps & Tank Parts at
WHOLESALE PRICES!

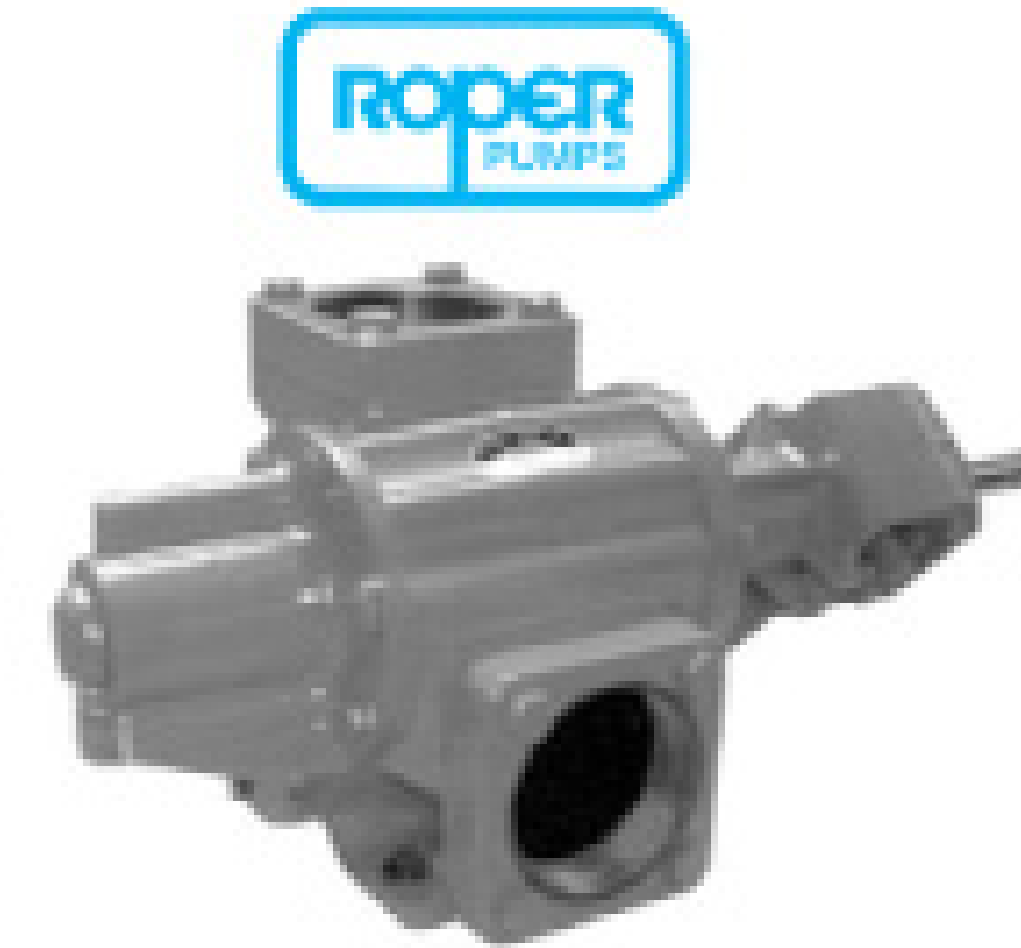
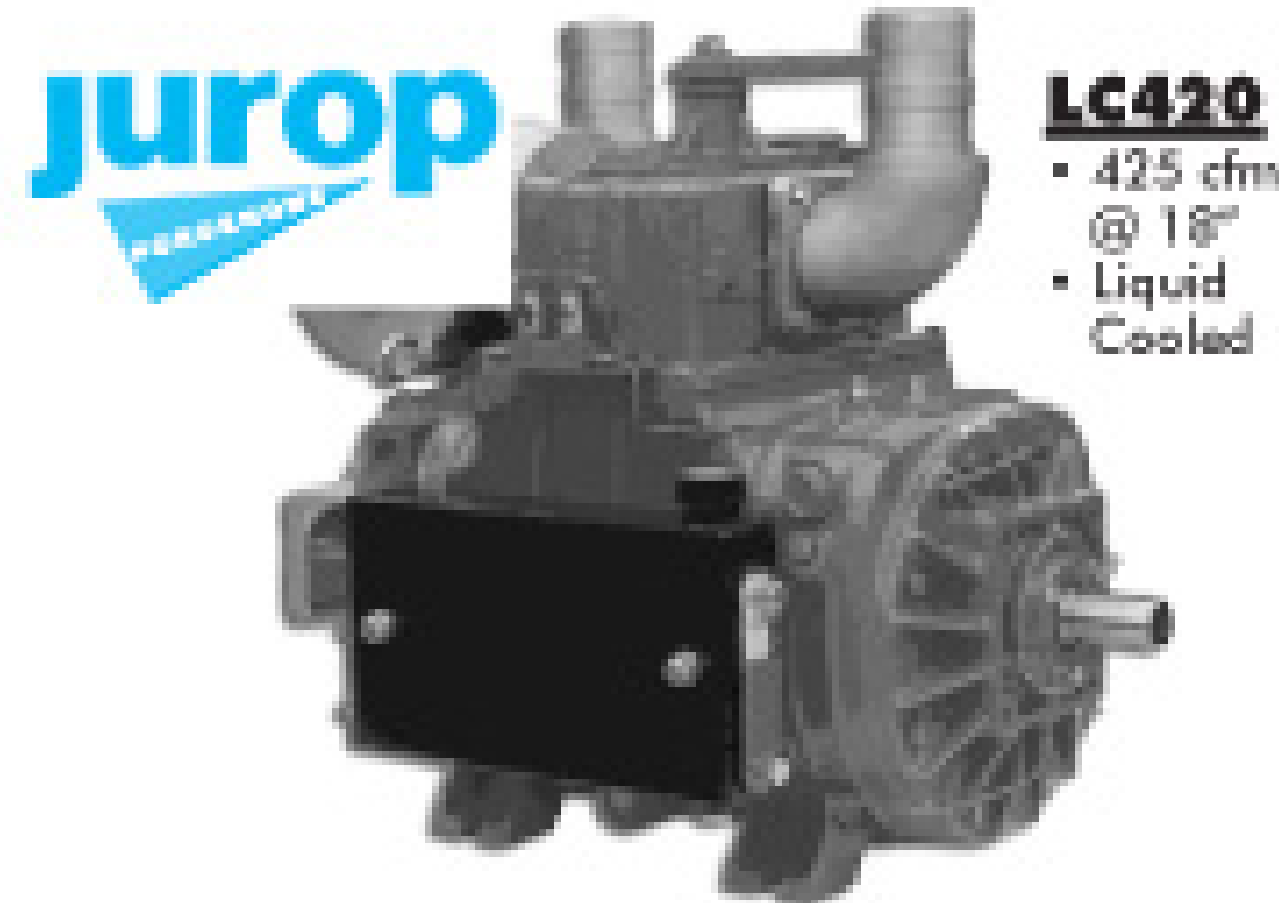

**CALL
 FOR YOUR
 DISCOUNT!**

PUMP VANES

**BULLET-PROOF
 your pump with
 KEVLAR BLADES**



DURA FLO BLADES

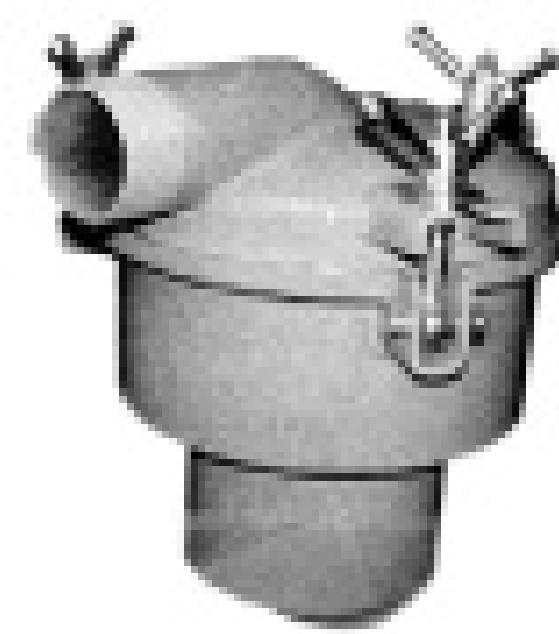

**Lever Action
 Gate Valve**
 Brass
 3" - \$98
 4" - \$157
 6" - \$288

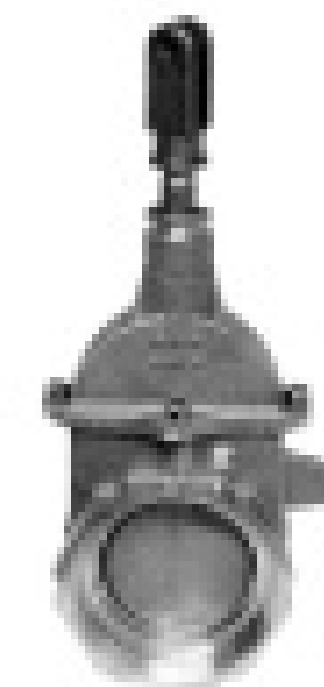
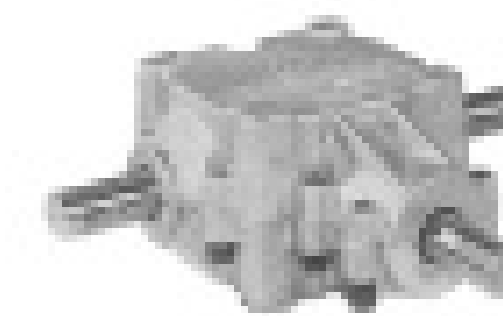
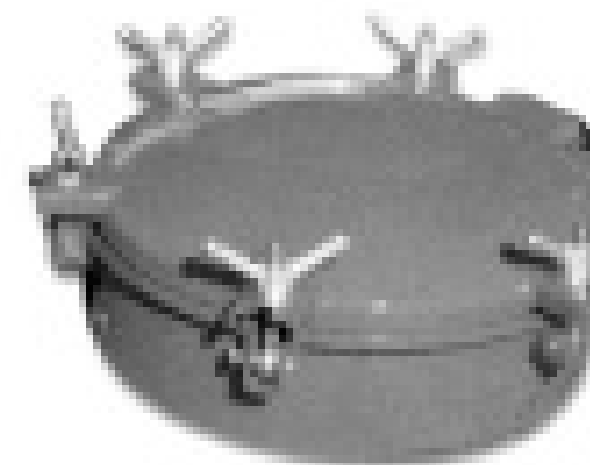

POWERFLO PRODUCTS INC. • 2755 N. Gaviota Ave. • Signal Hill, CA 90755 • Phone: 562-997-0720 • Fax: 562-997-0724



Aqua-Zyme Disposal Systems

*"From the Grease Trap to the Garden"
 - Dewatering & Composting -*

#1 Box on the market!

The ADS Dewatering System

is built by a pumping company for pumpers. You are welcome to come and watch the 30 yard box dewater 20,000 gallons of grease trap waste and/or septic tank waste in only 2 hours!

By using the ADS dewatering system along with our Compost Facility, we have turned our disposal costs into a profitable venture!

Call 979-245-5656 for Info!
\$ Financing Available \$

P.O. Box 489, Van Vleck, TX 77482 • www.aqua-zyme.com
 1-979-245-5656 • zymme@aqua-zyme.com • U.S. Patent # 6,364,122

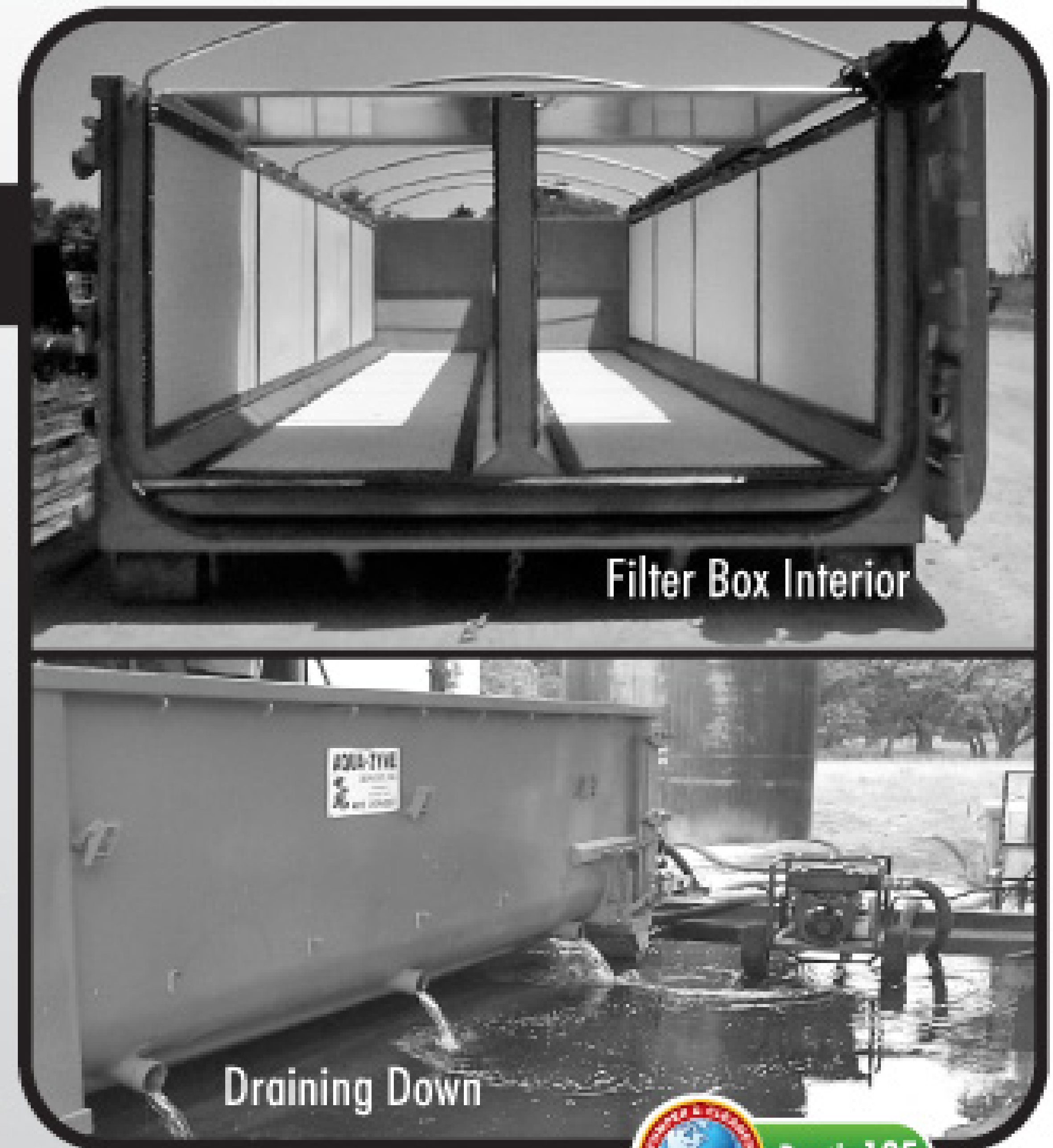

BUY IT NOW! \$99*

Per month until June 2009, thereafter regular payments for 60 months with no residual buyout at the end. *Ask us for details.*

'Guaranteed Credit Approval'

2000 Gallon Restroom Tank - Dual Service

Masport HXL4 standard pumping system, upgraded with (2) Hannay reels, diesel flush.

2009 Hino Model 268 Auto., transmission, air brakes, exhaust brake, stainless wheel simulators. **\$85,800**



As Low As
\$1,700
monthly

As Low As
\$2,720
monthly

3600 Gallon 'Roll-Off' Septic

Masport HWL400WV, Stellar 40,000# Hook Lift

2008 Freightliner Cummins ISC 300 HP Diesel Engine, 9-speed, 16,000# Front Axle / 40,000# Rear Axle

\$136,000 Plus FET



As Low As
\$2,978
monthly

4000 Gallon DOT 407/412

Front Hoist w/ Full Opening Rear Door

200 Gallon Non-Code Second Compartment

Masport HXL400W, 4.5 GPM 3000 PSI Jetter

2008 International 7500 Series 350 HP, 10-Speed trans., 18,000 # Front / 40,000 # Air Ride Rear

\$148,920 Plus F.E.T.



As Low As
\$1,719
monthly

2500 Gallon Aluminum Tank

360 CFM Pump, Hot Shift P.T.O. w/remote, 60" Tool Box.

2008 Ford F750 25,999 GVW diesel engine, automatic transmission, air brakes.

\$85,977



As Low As
\$1,130
monthly

7000 Gallon Trailer

5454 Aluminum- 3/8" heads, Full length hose trays, (2) ladders, rear bumper, 6" discharge - 4" inlet, Hendrickson air ride.

\$56,500 Plus FET F.O.B., Arthur, IL



think When you THINK of QUALITY tank trucks...

QUALITY THINK of Tri State Tank.

800-971-7657

www.tristatetank.com / email us from our website

636 Adams St. Kansas City, KS 66105

Septic. Grease. Oil. Restroom.

vacuum tank trucks

Santa Claus is Coming to Town

Longtime Illinois pumping and sewer repair contractor Danny Bland spreads Christmas cheer

Thanksgiving through Christmas is the busy season for Danny Bland of Bland's Sewer and Water in Alton, Ill. He's not busy maintaining pipes, however, he's busy maintaining hearts — including his own — by playing Santa Claus.

"This will be my 15th year," Bland says. "I've been playing Santa since my beard turned white. I wanted to do something for the kids and I enjoy this so much. No amount of money in the world can pay for how I feel when I get that feeling in my heart."

The 62-year-old with the 6-inch white beard refuses to take any pay for playing Santa; he says commercial jobs "take away from Santa Claus." But he keeps busy eight to nine hours a day in December, from 6 a.m. appearances at daycare centers to community Santa breakfasts, appearances at elementary schools and Christmas parties for the elderly at nursing homes.

It all started when the Exchange Club of Alton, a service club Bland belongs to, needed someone to pinch hit for the jolly one at its annual Christmas party for local children.

"My buddy did it one year, but he didn't have a very good beard, so that's how I got started," he says. "Kids always pull on my beard and say, 'you are the real Santa.'"

The belly like a bowl full of jelly is also real, Bland says, but he has to wear a white wig under his red hat because he's a little short on real hair.

CHANGING TIMES

Bland's business, like his Santa activities, started small and grew through the years.

"I've been in business 43 years," Bland says. "I started it when I was 19 years old. I used to do a lot of pumping, but we sold the pump truck about a year ago."

Alton has a population of about 30,000. It is across the Mississippi River from St. Louis, but Bland's 50-mile service territory is entirely in Illinois.

"St. Louis is close," Bland says. "But all different rules. And I never wanted to be the biggest, I just wanted to be the best."

Bland started the business after a back injury ended his college football career. He started with a trencher, then bought a backhoe and eventually got into liquid waste pumping. After four decades of pumping septic tanks, Bland sold his vacuum truck and today the company concentrates on service work, hooking up houses and some small commercial buildings to sewer lines and doing line repair and replacement work. The company works on about 10 houses a week, Bland says.

Danny Bland and his wife, Bonnie (top), share the holiday spirit with kids and grownups alike, including frequent visits to schools (below).



"Once all the houses get hooked up to water and sewer, there's not a lot of tanks left to pump," Bland says. "On the rare occasion we need someone to pump a tank — it's usually to fill it up with dirt because it's not going to be used anymore — we have a contractor we use."

SANTA'S HELPERS

Fortunately for Bland, his stepson Bill Ayres is in the process of taking over the business. His grandson, apprentice plumber Struther Griffith, and nephews Bill and Jason Bland also work for the company and all pitch in so he can devote the necessary time to playing Santa.

Bland's wife, Bonnie, sometimes accompanies him on his holiday-cheer missions as Mrs. Claus.

"I like going to the nursing homes the most," Bland says. "Those people still believe in Santa Claus when they are 80 years old or more. It's like they go back to their childhoods when they see me. They get to be kids again."

He says since Alton is a close-knit community, he has known many of the nursing home residents his entire life and can tell stories about them, which makes for good fun if they don't recognize him in his Santa costume.

"They are really amazed at some of the things Santa knows about them," he says with a chuckle.

Bland says he'll hand out presents at a nursing home Christmas party and then visit the residents who are unable to leave their rooms to attend.

"I insist on going to see the unresponsive ones too," he says. "I talk like Santa to them and they'll remember their childhoods and almost every time I get a big smile. The staff can't believe it."

Probably the most emotional visit Bland has had as Santa was at the home of an 8-year-old girl diagnosed with terminal cancer.

"When I left, I said, 'See you next year,' and she turned to me and said, 'Santa, I'm not going to be here next year,'" Bland says. "If that doesn't tear at your heart, nothing will."

OVERCOMING SANTA-PHOBIA

One might assume a guy who grew up to play Santa with so much conviction has fond childhood memories of the big fat man in the red suit. Not so, Bland says.

"I hated him when I was a child," he says. "I had three older sisters and five older brothers and they pulled tricks on me that made me scared of Santa."

Those memories, he says, are the key to his ability to get children over their fears today.

"I've been playing Santa since my beard turned white. I wanted to do something for the kids and I enjoy this so much. No amount of money in the world can pay for how I feel when I get that feeling in my heart."

Danny Bland

"I understand their fears. So I can get any child on my lap because I don't try to scare them," he says. "If a child is crying, I don't force it. I let them sit on the floor and watch. When they see the other kids aren't getting hurt and are getting treats, they come around."

Bland's activities to help children are not limited to the holidays. He owns a 320-acre farm 60 miles north of Alton where he raises elk and deer.

Several times throughout the year he welcomes groups of disadvantaged children to the farm through the Alton Boys and Girls Club and the Exchange Club of Alton, giving them the opportunity to fish

and hike. Sharing the country scenery and the animals with kids who might otherwise not have the opportunity to get out of the city is just another way the longtime businessman maintains his heart during his after-hours time. ■

After Hours is an occasional feature that describes how business owners reconcile work life with family, leisure time, charitable pursuits, and personal interests and passions. Pumper welcomes story ideas. If you take part in something interesting outside work, or if you know someone in the pumping business who does, please send a note to editor@pumper.com.

We Squeeze the Crap Out of Water™

Rotary Thickening and Dewatering

Simple systems that are totally enclosed, compact and easy to operate.



PH: 269-673-9559

www.primesolution1st.com

Made In USA

Built Better to Perform Better™

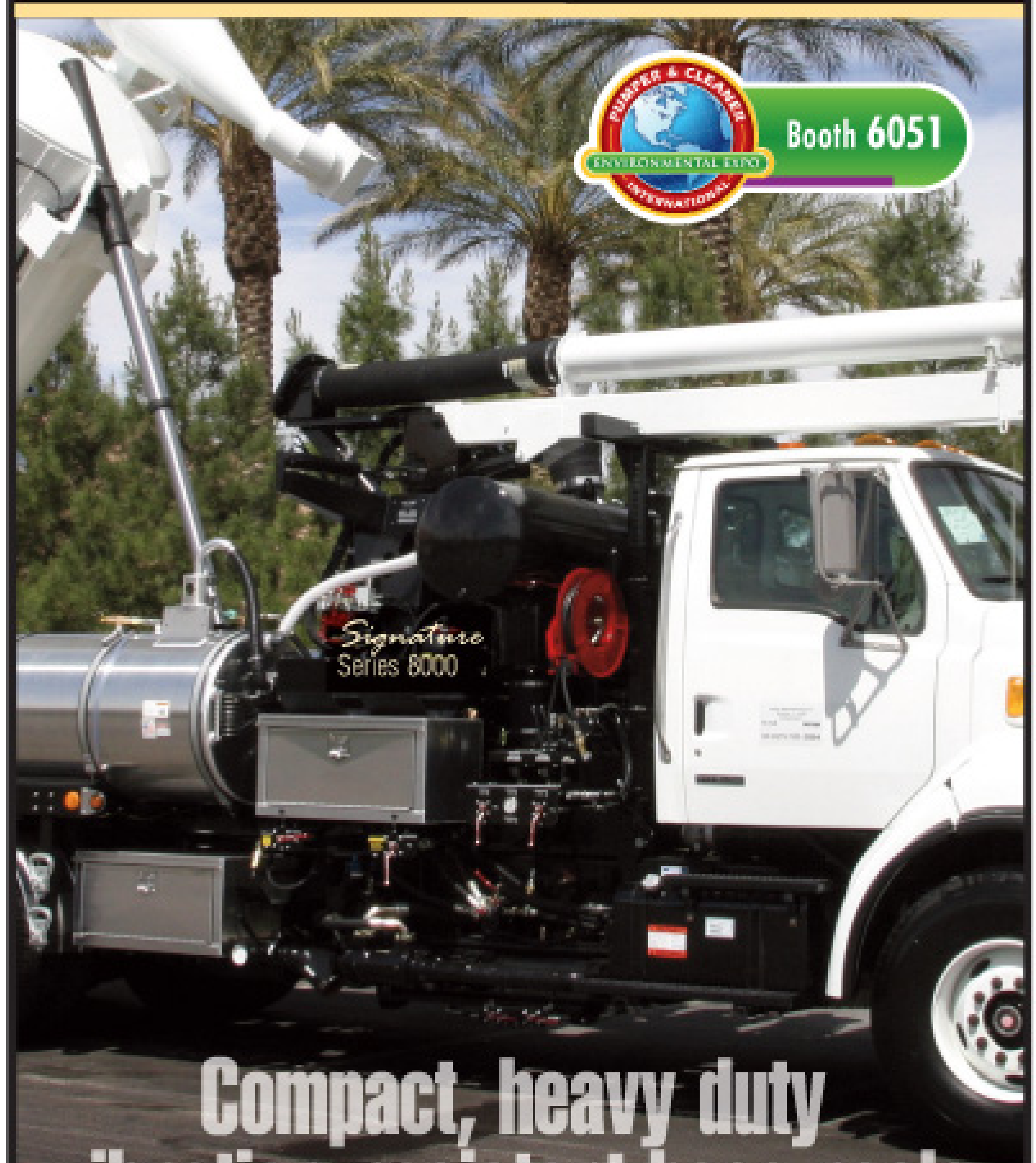

Compact, heavy duty vibration-resistant hose reels

Photo courtesy of Vetroc, a subsidiary of Federal Signal Corporation



Highest rigidity, ultra heavy duty cast aluminum Series 8000

Best in their Class Signature Reels

NEW!

Dual pedestal reel ideal for washdown, sanitizing

Patent Pending Series DP7000

800-444-3134

reelcraft.com/pumpercleaner

Made in USA



Wind Things Up With Reelcraft™



KNOW-HOW TO GET YOU MOVING

Now In **STOCK!** On-The-Lot Selection *Call For Prices & Pre-Approval!*



2007 Sterling 4200 aluminum tank, NVE 506 pump, PTO jetter 10 GPM, 3500 PSI 150 gallon water tanks 66000 GVW, 410 HP, 10 spd.

\$138,930 Plus FET



2007 Sterling 2500 gallon Steel Jurop pump, Mercedes 260 HP, 10 spd, engine brake, traction control ALUMINUM HOSE TRAYS.

\$76,500



2002 Sterling with new 2500 gallon tank, 210 HP manual trans, Jurop pump.

Call for price and details.



Booths 5207 & 6209



New Tandems are coming in soon

Call for details

FREE DELIVERY

Anywhere in the lower 48 in December.

We Have Financing Available!

Call Us Today Toll-Free:

888-201-9166

www.badgertruck.com

Septic - Portable Toilet - Hoisted Vacuum - Slide-Ins
New! Units Available / Trade-ins Accepted! / Financing & Lease Plans



Thanks to all our customers. May you have a safe and happy holiday season!

— Ardy

Prototek 800-541-9123

ECONOMICAL • EASY www.prototek.net email: prototeksales@prototek.net

Del Vel Chem
 COMPANY

Offering a Complete Line of All Natural Portable Toilet & Septic Needs

Our All Natural Products EXCEED the Green Seal Standards to Better Protect Our Environment

We feature the following all natural products:

- Eliminator Nano Emulsifier—Environmentally friendly emulsifier-deodorizer.
- Graffiti Remover—Environmentally friendly all natural graffiti remover.
- Nev-R-Freeze—The all natural no VOC's portable toilet anti-freeze. Great for hand washing stations.

Ecological SAFE Alternative To HARSH CHEMICALS

Serviceing the Industry with Pride Since 1994
 250 Old Marlton Pike • Medford, New Jersey 08055
 800-699-9903 • Fax: 609-714-3030 • www.delvel.com

Strong like bull.



The most durable and affordable restroom available, the Global from Hampel.

No bull.

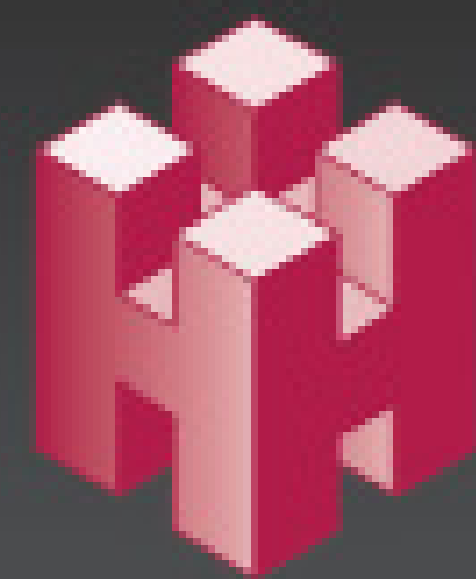

Hampel

Engineered for strength, durability and value.

www.hampelcorp.com • 800-549-1558

CAPITAL RUBBER CORP

Get Connected.

WEATHERFLEX EPDM



3" X 20 FT \$85
 3" X 25 FT \$99
 3" X 33 FT \$125

COUPLINGS INCLUDED!

**WINTER SPECIAL:
 5% OFF**

**WEATHERFLEX
 ORDERS OF 150 FT
 OR MORE!**

JETTER HOSE ASSEMBLIES

WINTER SPECIAL:

**5% OFF
 ALL STOCK
 JETTER HOSE
 ASSEMBLIES!**



POWER BOOSTER

INCREASE VERTICAL LIFT



**PUMP DIFFICULT JOBS WITH EASE
 LIFT HEAVY SLUDGE AND WASTE
 REDUCE PUMPING TIME & LABOR
 GET MORE DONE IN A DAYS WORK**

**FREE 50 FT AIR HOSE
 WITH POWER BOOSTER PURCHASE!**

9906 SMOOTH RUBBER VAC HOSE

COLD WEATHER FLEXIBILITY!

WINTER SPECIAL:

**4" X 10 FT DUMP HOSE
 \$105**

FEMALE CAM X OPEN END

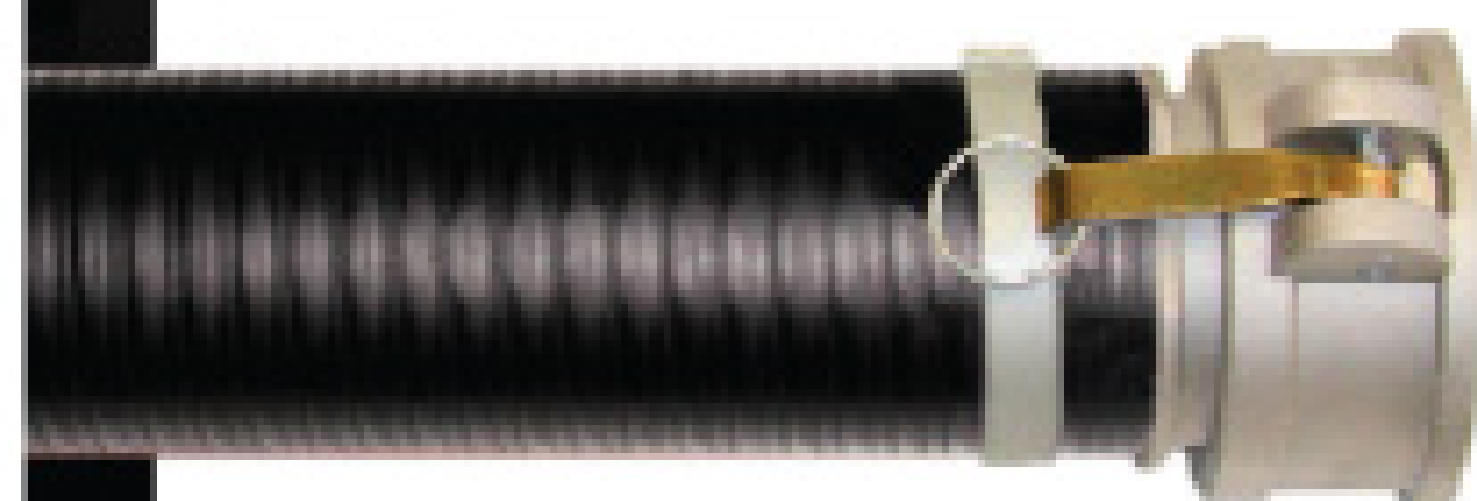

845 N DILLON DRIVE
 WOOD DALE, IL 60191

(800) 258-3000



WWW.CAPITALRUBBERCORP.COM

JAG

Mobile Solutions

**Are you ready for winter?
 JAG Mobile Solutions is.**

**With comprehensive heat packages
 available now on all JAG units,
 your JAG mobile restroom will
 keep your profits warm all winter long.**

Immediate Availability on Most Models

Mobile Restrooms • Shower Trailers • Custom Combinations

(800) 815-2557
www.jagmobilesolutions.com

Booth 7131

PORTA LISA

\$ We've Got the Money \$

For All Your New and Used Equipment Needs

Chuck Territo

Mike Rausch

- \$250k Application Only
- Simple Approval Process
- Lease or Loan Options
- New & Used Equipment
- Flexible Finance Options
- Start Up Programs

Let us put our 35 years of experience to work for you! Call today and see why...

It pays to lease with us!

Booth 7104

Granite Leasing Co.

800.246.7997
www.graniteleasing.com

Advance

PUMP & EQUIPMENT INC



**Custom
Pump
Trucks
Built to
Your Specs**



2800 Gallon Aluminum Tank
In Stock For Quick Delivery

**Call Today
For
Professional
Blower
Installation**



NVE
DISTRIBUTOR

**6000 Gallon
Short Tanker Trailer**

- Excellent for Septic & Grease Trap Service.
- Call for more Information

Less Trips = Less Fuel

Introducing the JT530
\$4,250.00

**Take An Extra
10% Off**

Tool box Jetters

Expires December 31, 2008

Add Jetting

To Your

Pump Truck

or Tanker Trailer

Introducing the JT1030
\$5,995.00



Toolbox Jetter JT530

- Polished Aluminum Toolbox
- 5 GPM @ 3000 PSI Water Pump With Pulsator
- Electric Start Engine
- Remote Fuel Tank
- Electric Rewind Reel With 200' of 3/8" Hose
- Chrome Guide Rollers On Reel
- Washdown Gun With Quick Connect Tips
- (1) Jet Nozzle
- Stainless Tool Rack

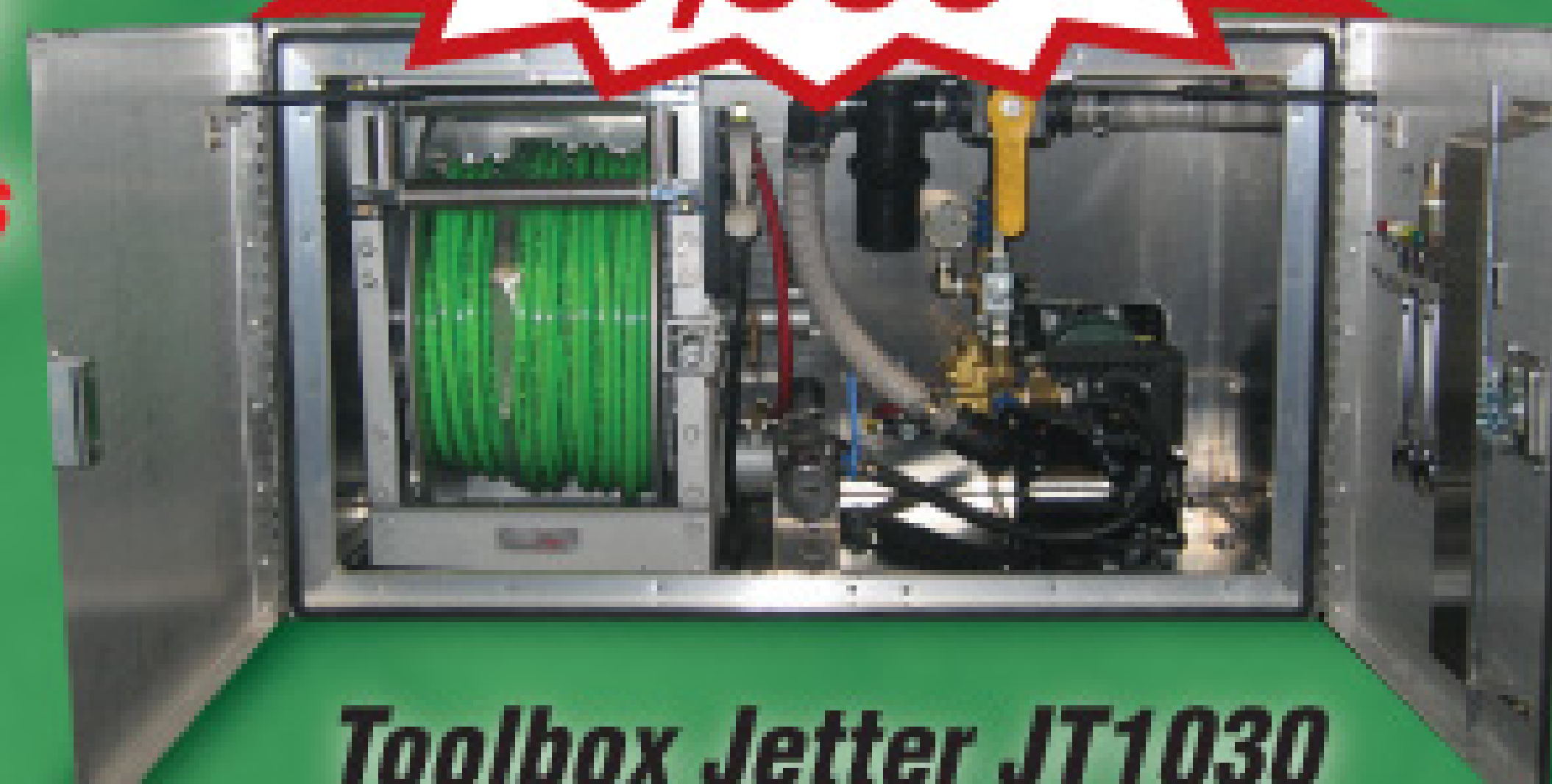

Toolbox Jetter JT1030

- Polished Aluminum Toolbox (28 x 28 x 48)
- 10 GPM @ 3000 PSI Water Pump w/Pulsator
- Gearbox Drive - Standard or optional Hydraulic Drive
- Bucket Fill/Drain
- Air Rewind Reel w/200' of 1/2" Hose
- Chrome Guide Rollers on Reel
- Wash Down Gun w/ (4) Quick Connect Tips
- Jet Nozzle - Flushing
- Includes Mounting Brackets

Toll-Free 1.877.557.PUMP (7867)
"Partners in Performance"

Call For A Quote Today!

www.AdvancePump.com

15418 Old Highway Road • Peosta, Iowa 52068
877.557.PUMP (7867) • Fax: 563.557.0961



Lely Waste Solutions, LLC

Temple, TX | 800 367 5359

**THANKS TO
TEXAS OUTHOUSE INC.**



**THANKS TO
RUIDOSO SEPTIC**



Temple, TX
800 367 5359
Fax 254 938 7204

www.lelywaste.com

Bruce Curry
bcurry@lelywaste.com
Earl Ballard
eballard@lelywaste.com

FACTORY AUTHORIZED SERVICE

for: *ROOTS-DRESSER, ROBUSCHI, HIBON, H&H, HOLMES and KAISER Blowers*

**Fast Delivery - Large Selection - Best Price - Great Service
New - Rebuilt - Core Exchange**

**Exchange Units - Most Models
of Roots, Robuschi, Hibon,
Holmes, H&H and Kaiser**

- ◆ Roots 1125 Trinidad
- ◆ Roots 1021 DVJ
- ◆ Roots 1024 RAS
- ◆ Roots 1021 RAS
- ◆ Roots 824 RCS
- ◆ Hibon SIAV 840
- ◆ Hibon SIAV 8702
- ◆ Hick Hargreaves 4084



**New Blowers & Pumps
Available From POWER VAC**

- ◆ Roots
- ◆ Robuschi
- ◆ Hibon
- ◆ Hick
- ◆ Masport
- ◆ Moro
- ◆ Aerzen



hibon  **KAISER**

ROBUSCHI

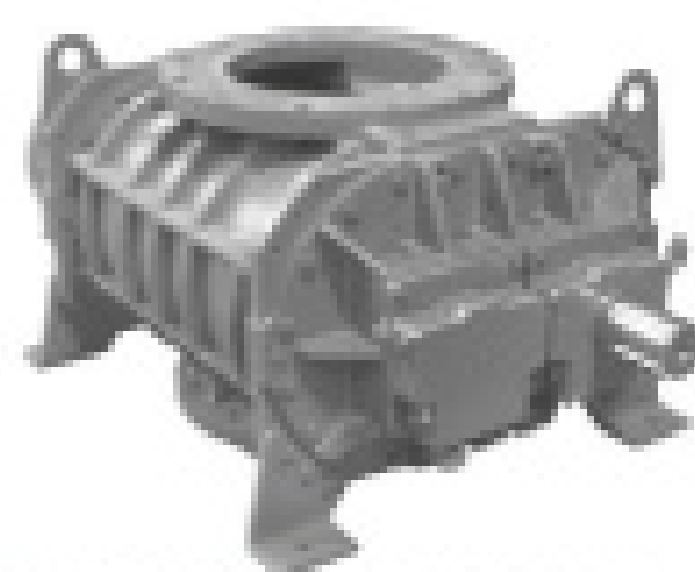
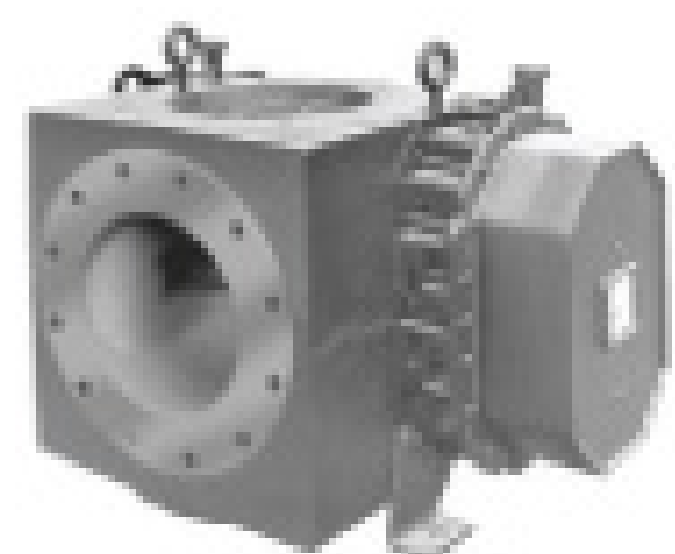

1-800-822-4887

W228 N2792 Duplainville Rd. • Unit G. • Waukesha, WI 53186
(262) 542-8989 • Fax: (262) 542-6262 • www.powervacinc.com

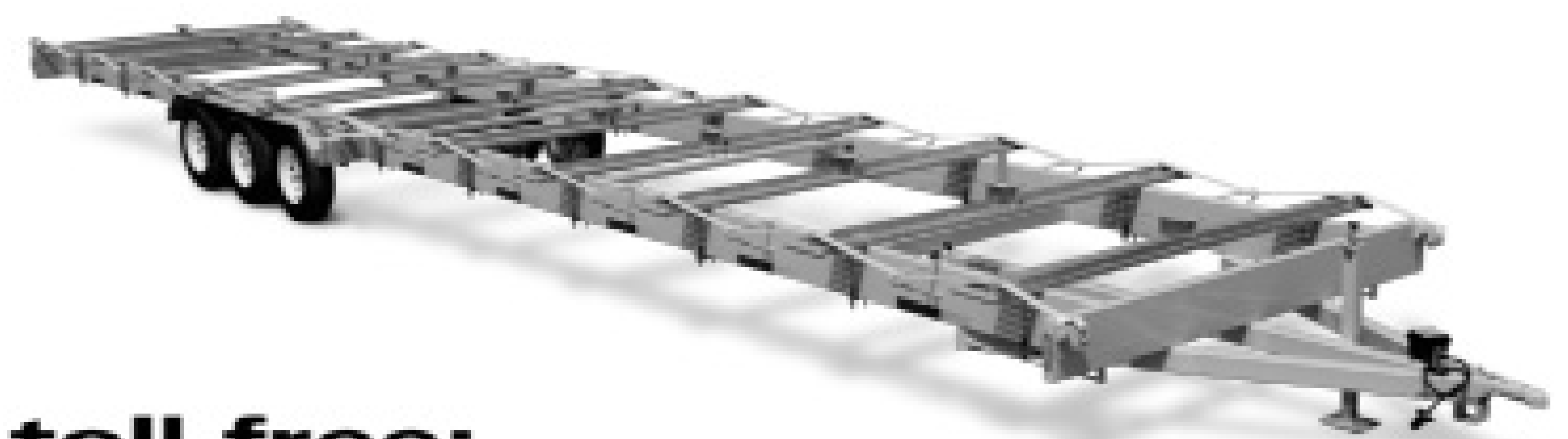

**toll free:
(866) 457-5425**

EXPLORER Toilet transporters



**Secure Transportation
for portable toilets with
wooden or plastic skids!**

POSI-STRAP

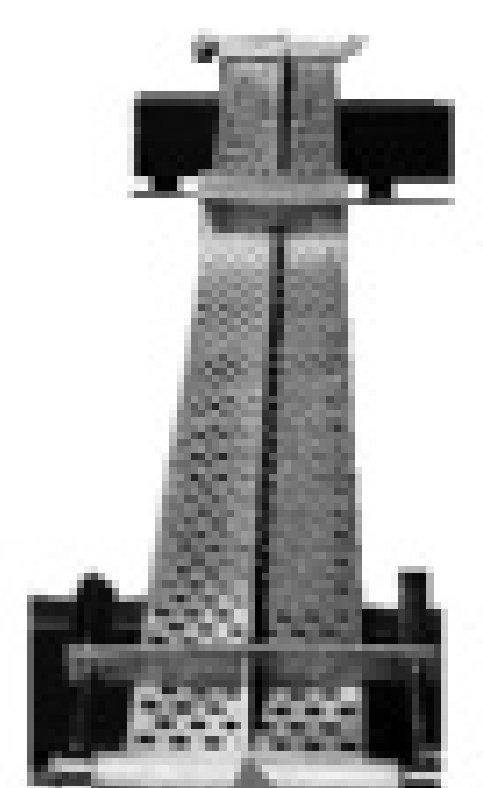

POSI-CLAMP

Distribution Centers

California

Plumas Sanition
Tel: (530) 832-0370
Fax: (530) 832-0370
Portola CA

Colorado

Columbia Sanitary
Tel: (303) 526-5370
Fax: (303) 526-9686
Golden CO

Texas

Woyl Enterprises
Tel: (903) 586-6493
Fax: (903) 541-0874
Jacksonville TX

Florida

Steve Baie Enterprises
Tel: (407) 709-8175
Fax: (407) 822-3598
Apopka FL

Alberta

Ted Hoover
Tel: (403) 946-4108
Crossfield AB

Manufactured by:

McKEE TECHNOLOGIES INC.
ELMIRA, ONTARIO, CANADA N3B 2A1

visit us on the web
www.explorertrailers.com

END OF YEAR TAX SALE!

LOWEST PRICES OF THE YEAR!

NEW PRODUCTS!

HEATED COLLARS FOR YOUR VALVES
SCRAPERS, SPOONS & HOES- WE GOT EM!

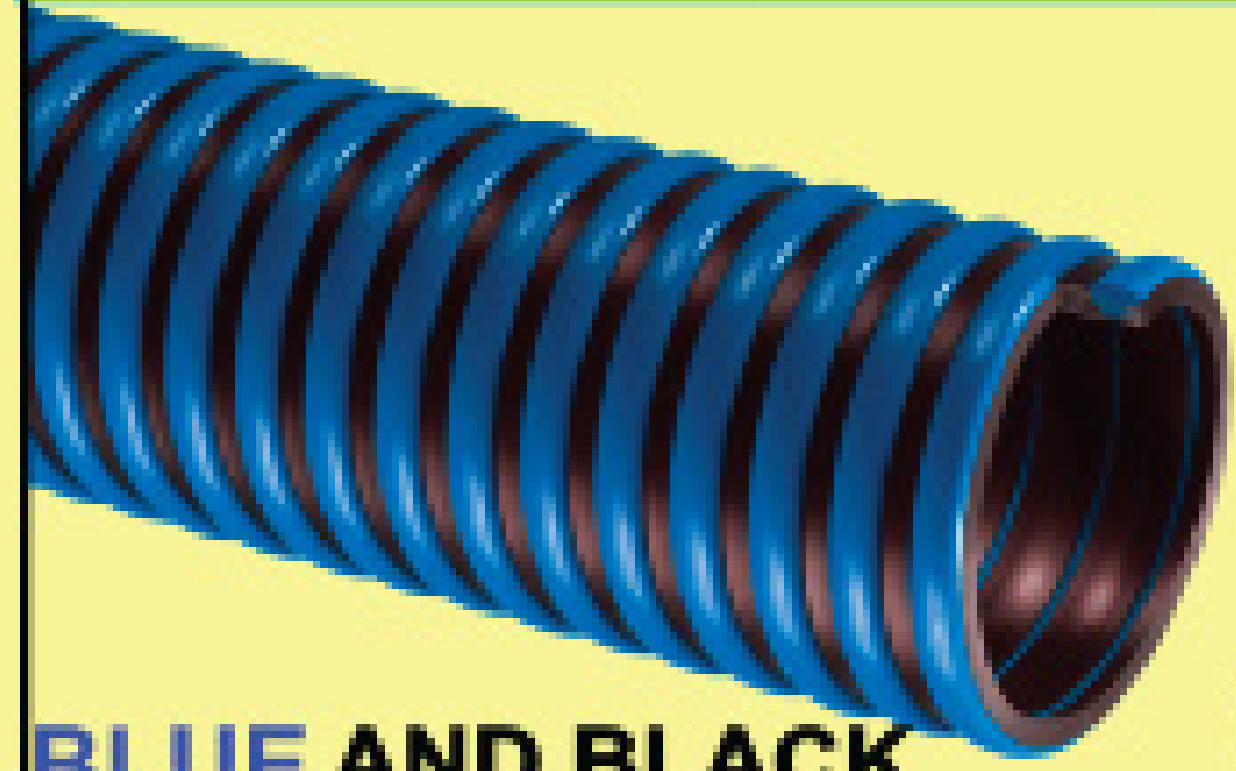

BLUE AND BLACK

BUY BULK AND SAVE!

EPDM SUCTION BULK
100 FT ROLLS



GET IT IN COLORS
SAME LOW PRICE

2"	3"	4"	6"
\$1.75	\$2.99	\$5.50	\$10.95
\$1.59	\$2.75	\$4.95	\$10.75

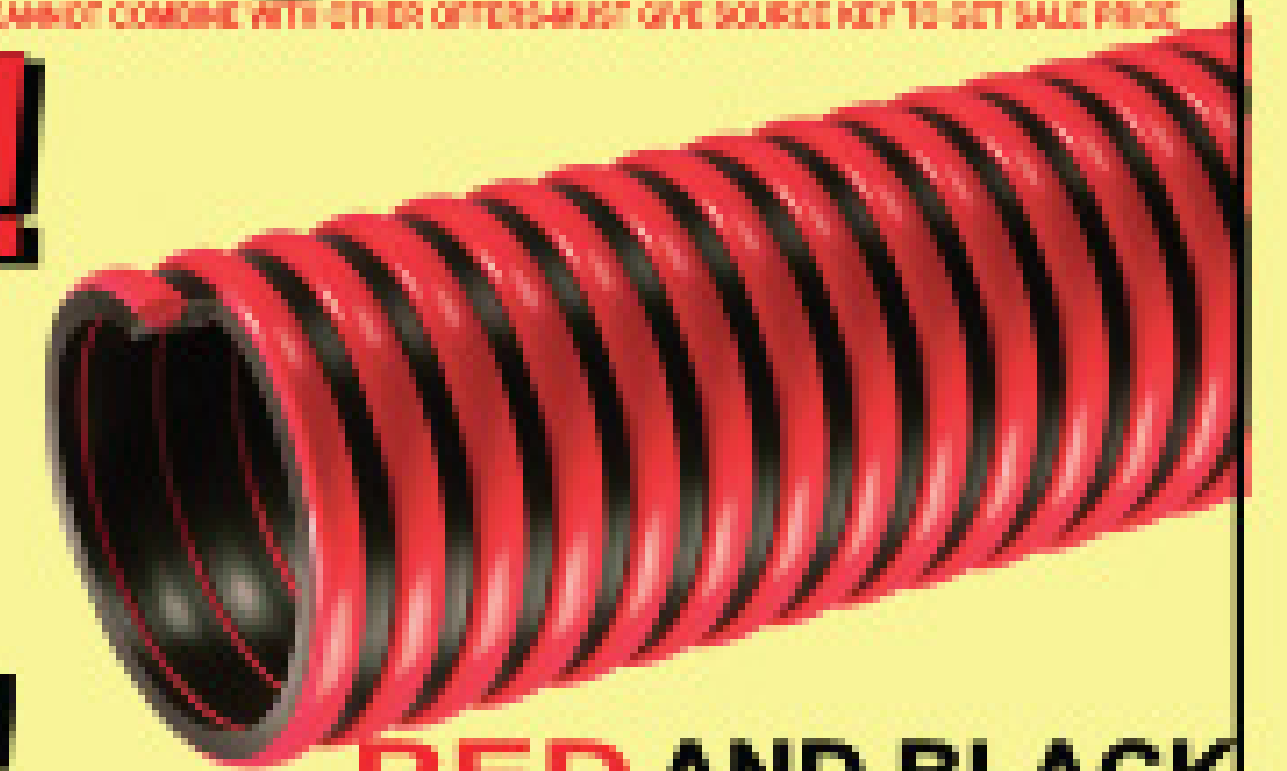

RED AND BLACK

OVERSTOCKED!

HONDA 8HP MOTOR

- GX240 - 8 HP
- ELECTRIC START
- INCLUDES RECTIFIER - CONVERT AC TO DC

\$1310.50



WHILE THEY LAST! \$799.95

EPDM SUCTION CPLD
M X F QUICK CONNECT



GET IT IN COLORS
SAME LOW PRICE

INCLUDES
FITTINGS!

3" X 20'	\$84.95	\$79.95
3" X 25'	\$101.95	\$94.95
3" X 30'	\$117.95	\$109.95
3" X 33'	\$129.95	\$119.95

TIGER TAIL CPLD M X F



INCLUDES
FITTINGS!

2" X 25'	\$91.70	\$82.95
2" X 30'	\$108.70	\$97.95
2" X 35'	\$125.45	\$112.95
2" X 40'	\$142.20	\$127.95

VALVES

LEVER VALVES

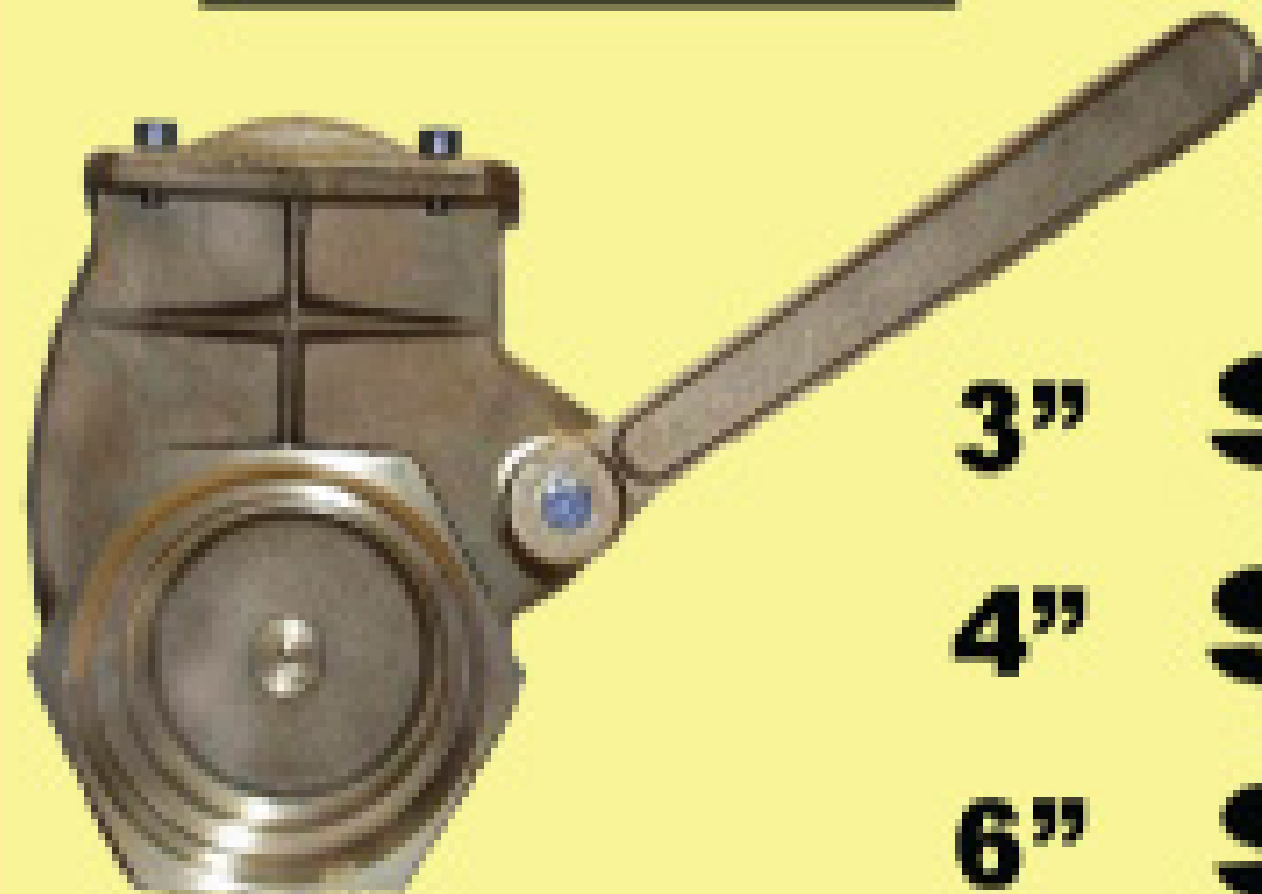

SALE!

3"	\$99
4"	\$145
6"	\$269

PUMPS

JUROP R260



- 363 CFM
- 18" CONTINUOUS DUTY
- BALLAST PORT COOLING
- AUTOMATIC OILER

2007 PRICE!

\$2695⁹⁵

ORDER WITH HOSE
TAKE AN EXTRA 5% OFF!
NEW PRODUCTS!

SAVE MONEY- PROTECT YOUR FITTINGS!

SAFETY LOCK

KEEP YOUR CAM
EARS CLOSED

2"	\$1.95
3"	\$2.50
4"	\$2.95

SAFETY BUMPS

COMFORTABLE HANDLE
SAFEGUARDS YOUR FITTINGS

2"	\$19.95 MXF SET
3"	\$29.95 MXF SET
4"	\$37.95 MXF SET



HOSE BREAKING OFF
AT THE TRUCK?
VARCO FLEXI-JOINT



~~\$51.99~~
\$47.95

COUPLINGS AND REDUCERS



100'S
OF
THEM!



FEMALE X MALE REDUCER



3" X 2"	\$17.85
4" X 3"	\$26.25
6" X 4"	\$45.95

VAC TRUCK ACCESSORIES

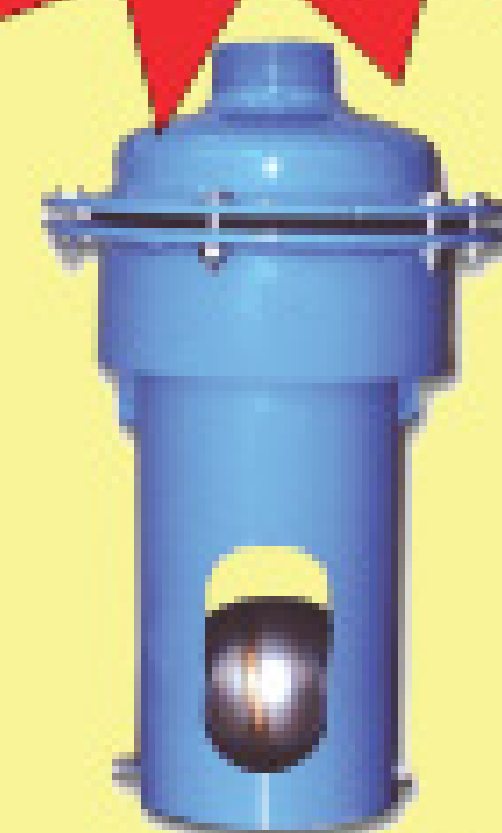

1 1/2" BRASS
VACUUM RELIEF

2" **\$173.25**
3" **\$173.25**



BRASS PRESSURE
VALVE

1 1/4"	\$29.95
1 1/2"	\$35.95
2"	\$45.95



VACUUM PRESSURE
GAUGE

- 0-30 Vacuum
- 0-30 PSI
- Liquid Filled
- 1/4" Male NPT

2.5" Face **\$12.95**
4" Face **\$39.95**



2" **\$173.95**
3" **\$235.95**



TIGER TAILS

SALE!

2" X 36" **\$19**
3" X 36" **\$28**

INCLUDES ROPE!

VALVES FREEZING?
HEATED COLLARS



3"	\$212.95
4"	\$254.95
6"	\$381.95

SLUDGE HOE



\$62.50

SCRAPERS



from **\$50.00**

SPOONS

Includes Fiberglass Handle!

from **\$105**

FREE
CATALOG



SHOP ONLINE AT WWW.VARCOPUMPER.COM

OPEN LATE NITES AND WEEKENDS!

TOLL
FREE

866-872-1224

SOURCE KEY
12P8



Closing the Books

December is a good time to get a handle on the year's expenses and income, and to make decisions that can affect your tax liability

By Erik Gunn

It's that time of year again — for holiday shopping and festivities, yes, but also for the annual ritual of every smart business owner: Closing the books. Yes, it can feel like drudgery, enough to make you put it off and go watch a football game instead.

But if you want to stay on top of your business and make the most of the time you put in every day serving your customers, this is one of those essential tasks. Here's how you can make the job easier.

SEPARATE ACCOUNTS

Perhaps the most important reason to close your books at year-end is also the worst reason: to keep your personal and business expenses straight. Believe it or not, many small business owners still try to run the business out of their personal bank account, or mix personal and business expenses on the same credit card. That is a terrible idea, and owners who do it should stop right away and establish separate accounts.

"It's very important to make sure you do not commingle personal transactions with business transactions," says Brian Jenke, a certified public accountant at Sanford, Baumeister and Frazier in Fort Worth, Texas. Keep a separate bank account and a separate credit card for business use only, and keep business expenses out of your personal bank account and off your personal credit card.

Until you take that step, an annual book-closing exercise is critical to making sure you accurately track all your expenses and all your income. Now let's assume you already do those things. Let's also assume you have an outside accountant who works with you, especially at tax time, because if you don't, you really should get one.

Even in this situation, you're not off the hook: Closing the books is still important. And the more you do yourself to organize your records, the less you'll have to pay in accounting fees. "Clients have a choice," notes Jenke. "They can do it themselves, or pay us our standard billing rate."

REVIEW EXPENSES

Step 1 is to review all expenses. With separate accounts, these should be easy to capture. But you have a bigger opportunity here. Look for trends and habits that could affect the ongoing operation of your business.

Are you spending more on certain supplies (fuel, for instance)? Are you spending too much stocking up on inventory that then sits around unused? Are you making the most of seasonal price fluctuations for certain purchases?

One expense that many small businesses fail to capture, Jenke says, are refundable deposits they pay out, such as damage deposits on leased equipment. Business owners may assume it's an expense, ignoring the fact that they're supposed to get it paid back when the leased item is returned in good condition.

"A lot of times, these deposits are never requested back, because the business owners never put it on their balance sheet," Jenke says.

"If you close your books and review them every month, it's a more manageable task. Plus you get used to them and it no longer frightens you. Slow and steady wins the game."

Brian Jenke

Erik Gunn operates Great Lakes Editorial Services, consulting for businesses, non-profits, and individuals. Readers may direct inquiries to him by contacting this publication at 800/257-7222 or e-mailing editor@pumper.com.



REVIEW INCOME

Step 2 is to examine income. Are all your customers paid up? Are you keeping track of those who haven't paid? Did you forget to bill anyone? (Yes, that does happen.) Are your billings keeping up with past years? Or is business slacking off? And if so, is that a warning sign that you need to take some steps to turn it around?

If you tend to have steady income and expenses from year to year, this may be a routine task, but don't skip it. On the other hand, your income may have taken a big leap this year. That makes this year-end review particularly important. "You want to make sure you do a good year-end close," Jenke says. "Track that you've generated all of your bills properly and collected all of them, or know which ones are not collected."

PLAN FOR TAX TIME

Step 3 is to analyze the tax implications of the year just ending — and that's the big reason you're better off closing the books in December, rather than waiting for the new year. One decision you might have to make is how to depreciate big-ticket capital expenses you made during the year.

Say you bought a truck for \$40,000. Normal IRS rules require you, instead of deducting that expense all from this year's income, to spread the expense over several years according to an established depreciation schedule set by Uncle Sam.

But what if you had a particularly huge income boost in the same year? It will be better for your tax bill if you can take the entire deduction in the current year. If you've made a profit rather than lost money, that's also perfectly legal, if you follow the IRS rules for doing so.

Here's where your accountant can really help you, and you'll get much better help if you make that appointment now instead of waiting until the new year. "A CPA has more time to consult with clients in November and December," says Jenke. "Once January comes around, we're closing people's books, we're doing people's income taxes. We have a clearer focus in December to help them out."

That timing also gives you the opportunity to make decisions that could cut your tax bill. For instance, if you've had a banner year, you can move some big expenses you would pay for anyway into the current year. After Jan. 1, it's too late.

KEEP IT GOING

But if you really want to get the most out of this task, don't stop now. Put yourself on a schedule to close your books not just once a year, but every month. That's the real secret to a smooth business operation. Jenke compares it to lawn care.

"It's not that hard to cut your grass every week," he says. "What if you waited three months before you cut it? Think about how big it is, all the weeds that are in it, all the extra trimming that has to be done. You'll keep putting it off because the mountain's too big to climb. But if you cut your grass every week, it always is manageable."

Accounting is the same, he concludes. "If you close your books and review them every month, it's a more manageable task. Plus you get used to them and it no longer frightens you. Slow and steady wins the game." ■



49 YEARS OF DEPENDABILITY

TUFF-JON



- One-Piece Construction
- Lightweight
- Rust-Free Hardware
- Wood and Poly Skids
- Large Variety of Colors



60 Gallon Rinse Tank



Tuff-Jon



Tuff-Jon III



90 Gallon Free-Standing Sink



Tanks in 60, 105, 225, 300 and 440 Gallon Sizes

— OPTIONAL ACCESSORIES —



7-1/2 Gallon Handwasher



Tuff-Jon with Lifting Bracket Assembly



Sky Heater



Sinks available for the Tuff-Jon III

The TSF Company Inc. | 2930 S St. Phillips Rd. | Evansville, IN 47712

Toll Free: **1-800-843-9286** | **812-985-2630** | Fax: **812-985-3671**

E-mail: **tsftuffjon@sbcglobal.net** | Web Site: **www.tuff-jon.com**



PORTABLE TOILETS / HOLDING TANKS / HAND WASH UNITS / ACCESSORIES

Experience Matters.

LMT's Online Tank Size Wizard...

We're the custom tank authority and now we've put our tank building expertise into a tool that you can use. The **LMT Tank Size Wizard** will help you determine the tank dimensions and capacity you require.

Design your tank online and let LMT build exactly what you need.

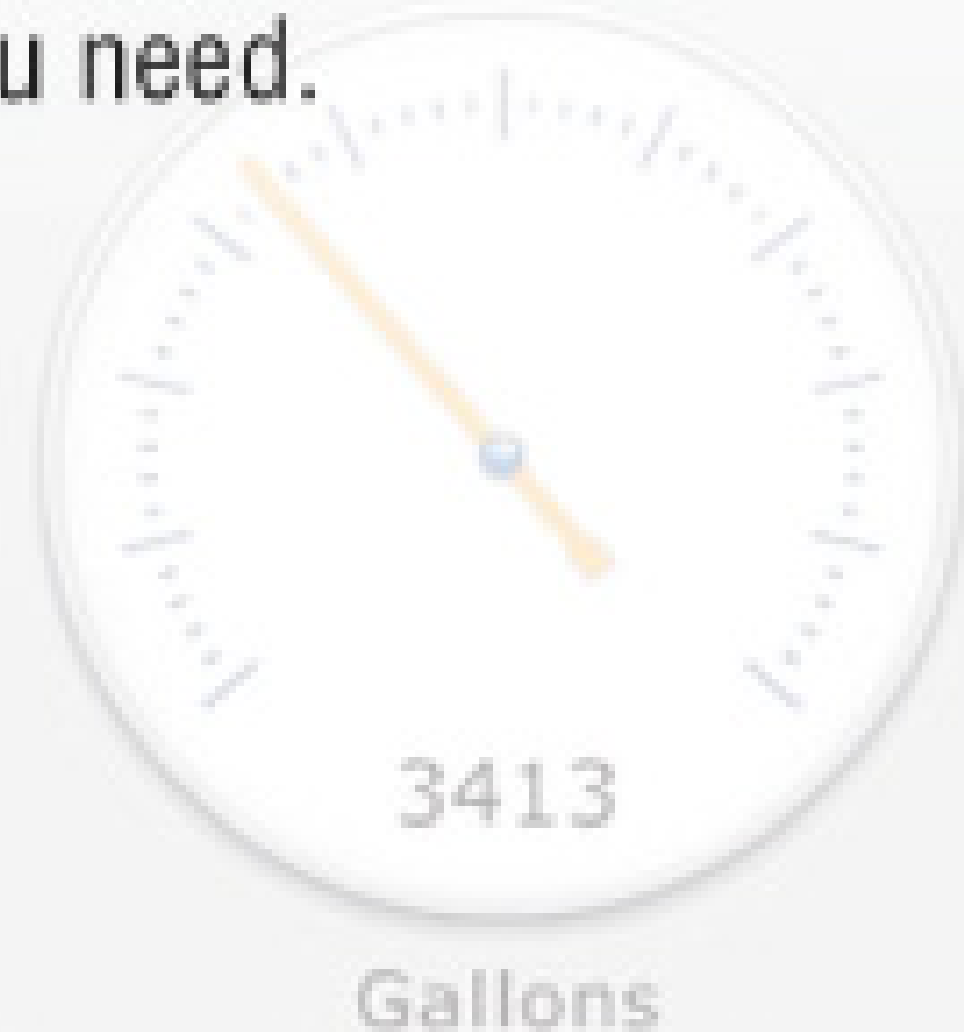

Try it for yourself at

www.tanksandpumps.com



LMT Inc. - Your Custom Tank Design Resource

Tel: 309.932.3311 • Toll Free: 800.545.0174

Fax: 309.932.3155 • info@tanksandpumps.com

Irrigation fittings are for irrigating – NOT vacuum.

How many dollars are you spending

SUCKING AIR?

Industry-proven, quality vacuum couplings from Bandlock will put money into your pockets.

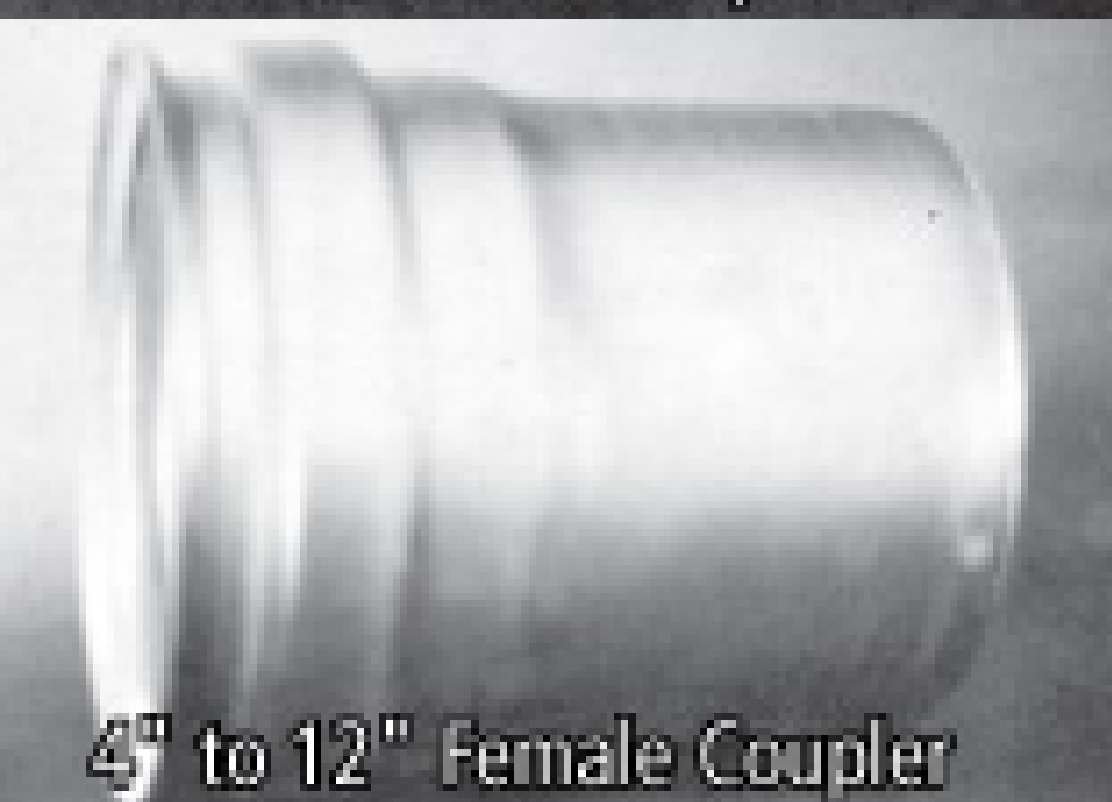

Recognized
as the
#1
Relief Valve
in the
World

CLOSE TOLERANCE
COUPLERS AND
FITTINGS BRING
"SAFETY" TO
YOUR WORK
PLACE.

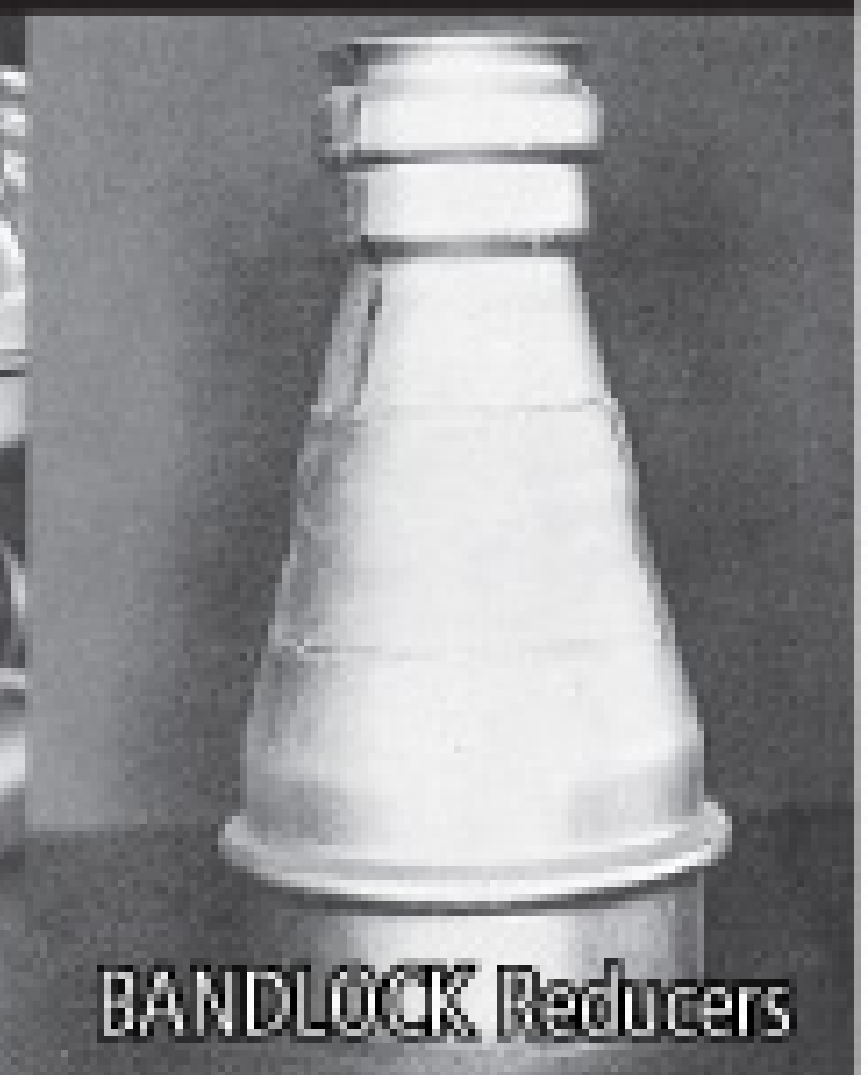
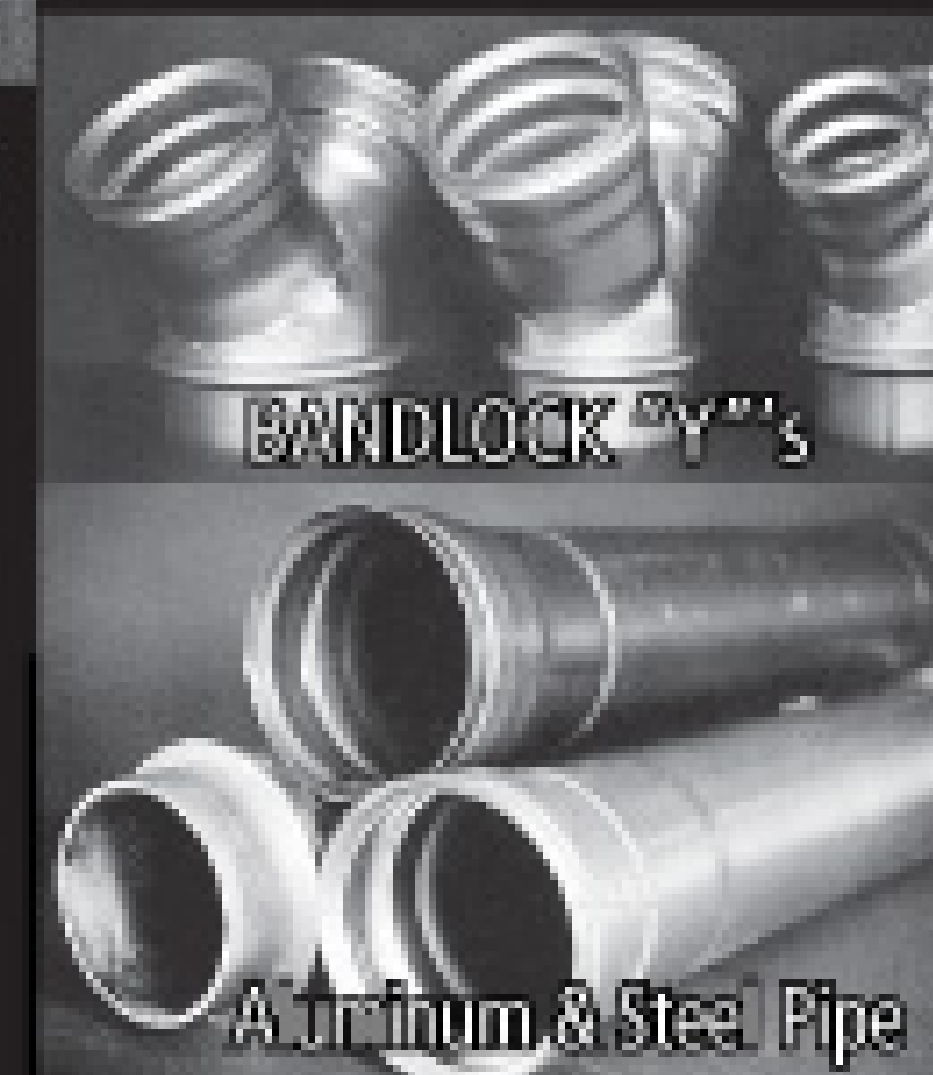

BANDLOCK
Corp.

MADE IN THE U.S.A.

Call or fax today to
get your catalog!

1-800-659-2978

Fax: 909-930-2551

www.amesbury.com

SUPERIOR "QUICK" CONNECT VACUUM AND PRESSURE COUPLINGS AND ACCESSORIES

TEAR... SQUEEZE... ODOR'S GONE!

New!

Turbo Tubes make quick work of toilet tank odor.

What could be easier? Or more powerful? The concentrated power of Turbo Tubes handles the toughest odor in seconds. Now available in three strengths for use in all seasons and conditions. New Turbo Tubes make your job easier.

- ✓ **EASY to use:** Simply tear off the top and squeeze into the tank
- ✓ **EASY to deliver:** Moisture Guard package protects against accidental activation
- ✓ **EASY to ship:** Small, lightweight packages mean less freight charges
- ✓ **EASY to control:** Proportioned quantities insure proper use and less waste
- ✓ **EASY to buy:** Turbo Tubes cost less than other portioned-controlled products
- ✓ **EASY to store:** Turbo Tubes have a long shelf life and are simple to inventory
- ✓ **EASY to handle:** No bulky containers to handle, or bottles to fill
- ✓ **SAFE to use:** Turbo Tubes are people-friendly and earth-friendly. No carcinogens.

Green Way Products are always safe - always reliable - in all seasons, all the time.

**FREE
SAMPLE
PACK**

Try them for yourself. See how Turbo Tubes make your job easier. Simply call Cindy (or your area manager) for a free sample pack.

800-241-7951



POLYPORTABLES

Listening. Learning. Delivering. Since 1972

99 Crafton Drive, Dahlonega, GA 30533 USA
Phone (800) 241-7951 or (706) 864-3776 • Fax (706) 864-8111
www.polyportables.com



TOILET DEODORIZERS • TOILET CLEANERS • AIR FRESHENERS • INSECT REPELLANT

All Green Way deodorizers, cleaners and air fresheners are earth-friendly, people-friendly products. They are developed and manufactured in our facilities in Dahlonega, Georgia by Green Way Products, a PolyPortables sister company.

Patent Pending



Louisville '09
YOUR PLACE. YOUR TIME.

EDUCATION DAY

Wednesday
February 25th, 2009

- Full day of seminars
- Exhibit hall closed
- Schedule subject to change

ROOM C201 & C202

LRN Leaders Resource Network

- 8:00 - 9:00 How to Become a Value Leader
- 9:30 - 10:30 Credit Collections: Getting Paid
- 11:00 - 12:00 The Value of Internet Marketing
- 12:00 - 1:00 **Lunch Break**
- 1:00 - 2:00 Selling Value
- 2:30 - 3:30 How to Add Value to Every Customer You Have and Future Customers
- 4:00 - 5:00 How to Determine Your Operating Costs

ROOM C203

WJTA / PSAI / CBSA

- 8:00 - 9:00 What an Air Mover Can Do For You
- 9:30 - 10:30 The Basics of High Pressure Waterblasting
- 11:00 - 12:00 Waterjetting Applications
- 12:00 - 1:00 **Lunch Break**
- 1:00 - 3:30 Understanding Your Cost to Insure Profitability (PSAI)
- 4:00 - 5:00 Cross Bores of Gas Lines in Sewers (CBSA)

ROOM C204 & C205

SSCSC Southern Section Collection Systems Committee

- 8:00 - 9:00 Trenchless Pipe Rehabilitation
- 9:30 - 10:30 CCTV Pipeline Inspections
- 11:00 - 12:00 The Nuts and Bolts of GIS
- 12:00 - 1:00 **Lunch Break**
- 1:00 - 2:00 The Nitty-Gritty on Pipeline Cleaning
- 2:30 - 3:30 Confined Space and Protective Equipment Safety Requirements
- 4:00 - 5:00 Manhole Inspections

ROOM B101 & B102

NAWT National Association of Wastewater Transporters

- 8:00 - 9:00 What are My Disposal Resources
- 9:30 - 10:30 Treatment Processes, What is Out There?
- 11:00 - 12:00 Evaluating Costs as Part of the Decision Making Process
- 12:00 - 1:00 **Lunch Break**
- 1:00 - 2:00 Meeting Part 503 Requirements
- 2:30 - 3:30 Turn Grease Trap Waste Into Gold
- 4:00 - 5:00 Developing a Business Plan

ROOM B103 & B104

NOWRA National Onsite Wastewater Recycling Association

- 8:00 - 9:00 NOWRA Overview & Industry Trends
- 9:30 - 10:30 Soil & Site Evaluation Overview
- 11:00 - 12:00 Septic Tanks: Function, Inspection, Installation & Trouble Shooting
- 12:00 - 1:00 **Lunch Break**
- 1:00 - 2:00 Aerobic Treatment Units & Filters
- 2:30 - 3:30 Pumps & Controls
- 4:00 - 5:00 Operation & Maintenance of Systems

ROOM C101 - C104

NASSCO National Association of Sewer Service Companies

- 8:00 - 9:00 Robotics For the Future, What Does it Mean for You?
- 9:30 - 10:30 Small Diameter Epoxy Coatings
- 11:00 - 12:00 Root Control, How Does it Work and Why is it Needed?
- 12:00 - 1:00 **Lunch Break**
- 1:00 - 2:00 OSHA Regulations
- 2:30 - 3:30 Choosing the Correct Chemical Grouts
- 4:00 - 5:00 Trained Technology Inspectors

ROOM C105 - C108

NEHA National Environmental Health Association

- 8:00 - 9:00 How to Work With Regulators and Regulations
- 9:30 - 10:30 Pumps: Operation & Maintenance
- 11:00 - 12:00 Routine Maintenance Inspections
- 12:00 - 1:00 **Lunch Break**
- 1:00 - 2:00 Using the Certified Installer Credential to Help Your Business
- 2:30 - 3:30 T.B.D.
- 4:00 - 5:00 T.B.D.

ROOM C109 - C112

SCOTT HUNTER Business Track

- 8:00 - 9:00 The Art of Personal Sales
- 11:00 - 12:00 The Art of Personal Sales (Part 2)
- 12:00 - 1:00 **Lunch Break**
- 1:00 - 2:00 Yes, We Have to Work Together, but Does it Have to be So Painful?
- 4:00 - 5:00 The Art of Being Outrageously Successful!

FEBRUARY 25-28

Kentucky Exposition Center
LOUISVILLE, KENTUCKY | 09



THURSDAY

February 26th, 2009

ROOM C101-C104

Portable Toilet Track

- 8:00 - 9:00 Portable Sanitation Start Up
Hampel
- 9:30 - 10:30 Selling Portable Restrooms Services
Satellite Industries
- 11:00 - 12:00 T.B.D.

ROOM C105 - C108

Liquid Waste Track

- 8:00 - 9:00 Decentralized Wastewater Sustainability - **Aquatest**
- 9:30 - 10:30 Discover the "GREEN ERA" and capitalize on it! - **Lenzyme**
- 11:00 - 12:00 Modular Waste Water Treatment
Big Fish Environmental, LLC

ROOM B103 & B104

Municipal Track

- 8:00 - 9:00 Why Measure Sewer Flows from Private Services? - **City Meter**
- 9:30 - 10:30 Polymer Solutions for Wastewater Treatment - **Fort Bend Services**
- 11:00 - 12:00 Rotary Jets for Material Removal
StoneAge

ROOM C109 - C112

Sewer & Drain Track

- 8:00 - 9:00 Bacteria Mythbusters -
ProClean by Duracable
- 9:30 - 10:30 Solutions for Nineteenth Century Manholes - **AP/M Permaform**
- 11:00 - 12:00 Manholes & Leakage Solutions
Sealing Systems

FRIDAY

February 27th, 2009

ROOM B101 & B102

Sewer Cleaning Track

- 8:00 - 9:00 High Pressure Hose Safety & Proper Use
Spir Star
- 9:30 - 10:30 The Better Jetter, Secrets to Jetting
US Jetting
- 11:00 - 12:00 Chemical Root Control
Douglas Products

ROOM B103 & B104

Business Track

- 8:00 - 9:00 Maintenance Agreements for Commercial Accounts
Spartan Tool
- 9:30 - 10:30 First Rate Customer Service
RooterMan
- 11:00 - 12:00 Insurance and Risk Management
Heffernan Insurance

ROOM C101-C104

Miscellaneous Track

- 8:00 - 9:00 Keys to Proper Power Take-Off
Muncie Power Products
- 9:30 - 10:30 Vacuum Tank, Chassis and Pumps
Amthor International
- 11:00 - 12:00 Lateral Replacement Program
TT Technology

For detailed course information please visit
www.pumpershow.com

ON SITE
installer
CERTIFIED PROFESSIONAL

Certified Onsite Installer Course
Thursday February 26th

All Day Course - 8 a.m. - 5 p.m.
Dave Gustafson, P.E., Jim Anderson, PhD

**Redefining
a hard days work...**



**wirelessly controlling
vacuum trucks
pump trucks
water jetters
hose reels
industrial vacuums**

**814.362.6811
www.controlchief.com**

**CONTROL
CHIEF**
WIRELESS SOLUTIONS

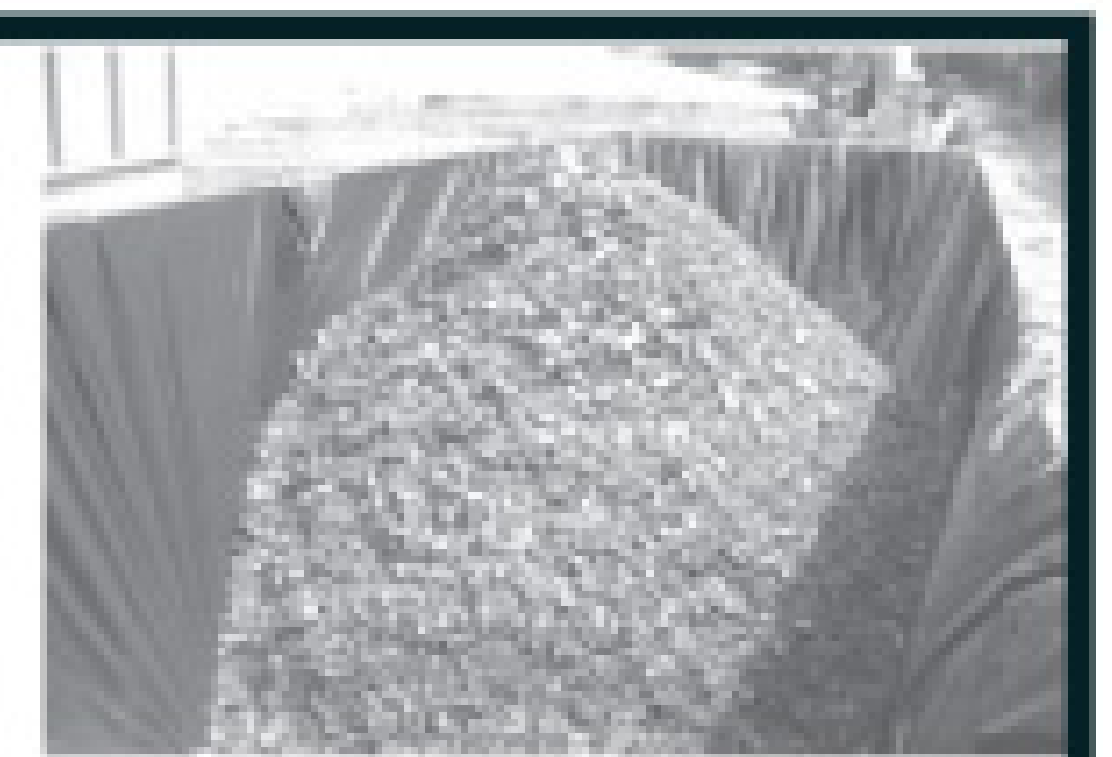
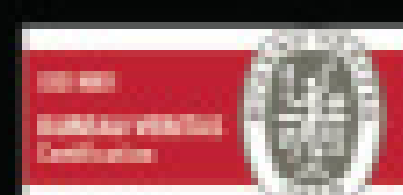

Cost of fuel & disposal dulling your bottom line?

Brighten it up with a cost savings

Belt Filter Press

From Bright Technologies

**BRIGHT
TECHNOLOGIES**

**GREASE TRAP WASTE
INDUSTRIAL WASTE
MUNICIPAL WASTE**



Booths 4194 & 4195

Made in the USA

800-253-0532 Toll Free USA
269-793-7183 Phone 269-793-4022 Fax

www.brightbeltpress.com



Patented Design

**Breathe Easier.....
Live Greener.....**

*Eco Friendly Odor Control Products For
Plumbing, Wastewater & Ventilation Systems*

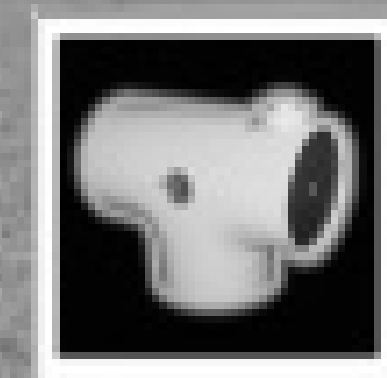
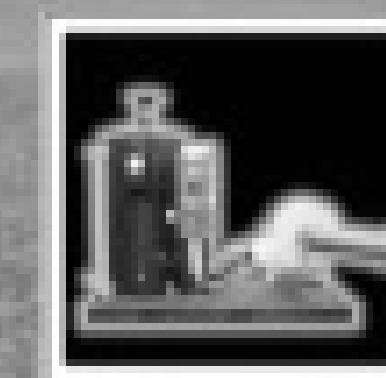
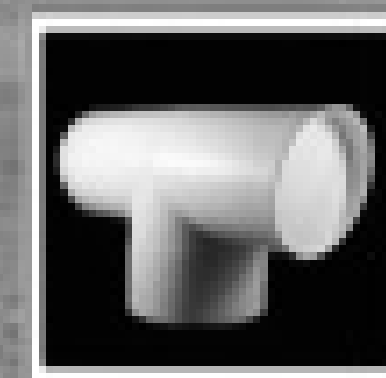

www.StopSepticOdor.com
www.IndustrialOdorControl.com

866-NO-STINK

973-846-7817



Simple Solutions
DISTRIBUTING LLC

MAKERS OF
Wolverine Brand™
ODOR CONTROL PRODUCTS



PayPal VISA MasterCard

T **RANSWAY** *SYSTEMS INC.* **PROFESSIONAL VACUUM EQUIPMENT**

Toll-Free: 800-263-4508

DELIVERY SERVICE
AVAILABLE

T: 905-578-1000

F: 905-561-9176

314 Lake Ave. North
Hamilton, Ontario L8E 3A2

WE PAY BORDER CROSSING CHARGES • LEASING? WE CAN REFER YOU TO THE SPECIALISTS • OVER 40 YEARS IN BUSINESS

HEAVY-DUTY EQUIPMENT THAT WORKS!

**LET 45 YEARS
OF EXPERIENCE
WORK FOR YOU !**



Booths 4198 & 4199



Hold on Tight

A poster wants to add another parking brake to his service rig as added insurance while stopped and pumping on a grade

This feature in Pumper reports noteworthy conversations that take place in the Pumper Online Discussion Forum for industry professionals found at www.pumper.com. The forum is split into several topic areas: General Discussion, Business, Parts & Accessories, Portable Sanitation, Pumps & Blowers, Septic System Installation, Septic System Service & Maintenance and Trucks. Simply register with a user name and password and join the discussion!

Information and advice in Overheard Online is offered in good faith by industry professionals. However, readers should consult in depth with appropriate industry sources before applying such advice to a specific business situation.

Overheard Online

HOW DO I ADD A SECOND PARKING BRAKE TO MY SERVICE VEHICLE?

Question:

I have a tandem truck with a 3,000-gallon tank and was considering adding a parking brake to the rear axle. The middle axle has a parking brake, but I would feel a lot safer with both the tandems locked when I am pumping. I have a lot of grades I park on during service. Has anybody done this? I was just wondering about the feasibility of this; it seems pretty simple to do.

Answers:

It is fairly simple, I think. You probably need either a spring brake valve and/or a relay valve, depending on the wheelbase of your truck and other factors. It is important to do it right, because the springs need to activate if there is an air-pressure loss. At its simplest, it may be just a matter of getting a four-port version of the valves controlling your front axle. But take your truck to a good shop and get someone qualified to look at it and tell you what you need.



You have two spring brakes. You need two more spring brakes and two wheel chocks. Spring brakes can only simulate 65 psi of brake pressure, not much in my opinion. Wheel chocks are a must.



Take a truck with the brakes not adjusted correctly and no wheel chocks, and in less than five seconds you could end up with the loss of a truck, \$500,000 in property damage and possible loss of life. I wouldn't want that on my mind at night. So get it fixed right or just stay on level ground all the time.



When was the last time the DOT or NHTSA (Department of

Transportation or the National Highway Traffic Safety Administration) allowed a truck like that to go down the road and how has it been passing DOT inspections since? I think spring brakes have been required on all rear axles for decades. If I am not mistaken retrofits were mandated as well. He deserves credit for recognizing the problem and trying to fix it, but shame on him if he's driving it now that he knows there's a problem. It sounds like his concern is holding on hills, but I wonder if he realizes what would happen if he blew a hose on the highway and needed those spring brakes to bring his rig to a stop. I wonder if he bought the truck that way or if an inexperienced shop installed it. He may have some recourse. I had an air axle added to a truck by an experienced shop with a good reputation and even they screwed up. They didn't realize the Japanese truck manufacturer was using antilock technology.

When the brakes were applied hard the antilock sensed traction loss and released the brakes on the main rear axle. This was causing the lift axle to do all the stopping, which resulted in skidding, smoking, wheel hop and increased stopping distance.



My 1980 truck only had emergency brake chambers on the front drive axle. It passed three Wisconsin DOT inspections by a trooper. One was in 2002. He did try to ticket me for not having straps holding down my hoses (unsecured load).



This is my second tandem truck and both of them only came with a spring brake on the middle axle and they both passed DOT inspection. One is a 1994 and one a 2000. I was even stopped at a roadside DOT spot check and didn't get a ticket or mention of needing additional spring brakes. The DOT inspections have been done at three different dealerships: Mack, International and Kenworth. I'll have to look into the requirement of spring brakes on both tandems since three dealerships and a state trooper apparently don't know what they are doing. Anyway, I had the spring brakes added to the rear axle and I feel a lot better now.

HOW DO I RID THE SEPTIC TANK OF ROOTS?

Question:

Does anyone have tips for getting rid of roots inside a septic tank or know of any products that work?

Answer:

The wisest choice for root removal in this situation would most likely be by mechanical means. Physically cutting and removing the roots. Of course the tank would be a considered a confined space, and you'd have to follow all of the necessary safety precautions.

Lastly, if roots have intruded on a septic tank, the watertight integrity of the tank has been compromised. Most likely a new tank is the answer, not killing or removing the roots. ■

ALUMINUM, STEEL and
STAINLESS TANKS manufactured,
assembled and serviced by quality
Imperial employees!



IMPERIAL
INDUSTRIES INC.
800-558-2945

**WE DIDN'T JUST INHERIT THE NAME "IMPERIAL",
WE EARNED IT WITH "IMPERIAL" QUALITY/DESIGN/SERVICE**



CUSTOM MANUFACTURED TANKS IN STEEL, ALUMINUM AND STAINLESS

- STOCK UNITS:**
- 2009 I.H./4000 Gallon Aluminum Tank
 - 2008 I.H. / 2500 Gallon Aluminum Tank
 - Ready For Delivery (Call For Details)

- STOCK TANKS:**
- 2500 Gallon Steel & Aluminum
 - 3600 Gallon Steel & Aluminum
 - 4000 Gallon Aluminum
 - All Ready To Mount On The Chassis Of Your Selection

Call Jim Stieber or Brad Rybarczyk for details!

WE HAVE UNITS AND TANKS IN-STOCK TO MEET ALL YOUR PERSONAL NEEDS!



- 2008 F550/875 Gallon Steel Service Unit
- 2008 F550/1100 Gallon Aluminum Unit
- 2008 Fuso/1100 Gallon Aluminum Unit



**In Stock &
Ready to Ship with
in 24 Hours**

- Slide-In Units in Steel/Aluminum and Stainless in various capacities!



**Happy
Holidays**



V&H AUTOMOTIVE
Marshfield, WI 54449
Randy Tischendorf

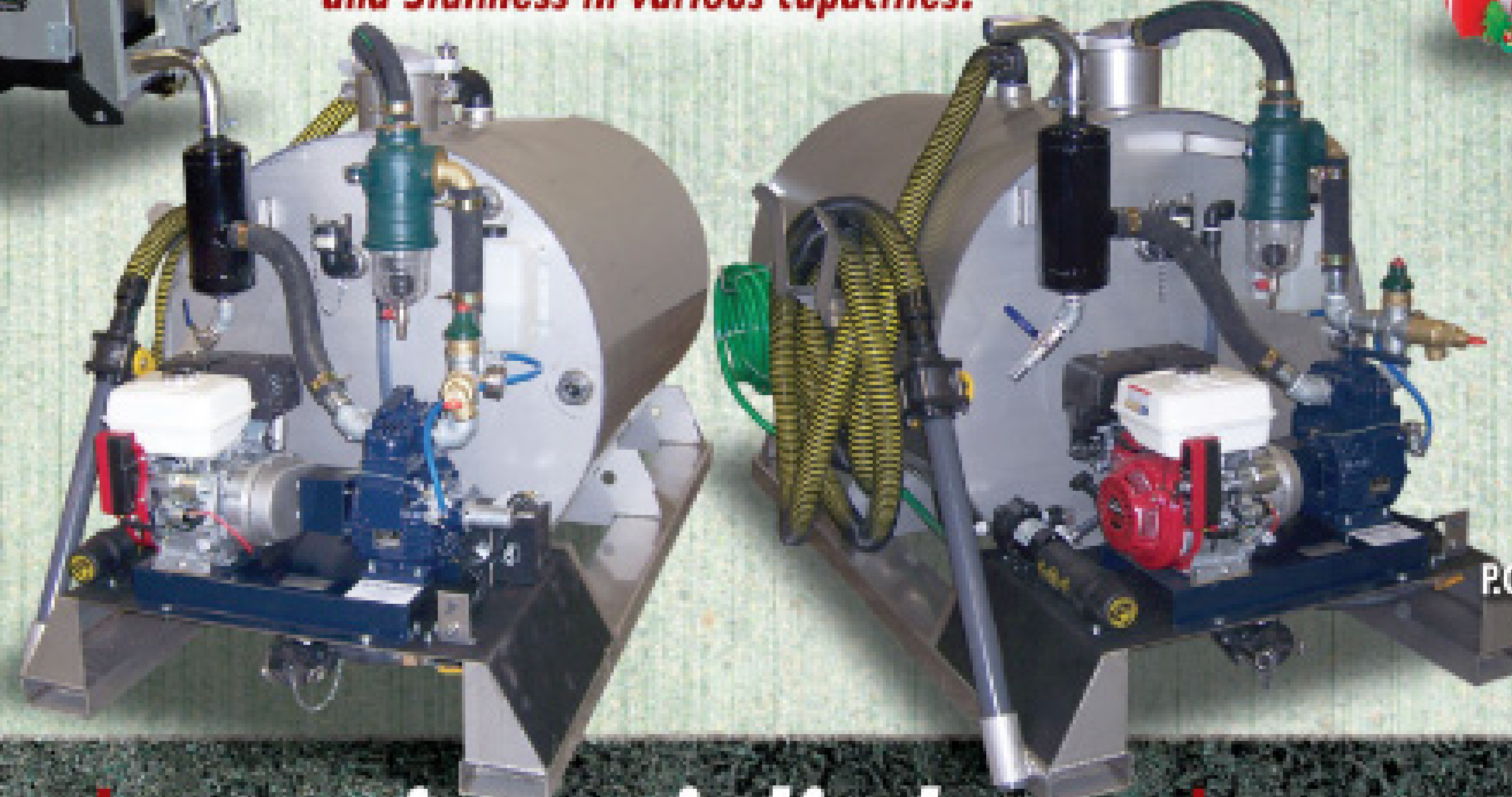

IMPERIAL
P.O. Box 1685 • Wausau, WI 54402
Tom Aerts

Hull's Truck Bodies

459 Joe Shoemaker Rd. | Minford, OH 45653

Vacuum Trucks built to order, any size or make, delivery to all 50 states. Quick turn around time.



Phone: 877.898.5104

E-mail: hullstruckbodies@yahoo.com

Webpage: hullstruckbodies.com



PAT'S PUMP + BLOWER

ORLANDO OFFICE
800-359-7867

fax: 407-648-2096

GEORGIA OFFICE

800-851-7987

fax: 404-761-7003

Now A
Factory Authorized
Dresser Roots
Sales & Service Center



#1 Pump And Blower Repair Specialist

Blower Repair Exchange Program: Roots, Spencer, Robuschi, Hicks Hargraves, Holmes

CALL FOR PRICING

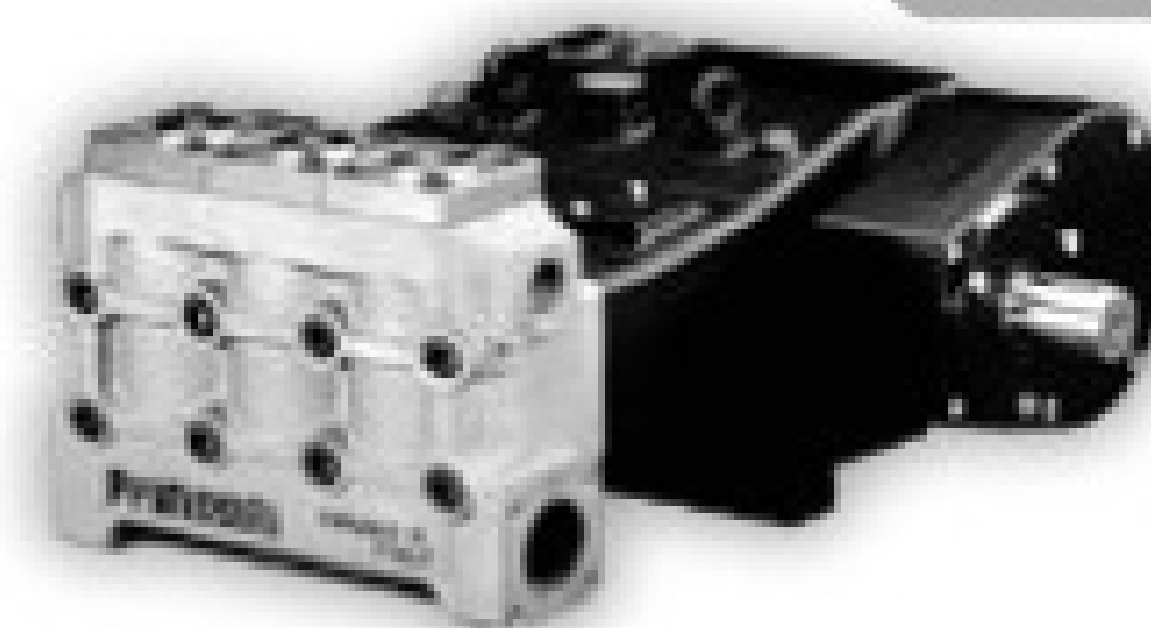

General Water Pumps

From Jet Trailers to combo units
Retrofit Kits are available!
5 year warranty

www.patspump.com

Michigan Vacuum Trucks

Custom Built Tanks to Your Specs!

P.O. Box 234 Carleton, MI 48117

Custom Built Vacuum Trucks to Meet Your Business Needs

All trucks are equipped with Masport Pumps
1/4" Steel Construction

Totaled Your Truck?

Rent a Vacuum Unit
while your truck gets fixed

2500 gallon vacuum body
ready to install on cab and
chassis \$18,000.

Specializing in
New Vacuum Trucks,
Used Vacuum Trucks,
Toilet Trailers & Slide in Units.

Purchase a New Portable Toilet
Truck for only \$45,000*

In Progress: **2003 Freightliner FL70**
with a new 2500 gallon vacuum body
400 CFM vacuum pump. **\$41,000**

Call Terry at Michigan Vacuum Trucks
734-777-0390

We Can Also Mount a Custom Designed
Vacuum Tank on Your Chassis!

Call for a **FREE** quote today!

734.777.0390

*Prices are subject to change.



Masport
NVE

SCENTBOX

The first portable toilet
made with scented plastic.

AVAILABLE FRAGRANCES:

 **Apple Blossom**

 **Pinewood Trail**

 **Rose Sensation**

 **Strawberry Field**

 **Vanilla Balm**



LEONIES

Walls do not have Armal logo.

Armal introduces the **EXCLUSIVE COUNTY PROGRAM.**

The new **EXCLUSIVE COUNTY** program gives you the ability to have **EXCLUSIVE COUNTY** rights in your state to use the **SCENTBOX** portable toilet. In order to take part in the **EXCLUSIVE COUNTY** program you need to buy just sixteen (16) toilets per county per year. Call us for additional information!

Armal Inc. 122 Hudson Industrial Drive, Griffin, GA 30224 - USA
Phone 770 491 6410 - Fax 770 491 9458 - Toll Free 866 873 7796
armal-inc@armal.biz

Armal[®]
www.armal.biz/usa

Wee Engineer
WITH IMAGINATION

Call us for a quote...



2000 GMC 6500
(under CDL) 207 HP, 6-speed manual,
302,000 miles. **New 1500-gallon tank**, carbon steel, and a **New MEC 5000 Battioni 145 CFM vacuum pump**, automatic oiler. Price**\$34,500**

Call us on this new tank.



We will find a good used truck or put it on a truck of your choice. It is a 2500-gallon, carbon steel tank.

WE



Heated Collars

Preventing your valves from freezing will help your profits during the winter months.

- 1.5-2"\$110
 - 3"\$165
 - 4"\$198
 - 6"\$297
- Installation kit and 110 volt heater kit available

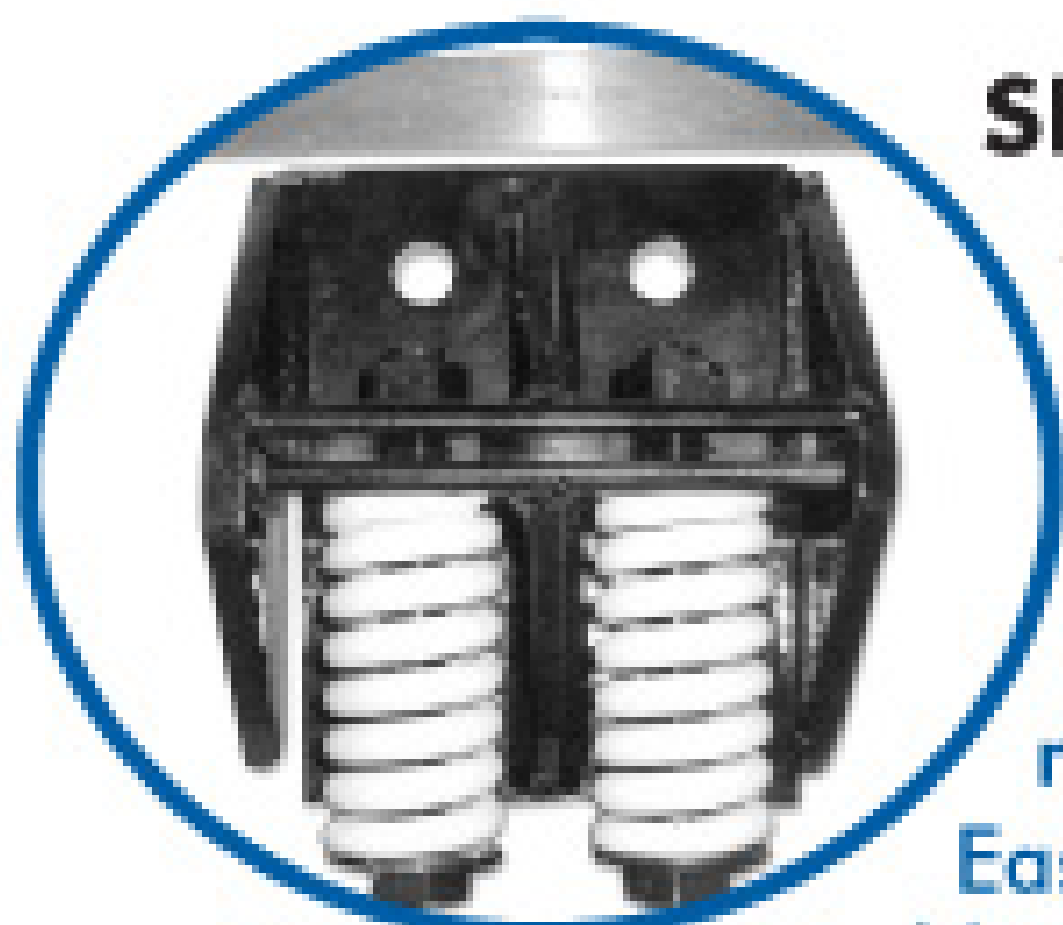

SPRING MOUNTS

decrease fatigue on your tank frame, mounts to most tanks, Easy bolt or weld on style,

Heavy-duty stress relieved springs. **Mounts with springs..\$82.00**
Springs alone\$11.00 each



Call us about this **Portable Toilet Trailer** 34-foot long, holds 18 standard units. Center fold-down T-bar accommodates handicap toilets. Includes locking toolbox, winch tiedown system, heavy-duty swivel jack. **Price: \$11,428**

P.O. Box 39 Dayton, IN 47941 Toll-Free: **877-296-2555** Phone: **765-296-2027** Fax: **765-296-3027**
www.wee-engineer.com

ARMSTRONG EQUIPMENT INC.

MODEL 806B SEELEVEL ANNIHILATOR™

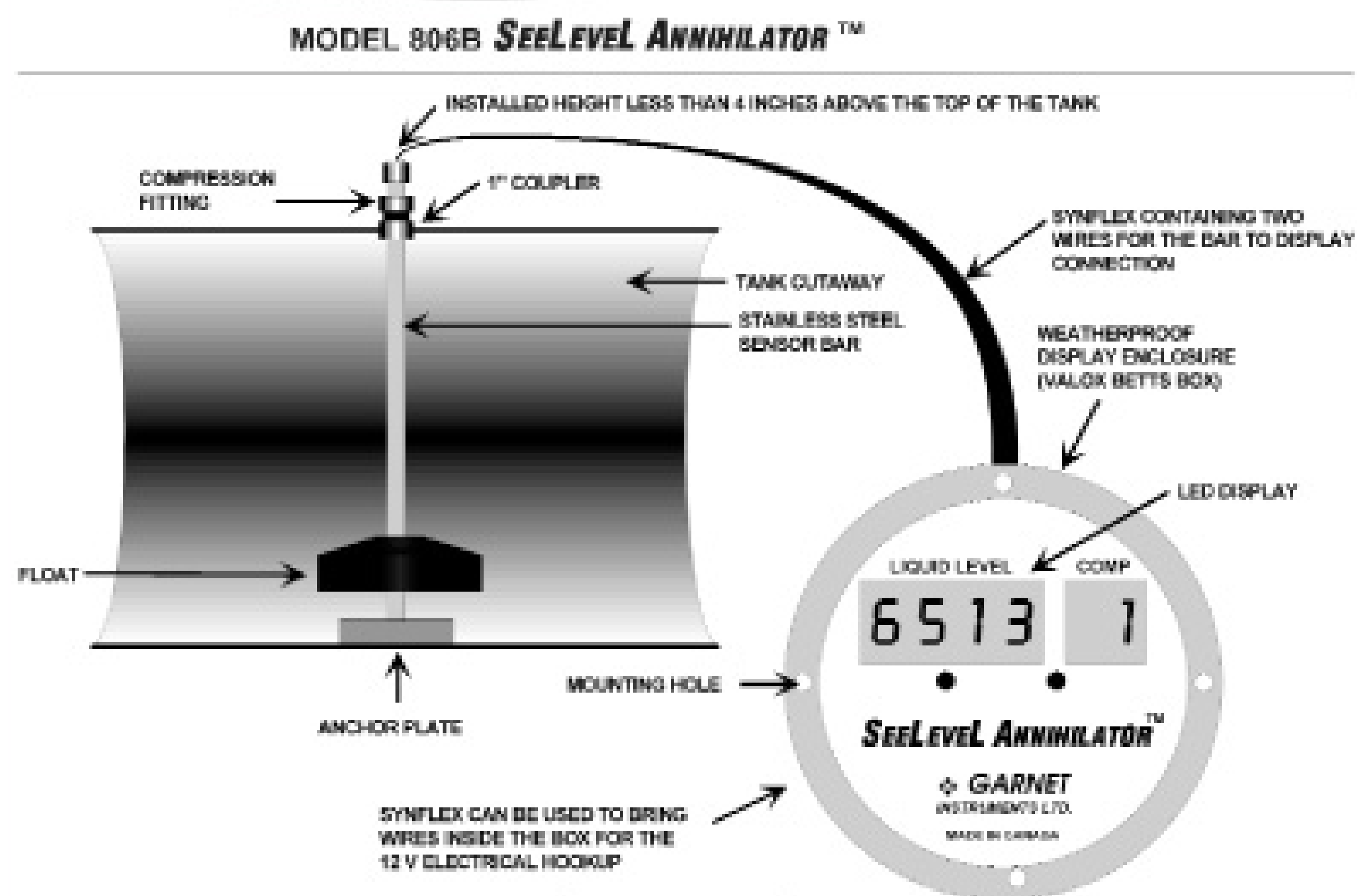

• **Accurate Readings to 1/4"**
Even with vacuum or pressure on the tank. No need to shut down pumping to check tank level.

• **Work Safely**
Can be programmed to control warning devices.

• **Plan Your Route**
Tracking customers tank size allows for improved route planning.

• **Protect Your Pump, Avoid Spills**
See the level of your tank throughout the pumping process.

• **Maximize Efficiency**
Avoid unnecessary trips. Can I get one more load, or should I head for the dump? The guessing game is over.

• **Communicate With Your Customers**
Pumping 1500 gallons from a 1000 gallon tank indicates problems

These are all good reasons to equip your next truck with a SeeLevel model 806B liquid level gauge system. The 806B can be programmed to read liquid levels in up to three compartments with only one display. It can also accept up to three alarm settings for triggering a warning light, sounding an audible alarm, or closing a loading valve; all while the tank is loading.



11200 Greenstone Ave. | Santa Fe Springs, CA 90670
800.699.7557 or 562.944.0404 | fax: 562.944.3636
e-mail: sales@vacpump.com | web: www.vacpump.com

To find out if the 806B can benefit your business, contact your tank manufacturer or call us
Toll Free at 1-800-699-7557

Experience the raw power of...

SURCO®

BLUE • MUSCLE™

THE MOST POWERFUL PORTABLE TOILET DEODORANT IN THE INDUSTRY

Stock up and Order Today!

1-800-556-0111

or on the web at:

www.surcopt.com

SURCO®

– Since 1946 –

292 Alpha Drive • Pittsburgh PA 15238

1-800-556-0111 412-252-7000

www.surcopt.com



©2008 SP

chempace[®]

corporation

www.chempace.com

Serving the Industry for Over 40 Years!

One-Stop-Solutions For PORTABLE SANITATION & SEPTIC & GREASE HAULERS

**BUYING DIRECT
ALWAYS EQUALS
COST SAVINGS**



Big Shot[®] Con2 & Con2 Plus

- Super Strength Concentrate
- Non-Formaldehyde
- Ideal for Summer Use

**NEW
FEATURES
ON 3 GREAT
PRODUCTS!**

**NEW
FORMULA!**

**ENHANCED
FRAGRANCE!**

**STRONGER
DYE**

Ultra PowrPak XL

Convenient Carry Pail
Effervescence



**SEPTIC TANK
ADDITIVES \$6** (Per Pkg)

**LONG
LASTING
PINK CUBE
\$160** (Per 4x5 lbs.)

*Designed to last in
hard to service
liftstations/grease traps*

**NEW
PACKAGING
OPTION**



SEWER FOAM \$59.75 (Per Pail)

*Reduce solids and hydrogen sulfide odors -
Economical approach to sewer maintenance.*



**BUY DIRECT CALL CHEMPACE
1-800-423-5350**

We Have Money To Loan



If you need equipment to grow
and your bank said "NO,"
call "JIM THOMAS"

We are not affected by the economy. Conserve your working capital. Keep existing credit lines intact, and enjoy the security of knowing financing is there when you need it. We offer loan and leasing plans tailored to individual needs.

- Portable Toilets
- Sewer Equipment
- Pumper Trucks
- TV Inspection
- Water Jetters
- New and Used Equipment
- Vacuum Trucks

- ◆ Programs offer longer terms for older equipment.
- ◆ We do start ups.
- ◆ 90 Day Delayed Billing.
- ◆ Seasonal Payment Programs Available

*Get Pre-Approved for the Pumper
& Cleaner Environmental Expo*

Prompt, no nonsense financing designed to meet individual requirements. Payment plans that are generally lower than other finance plans. With years of experience, we understand the competitive nature of your business. We're prepared to act quickly and decisively!

Toll-Free 877-333-4539 • www.keycommercial.com

KEY COMMERCIAL CORP.
Commercial Equipment Leasing
"Getting You The Credit You Deserve"

RouteOptix[®] Inc.

- Customer Service
- Optimized Routing
- Visual Dispatch
- Asset Management
- Disposal Tracking
- Customer Billing

Booth 3029

A Complete Software Solution

(866) 926-7849

www.routeoptix.com

info@routeoptix.com

ABERNETHY

Call Bill Abernethy at **1.800.545.0324**

Fax: 828.324.2401 • E-mail: abernethyinc@charterinternet.com

authorized distributor for:

WELDING & REPAIR INC.

Vale, North Carolina 28168



Wittig

Masport

www.abernethywelding.com

• **International • Ford • GM**

2009 PETERBILT

2500 gal. tank, 10-spd., 330 hp

2009 KENWORTH T300

2500 gal. tank, auto transmission, 260 hp

(2) 2009 INTERNATIONAL 4400

2500 gal. tank, (1) 6-spd. transmission & (1) auto transmission

NEW PORTABLE TOILET UNITS:

2008 HINO

1500 gal. portable toilet service units, auto transmission

2009 INTERNATIONAL 4300

1500 gal. portable toilet service units, auto transmission

2008 5500 CHEVROLET

1000 gal. 700 waste / 300 fresh, 2 Wheel Drive & 4 Wheel Drive available

2009 KENWORTH

1500 gal. portable toilet service unit, auto transmission

(4) 2008 PETERBILT

1500 gal. portable toilet service unit, auto transmission

WE WILL CUSTOM BUILD YOUR TANK UP TO 5000 GALLONS!

600-1500 Gallon Portable Toilet Trucks: Our Truck or Yours

SEVERAL GOOD, OLDER TRUCKS TO CHOOSE FROM:

- 2006 International - 2600 gal. tank, good condition
- 2001 International - 2500 gal. tank, good condition
- 1998 Volvo - 4000 gal. tank
- 1997 Volvo - 3500 gal. tank
- 1995 Chevrolet - 2500 gal. dump tank
- 1995 Chevrolet - 1 800 gal. tank, gas, under CDL
- 1995 International - 2500 gal. tank
- 1991 Chevrolet - 2000 gal. tank, low miles, low hours

PORTABLE TOILET UNITS:

- 2004 International 4300 Series - NEW 1100/400 gal. tank
- 2002 International - NEW 1500 gal. tank, 1100/400 tank
- 1999 Sterling - 1500 gal.
- 1997 Ford F450 - 800 gal. tank
- 1994 UD - 1200 gal. tank

MANY OTHER UNITS IN STOCK! CALL FOR UPDATE



2009 Peterbilt, auto trans, 26000 GVW, AC, 1500 gallon porta jon service unit, HXL75V Masport pump. **IMMEDIATE DELIVERY!**



Booth 7057



2009 International 4400E Series, 260 hp diesel DT 466 engine, 6-spd. trans. and world class auto, air brakes, 33,000 GVW, air conditioned, 2500 gal. tank, Masport HXL400 pump. **IMMEDIATE DELIVERY!** Also, 2500 and 3500 gal. tanks **READY FOR IMMEDIATE DELIVERY.**



2009 International 4300, 220 hp DT466, Allison auto. trans., air brakes, 25,999 GVW, air conditioned, total tank capacity: 1100 waste/400 fresh, Masport HXL75V pump. **IMMEDIATE DELIVERY!** Also, 1500 gal. tanks **READY FOR IMMEDIATE DELIVERY.**

Check with us on financing for the purchase of a new truck!

Complete Line of Masport Pumps Available



Immediate Delivery

COMPLETE PARTS AND IN-HOUSE SERVICE FOR:

AIC Vanes • Moro • Battioni • Jurop • Masport • Fruitland • NVE • Powerflo • Plus many other brands

OVERNIGHT DELIVERY ON PARTS • SAME DAY SHIPMENT ON PUMPS

WE SPECIALIZE IN PORTABLE SANITATION AND SEPTIC PUMPING EQUIPMENT

When Breaking Up is Hard to Do

Do you prefer backflushing or a mechanical agitator to eliminate a rock-solid scum layer in septic tanks?

By Mary Shafer

Every pumper has their favorite tools and techniques for certain kinds of jobs. One of the most challenging of those jobs is the tank that's been so neglected it has a veritable drumhead on it, the scum is so thick and solid. That's when you have to decide whether to backflush or to agitate. Here's what some of your colleagues tell us about their chosen method:



Name:
Tim Frank, owner
Company:
Tim Frank Septic Tank
Cleaning Co.
Location:
Huntsburg, Ohio
Employees: 11
**Years in
Business:** 42

Tim Frank relies on backflushing for the majority of small- and medium-sized tanks.

"We don't use agitators for those," he says. "Our trucks are pretty big with powerful pumps on them, so they can get the stuff out of there. But you always have

that crust that floats. What we do to get that is change the vacuum to the other side, to make pressure in the truck. Then we'll open the valve and start to 'boil' it in there hard, bring it around and mix it up.

"We'll generally pump the tank down pretty low, so as you boil the liquid against the bottom, it rolls and turns and will mix all that sludge and grease and slime up. It liquefies it."

Large tanks are a different story, Frank explains. "We don't want to spend all that time, so we do have a mechanical agitator that we'll use mainly on some of the really big tanks, the 5,000- or 10,000-gallon ones that are pretty heavy in the bottom. We've got an extension that lets us hold (the agitator) down to the bottom of the tank. When you do that, it pushes it against the bottom of the tank, and agitates it up, just like being beneath a dam.

"Then the solids just roll up and you can get it right up the hose. The bottom is where you really want to get, because there you find sand from washing clothes, and that's not doing you any good, so that's what you want to get out of there. You want to maybe leave a little bit for culture, so you wouldn't wash the sides with bleach or anything, but you really want to empty that bottom out."



Name:
Steve Lojovich, owner
Company:
Advantage Septic
& Drain
Location:
Burtrum, Minn.
Employees: 2
**Years in
Business:** 11

Steve Lojovich pumps residential systems that are located steeply downhill from where he's able to park his truck. Consequently, on jobs where he's got a stubborn scum layer, there's no way he's going to get the effluent up the hose without some seri-

ous slicing and dicing. For years he fought scum with backflushing alone, but then he heard about mechanical agitators and got curious.

Comments may be directed to Mary Shafer in care of Pumper. You may also e-mail pipelines@pumper.com.

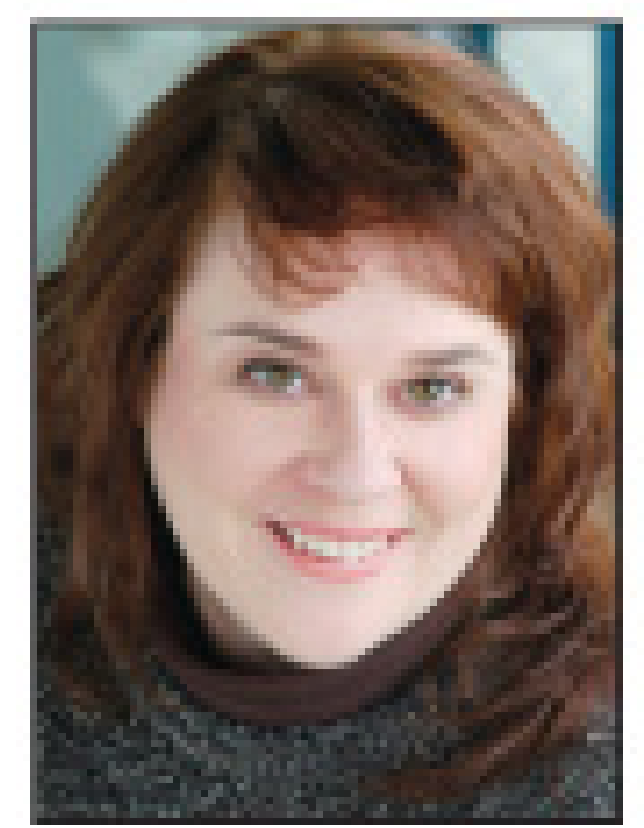

"You always have that crust that floats. What we do to get that is change the vacuum to the other side, to make pressure in the truck. Then we'll open the valve and start to 'boil' it in there hard, bring it around and mix it up."

Tim Frank

"I've used a Crust Buster since 1999," he says. "I was very skeptical that they would really work. Then I had a day off and the company that makes them is located not far from us, so I decided to go look at one. I went down there and watched them use it on an actual job. I was sold on the spot because I could see how good it worked. I bought it.

On the worst of the scum layers — he describes them as "opening up a tank and finding one you could walk on" — Lojovich still must inject water or septage from a previous job to mix a pumpable slurry. "Whenever I think I may run across one of those," he says, "I make sure it's never the first job of the day." He does this gradually — pumping in some liquid, agitating the solid layer, mixing in more liquid — until it's of a consistency that will make it up the vertical drop. But it's the agitator he credits for making short work of what used to be an endless procedure when backflushing was his only tool.



Name:
John and Judy Knelsen, owners
Company:
Chilco Creek Contracting
Location:
Vanderhoof, British Columbia, Canada
Employees: 2
Years in Business: 16

John Knelsen uses his own method of persuading stubborn scum layers to disengage and disintegrate. It's a cross between backflushing and manual agitation that works well for the systems he services.

"I take a big window scraper to break up the solid

layer, then run in some water with a garden hose," he says, making a liquid mixture he can pump out. "I've looked at mechanical agitators, but I don't think they'd work in my applications."

Judy Knelsen explains that the systems they pump are mostly residential and 50 years old or newer, and regulations require a riser that restricts access for mechanical agitators. ■

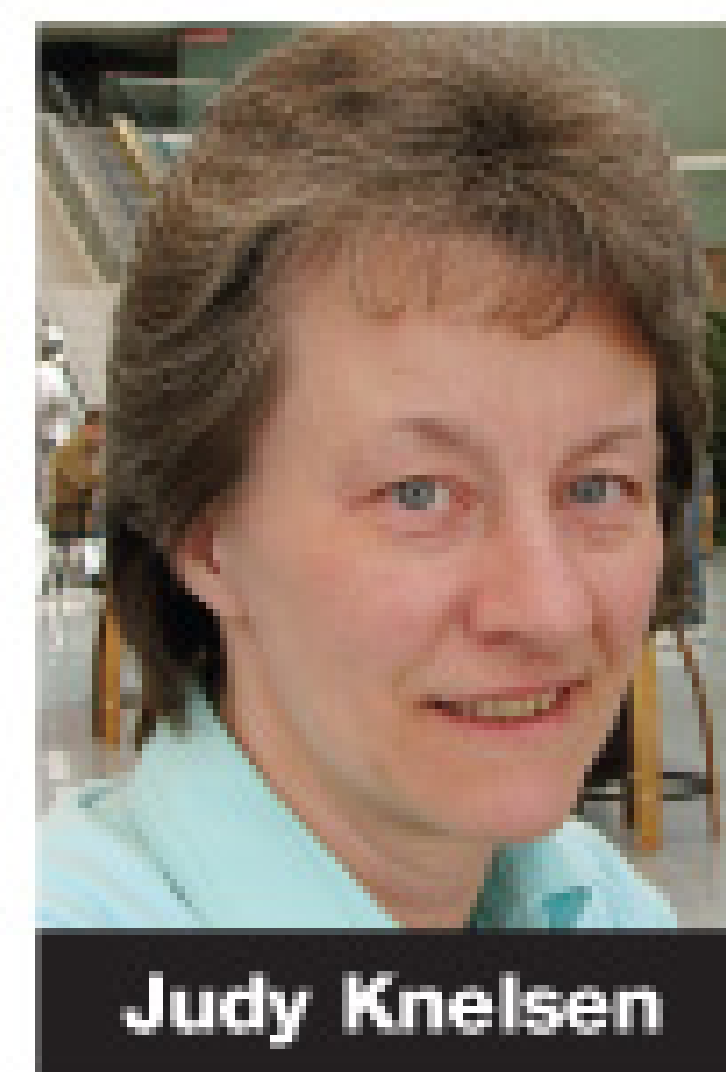

Judy Knelsen

Everyone's talking about it.

Find out why.
Get your **FREE** subscription today.

ON SITE
installer

PROMOTING WASTEWATER TREATMENT
QUALITY AND PROFESSIONAL EXCELLENCE

Visit www.onsiteinstaller.com or call 800-257-7222.



VAC-CON

PRE-OWNED EQUIPMENT

MORE POWER TO YOU



2005 VAC-CON V321LHAD

- 2005 IH 7600
- CAT C-13 380 HP / 10-SPD
- 50 @ 3000 / DEUTZ 138 HP
- Mileage: 31,000

\$195,500



1997 VAC-CON V312THAE/1300

- 1997 Ford LNT8000
- 275HP / MD3060
- 50 @ 3000 Water Pump
- Mileage: 66,703

RECONDITIONED **\$135,000**



2004 VAC-CON V390LHAD

- 2004 International 7400
- IH 275 HP / Allison MD3060
- 50 @ 3000 / DEUTZ 138 HP
- Mileage: 11,000

RECONDITIONED **\$198,500**



1998 VAC-CON VPD3612LHA

- 1999 IH 2554
- 275 HP / Allison MD3060
- 80 GPM @ 2000 PSI
- Mileage: 116,000

\$130,000



2006 VAC-CON V312LHAD

- 2007 STERLING LT7501
- CAT 275 HP / Allison 3000RDS
- 50 @ 3000 / DEUTZ 138 HP
- Mileage: 23,000

\$209,500



2000 VAC-CON VPD3609SHA

- 2001 IH 2654
- 275 HP / Allison MD3060
- 60 @ 2000 / John Deere 4045T
- Mileage: Approx 45,000

\$145,000



2001 VAC-CON V312LHAD/1300

- 2001 Sterling LT9501
- CAT 380 HP / 10-Speed
- 80 @ 2000 / Cummins 110 HP
- Mileage: 73,000

RECONDITIONED **\$185,000**

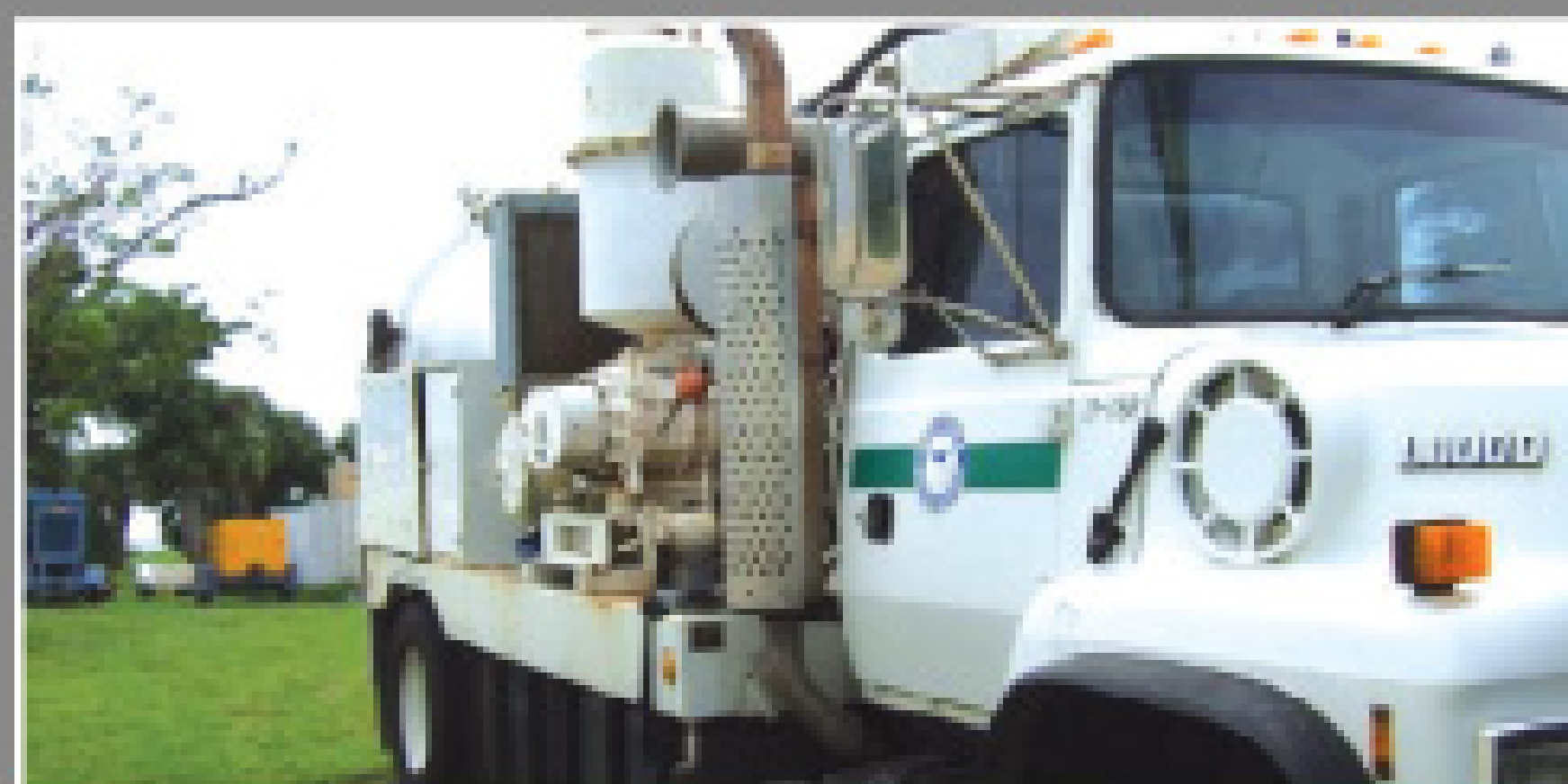

1995 VAC-CON VPD3690THA

- 1995 FORD LN8000
- Cummins 250 HP / Allison MD3060
- 30 @ 3000 / John Deere 4039T
- Mileage: 57,500

RECONDITIONED **\$95,000**



www.vac-con.com

*Ultimate
Lease*

Ultimate Lease Hotline:
888-817.1757

969 Hall Park Drive • Green Cove Springs, FL 32043 U.S.A.
Tel: 904-284-4200 • Fax: 904-284-3305
www.vac-con.com • vns@vac-con.com

1-YEAR, 100,000 MILE ENGINE WARRANTY NATIONWIDE • COMPARE OUR TRUCKS AND PRICES TO ANYONE



THANKS TO GORGE VALENZIA

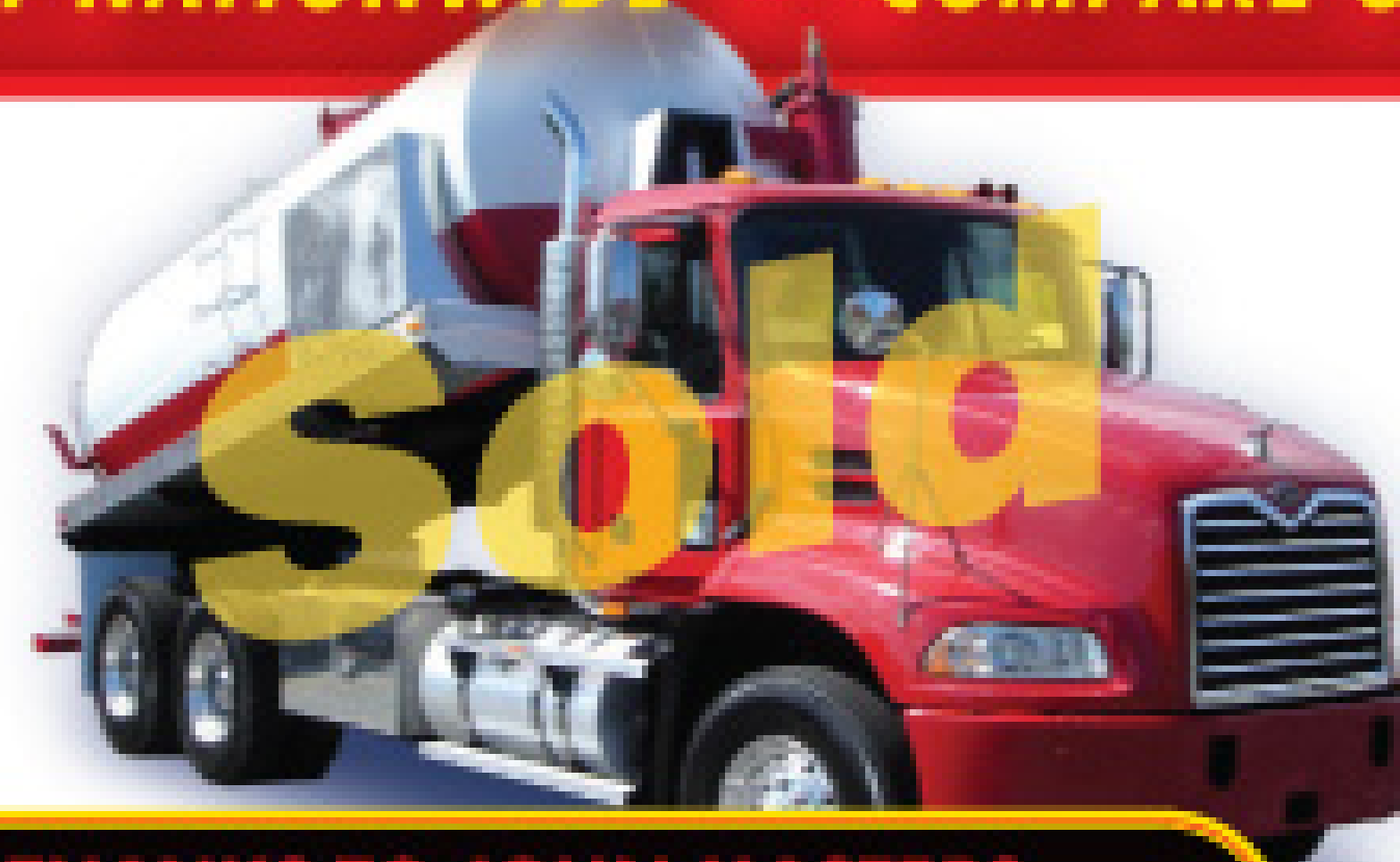

THANKS TO JOHN MASTERS,
Special Tank All hydraulic Rear Man Way And Dump



THANKS TO MARK SHAW



THANKS TO ANTHONY
Two Compartment 5000 GAL, Dual Pumps, All Remote Controls

IN STOCK & READY FOR DELIVERY

- 2000 INTERNATIONAL - 4000 Gallon DUMP
- 2000 FREIGHTLINER - 2200 Gallon
- 2005 MACK VISION - 4000 Gallon
- 2003 INTERNATIONAL - 4800 Gallon
- 2002 MACK VISION - 3800 Gallon
- 2005 MACK VISION - 3600 Gallon
- 2005 MACK VISION - 4000 Gallon



THANKS AGAIN TO ANTHONY
Custom Built 5000 Gal. Dual Compartment,
Two Vacuum Pumps All Controls Remote

OUR 28TH YEAR
NATIONAL TRUCK CENTER

9750 N.W. 27th Ave. | Miami, FL 33147 | Phone: 305.691.8407 | Fax: 305.691.8416

www.nationaltruckcenter.com

★ **WE EXPORT OR DELIVER** ★

U.S. Tanks

THE TOP DOG OF VACUUM TANKS

1000 Gallon Trailer Mounted Vacuum System



EXPERTS IN PORTABLE VACUUM SYSTEMS!

PACS 1000

PACS trailer mounted vacuum systems are available in a variety of configurations. PACS 1000 is designed for removing liquids, solids, and sludge from land or water. Costing less than vacuum trucks, the PACS is approved for highway towing. Integral hydraulics allow the PACS to run oil skimmers and pumps, as well as lift the tank to dump contents.



ELASTEC MiniVac

Oil Skimmer
Sucking up money for vacuum trucks

Our Drum Skimmers are optimal for rapid response oil cleanup. Extremely efficient and cost effective, they will give you an edge over competitors.



DrumIt

The drum filling vacuum head with auto shut off. DrumIt quickly connects to vacuum trucks for a clean interception of debris and liquids.



ELASTEC
AmericanMarine
Innovative Environmental Products

1309 West Main, Carmi IL 62821 USA
Tel: (618) 382-2525
Fax: (618) 382-3610
E-mail: elastec@elastec.com



www.elastecsales.com

PU06/08

Supplying your Business for Seasons of Success



- **One-Stop Shopping**
Our wide selection of products makes shopping at several different places for all of your needs a thing of the past.
- **Very Competitive Pricing**
- **Huge Selection**
We carry a wide selection of portable restroom parts and accessories to take care of all your needs. Including toilet parts, pumps, pressure washers, hoses, valves, fittings, tank components, chemicals, dispenser systems, hand sanitizer, deodorizers and odor control products, engines, sink parts, cleaning supplies, and much much more.
- **Two Locations for Faster, More Economical Shipping**
Our warehouses in Utah and Georgia are strategically placed to service every state.
- **Custom Pump Trucks**
If you can imagine it, we can build it. We pride ourselves on our ability to work with our customers and design an efficient and effective pump truck designed around your custom applications.



**CALL TODAY for your
FREE product catalog!**



1-888-935-1133
www.toico.com

YOUR ONE STOP SOURCE FOR PORTABLE RESTROOM PARTS AND SUPPLIES



CIRCLE D TRUCK SALES

www.circledtruck.com



IN STOCK

2005 MACK VISION CX813, AC-427 Mack 427 HP, 10 Spd OD, Engine Brake, Air Ride Suspension, 3.58 Ratio, 223" WB, Aluminum/Steel Wheels, 450,050 miles, NEW 2008 BULLDOG Vacuum Tank, 3360 Gallons (80BBL), 1/4" Head & Shell Thickness, Primary & Secondary Shutoff, (2) Top Manways, (1) Rear Clean Out (2) Internal baffles, Sump With (2) 4" Rear Outlets With Water Style Butterfly Valves, Front Sight Glass, Vacuum & Pressure Relief Valves, Full Length Hose Trays, Rear Bumper, JUROP R260 Vacuum/Pressure Pump With Pump Stand, Right Angle Drive. Stk. #2091 **\$92,500**

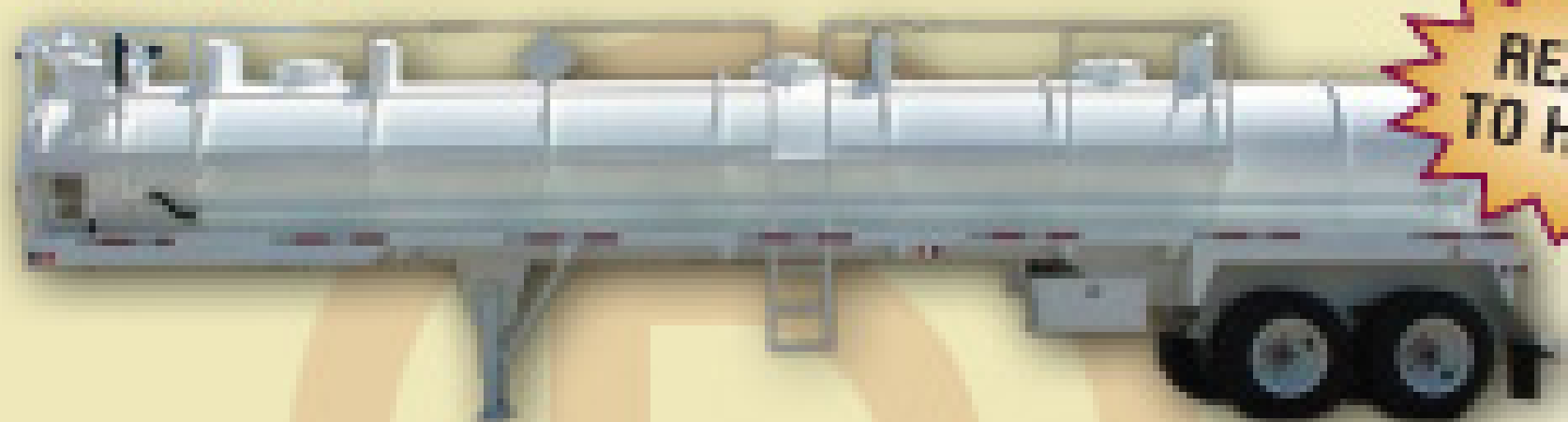

READY TO HAUL

NEW 2008 130BBL (5460GL) DOT 407/412 ASME VACUUM TRAILER, Spring suspension, 11R24.5 tires, Full length walkway with handrails, (2) 4" butterfly valves with air to open spring to close at rear, (3) 20" diameter DOT certified National Vacuum domed manways, (1) 20" diameter DOT verified National Vacuum domed manway located on lower rear head, 12" heavy duty DOT internal shut-off at top front of tank, Outside scrubber with dome lid and 2" drain, Girard 3" relief valve, Front, Center, and rear overturn protection, External arrow rotary float gauge with 8" stainless steel float ball, 18"x18"x36" toolbox with locking latch (2) work lights with on/off switch located at rear. **Call For Price**



VERY NICE!

2006 FREIGHTLINER FLD12064SDT, 186K miles (Actual miles), MBE 350 HP, Allison 4500 RDS, 40,000 lb RA, 12,000 lb FA, Air ride suspension, Engine Brake, 4:63 ratio, 202" WB, 127" CT, Dual 80 gl. Aluminum fuel tanks, Cruise, AC, PS, AM/FM stereo, Chrome exhaust, "NEW" Presvac DOT-MC MC 412, 3150 Gallon, Tilt With Full Open Rear Head, 4" Load Line With Riser, 6" Discharge, Catwalk With Handrails, Fruitland RCF 500 Vacuum Pump. Includes FET; VERY NICE!!! Stk. #2287 **\$154,750**



VERY NICE!

2008 TROXELL 130BBL, Vacuum Trailer, non-code, 4 Spring Suspension, Steel Composition, 24.5 Tires, All Steel Wheels, Tandem Axle, Steel Composition, 5460 Gallons, 1 Compartments, Full length walkway with Tool box, (2) 4" butterfly valves, scrubbers, Full length hose trays. Ready to haul!! \$1500 for Optional Belly Line. Stk. #1906. **Call For Price.**



IN STOCK

2003 MACK CH513 E7-427 HP, 10 speed, 573K miles, Mack Air ride suspension, 3:90 ratio, 40,000 lb. RA, 12,000 lb. FA, 11R22.5 tires, Chrome exhaust, Tilt/telescopic wheel, Cruise, AM/FM stereo, AC, PS, "NEW" Presvac DOT-MC MC 412, 3150 Gallon, Tilt With Full Open Rear Head, 4" Load Line With Riser, 6" Discharge, Catwalk With Handrails, Fruitland RCF 500 Vacuum Pump. VERY NICE! Stk. #2312 **\$118,500**

MORE TRUCKS AND TRAILERS AVAILABLE, IF WE DON'T HAVE IT WE'LL FIND IT!

Lee Dill, Richard Roberts, John Trammell, Gary Chandler
CIRCLE D. TRUCK SALES

4502 E. OVERLAND TRAIL • ABILENE, TX • 79601
325-677-0474 • FAX: 325-673-7207

888-433-0474

Make your own salt brine with ...

The **BRINE-MAX** System



Call now for Details!

Salt brine, the economical alternative to methanol



KentuckyTank

Plastic Tanks and Accessories

1-888-459-8265

www.kentuckytank.com

Bulk Storage & Transport Tanks



Ask for an Extra Discount on bulk storage & transport tanks now until **December 31ST**

LOW PROFILE Portable Holding Tank

100 • 210 • 300 Gallon Sizes

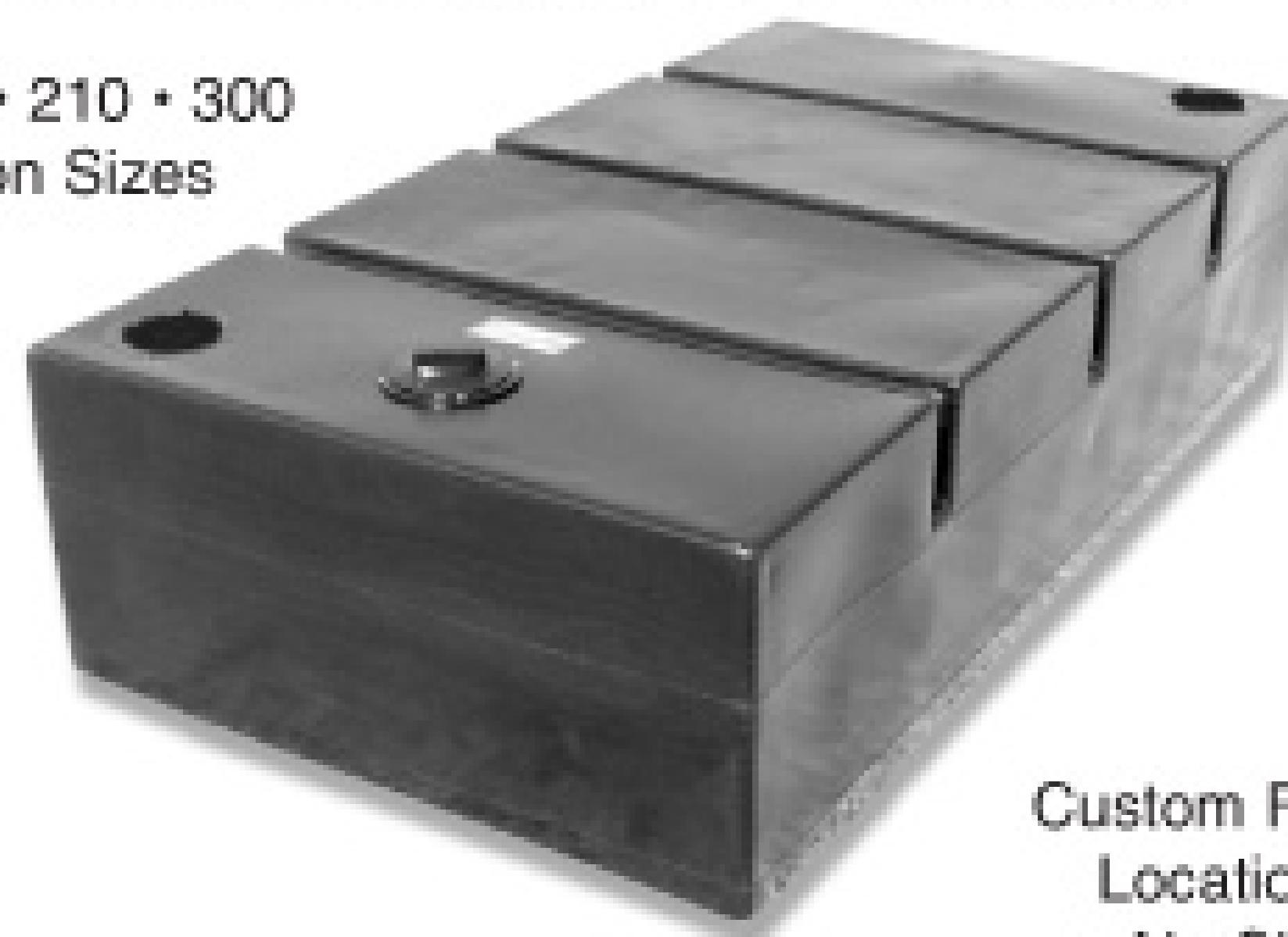

Custom Fitting Locations at No Charge



1250 Gallon Size

Mega Holding Tank



On-Site Water System

65 Gallon self-contained

NORWESCO

Distributor Since 1987

Nationwide Shipping Points

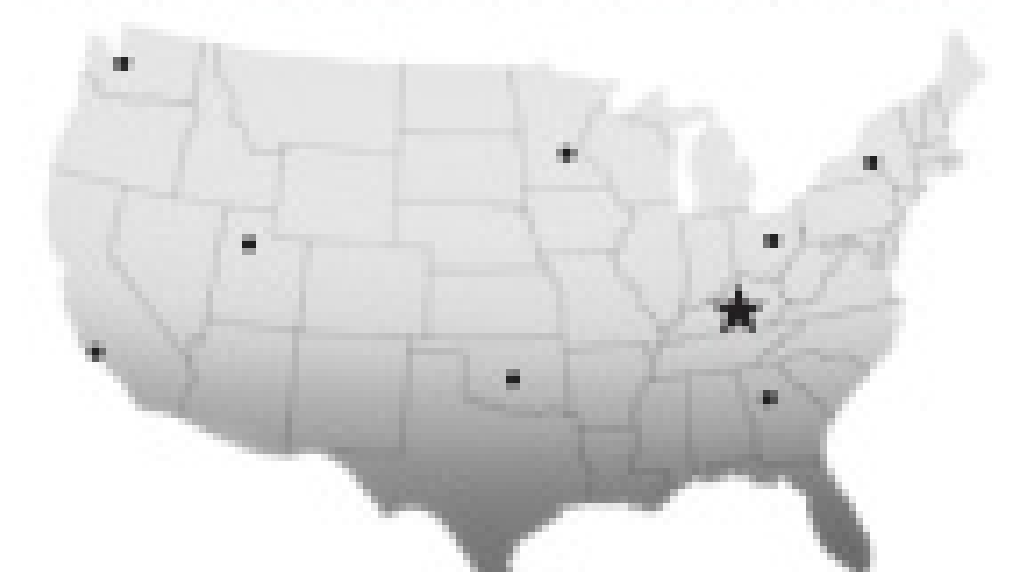

JOIN THE TEAM

Team

NVE

National Vacuum Equipment

800-253-5500

www.nvepump.com

Challenger™ Packages

- Industry Leading Design and Fabrication
- Dependable High Performance Vacuum Pumps
- Complete, Easy to install
- Reduce your Engineering and Installation Time
- Increase Profits

367 and 506 Muffler Pack

Includes: Fan or Liquid Cooled Vacuum Pump, Powder Coated Pump Stand, Gearbox, Pump Coupling, and Oil Catch Muffler

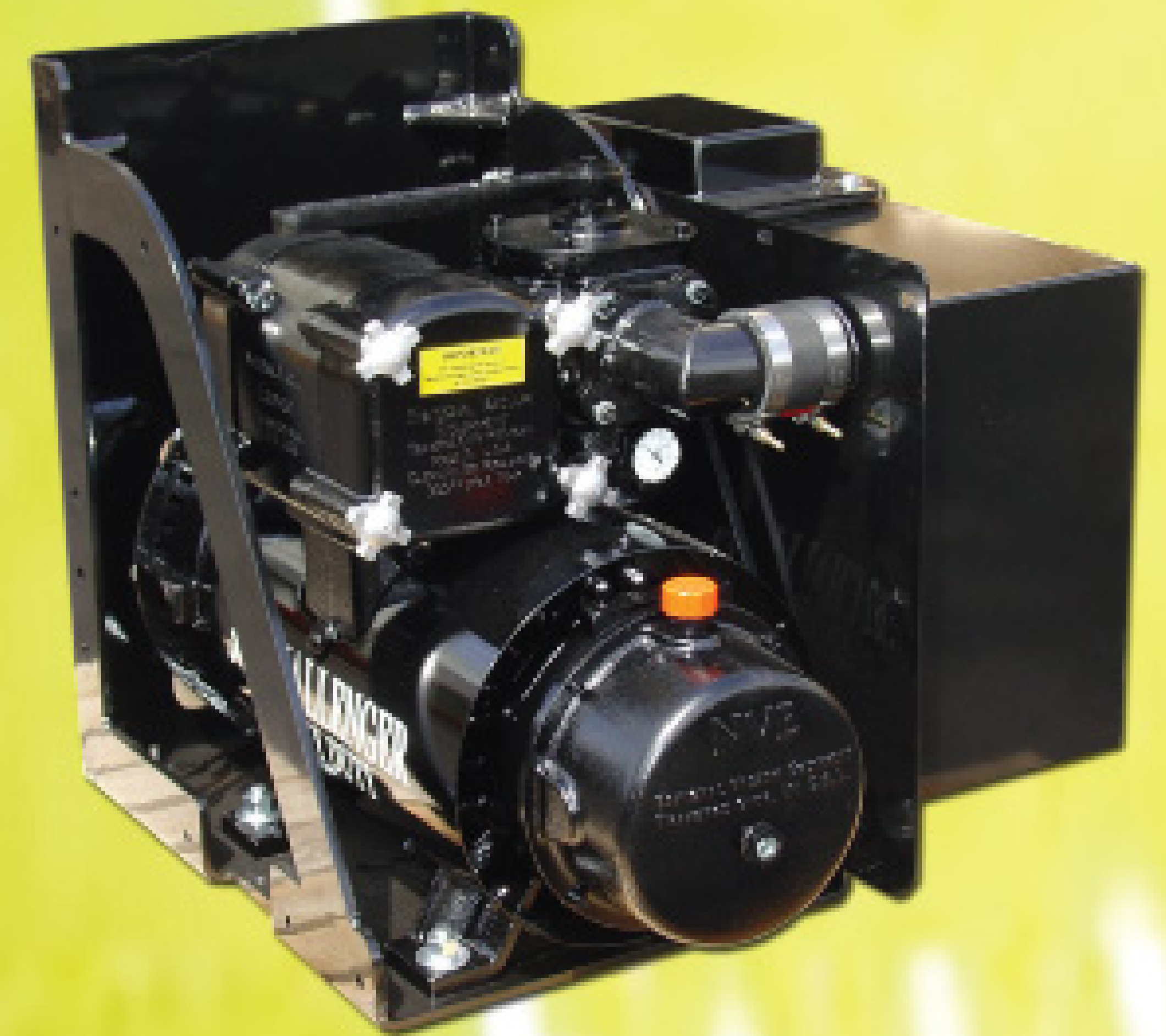

367 and 506 Max Pack

Includes: Fan or Liquid Cooled Vacuum Pump, Powder Coated Pump Stand, Gearbox, Pump Coupling, Secondary Shutoff, Oil Catch Muffler, Vacuum & Pressure Relief, and Vacuum Pressure Gauge

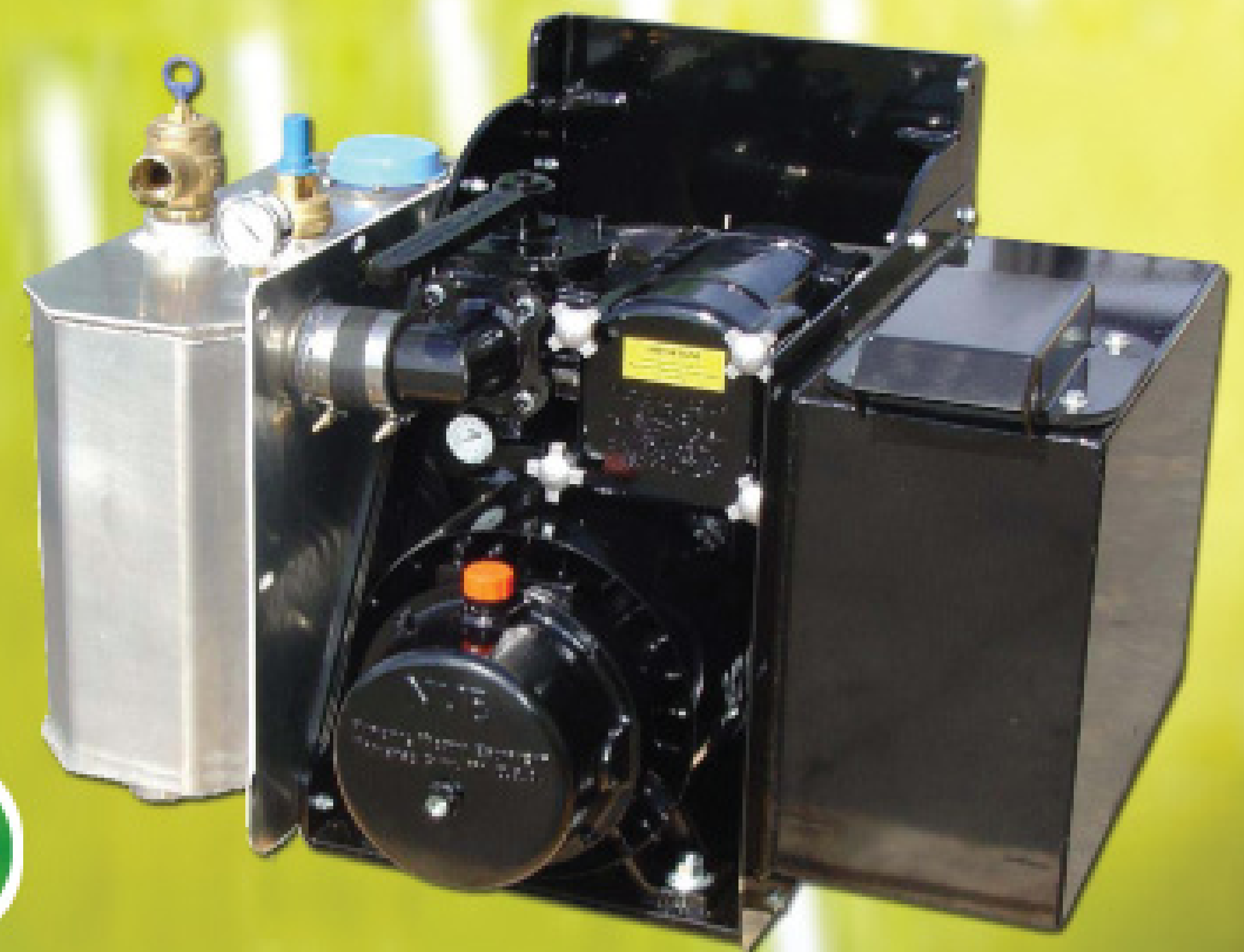

Booth 8149

Join the most Powerful Team

with the Best Performance Products!

Tanks built
for work and
built to last.



Amthor is Built Strong

Looking for a new tank? Think Amthor.

At Amthor, we deserve our reputation for quality, innovation and expertise. Our products meet the demands of today's consumer AND exceed industry expectations. With a nationwide distribution network, delivery is simplified. Plus, you'll enjoy exceptional customer service. Visit us online for specific product information.



Amthor Matador
Run-About



www.AmthorInternational.com

For your nearest distributor contact: Hank Vanderveen

VA Office: 434.656.6233 • Tel/Fax: 252.293.1284 • Cell: 845.494.0104



**We Build Trucks
That Suck!**

VSI Vacuum Sales Inc.

51 Stone Rd. | Lindenwold, NJ 08021

888-VAC-UNIT | 888-822-8648 | Fax: 856-627-3044
E-mail: vsisales@aol.com | www.VacuumSalesInc.com

NEW EQUIPMENT CUSTOM BUILT TO YOUR SPECIFICATIONS



(13337 A, B, C & D) **2009 Peterbilt 340** with a Presvac 3,600 gallons (US), aluminum vacuum tank unit. **In Production!!**



(13325V) **NEW Presvac** 5,500 gallon C/S, DOT Certified, Vacuum tank unit, self contained. **In Stock.**



(13340V) **2009 Peterbilt 365** triaxle with a New Presvac, Powervac 3800, 3,250 gallon (US), DOT, wet/dry industrial, vacuum tank loader. **In Stock.**



(3680V) **2003 Mack CV713** cab and chassis with a 3,200 gallon, s/s vacuum-pressure tank. Masport pump package. **Coming Soon!!**



(4506V) **1994 International 4700** with a Keith Huber 1,500 carbon steel portable Toilet service unit.



(13335 B & C) **2009 Peterbilt 340** with a Presvac 3,200 gallon, c/s DOT certified 407/412 Dump type vacuum tanker with a full open rear. **In Production!!**



(13336) **2009 Sterling LT9500** triaxle with a new Presvac, Powervac 3800, 3,250 gallon (US), DOT, wet/dry industrial, vacuum tank loader.



(13317V) **New PipeHunter Model 38T44 Jetting unit** Trailer mounted unit, w/ 335 Poly water tank 4,000 psi @ 25 gpm, 600 ft of hose and attachments.



(4358V) **New 2007 Isuzu NQR** with a 1,250 gallon, aluminum portable Toilet service unit.



(6499V) **1995 International 4700** with a Keith Huber 1,500 carbon steel portable Toilet service unit.

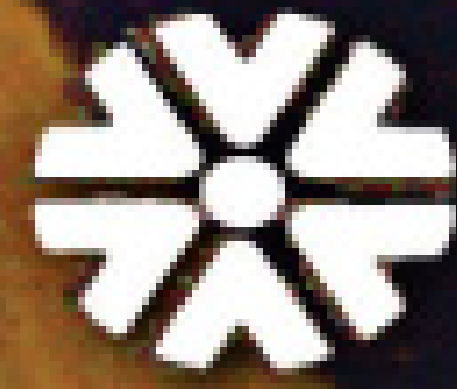

CENTER CAPITAL CORPORATION®

A Webster Bank Company*

Financing geared toward your business success.

THE INTELLIGENT CHOICE

FOR INNOVATIVE FINANCING SOLUTIONS

Environmental Equipment Financing Division Financing Geared To Your Business Success! The Intelligent Choice For Innovative Financing Solutions

Center Capital's Environmental Equipment Financing Division offers equipment leasing and financing services tailored to the unique requirements of the waste management and environmental industries. Unlike traditional lenders, our sales team has expertise in both financing and waste management. We understand the kind of payment plans that make sense for your industry. We understand the equipment. We understand the day-to-day business issues you face.

When you work with Center Capital, you're partnering with professionals who understand your business and what it takes to help it grow.



Merry Christmas & Happy New Year from all of us at Center Capital! Thanks for all your business!

PAYMENT PROGRAMS

STRUCTURED TO FIT YOUR NEEDS

SUBJECT TO CREDIT APPROVAL

APPLICATION PROCESS

SIMPLIFIED

VENDOR VALUE-ADDED

PROGRAMS

MORE INFORMATION

CONTACT

Robert A. Marino
Sr. Vice President



Booth 186

Phone: 800-344-2224 • Fax: 215-542-1307
Website: www.centercapitalcorp.com

*Center Capital Corporation is a subsidiary of Webster Bank, N.A., Member FDIC

A Jobsite Tool with Real Impact

A longtime Minnesota pumper shares the design he favors for impact probes and manhole covers

By Roger E. Machmeier, Ph.D.

When pondering the “tools of the trade” editorial theme for this issue of *Pumper*, I’m reminded of my friend, Larry Fyle, of Nisswa, Minn., and his expertise at septic tank location and making the service routine more convenient for future visits to a residential onsite system.

Though Fyle is retired from pumping, and his service business continues with his son, Tony, he has some solid advice about making pump-outs go quickly and easily. While many of you utilize the same tools and techniques, a quick review might help technicians who are newer to the pumping business.

Fyle and many other sewage system evaluators in Minnesota carry an impact probe — sometimes custom-built — on their service trucks. Fyle showed me the probe he uses to find tanks, sewer pipes, distribution boxes, drop boxes, and underground trenches and beds.

Some probes use a T-handle and the probe has to be physically pushed into the ground. The impact probe is simply “hammered” into the ground until an object is detected. The impact probe is constructed so the probe rod can be “hammered” out of the ground as well.

Fyle demonstrated the probe for me. When the probe hits a concrete object like a septic tank, there is a distinct sound and feeling on the probe. A 4-inch plastic sewer pipe also has a distinct “feel.” It is a little “softer” than a concrete object.

The impact probe will also locate the rock layer in trenches

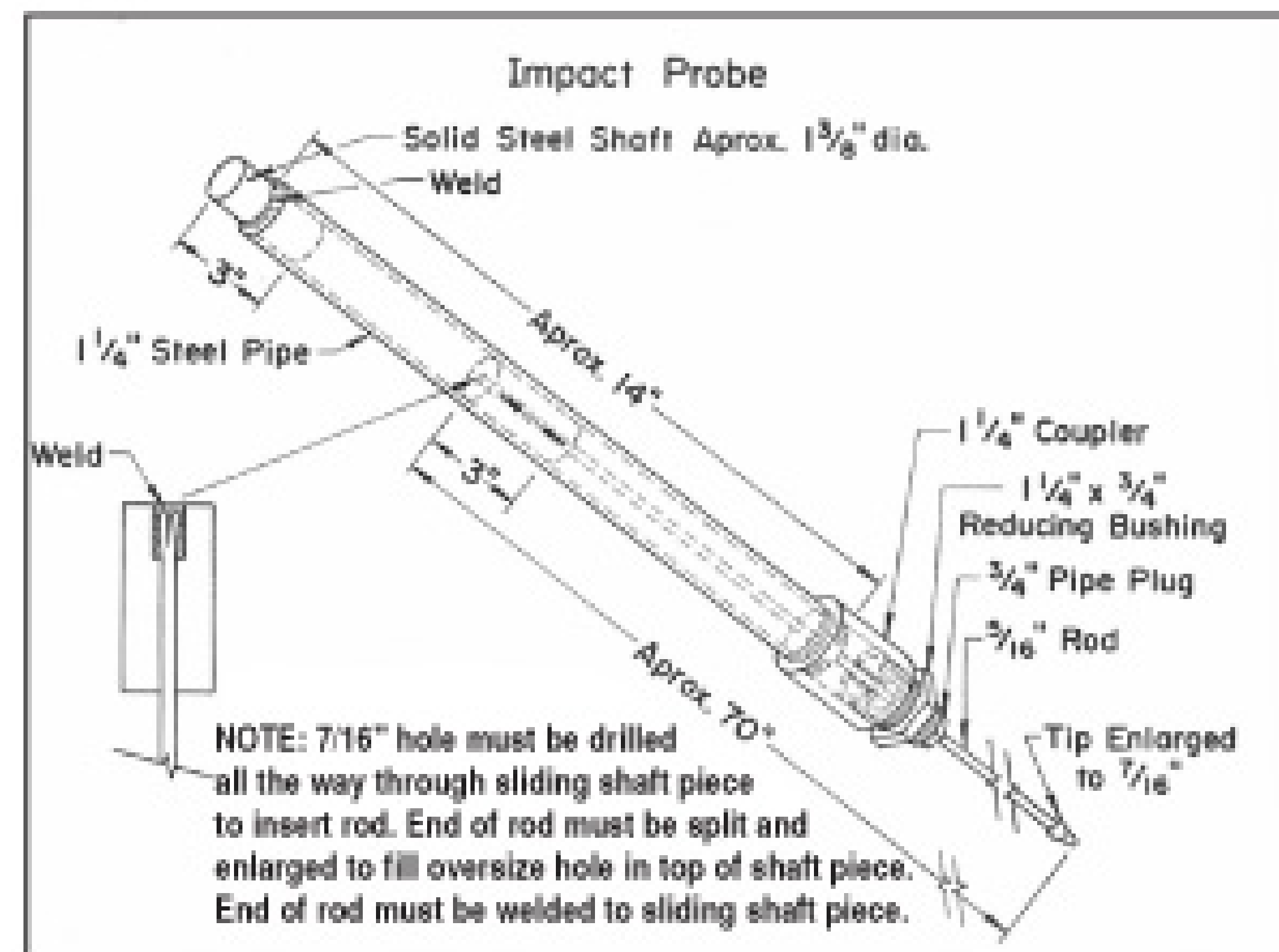

and beds. Again, the top of the rock layer has a distinct feel, and not at all like a concrete tank or plastic pipe.

The impact probe also can be driven through the rock layer, letting the user know when it hits soil again. In this way, the depth to the rock layer can be determined and the thickness of the rock layer can be measured. The total length of a trench, or the size of a seepage bed, can easily be determined without any digging.

A variety of probes are available commercially, or a machine shop with the proper equipment should be able to construct Fyle’s impact probe design using the drawing included here.

Note the tip of the 5/16-inch rod is enlarged. This is to decrease the friction on the rod as it penetrates the soil. It is important the tip be larger than the diameter of the rod, according to Fyle.

Another critical feature is attaching the rod to the shaft piece. Unless the top of the rod is split before it is welded into the shaft piece, it will likely pull apart

Readers are welcome to submit questions to the Answer Man. Send your question to COLE Publishing by e-mail to editor@pumper.com, by fax to 715/546-3786; or by mail to P.O. Box 220, Three Lakes, WI 54562. We will pass your question along to Dr. Machmeier.



when the rod is “hammered” out of the ground.

An impact probe is a valuable tool for locating the various parts of an onsite sewage treatment system. This is particularly true of the older systems

where there are no plans available, or no surface evidence where any part of the system is located.

MANHOLE COVERS

Another convenient product Fyle points out is the tapered and notched manhole cover. The top manhole cover is at the ground surface for easy location of the septic tank. Safety and preventing unauthorized entry are the reasons for having another cover

difficult to remove. The advantage of a notched opening with a combination taper and notch is that the cover rests on the top of the notch and is readily removed.

The method to remove the cover located on the top of the septic tank is shown in the drawing. A chain is attached to a handle in the cover and the cover can be lifted out of the manhole by several means.

What about septic tank insulation?

Q In a cold, northern climate, what role would tank insulation play in septic system effectiveness?

A In Minnesota and other states with cold winters and a potential for minimal snow cover, the major purpose of insulating a septic tank would be to prevent system freeze-up. In some cases additional heat is added to the tank, particularly if the system is used infrequently.

I am not a bacteriologist, but I have learned from colleagues that one of the optimum temperatures for anaerobic bacteria is the temperature of the human body. This is rarely achieved in a septic tank, but activity by the anaerobic bac-

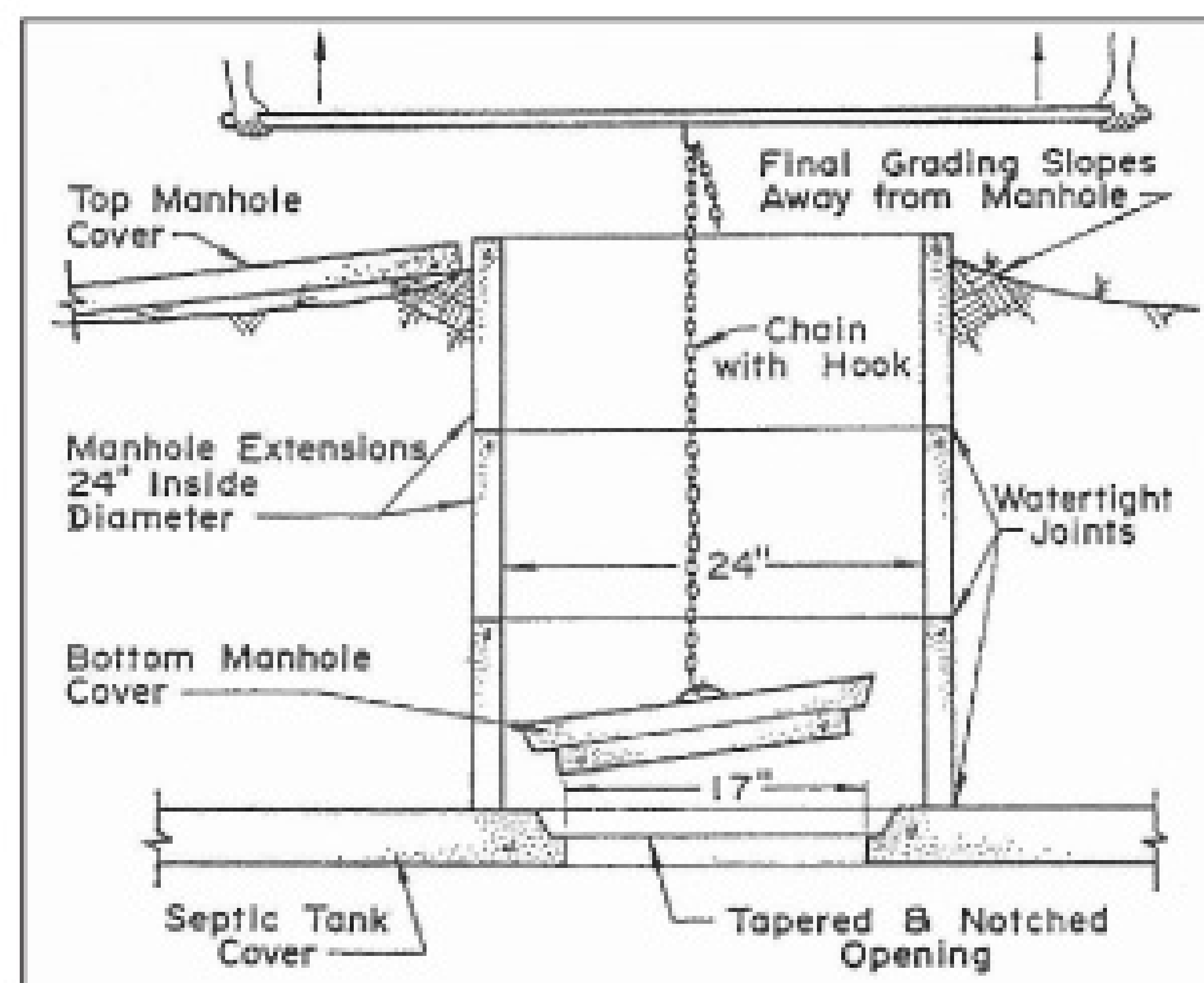

at the top of the septic tank.

If a septic tank manhole cover has a single taper, it can be

removed by the anaerobic bac-

(Fyle) has some solid advice about making pump-outs go quickly and easily. While many of you utilize the same tools and techniques, a quick review might help technicians who are newer to the pumping business.

teria in a septic tank would certainly increase as the temperature rises.

Typical septic tank temperatures in the summer in Minnesota are 50 to 60 degrees. Septic tank temperatures have become even cooler with the popularity of cold-water clothes washing.

Of course, heat is lost from the septic tank into the surrounding soil. An insulating layer of expanded polystyrene would reduce this heat loss and keep the tank temperature higher. Increased anaerobic bacterial activity would increase the rate of breakdown of sewage solids.

I believe it is a matter of record that septic tanks in the

southern United States have a slower buildup of solids than tanks in northern regions. This is likely due to a difference in the temperature inside the septic tanks.

There is a trend for local sanitary codes to require pumping septic tanks every three years and to increase the required size of residential septic tanks. Given the trends, there is little need to worry about increased bacterial activity. The septic tank will be serviced and the solids removed long before any danger of the tank filling with solids. The tank needs to be kept from freezing under severe weather conditions. To prevent freezing is the reason for the insulation. ■

Quality People Doing Quality Work

DOT Industrial Vacuum Hoist Units



DOT Industrial Vacuum Units



Thank you Beckman Production of Michigan for purchasing two 2500 gallon DOT Industrial Units.

Portable Restroom Service Units



IN STOCK - 650/350 gal.
Call for Details
Ready for Immediate
Delivery -
Priced at
\$55,500

Slide-In Units

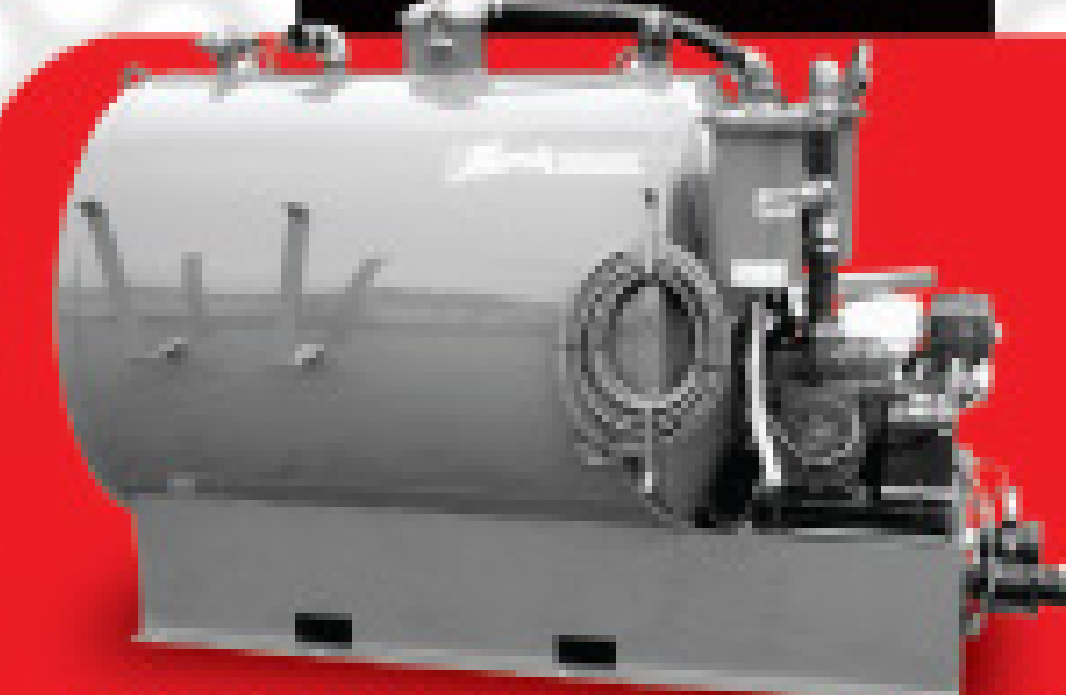

Thank you Lethbridge Truck & Eq.
from Alberta, CA for purchasing this
350/150 portable toilet restroom unit.

Slide-In Units



Thank you Duke Kelso of CA for
purchasing this 300 Gallon slide
in unit. More units in stock,
please call for details.

"DON'T BE EMBARRASSED AGAIN!" HOW AWFUL...

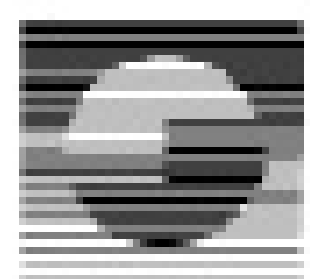

800-622-8768
sweetair.com

SWEET SEPTIC SYSTEMS, INC.
5701 Mother Lode Drive • Placerville, CA 95667
Fax: 530-622-1087

SWEET AIR™ FILTERING DEVICE

HOW WONDERFUL...



P.O. Box 1107 - 135 E Mile Road - Kalkaska, MI 49646
p: 231.258.4870 - f: 231.258.2019 - sales@marshind.com

800.952.1537 - WWW.MARSHIND.COM

Toll Free 888-207-2074

Fax (479) 770-6089

WILCOX TRUCK SALES, INC.



Lowell, Arkansas

SINCE 1978

I-540 Exit #78 & Hwy 71B

2 hours East of Tulsa or 1.5 hours South of Joplin

www.wilcoxtrucksales.com

1990 Peterbilt 379



Big Cam Cummins
400 HP, 13 Speed,
In Process of New
80 Barrel Vacuum
Tank, New Jurop
R260 Vacuum Pump, New
Paint, New Steer Tires, (8) New G167 Driver Caps,
Excellent Truck

1987 International F9370

Big Cam Cummins, 350 HP, 9
Speed, Hendrickson Suspension, 236" WB,
Budd Wheels,
70 Barrel
Vacuum
Tank,
Gardner
Denver Pump



Septic-Scrub™

The Demonstrated Drainfield Restoration/Maintenance Solution

Backed By Science ■ Proven with Experience ■ Many Satisfied Homeowners

Septic-Scrub™ is a superior product for the maintenance and restoration of septic system drainfields. Customers appreciate that it is environmentally safe, contains no organic chemicals and does not produce any toxic by-products. Most importantly, **Septic-Scrub works.** It breaks down sulfide buildup in the biomat and soil to allow for better water absorption.

Learn more about Septic-Scrub at www.arcan.com.

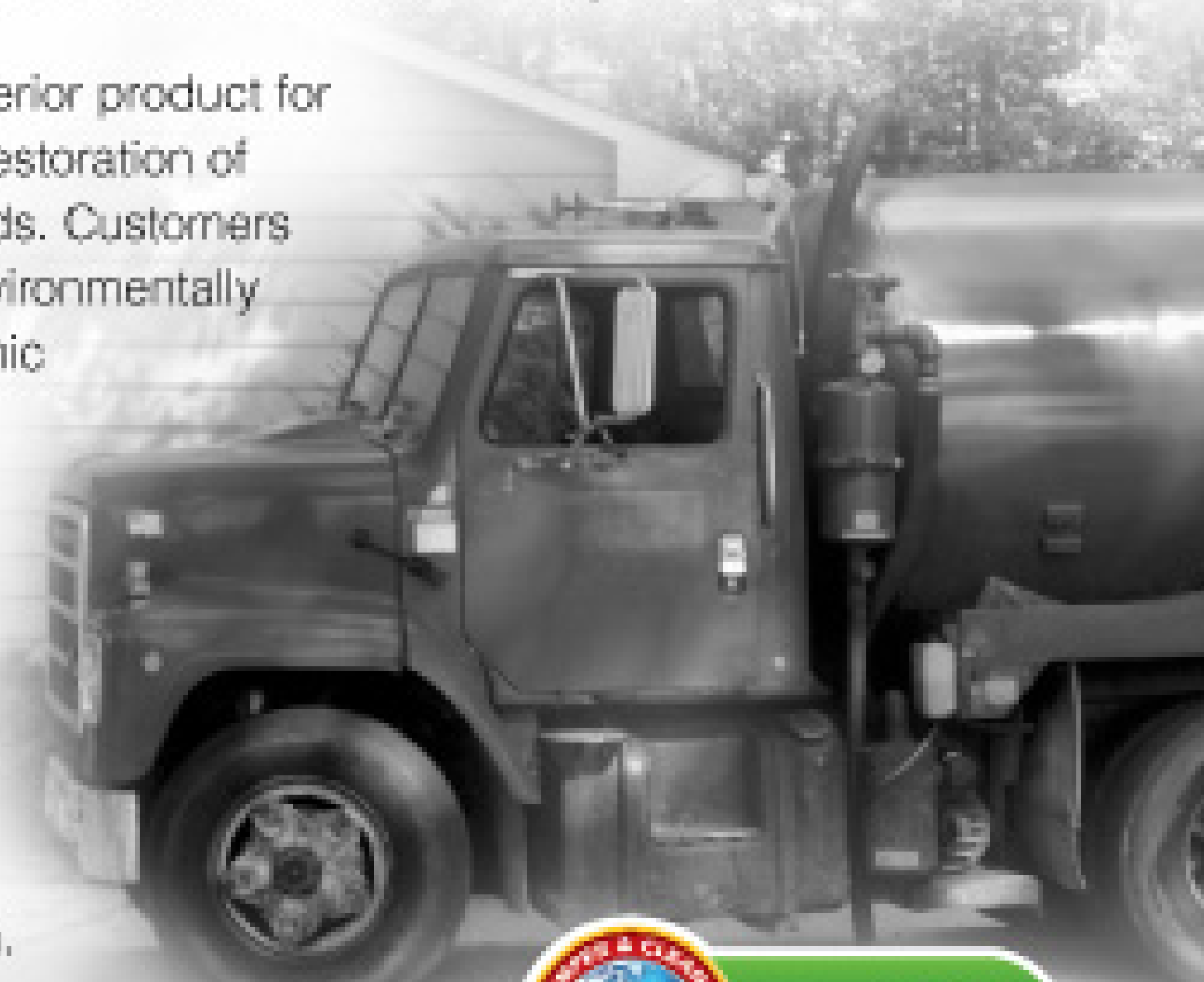

arcan

P.O. Box 65
Scotch Plains, NJ 07076-0065

For information on increasing sales and providing a valuable service to your customers, call Arcan Enterprises at **888-35ARCAN (352-7226)**



wallenstein

portable sanitation

The most rugged, dependable,
longest lasting vacuum pumps
in the industry!



Model 151



Model 202



Model 302



Model 402



Model 151
Engine drive



Model 302
Engine drive

- > Quality construction
- > Rugged design
- > Wide fiber vanes
- > Easy internal access
- > Low noise level
- > Two year warranty

Series	Rating CFM	Vacuum "HG	HP $\frac{1}{2}$ HP Engine	Tank Size US Gallon
151	80 @ 1750	27	5.5	500
202	115 @ 1150	27	11	750
302	165 @ 1150	27	13	1100
402	200 @ 1150	27	18	1500+

CALL FOR PRODUCT LITERATURE AND
YOUR NEAREST AUTHORIZED DISTRIBUTOR

Toll Free 1-800-801-6663
email info@wallensteinpumps.com

Seal it Tight! Seal it Easy! Seal it Fast!



- Easy 10 minute installation!
- Secure fit for all systems!
- Made & sold by septic installers!
- Prevent ground water infiltration and save money at the same time!



Apply foam sealant to tank.



Place ring over opening and apply foam.



Place plastic maintenance pipe on ring.



Install lid.

Are you tired of using risers that are too tall or too short for the job you are completing? Plastic riser pipe will give an exact height each time. Try our system and you will never have to carry concrete pipe and lids again. Save time by not having to assemble multiple sections.

Seal-R™ Lids Available in 12", 15", 18", 24", 30", 36".
Seal-R™ Rings Available in 18", 24", 30".
Inner Safety Lids Available in 18", 24".

Seal-R™ Lids can be personalized. Seal-R™ Lids are constructed with UV additive to resist degradation from exposure to sunlight.

For more information, call us today!

BrenLin Company, Inc
Manufacturers of Seal-R™ Products
Herman, MN
888-606-1998
Fax 320-677-3001 • Email brenlin@brenlinet.net

www.seal-r.com

Check our website for specs



NEW! WetVac

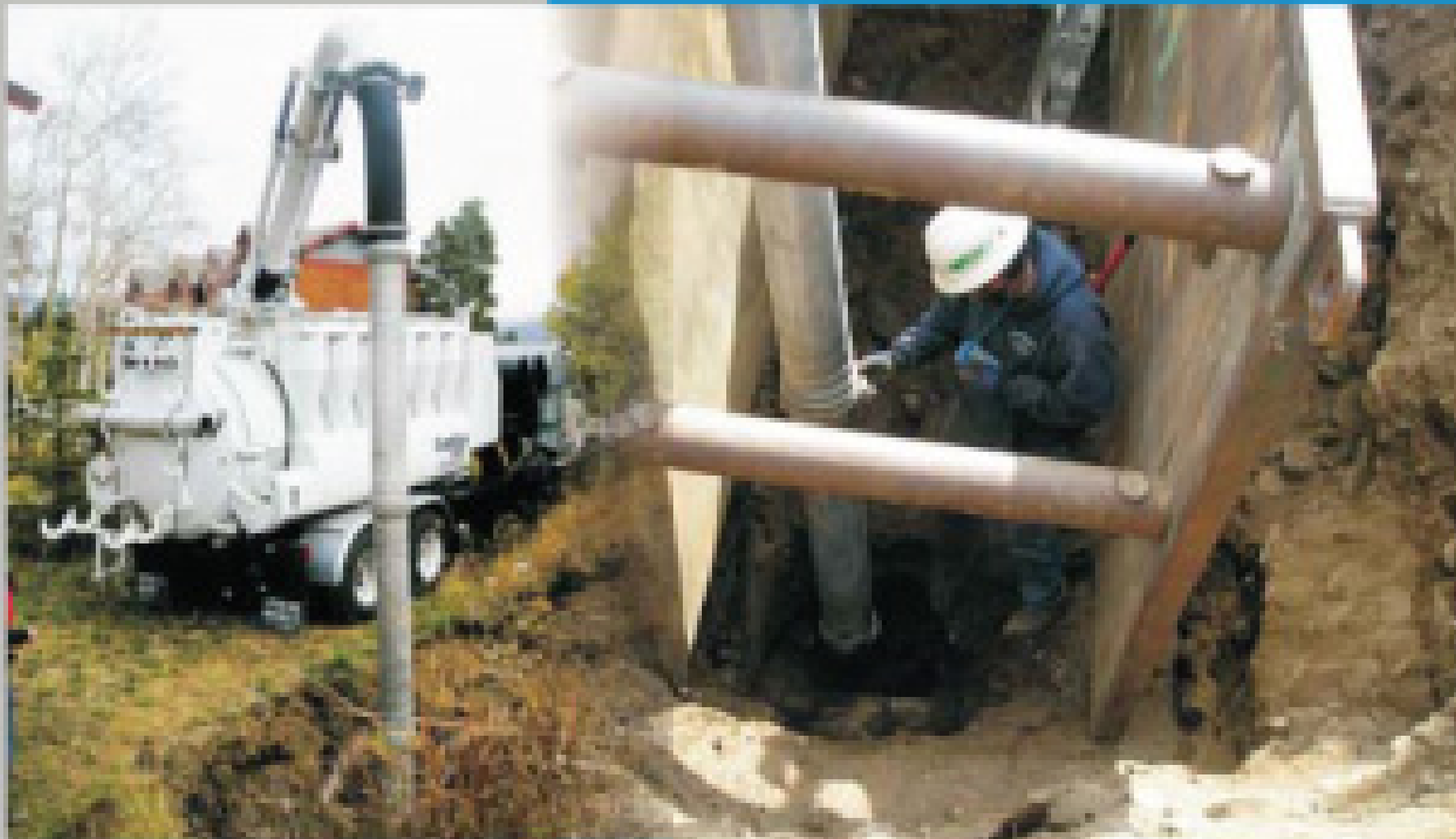

PARTSEXPRESS
A Division of GapVax

*"The Perfect Fit"
for all your parts & accessory needs*

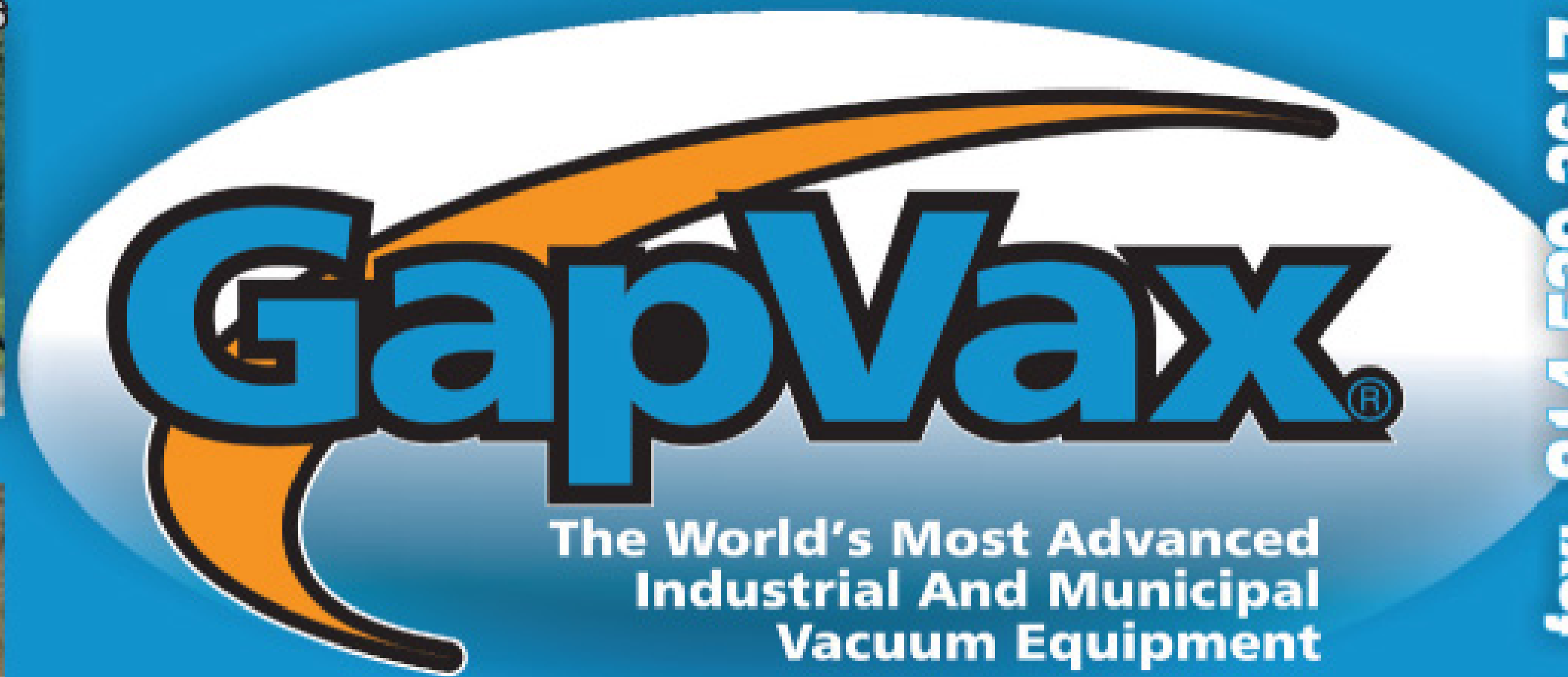
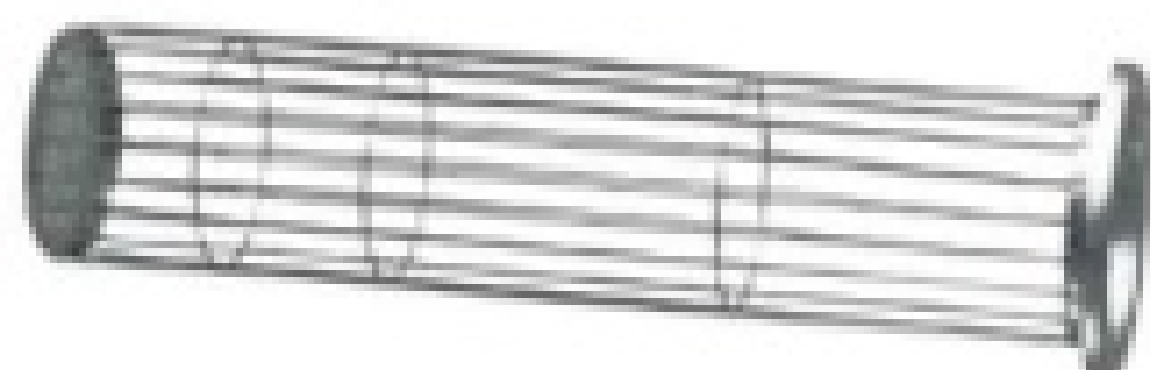

The World's Most Advanced
Industrial And Municipal
Vacuum Equipment

Industrial Vacuum Equipment WetVacs

Combination JetVac Trucks Hydro-Excavation Trucks

Skids Cyclone Trailers Stand-Alone Baghouses

Sound Enclosures Parts & Accessories

*Looking for a used truck or used equipment? Check our website sale ads!
We also offer rental units – call for details!*



If you want to save on taxes now's your chance—
we build top quality equipment that will
increase your profit and your success!

**PartsExpress is offering 10% off list price
for the month of December - call Scooter
today and place an order for all your
quality parts and accessory needs!**

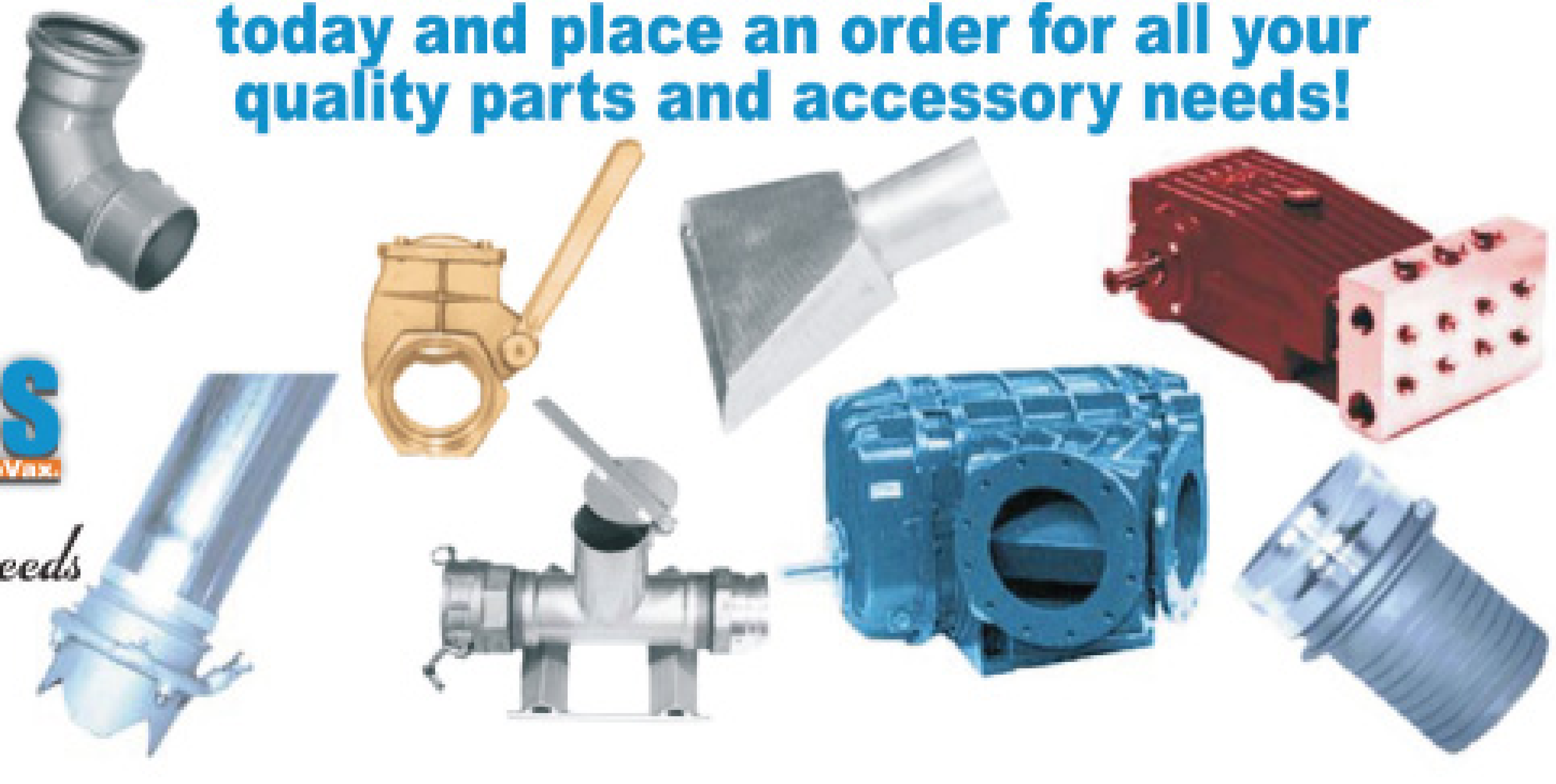

www.gapvax.com Toll-Free U.S./Canada 888-442-7829 814-535-6766 fax: 814-539-3617



NAWT Responds to Ohio Legislator's Criticism of Onsite System Maintenance

By Tom Ferrero

The National Association of Wastewater Transporters doesn't have the resources to become involved in every state and local legislative fight, but we want to respond to concerns arising from them. For example, Bart Clark, a professional engineer with Oakwood Environmental Associates in Warren, N.Y., sent a letter after the Department of Conservation updated some onsite regulations without notifying the stakeholders. Although annoyed by the omission, Clark's key concern was that the new rules required counties to have management plans, yet set no standards or criteria for onsite inspections, and did not appoint anyone to do them. Clark felt the onsite industry wasn't knowledgeable enough or prepared for the responsibility.

Using NAWT's database, I relayed Clark's concerns to 50 key people in the state. Many called or e-mailed him, providing information on NAWT's training programs and state association certification courses. Later, Clark thanked me for getting the word out and putting the right people together.

A similar situation happened in Ohio. To set the stage, the Public Health Council adopted onsite rules that became effective on Jan. 1, 2007. A coalition of manufacturers from the onsite industry then petitioned legislators, claiming that the amended code was unfavorable to new technologies. They were correct. The House rescinded the bill in July, and created the Home Sewage and Small Flow On-site System Sewage Treatment System Study Commission to recommend efficient and effective ways to treat sewage. The commission's report is due Dec. 31, 2008.

In September, 18th District Ohio State Sen. Timothy Grendell (R-Chesterland) wrote a memorandum to the commission. In it, he stated that periodic inspections are infeasible: Most local health districts don't have the money or personnel to conduct them, third-party private companies are untrustworthy, and landowners can't afford paying the salaries of newly hired field sanitarians or sophisticated, costly onsite systems.

In his letter, Grendell proposes allowing local health districts to establish their own rules. He believes that the cheapest system meeting minimum health standards is all that should be required, and that holding tanks are unnecessary. In short, the new technology is being pushed without any clear evidence that it is needed.

WHITE PAPER

In response to Grendell's mindset, the NAWT Board of Directors composed the following White Paper:

Members of the National Association of Wastewater Transporters service septic or decentralized onsite wastewater treatment systems. NAWT's mission is to represent these service providers on a national level and offer educational opportunities and credentialing. We are partners with the U.S. Environmental Protection Agency and 11 other national organizations in a Memorandum of Understanding that support onsite systems.

Our endorsement is well founded. In 1995, the U.S. Congress asked the

EPA, "What are we going to do with all these septic systems? Do we need to sewer the country? All we hear are horror stories about failing systems." After researching the facts, EPA responded to Congress in 1997. The report, Document 832R97001B, is at epa.gov. Here are its highlights:

1) Adequately managed decentralized wastewater systems are cost-effective, long-term options for meeting public health and water quality goals, particularly in less densely populated areas. Unlike past practices of installing onsite systems to serve until the sewers come, today's technology can be installed almost anywhere. In addition, these systems help promote better watershed management by not transferring water from one watershed to another as is the practice of most municipal treatment plants.

2) Decentralized systems serve approximately 25 percent of the U.S. population, and approximately 37 percent of new development.

3) For communities with small populations, the most cost-effective option is often onsite decentralized systems. These systems are suitable for various site conditions including shallow water tables, bedrock, low-permeability soils, and small lots.

4) Onsite system expansion is inhibited by:

- Lack of knowledge and misperceptions by homeowners, service providers, and regulators.
- Absent, vague, or inapplicable state legislation and the splitting of state and local governments. Such actions create confusion over accountability and program coordination, giving centralized facilities the upper hand and denying onsite systems equal stature.
- Inflexible and prescriptive regulatory codes that often allow only conventional systems. Where alternative systems are approved, the permit process is often lengthy, resulting in the selection of inadequate onsite systems, needlessly expensive centralized systems, or their expansions.

5) Few communities have developed the necessary organizational structures to manage onsite systems. Without maintenance, they will fail to treat wastewater properly.

6) Homeowners and developers are often unwilling to accept the responsibility and potential liability associated with onsite systems.

7) The EPA's Construction Grants program and the Clean Water State Revolving Fund program are the major sources of wastewater treatment facility funding, but they are generally available only to public entities. Federal and state grant and loan programs make it difficult for privately owned systems to obtain these funds.

SOLVING THE PROBLEM

Working with MOU partners, NAWT provides education to homeowners and industry participants. Our nationally acclaimed programs cover onsite installa-

NAWT DOESN'T HAVE THE RESOURCES TO BECOME INVOLVED IN EVERY STATE AND LOCAL LEGISLATIVE FIGHT, BUT WE WANT TO RESPOND TO CONCERNS ARISING FROM THEM.

tion, operation and maintenance, inspections for real estate transactions, vacuum truck technician training, and waste treatment training. We have certified more than 3,000 members.

NAWT believes that good management begins with understanding how system components work, how they are installed, and how they are maintained. Arizona, New Mexico, and Delaware have made NAWT training part of their onsite management requirements, and California, Texas, Michigan, and Massachusetts have recognized it as an integral part of their continuing education programs. NAWT cooperates with Florida and Minnesota and their long-standing education programs, and provides courses in Ohio through the Ohio Waste Haulers Association. NAWT partners with other national and regional organizations to offer the best training programs possible, while fulfilling its core responsibilities to pumpers and maintenance providers.

Unfortunately, participation in these courses is still directly proportional to regulatory requirements in many states. Counties in Colorado and New Mexico, however, took the lead and required NAWT certifications before the states adopted the requirements.

Arizona is an example of a state with a successful regulated program. Its Department of Environmental Quality requires training and certification for individuals inspecting onsite systems for real estate transactions. A strict reporting requirement enables the state to populate its database with systems installed before 2001, when records were lacking. Regulators are using issues that become apparent through inspections to further refine state code.

In conclusion, Ohio is not alone in its efforts to manage and upgrade many existing onsite systems. One by one, each state is working on pieces of the solution. In most cases, the status quo is unacceptable. A management program for all onsite systems is a necessity. NAWT believes that states must pass strong regulations based on sound science, then authorize counties to enact them. Low interest funding is needed to help property owners implement repairs, and the education of homeowners, service providers, installers, inspectors, regulators, and every segment of the industry is imperative!

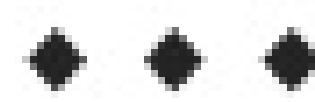

If you see similar legislative activities happening in your state, get NAWT involved. We can make a difference. Call 800/236-6298 or visit www.nawt.org.

Join NAWT Now!

Independent Member (\$150)

Company Member (\$300)

Associate Member (\$300)

State Association Member (\$100)

Be a part of the pride and professionalism that all NAWT members enjoy!

Contact NAWT today:

1-800-236-NAWT (6298) Fax 267-200-0279

www.nawt.org



DENVER TRUCK SALES

Nobody Beats Our Quality!



2000 IHC 9400 & 9900

14,000 LB f/a, 3406E Cat 435-475 hp, Jake, 15-18 speed transmission, 46,000 LB rears Hendrickson air suspension. New 3360 gallon tank HXL-400 pump serviced and checked.

From \$62,950 plus F.E.T. on the tank



2001 Peterbilt 379

14,600 lbs. FA, C-15, 475 Cat, Jake, RTLO-18918 Transmission, RT-46160 on Pete air tract, 46,000 LB 4-way locks, New 3360 Gallon Tank, HXL 400 pump.

From \$79,950 Plus options and F.E.T. on the tank



1996-2001 Western Stars

435-475 hp Cat, Jake, 18 speeds 46,000 LB rears on Hendrickson air suspension. New 3360 gallon tank, HXL-400 Masport pump, serviced and checked.

From \$64,950 plus F.E.T. on the tank



2001-2003 KW T-800 Series

C15 Cat 475 hp, Jake, RTLO-16918 transmission, RT46160 46,000 LB 4.33 ratio, new 3360 gallon tank, Masport HXL-400 pump, new paint serviced and checked.

From \$79,950 plus F.E.T. on the tank

Complete Line of Pumps and Parts

Easy Financing and Lease-To-Own WAC!

Denver Truck Sales • 5293 Vasquez Blvd. • Denver, CO 80216
 Phone: 303-291-0960 • Fax: 303-291-0244 • www.denvertruck.com

CLEAR COMPUTING *with* INSIGHT

Total Activity Control
Street Eagle GPS

Reduce Operating Expenses

More profitable in any economy!

★ TAC 2009.Next ★

- Rock solid, so it works, is easy to use and fast!
- No more working HESS (Holidays, Evenings, Saturday, Sunday)
- Calendar Dispatch
- In-Vehicle Garmin
- TACTrackerPRO
- Your Company, Your Way, Anywhere, Anytime

21

YEARS OF
INDUSTRY
LEADERSHIP
1988 - 2009



Clear Computing

(888) 332-5327

www.clearcomputing.com



- Lease or Buy
- FREE Trial

Insight USA

(301) 866-1990 x201

www.mds-inc.com

IN STOCK!
Financing Available

Year-End Savings!

2500 Gallon Septic Tank

Masport HXL15 - 350 CFM,
6" discharge, (2) aluminum cabinets.

2008 Ford 750 33,000 GVW,
260 HP Cummins,
6 speed, air brakes.

\$85,977

Lease from
\$1719 mo.



3600 Gallon Septic Tank

Masport HXL400 water cooled

2008 International 4400

10 speed transmission

\$105,245 Plus F.E.T.

Monthly Lease From...\$2,104



2008 Hino Model 338

260 HP 6 spd. trans. ,air brakes

2000 Gallon Tank

Masport HXL4, dual service,
wash down, Tow package
Toilet carrier.

\$78,975 F.O.B. Kansas City
Lease from **\$1579 mo.**



2008 Sterling Bullet Restroom Service

Cummins 305 HP, automatic trans. 7000 lb front
and 13,500 lb. rear axle, AM/FM-CD.

1250 Gallon Tank

Masport HXL4, dual service,
Burks DC 10, toilet carrier.

\$69,900 F.O.B. Kansas City

Monthly From...\$1,205



800-264-8348 Voice
573-547-8420 Fax
573-450-5196 After Hours
www.semotank.com

Your Turn Key Solution To Trucks
"Ready to Go"

Contact:

Glenn "Mac" McCallister
gmmccallister@semotank.com

Donnie Moyers
tdmoyers@semotank.com

Jeff Kalp
jnkalp@semotank.com

SEMO/BAKER **ACRO**

United to Broaden Your Tank Services

456 Semo Lane, Perryville, MO 63775

2008 International 7400

56,000 GVW **Auto Transmission**

3600 Gallon Masport HXL 400 water cooled, 400 CFM pump,

Hot shift PTO, 20" top man way, 20" rear cleanout

Rear sump with 6" discharge

and 6" flange.

Large tool box

\$114,200

Monthly Lease
As Low As...

\$2,284



EXCEL

EQUIPMENT & SUPPLY CO INC.

1-800-392-3513

Tel: 317-882-1300
Fax: 317-889-0052

2008 Sterling Bullet Restroom Service

Cummins diesel-305 HP, automatic trans.,

7000 lb ft. /13,500 lb. Rr., Exhaust Brake.

1250 Gallon Tank (2) compartment

Masport HXL4, dual service,

Burks DC 10 wash down,

Tow package and toilet carrier.

\$70,300 from... **\$1406** mo.

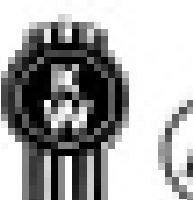
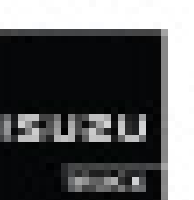
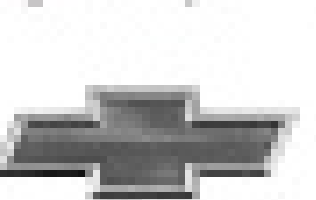
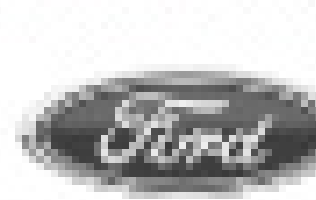

www.excel-equipment.com

585 Sayre Court, Greenwood, IN 46143

FINANCING

FOR ALL YOUR
NEW & USED EQUIPMENT

GIVE US A CALL TODAY!
866-769-2345



31 YEARS OF EXPERIENCE
WORKING FOR YOU!



- Application Only to \$250,000.00
- Simple Approval Process
- Lease or Loan Options
- Aggressive on Used Equipment
- Start-up Programs
- Flexible Financing Available

CAPITAL PARTNERS

101 N. Main Ave. Suite 215
Sioux Falls, SD 57104
www.yourcapitalpartner.com
866-769-2345

**YOUR ONE STOP
FINANCING PARTNER**

Competitive Pricing, Simple Processing,
Honest Answers



Our **VALUE** goes deeper than you realize.

When it comes to portable sanitation solutions, WALEX delivers much more than blue deodorizers and accessories. We're giving you **innovative research & development** that has set all the current standards for excellence. You're getting **proprietary breakthroughs** that our competitors can only emulate. When you choose WALEX, you're not only getting **the best on the market today** — you're also supporting your industry's future.



For more information, contact us at **910.371.2242**, toll-free **800.338.3155** or visit our website at **www.walex.com**.

Product News

Phoenix Offers WX-D Belt Filter Press

The WX-D dual gravity zone belt filter press system from Phoenix Process Equipment Co. features an integral third belt pre-thickener and

extended gravity and wedge zones. Because the pre-thickener section is driven independently from the press, it utilizes a more porous belt material that accelerates drainage, allowing for higher belt speeds and increased hydraulic capacities. The pre-thickener belt and press can process sludge from two different sources, allowing for simultaneous thickening of one sludge and the dewatering of another. For more information: 502/499-6198; www.dewater.com.



WX-D dual gravity zone belt filter press system from Phoenix Process Equipment Co.

Water Cannon Offers Replacement Pumps

Water Cannon has expanded its line of General Pumps, offering replacement units with flow rates up to 58 gpm and adjustable pressure up to 7,000 psi. The pumps feature a precision-machined brass manifold designed to hold up in extreme use, including accidental freezing. The large capacity oil crankcase and triplex ceramic plunger design add durability. For more information: 800/964-9274; www.watercannon.com. Expo booth 8041.



General Pump replacement unit from Water Cannon

Hannay Enhances N700 Reel

Hannay has added a separate non-sparking ratchet assembly unit to its N700 spring rewind hose reel. The new design provides better access to the pawl and pin, even in hard-to-reach machine applications. Redesigned seals in the heavy-duty spring motor and a redesigned arbor provide added protection in dirty environments and simplifies maintenance. The position of the hose riser also has been adjusted to improve alignment of the hose on the drum during retraction. The reel can accommodate single 3/8-inch or 1/2-inch I.D. hose and is designed to operate at up to 3,000 psi and temperatures from -20 degrees to 225 degrees F. The standard inlet is a 90-degree swivel joint with 1/2-inch female NPT threads. The standard outlet has 1/2-inch female NPT threads. For more information: 877/467-3357; www.hannay.com. Expo booth 3161.

Thompson Offers JSC Solids Handling Jet Pump

The 6-inch JSC Series solids handling Enviroprime pump from Thompson is designed for flows to 2,500 gpm, maximum heads to 195 feet and solids up to 3 inches. Featuring the Enviroprime compressor-assisted dry priming system to prevent blow-by, the pump can dry-prime and re-prime automatically. The cast-iron pump is available with the Silent Knight canopy, enabling it to operate at 67 decibels. For more information: 800/767-7310; www.thompsonpump.com. Expo booth 8139.

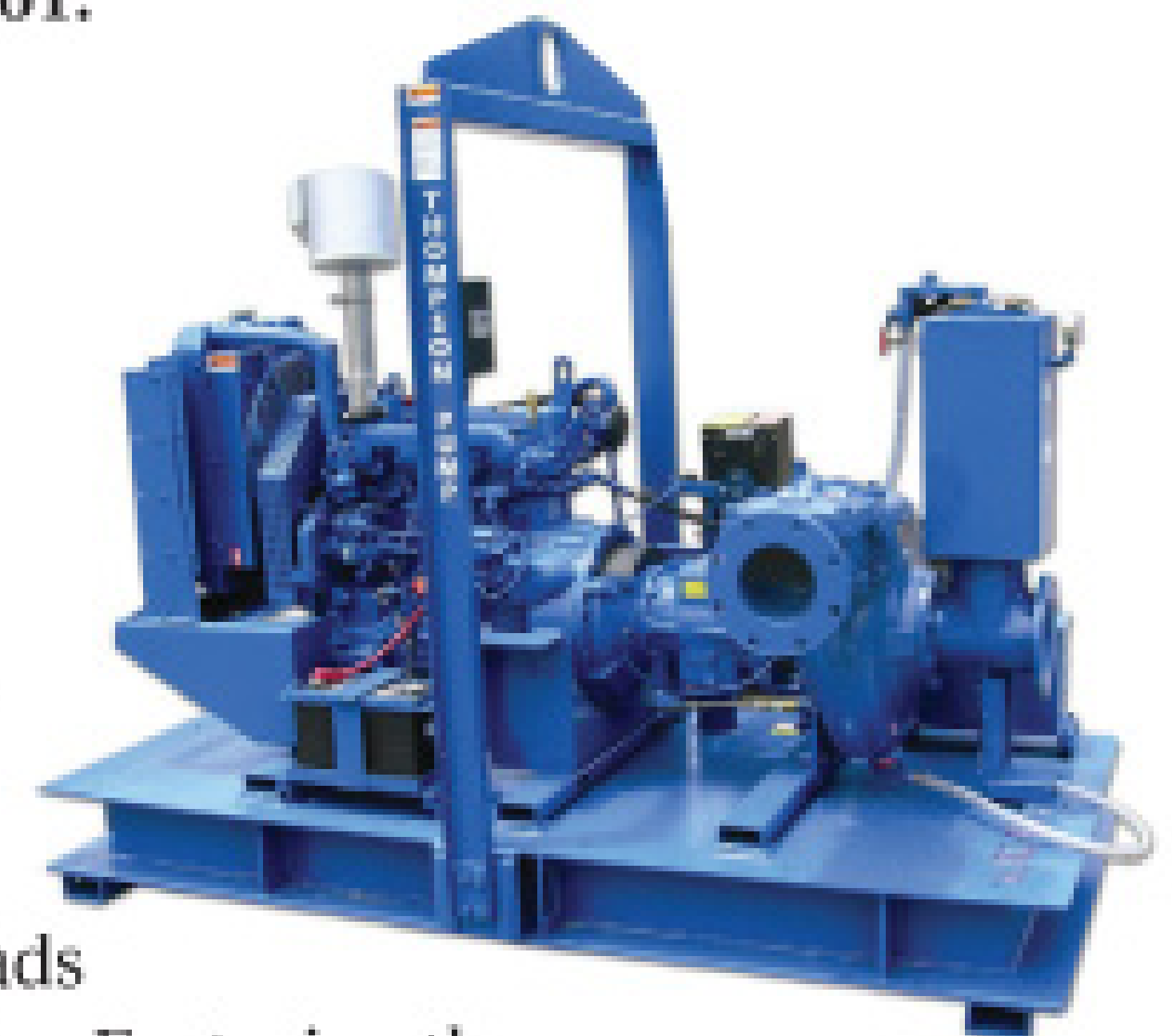

Enviroprime pump from Thompson

Western Mule Offers P-20 Fold-Away Bumper Crane

The P-20 fold-a-way bumper crane from Western Mule features 2,000 pounds of lifting capacity, six different boom positions, and vertical boom storage that enables it to fold compact and out of the way when not in use. A lighter duty P-10 crane is designed to lift up to 1,000 pounds and is offered with DC, AC and manual hand-crank models. For more information: 559/266-6977; www.westernmule.com. Expo booth 3027. ■



Featured in an article?

Make the most of it!

REPRINTS AVAILABLE

We offer: Full copies of the original magazine
Hard copy color reprints
Electronic reprints

Visit pumper.com/editorial for articles and pricing
E-mail jeffl@colepublishing.com or call 800-257-7222

We pay attention to the details.

- Fabricated to the best industry standards using the highest quality products available
- Custom configurations to your specifications
- VISA, American Express, MasterCard, & Discover
- Fast, same day shipping, low freight rates



**ATLANTA
RUBBER &
HYDRAULICS**

1640 D Sands Place
Marietta, GA 30067
Toll Free: 800.282.6272
Phone: 770.955.5225
Fax: 770.955.2377
e-mail: dragsdale@atlantarubber.com



CUSTOM PORTA-JOHN UNITS

STAINLESS STEEL & STEEL UNITS
CALL FOR INFORMATION

TANKS TO YOUR SPECIFICATIONS

PUMP DISTRIBUTOR

- * BATTIONI
- * JUROP
- * BOWIE
- * MASPORT
- * FRUITLAND
- * MORO

Pump Rebuild Kits In Stock

**CALL TODAY FOR
INFORMATION
OR PRICES ON
TANKS, PUMPS
AND ALL PARTS**

Secondary Shutoffs

Sight Glasses, Valves & Couplings

12" Primary Shutoffs

21" & 36" Manways



CUSTOM SKID UNITS



**Specialty B
SALES**

800.364.7307

2100 EAST BOOTH ST. • SEARCY, AR 72143
Fax: 501.279.0003 • E-mail: sbs@cdlworld.net



PRECISION TANK & EQUIPMENT CO.
www.precisiontank.com | 1.800.258.4197

CENTRAL ILLINOIS Manufacturer Celebrating 40 years of steel and stainless steel tank equipment innovations. Tank sizes from 100 to 5000 gallons in stainless steel or steel.

Manufacturing plants in Virginia and Athens, Illinois bringing quick completion of your pumper truck!
40 years of excellence!

PRECISION TANK & EQUIPMENT CO.



Modular Vacuum Drop In Units

Trailer Mounted Vacuum Tanks



Vacuum Tankers

Street Flusher Tankers

Standard models or custom built units

Single or multiple compartments

1.800.258.4197



A Subsidiary of The Gorman-Rupp Company™

12 VOLT DC HIGH HEAD WASHDOWN PUMP

- 1 HP Washdown Duty Motor for Severe Operating Conditions
- Investment Cast 316 Stainless Steel, Cast Iron or Cast Bronze Construction
- All Models Equipped With High Efficiency Stainless Steel Impeller
- Discharge Port Rotates in 90° Increments
- Four Front Drain Plugs
- Maximum Flow 56 GPM
- Maximum Head 80 Ft. (35 PSI)
- Maximum Temperature 200° F



The AMT 12 Volt DC Washdown Pumps are designed for pumper, septic service, OEM, and marine applications requiring a DC motor. The motor has a one hour duty rating and is furnished with a grade 303 stainless steel shaft. Washdown Duty Pumps are available in a variety of construction and seal materials to meet your specifications. Pull-from-the-rear design for easy servicing without disturbing piping.

Call us toll free at **888-268-7867** or visit our website **www.amtpump.com** for more information.

American Machine & Tool
A Subsidiary of The Gorman-Rupp Company
400 Spring Street
Royersford, PA 19468



ALBERS / CADMAN
Emergency or Temporary Liquid Storage

- Safe, affordable enclosed storage.
- Up to 1.3 million gallons.
- Various agitator options.
- Neighbor friendly odor control.
- Blends in with surroundings.
- Fully transportable systems also available.

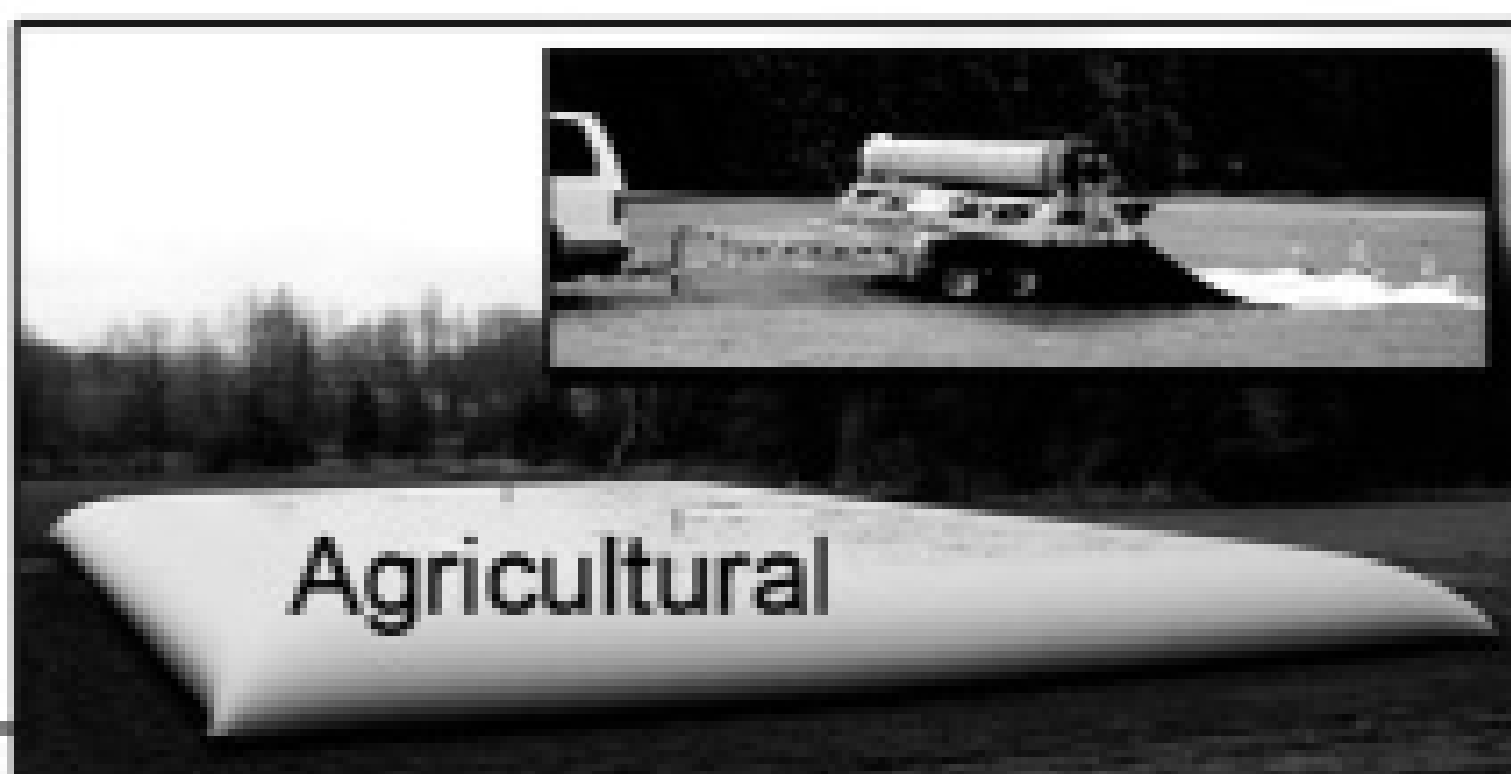

Agricultural



Municipal



Industrial

Your containment solution is only a phone call away.



Cadman
www.cadmanpower.com

38 Main St., Courtland Ont., Canada
1-866-422-3626 (519) 688-2222
Fax: (519) 688-2100



All In!

When you receive *Pumper* each month there is no need to bluff.

Join 25,000 of your industry peers each month who welcome *Pumper*, for the unlimited value it brings them. Each issue will show you new tools, tips to save on expenses, money-saving deals and much more.

800.257.7222 • www.pumper.com
Subscribe today to guarantee your winning hand!

NEED SOFTWARE?



The Leading QuickBooks® add-on Software for today's Portable Sanitation Business.

- Software now starting from \$49.95 per month. PC based.
- Interface with QuickBooks® -The Service Program generates your recurring route billing and seamlessly allows you to print the invoices in QuickBooks®
- Easily Manage Routes
- Palm and Windows PDA Handheld Support w/Remote Sync
- Track Pick-Ups & Drop-Offs
- Works with Mapquest® and Mappoint®
- Track Inventory at Multiple Locations
- 30-Day Money Back Guarantee-Leasing Available
- 30 Day No Risk FREE Trial with Weekly Training

866.480.1879
www.theserviceprogram.com



Sludge Mate
& Poly-Mate

The Flo Trend® Sludge Mate® and Poly-Mate® form an economical and simple to use sludge dewatering system. The Poly-Mate® conditions sludge through the addition of polymer prior to the dewatering process which occurs in the Sludge Mate®. These units are designed to dewater sludge from a multitude of waste stream sources including: water and wastewater treatment plants, septic tanks, car washes, industrial sumps and lagoons, grease traps, rendering plants, and food processing plants. The Sludge Mate® and Poly-Mate® are available in a variety of sizes and configurations, and are built to custom specifications.



Booths 5187 & 6187



DEWATERING MADE SIMPLE.

Flo Trend Systems Tel - 713-699-0152
707 Lehman St. 800-762-9893
Houston, TX 77018 Fax - 713-699-8054
sales@fлотrend.com

IT'S A **Bag Full**

pumper.com

- > Classifieds
- > Truck Stop Ads
- > E-zines
- > Product Categories

TRUCK TOWN

2601 East Hwy. 80 • Abilene, Texas 79601

FULL SERVICE VACUUM SYSTEMS SUPPLIER



1-800-727-0350

**GOOD ASSORTMENT OF CUSTOM SPEC TRUCKS
FOR YOUR VACUUM UNIT NEEDS**

LELY SEPTIC & OIL FIELD VACUUM TRUCKS
TROXELL TRAILERS



JEFF MULLICAN • HUBERT YOUNG • DENNIS ADAMS

Phone: 325-673-4642 • Fax: 325-673-4673
Web Site: www.truck-town.com • E-mail: truck@camalott.com

Celebrating 30 YEARS in business

Coagulants and Flocculants

for Septic, Grease, Municipalities and Industry

- Dewatering polymers for all dewatering equipment
- All forms: Dry and Emulsion
- Variety of packaging sizes to meet customer needs
- Both East & West coast shipping points
- Expert technical staff
- Specific solutions for our customers

Save Money
Save Time
Save Polymer

Call Toll-free: 877.771.6041

Aqua Ben Corporation
1390 N. Manzanita St. • Orange, CA 92867
www.aquaben.com • sales@aquaben.com

Wastequip Names Scott CEO

John G. Scott has been named president and chief executive officer for Wastequip Inc., Cleveland, Ohio, manufacturer and marketer of equipment used to collect, process and transport solid, liquid and semi-liquid waste and recycling materials. Scott served as president of the company's Specialty Group since April 2007. He succeeds Robert C. Rasmussen, 66, who is retiring after serving as Wastequip's CEO since 2001.

Aero-Stream Receives State Approval Renewal

Aero-Stream's septic system maintenance and restoration product has received renewed approval from the Wisconsin Department of Commerce and is listed on the department's Web site under Approved Plumbing Products. The company's remediation product also has earned Handyman Club of America approval.

Bradbury Joins Capital Connection

Pat Bradbury has joined Capital Connection and will be responsible for its East Coast operation, working with manufacturers and business owners to assist with equipment financing.



Pat Bradbury

The Service Program Names Ipolito Director of Training

The Service Program, developer of the QuickBooks add-on service and routing software for sanitation and rental companies, has named Melody Ipolito director of training.

Daimler Discontinues Sterling Truck Line

Daimler Truck North America will discontinue its Sterling truck line, effective March 2009. Daimler said the move was in response to depressed demand across the industry and changes in the company's markets. Dealers will continue to accept orders until Jan. 15. New truck sales will continue until dealer stocks are depleted. The company expects Sterling dealers will continue to perform warranty repairs and maintenance services, supply replacement parts and provide technical support. Launched in 1998, Sterling models have substantial overlap with offerings in the Freightliner line, but have achieved only one-fourth of Freightliner's market penetration. As a result of the decision to cease production, the company is closing its St. Thomas, Ontario, Canada, truck plant in March and will cease operations at its Portland, Ore., plant in June 2010 when current labor contracts expire.

obituary

McDonald Published Journal, Was Industry Sales Exec

Steven McDonald, publisher and editor of industry trade publications *Sanitation Journal* and *Septic Biz*, passed away Oct. 26 in Hanford, Calif. He was 52.

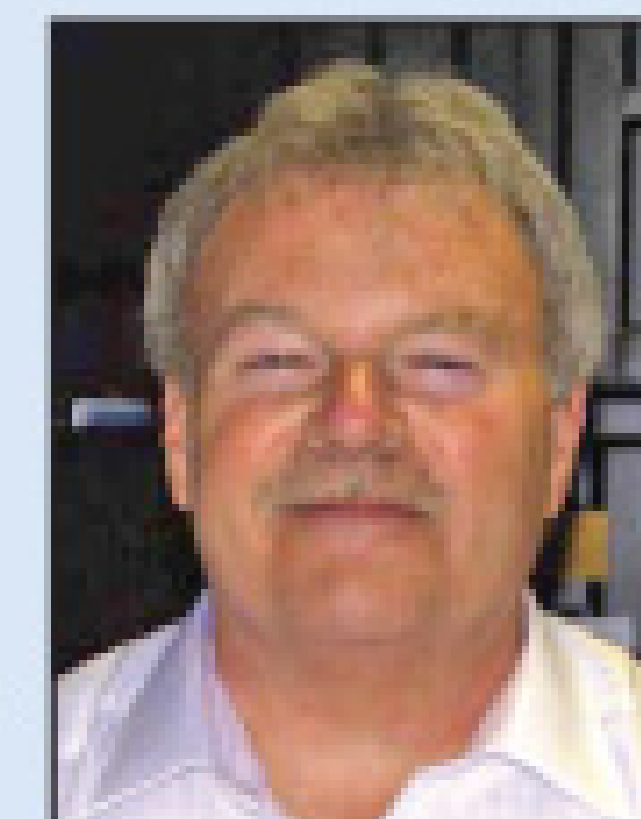

Involved in the portable sanitation industry since the 1970s, McDonald served as a sales executive for Olympia Fiberglass Industries, PolyPortables Inc. and Satellite Industries before starting *Sanitation Journal* in 2002. He launched *Septic Biz* recently.

Shortly before his death, McDonald was awarded the 2008 M.Z. Andy Gump Distinguished Service Award by the Portable Sanitation Association International. The award was officially announced at the annual PSAI conference in November.

"He was able to receive the award and was excited about it," says Kathy McDonald, his wife. "He felt it was an honor to receive that award. The industry was like another family to him. He met so many people through the years, and he loved the industry."

The 2007 Gump Award winner was the late Ed Cooper of PolyJohn Enterprises Corp., Whiting Ind. The award has been given since 1993, when it was started in honor of portable sanitation pioneer Andy Gump.

McDonald made his home in Lemoore, Calif. He is survived by his wife, eight children and seven grandchildren.

Satellite Industries Acquires Five Peaks Technology Product Line

Restroom manufacturer Satellite Industries will take over sales and operation of the Five Peaks Technology product line from Ameriform, Inc., according to a joint agreement announced by the two companies Nov. 11. The agreement ensures the continuation of the Five Peaks product line for existing and new customers, according to Todd Hilde, president and CEO of Satellite.

"Five Peaks products will remain as a popular choice for restroom operators with this joint agreement," Hilde said in the announcement. "Five Peaks' customers who may not be familiar with Satellite will find that we work hard at becoming a valuable partner by providing a high level of customer service through our area managers and internal support staff. That will certainly be our goal with Five Peaks' many loyal customers."

Ameriform, a thermoforming company in Muskegon, Mich., will focus on the core business of manufacturing, while transferring the sales and operations of Five Peaks to Satellite, based in Plymouth, Minn.

Satellite Industries adds the Five Peaks line to both Satellite and Synergy World branded products it already produces. Satellite celebrated its 50th anniversary this year.

For more information regarding Five Peaks, Satellite or Synergy World restrooms, trucks and deodorizers, contact Satellite Industries at 800/328-3332 or visit www.satelliteindustries.com. Expo booth 1122. ■

Mid Continent Truck Sales, Inc.

891 Adkins Hill Rd. • Norman, OK 73072 • 405-329-5365 • Fax: 405-329-5381 • After Hours: 405-288-6502 • www.vacuumtrucksales.com

Trucks - Trailers - Vacuum Tanks - Pumps



2001 IH 4700, DT466E, Allison auto, non-CDL, air brakes, new MEC 6500 vacuum pump, new 1100/400 vacuum tank.



2000 IH 4700, DT466E, 5-spd., non-CDL, double frame, new Wally 403HR vacuum pump, new 1600 gallon vacuum tank.



1998 Freightliner FL60, Cummins 5.9 (210 hp), 6-spd., Masport H75V vacuum pump, General 47 series triplex, 1100/200 gallon vacuum tank.

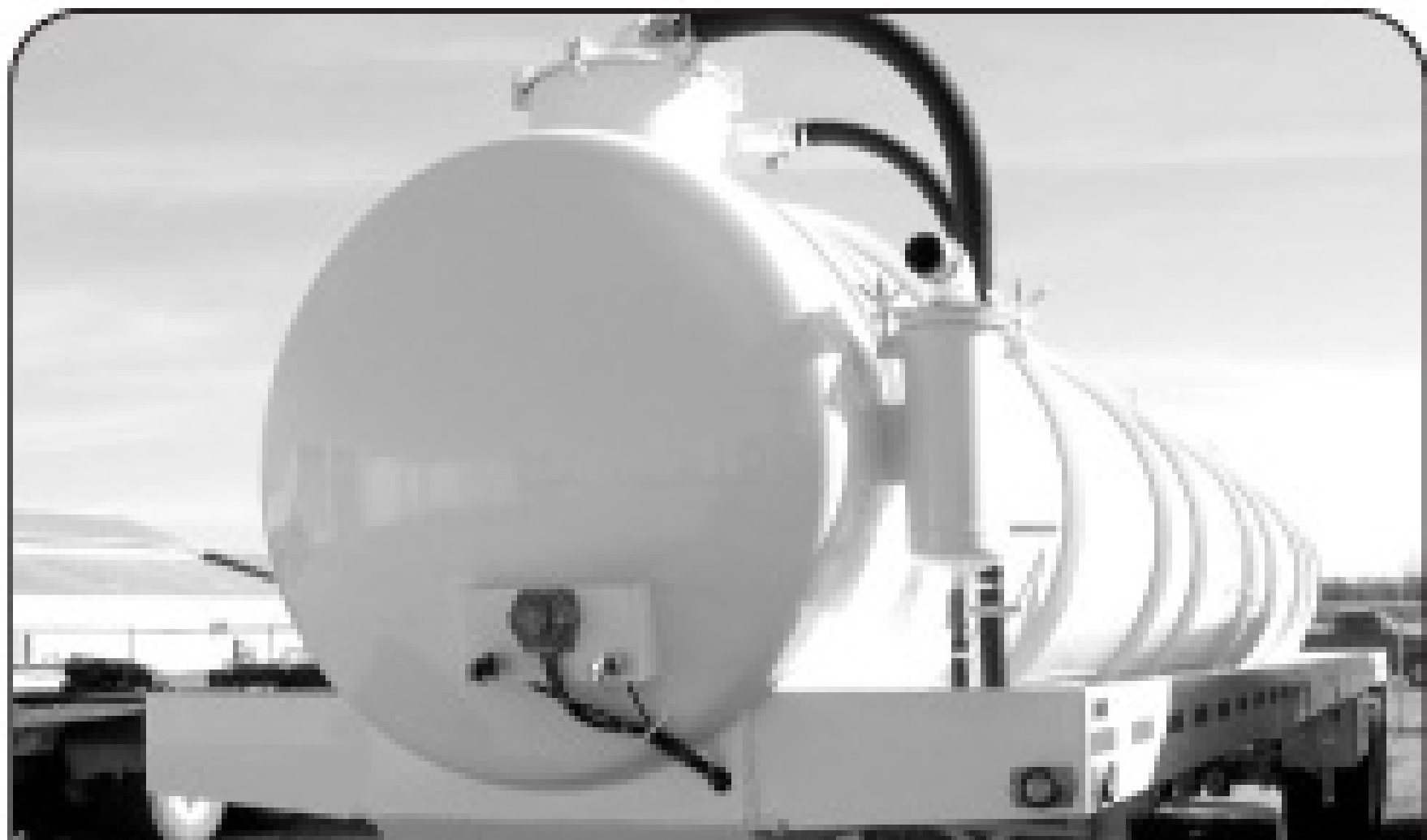

New Fluidmaster 5460 gal. vacuum trailer in stock. Also several used vacuum trailers in stock.



1999 IH 9900, Detroit 60 series (430/500 hp), 10-spd., new Wally 753LN vacuum pump, new 3000 gallon vacuum tank.



1989 Chevrolet C70, 8.2 ltr. diesel, 5+2 air brakes, double frame, MEC 5000 vacuum pump, 1500 gallon vacuum tank.

CALL US BEFORE YOU BUY!



Booth 5211, 5213, 6211

MID CONTINENT TRUCK SALES

manufactures and stocks all necessary components to complete your vacuum system. Whether it's pumps, valves, moisture traps, oil catch mufflers, pump frames, etc.



LET US QUOTE YOUR NEXT VACUUM TANK!

Kerr
Pumps

Since 1946

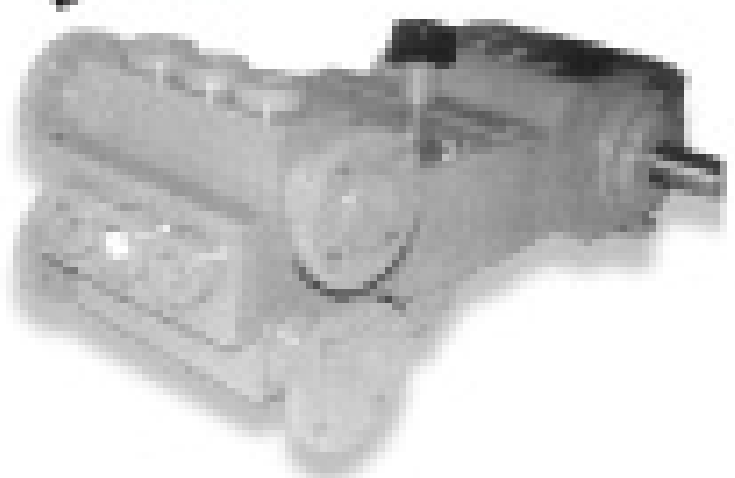

Masport

NVE

AUTHORIZED DISTRIBUTOR



vallenstein
vacuum pumps

BOWIE



FLUID AND SLURRY
PUMPS

WE CARRY MOST BRANDS OF VACUUM PUMPS AND PARTS!



WE WILL BUILD TOILET UNITS TO YOUR SPECS!

Call DAVE PERRY for TRUCK quotations and CHUCK RODGERS for TANK quotations.

435 GALLON VACUUM TANK



- 1/4" Aluminum Construction
- Conde Super 6 Pressure Vac Pump with 5.5 hp Honda Electric Start
- 12 Volt Water Pump
- 300 Waste/135 Fresh
- 25' Hose and Wand
- 2" Sight Eyes in Waste
- Sight Tube on Fresh Water
- Completely Self-Contained
- Ready to Work

OTHER SIZES AVAILABLE

Robinson Septic Service Inc.

125 Rockrimmon Dr., Bellefonte, PA 16823 • f: 814.353.0263 • email: honeydippers@aol.com
1.800.252.3848 • www.robinsonsepticsevice.com



"Duel Power Lid"

Plugs, Lids & Adaptor Rings

Sizes Available: **18", 24", 30" & 36"**

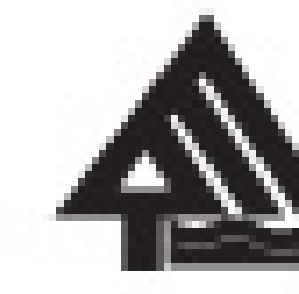

Fergus Power Products
 Providing "Environmental Products"

The Company who maintains a pulse on the environment!

Toll Free **1-800-243-7584**
 E-mail **fpproducts@prtcl.com**

One Complete Package

pumper.com	eq-mag.com
promonthly.com	pumpershow.com
onsiteinstaller.com	pumpertrader.com
mswmag.com	septicyellowpages.com
cleaner.com	sewerpages.com

Cole Publishing | 1.800.257.7222 | 715.546.3346

Aluminum Vacuum Tank Trucks Septic & Restroom Service

Ask about 'Factory Direct' IN STOCK Units.

2500 Gallon Septic Tank
 Masport HXL15 - 350 CFM,
 6" discharge, (2) aluminum cabinets.
2008 Ford 750 33,000 GVW,
 260 HP Cummins, 6 speed,
 air brakes.

\$85,977
 Lease from **\$1719 mo.**



2008 Hino Model 338
 260 HP 6 spd. trans., air brakes
2000 Gallon Tank
 Masport HXL4, dual service,
 wash down, Tow package
 Toilet carrier.

\$78,975
 F.O.B. Kansas City
 Lease from **\$1579 mo.**



TRS INDUSTRIES, INC.
 www.trstruck.com

Contact: Stan Eacobellis
 Toll-free: 877-741-6936
 Direct: 760-741-6936 Fax: 760-746-6767
 651 West 5th Ave., Escondido, CA 92025



Extend Your Hand February 25-28



15,000
NETWORKING OPPORTUNITIES EXIST
 www.pumpershow.com • **800.257.7222**



WASTE OIL RECOVERY TRUCKS

1500-5000 Gallon Cap. • Non Code In Steel • Code Available In Stainless And Aluminum



VACUUM TRUCKS



1000-4000 Gallon Cap. • Non Code In Steel • Code Available In Aluminum

OTHER PRODUCTS AVAILABLE: Fuel • Fuel/Lube • Waste Water Tanks Aluminum



435 S. 59TH AVE. #110 - PHOENIX, ARIZONA 85043

TEL: 602-233-3713 • 1-877-TWI-TRKS • FAX: 602-233-0550 • WWW.TRUCKWORKSINC.COM



WEST-MARK

www.west-mark.com

jhurst@west-mark.com

1-800-692-5844

ASK FOR JEFF HURST

**SEPTIC
GREASE
PORTABLE RESTROOM
TRUCK TANKS**

- FORD
- CHEVY
- ISUZU
- PETERBILT
- INTERNATIONAL
- FREIGHTLINER
- KENWORTH



2009 International 4300, 33,000gvw
 230 HP Diesel engine
 Automatic transmission
 2500 gallon aluminum tank
 Masport HXLW400 pumping system
\$87,572.00 plus delivery



2009 Ford F-550 19,000 GVW (Short 84" CA)
 325 HP Diesel, Auto. Trans. AC AM/FM
 1250 Gallon (350/900) Aluminum Tank
 Marport HXL4 and Burks DC10 pump
\$68,325.00 plus delivery

**Three California locations
 to serve your equipment
 purchase and service needs**



See us at
16014 & 17015

ADVERTISING

SANITATION POSTCARDS & BUSINESS CARD MAGNETS:

Remind your customers and prospects with color postcards and magnets. Economical marketing tools. Tradeshow handouts as well. Call Toll Free 888-334-4553. Visit www.postcardprinting.com. (PBM)

BUCKET MACHINES

For Sale – BUCKET MACHINES: Are extremely effective in sewers that have high water flows which makes jetting ineffective. Clean several sections without blocking traffic flow. Our primary cable drums have a standard capacity of up to 1000 ft. of 1/2" (300 M. of 13mm) steel wire tow cable and have positive clutches designed for manual operation with a positive locking safety handle that is easily engaged & disengaged. PRICE: \$17,500 FOR THE SET COMPLETE. Serious inquiries only please. Contact Chris @ 602-237-0292. (PT12)

BUSINESSES

Well established portable restroom business located in Massachusetts. Includes 7 pumper trucks, 1000+ portable restrooms including handicap, deluxe, trailered VIP units, as well as hand washing stations, urinals, and trailers. Established client base with over 75% of units out on rental at this time. Serious inquiries only directed to Juan.acc@comcast.com. (PT112)

PORTABLE TOILET BUSINESS located in Albany, NY. 600+ units, 3 service trucks, 2 P&D trucks. 20 years family built business. Excellent growth potential. Call Stanley @ 518-441-7222. (CPT112)

FOR SALE: Established company in Florida specializing in the following services: onsite septic installation service & repair, septic pumping & cleaning, portable chemical toilet service. Turnkey operation! Equipment, trucks, accounts. Serious inquiries only. Call TLS 1-352-428-5939. (PBM)

BUSINESSES

FOR SALE: Established 15 years, septic pumping business in Eastern Massachusetts. Excellent reputation, 3000+ client list includes residential and commercial customers. Solid income, excellent growth potential. In the midst of busy season now. Sale of business includes a 1995 Ford L-9000 vacuum truck with 330 hp Cummins engine, 3600 gallon tank, 4 years new. Serious inquiries only @ masepticco4sale@gmail.com. (CPT112)

Arizona pumping company with onsite treatment plant, established 1947. Owners cash flow for first six months of 2008 is \$97,414. Asking \$300,000. Call Scott, WCI Brokers 623-824-4355. (P12C01)

Long Island, New York: For Sale: Casspool, Septic, Sewer and Drain Cleaning Company For Sale. 2 pump trucks, 2 porta-pottie trucks (service and delivery). Quality workmanship, has established 3000+ loyal customer base. Great opportunity for right person. Jump in on busy season! Money maker! Debt free! Office/shop/yard also available. Call for more information. 631-472-0677. (PBM)

BUSINESSES WANTED: Septic pumping, grease trap, drain cleaning and other ancillary businesses wanted. We are buying well run businesses in New England, Mid-Atlantic and Florida. All opportunities will be given proper consideration. Confidentiality ensured. Will move quickly for the right opportunity. Serious inquiries only. Please contact Richard Bedard @ Blue Water, 617-326-3344 or rbedard@bwseptic.com. (CPBM)

FOR SALE: Full service septic pumping, grease trap pumping and drain cleaning business on the western slope of Colorado. Business established in 1993 with large established loyal customer base and excellent reputation. Two 2000 gallon vacuum tank trucks (2005 Int. and 1989 Ford with hydraulic hoist), one 300 gallon vac-tank on 1-ton for small grease traps and 1 service truck complete with sewer cleaning and repair tools. All serious inquiries will be given proper consideration. Please contact us at 970-249-1816 or email terck@wildblue.net. (PBM)

BUSINESSES

FOR SALE: Sunny South Florida. Full service septic tank business established 20 years. Great potential; great records. Owner retiring. Call Chris 305-297-2171. (P112)

FOR SALE: Well established septic pumping and portable toilet business located in Challis, Idaho. 160 toilets, 12 handwashers, 5 trucks, trailers, spare parts, good cash flow, average gross \$200,000, one man operation and still have time to fish & hunt! Call 208-879-2800. (P12)

FOR SALE: Septic and Portable Toilet Business located in White Mountains, Arizona. 150 toilets, 2 ADAs, 3 trucks. For more info, respond to: 11448 East Monte Ave., Mesa, AZ 85209. (PBM)

BUSINESS OPPORTUNITIES

National Grease Recycling Inc. Let us teach you how to recycle restaurant's waste fryer grease and oil (yellow grease) only. **No trap grease.** Big \$. Over 30 yrs. experience. Will guide you through complete process from collection to processing to marketing to end users. Don't lose your trap business to competitors that offer both services. Call for information. Dewey Walker. 813-752-9535 or 813-758-2552. (PBM)

Attention PolyJohn Owners: Receive a **free CD-Rom** of our products to use in your company marketing efforts. Ask your PolyJohn business coach in your area to send you this material today. 1-800-292-1305 Kell. (PBM)

BIODIESEL PROCESSOR, turnkey business opportunity, onsite training/operation, modular and house in cargo containers, react new or used vegetable. www.stopxon.com. (P12)

ELIZAJ Franchise Opportunity-Nationwide accounts ... Looking for team players who want to be part of the "go to" company for quality portable restroom rentals. Turn key operation. Apply online at www.elizaj.com or call 800-437-1139. (PT1)

BUSINESS OPPORTUNITIES

WWW.ROOTERMAN.COM. Franchises available with low flat fee. New concept. Visit web site or call **1-800-700-8062 x26**. (CPBM)

INVENTION OF A TRASH CAN WITH NO BOTTOM. Can be used for recycling, leaves collection during fall or trash only. Patent pending. Fill the bag and lift the can, not the bag, and save your back. No workmen's compensation to deal with. Will allow licenses. You buy sub-wholesale and sell wholesale. This ad is to see if there is an interest. Production pending. Call 808-479-1876 or email kiscanllc@yahoo.com. (P3)

COMPUTER SOFTWARE

WINTAC is the #1 software for scheduling, CRM, billing, service tracking, accounting, marketing, vehicle management. FREE demo at www.wintacpro.com. 1-800-724-7899. (P102)

Pumper Plus Billing Software: Regularly \$795. Mention this ad in Pumper.com and purchase for only \$595. Pumper Plus is a billing software package from Galaxy Systems, www.galsys.com/pumperdemo.asp, that handles billing for septic pumping and portable toilet service-type companies. Inquire at solutions@galsys.com or call 800-985-3029. (PBM)

DEWATERING

Buy - sell - trade - lease: Filter presses, belt presses, vacuum filters, filter cloth, dewatering bags, tanks, mixers and more! Call Waste Treatment Equipment Specialties at 440-808-8844. www.wescoequip.com. (PBM)

Alar, Model 650, very good cond. Completely automatic with all controls and panels, filters down to 1/2 micron, sludges generated by septic and grease haulers. Reducing BODs, F.O.Gs, TGS, total phosphorus, meters and NH3-N. 770-917-0377. (PBM)

DEWATERING

DeTainer DT30 full stainless steel, cold weather insulation, rolling roof, \$40,500. DeTainer DT30 stainless interior screens, carbon exterior, \$29,950. Muffin Monster grinder w/controls; skid mounted, in-line, \$16,000. DeTainer (2) self tipping hopper units w/stainless interior 3.5-yd., each \$5,000. 21,000 gal. frac tank, CPC, \$26,000. Stacking conveyor for belt press, radial, stainless steel, 18 inches wide, 36 feet long, elecdrive, \$9,500. Pit Hog electric dredge. 1998 Mack spreader truck w/floatation tires and 4,000 gal. Huhn tank, \$40,000. Contact Joe or John 919-938-2955 or joe@atlanticdewatering.com. (PM12)

1989 BDP model E 1 meter belt press with rotary drum thickener, 2 – 500 gallon polymer mixing tanks, infrared heaters, fluorescent lighting, stainless steel flooring with fold out walkways, variable speed controls for sludge pump, rotary drum, polymer pump, and press section. All self contained in a 50' curtain side trailer with air ride, \$140,000 OBO. **Flottweg model 2-73 26" horizontal decanter centrifuge** with 8' gravity belt table, 2 – 500 gallon polymer tanks, infrared heaters, fluorescent lighting, stainless steel flooring with fold out walkways, variable speed controls for sludge pump, gravity table, polymer pump, and centrifuge. All self contained in a 50' curtain side trailer with air ride, \$395,000 OBO. **2005 BDP model 3DP 1 meter belt press** with 8' gravity belt table, 2 – 500 gallon polymer mixing tanks, infrared heaters, fluorescent lighting, stainless steel flooring with foldout walkways, variable speed controls for sludge pump, gravity table, polymer pump, and press section. All self contained in a 48' curtain side trailer with air ride, \$285,000 OBO. Contact Parker Ag Services at 719-775-9870 Ext 223 for Kipp or Ext 233 for Bob. (P12)

DAF, 6X12 F.R.C. All stainless steel w/2 dissolved air pumps. Top paddle and bottom worm drive skimmers removes suspended solids particles and colloidal materials from liquid waste, such as fats, oils, grease, latex, pump and paper fiber. Treating approx. 140 gallons per min. 770-917-0377. (PBM)

PLACE YOUR AD ONLINE AT www.pumper.com – IT'S ALWAYS THERE TO MEET YOUR BUSY SCHEDULE

DEWATERING

2007 21' dewatering box with injector. \$46,000 OBO. Like new condition. Optional 2007 30' gooseneck trailer, additional \$6,000. Contact 405-819-5256 or 405-819-5586. (P12)

Used IDS dewatering box 1 year old. Polymate Polymer unit like new. Inground holding tank pump. 1992 Freightliner roll off truck. Whole package \$50,000. 304-425-5329. (P12)

DRAINFIELD RESTORATION

1997 TERRALIFT, 341 hours, 4' and 6' probes. Excellent condition. \$11,000. 804-492-4826. (CP12)

DRAIN/SEWER CLEANING EQUIPMENT

2000 VAC-CON V350 LHA / 850 on an International 2554 chassis - 110,000 miles; 5 yard debris body; 50 gallons of water; 10' telescopic boom; 3 stage fan/hydrostatic drive; 180 D articulating hose reel; 50 gpm, 3000 psi water pump; variable water flow; debris body flush out; storage box - full width behind the cab. This unit is clean, totally rebuilt, new engine, paint job, etc. \$79,900. Serious inquiries only please. Contact Chris @ 602-237-0292. (P12)

RODDER TRUCK: (Sreco Flexible) 1990 Ford F450 w/123,000 miles, 7.3 L Diesel, auto tran, A/C, sectional rodder. Truck, tires and rodder motor in good condition, needs rodding segments replaced. Check website www.ziamunicipal.com for more information or call 614-419-4579. (CP2)

1980 FORD F600 GAS JETT RODDER FLUSH TRUCK. Operable condition, runs and operates. Needs tank repair. Will sandblast and paint tank (inside and out) for \$1,500. 500' Piranha hose 1" ID 2500 psi QC #04049-1-26040019 Aquatech Ser. 41734-B Part #3364 T large 60 gpm. Price \$2,500. Indianapolis, IN. John Crews 317-435-3934 for questions. (CP1)

DREDGES

Seepex sludge & polymer mixing & pumping unit. 5 years old. Excellent condition. Asking \$20,000 OBO. Call 1-506-672-2100. (PBM)

EXCAVATING EQUIPMENT

FOR SALE: 2004 JCB 214-4WD Backhoe Loader. 414 hours, Powershift transmission, 92" GP bucket, precision controls, extra-dig, 36" bucket, 18'6" dig depth, turbo engine with 92HP. Original owners. Serial #904623. Comes with trailer. \$48,000 OBO. Contact James 561-737-8818. (P12C01)

GREASE TRAP SEPARATOR TANK

Grease Trap Separator Tank for Truck. SAVE MONEY, fuel, dump fees and wages. Revolutionary design. Call 239-731-2587 for info & free DVD. (P12)

HAZARDOUS WASTE UNITS

ATTENTION: Fleet of Mack vacuum waste oil trucks for sale/trade by owner. Assorted size MC312 aluminum vacuum tanks. 417-619-5111. (PBM)

2009 Sterling LT9500 triaxle with a new Presvac, **Powervac** 3800, 3,250 gallon (US), DOT, wet/dry industrial, vacuum tank loader. (Stock #13336) **www.VacuumSalesInc.com, (888) VAC-UNIT (822-8648).** (PBM)

1986 Polar 5,000 gallon 316 stainless steel MC 307/312 vacuum trailer with hyd. vacuum pump drive. Spring suspension. In excellent condition. Must see. KLM Companies 617-909-9044. (P12)

NEW Presvac 5500 gallon c/s DOT certified vacuum tank unit, self-contained. **In stock!** (Stock #13325B) **www.VacuumSalesInc.com, (888) VAC-UNIT (822-8648).** (PBM)

2009 Freightliner 120 steerable triaxle with new Presvac Powervac 3,800 cfm, DOT 412, wet/dry vacuum unit. 3,200 gallon tank with full open rear door with top loading boom. 450 hp MB engine with aluminum wheels and fully loaded. Buy or rent. KLM Companies/KLM Rentals Inc. Call 781-934-5437. (P12)

2000 Kenworth T300 cab and chassis with a Presvac 2010 US gallons, DOT certified vacuum tank. **In stock.** (Stock #4675C) **www.VacuumSalesInc.com, (888) VAC-UNIT (822-8648).** (PBM)

HAZARDOUS WASTE UNITS

2009 Peterbilt 365 tri-axle with a new Presvac, Powervac 3800, 3250 gallon (US), DOT, wet/dry industrial, vacuum tank loader. **In stock!!!** (Stock #13340V) **www.VacuumSalesInc.com, (888) VAC-UNIT (822-8648).** (PBM)

2009 Peterbilt 340s **loaded with every option except with automatics** with a new Presvac 3200 gallon carbon steel, DOT 412 certified, **full open rear door, dump style units.** PVB750 vacuum pumps. (Stock #13335 B&C) **In stock.** **www.VacuumSalesInc.com, (888) VAC-UNIT (822-8648).** (PBM)

JETTERS-TRAILER

Harben 4016 with silent pack, jump jet, antifreeze system, less than 2000 hrs., very good condition, 1999 model. \$14,500. 740-357-1208. (P1)

95' US Jetting 4014-300. Recently sandblasted and repainted, pump rebuilt. Machine looks and works like new. \$12,000. 208-888-9191. (CP1)

Used PipeHunter model 38T44 jetting unit, trailer mounted unit, w/335 poly water tank, 4000 psi @ 25 gpm, 600' hose and attachments. **In Stock!!!** (Stock #4313V) **www.VacuumSalesInc.com, (888) VAC-UNIT (822-8648).** (PBM)

2007 Harben Jetter 4018-DTD E45 Series with jump jet, like new, only 40 hours. Swivel reel and mini reel, \$32,500. 919-278-8450. (CP12)

New PipeHunter Model 38T44 jetting unit, trailer mounted unit, w/335 Poly water tank, 4,000 psi @ 25 gpm, 600' of hose and attachments. **In Stock!!!** (Stock #13317) **www.VacuumSalesInc.com, (888) VAC-UNIT (822-8648).** (PBM)

1993 Sreco model HV2060 trailer jet, 35 gpm, 2000 psi, Myers pump, 500' of 3/4" hose, 600 gal. plastic water tanks. Was a city owned unit. 714-639-8352. www.empireequip.com. (CPBM)

New O'Brien Model 3518-SC jetting unit, trailer mounted unit w/350 poly water tank, 4000 psi @ 18 gpm, 400' of hose and attachments. **In Stock!!!** (Stock #3024V) **www.VacuumSalesInc.com, (888) VAC-UNIT (822-8648).** (PBM)

JETTERS-TRAILER

2 SECA trailer jets. Both have Myers 35 gpm, 2000 psi pumps. New paint on both. Located in Dallas. 972-938-1905. www.empireequip.com. (CPBM)

JETTERS-TRUCK

1986 CHEVY C-65 Cat. Diesel 175K, 5-speed manual split shift. New brakes and tires. Pump-Meyers D-65, 2000 lbs @ 65 GPM. One hour on rebuild. Perkins diesel. 1000 gallon tank. Good hoses and nozzles. Ready to work. \$15,000 (a steal). 770-527-0376. (CMPBM)

1995 VAC-CON MV-311THA, municipally owned, automatic, new 3-stage blower, recent rebuild water pump, wash down gun, hose reel, arrow board strobes, toolbox. \$42,500 OBO. patspump@aol.com. Call 800-359-7867. (CP12)

CHERRY!! 1971 Chevy C50, 350 engine, 5 x 2 transmission, 38,000 original miles, well cared for. Wisconsin engine and Meyers D-65 pump. 1200 psi and 65 gpm. 1,000 gallon tank. 500 ft. of 1" hose and 250 ft. of 1/2" hose. Beautiful working truck, a steal at \$9,000. Call steve @ 419-522-2084, see kimbleseptic.com, or email portapotohio@yahoo.com. (P12)

1988 Ford F800 Sreco jet truck, 65 gpm, 2000 psi, former city truck, 47,300 miles, 1000 gallon water tank, Myers pump. 651-489-5185. (CPBM)

1990 Vactor Model 850 water jet on an International 4500, 65 gpm @ 2000 psi, 1500 gallon water tank. Good running condition. \$9,500. 714-639-8352 or craig@empirepipecleaning.com. (CPBM)

2006 GMC TC6500 cab & chassis truck mounted jetting unit with JET EYE camera system, 3,000 psi @ 50 gpm, 1,000 gallons water, 600' hose, 500 cfm blower, debris tank and attachments. RENT ME!!! (Stock #13234) **www.VacuumSalesInc.com, (888) VAC-UNIT (822-8648).** (PBM)

JET VACS

Monster of a truck! 2005 Vac-Con V311/1300, 10' aluminum telescoping boom, front-mounted hydrostatic drive, 600' x 1" 2500 psi/6250 - 200'. \$215,000. 970-494-1610. (P12)

JET VACS

2003 Vac-Con VPD4216LHA, mounted on Sterling 9501, 16 yard, 800' hose reel, 1500 gal., 85 gpm/3000 psi, hydrostatic blower, clean good running truck. \$149,800. Call 561-718-2736. (PT2)

CAMELS: 2008 Camel 200 DEMO unit, only 8,500 miles+/- Like new with Cat Diesel, Sterling tandem chassis, 10 cy dump, front reel mount, winter circulation and vacuum excavating packages, never titled. 1997 Camel 200 on Ford LT8515 tandem chassis. One owner truck with only 67,000 miles, Cummins 275 Diesel, auto shift, 10 cy dump body and behind the cab reel. 1990 Camel 200 on a Ford LNT 8000 chassis w/a Ford Diesel, auto shift, 10 cy body, front reel and only 42,000 miles, municipal owner. Check website www.ziamunicipal.com for more information or call 614-419-4579. (CP2)

2002 - 1991 Vactor 2100s in stock and ready to work. Models available equipped with either PD or fan style blower, 80 - 60 GPM pumps, mostly fully loaded, ex-municipal units with low hours and miles. Call Joe 312-208-6373. (P12)

1994 Guzzler, Ford LNT8000, 126,250 miles, 275 hp, auto transmission, 9-cy debris tank, 16" Roots blower, Myers water pump, 2000 psi @ 80 gpm, 1500 gal. capacity, 8' extendable boom. Good condition. Asking \$67K OBO. 716-523-6813 after 5:00 pm. (P12)

2005 Vac-Con Mounted on a 2005 International chassis, low hours. Please call Kenny or Darel 904-744-9138, 904-993-5211. (CP12)

1994 remanufactured Vactor 2115, Ford 9000, 9-spd., 100 gpm, 2000 psi pump, 2-stage fan. Many options. Call for list. \$59,000. 440-352-9472; 216-299-1396 Cell. (CP12)

1997 Clean Earth, Ford LNT 8000, 98,575 miles, 275 hp, auto transmission, 4-cy debris tank, 16" Roots blower, Myers water pump, 2000 psi @ 80 gpm, 2000 gal. capacity, 4' extendable boom, rear mount hose reel. Good condition. Asking \$52K OBO. 716-523-6813 after 5:00 pm. (P12)

1998 Vac-Con Model V350THA, 3-stage fan, 50 gpm, 3000 psi pump, 5-yd. debris tank, new white paint. Was city owned. 714-639-8352. www.empireequip.com. (CPBM)

BUY IT - SELL IT - PLACE IT - www.pumper.com - AVAILABLE ANYTIME, ANYWHERE, ANY DAY

JET VACS

2008 Sterling LT7501 with a Vac/All Safe Jet Model AJV1215 1500 water comp, 12-yd. debris body, Roots 824 PD blower, 80 gpm @ 2000 psi jetting system with 600' of 1" hose. Combination vacuum-jetter unit. **In stock - RENT ME!!!** (Stock #0329V) **www.VacuumSalesInc.com, (888) VAC-UNIT (822-8648).** (PBM)

2002 Vactor 2112 on a 2002 Sterling, 80 gpm, 2500 psi, **PD blower**, new white paint. Located in Dallas. 972-938-1905. **www.empireequip.com.** (CPBM)

1998 Vac-Con V312THA on a Ford LT8000, 3-stage fan, 65 gpm, 2000 psi pump, extendible boom, articulating hose reel, 12 yard debris tank, new paint. Was a city owned unit. Located in Dallas. 972-938-1905. **www.empireequip.com.** (CPBM)

1998 Clean Earth, Ford Louisville, 136,900 miles, 275 hp, 10-speed Eaton Fuller, 10-cy debris tank, 27" Roots blower, variable speed Myers pump, 2000 psi @ 80 gpm, 1500 gal. capacity, 8' extendible boom. Also serves as a hydro-excavator. Good condition. Asking \$82K OBO. 716-523-6813 after 5:00 pm. (P12)

Jack Doheny Supplies Inc. offers a full range of late model combo units and DOT industrial vacuum loaders. Call us @ 1-800-3DOHENY. (CPBM)

2000 Vac-Con V350/850 on International 2554 chassis, 109,000 miles, 5-yard debris tank, 3-stage fan, hydrostatic drive, 180 D articulating hose reel, 50 gpm, 3000 psi water pump. \$75,000. Contact Julio Cisneros 623-980-8063. (CPT12)

1998 Vactor 2110 on a Freightliner FL80, 28,213 miles, 2-stage fan, 80 gpm, 2,000 psi pump off system accumulator. Was a city owned unit. Located in Dallas. 972-938-1905. **www.empireequip.com.** (CPBM)

LEASE/ FINANCING

NEW AND USED EQUIPMENT FINANCING. Quality off lease and reconditioned repos available to buy, lease or rent. Competitive rates and flexible terms. **Call Brad @ 610-942-3930.** (PBM)

LEASE/ FINANCING

BSM Financial Group is a nationally recognized finance company. We offer flexible payment schedules for all types of equipment new or used. Trucks, pumps, jettors, portable toilets, and software easily financed. We do first time start-ups, established businesses, and challenged credit. **Call Brett at 877-524-7972 or email brett@bsmfinancialgroup.com.** (PBM)

North Star Commercial Credit: Commercial Loans for Trucks or Equipment. Flexible purchase programs to fit your budget. 21 yrs. in the industry. Contact **Tom Myers - 877-804-2274.** (CPBM)

Grow Your Business Today! Get competitive financing. No payment for 6 months. Seasonal plans! No age restriction. Don't wait. Liberty Capital Group, Inc. 888-798-3976. (PBM)

MISCELLANEOUS

Top quality aerators at wholesale prices. We have replacement units for most name brands and also carry Linear Regenerative Rotary Vane pumps. Flagg Air, Gast, Thomas, FPZ, Secoh, Medo and more. Call a company that understands aerators and aeration systems. Septic Services Inc. 800-536-5564. (CPBM)

JET FORMS FOR SALE. One monolithic, one non-monolithic. \$12,000 for the package. Call 305-872-2033. (P2)

1987 F-700, diesel, 5 speed, 2000 gallon hydraulic lift, fully opening rear end tank, good for hauling & dumping mud, 310 cfm pump, \$6,000. 405-235-8600. (P12)

DISCOUNT ALUMINUM: ARE YOU PAYING TOO MUCH? 1,000 lb. minimum quantity. 5052/5454/5083/5086. .063 - 5.0" thick. All widths. Contact Jayson. 1-888-540-0066. (PBM)

PARTS & COMPONENTS

PARTS & SERVICE for vacuum pumps and vacuum tanks. Vacuum pumps also in stock. 800-909-6909. Ask for Ken or Randy. (PBM)

PORTABLE RESTROOMS

DARK GREEN SATELLITE TUFWAYS, 3-4 years old, good condition, \$125. Call Barb 772-538-9575 (FL) or email bmacw@aol.com. (P12)

Red, white & blue PolyPortable toilets for sale. 150 brand new, \$350 each; 200 1-year-old, \$275 each. Also 5 handicaps & 4 double sink handwash stations available. Please call 352-572-2687. (P12)

100 Satellite units, all sand color. No damage; no graffiti. Pick up in So. Oregon. \$300. 541-882-0045. (P02)

6 Satellite Liberty handicap units, bought new in Aug. and used only for 2 events. Colors are tan, blue and green. Paid over \$1,500 per unit; will sell for \$1,250 per unit or \$7,000 for all of them. 660-438-6550. In Missouri. (PT12)

154 Armal green portable restrooms for sale. Breakdown is as follows: 104 new unassembled in box; 15 new and assembled; 35 used (very limited use). Also available: 8 250-gallon waste tanks and 8 90-gallon fresh water tanks. Please contact Kevin Meadows at 610-637-4693. (P12)

SEVEN PolyJohn, portable 2 station sinks, \$300 each. 50 Olympia Fiberglass poly-units, blue with white top, excellent condition! These have fiberglass tank and floor with poly sides and top, \$300 each. Call steve @ 419-522-2084 or portapotohio@yahoo.com, see portapotohio.com. (P12)

500 Olympic Fiberglass units for sale. Units are older construction grade. Located in Albuquerque, New Mexico. \$100 each. Call 505-345-3965. (PT12)

Half Units: Good condition, 300 PolyJohn half units and 300 sling units and regular units for sale. Contact Manuel @ 305-970-9837. (P12)

50 tan Hampel portable restrooms; new, never used. Las Vegas. \$450 each or all 50 for \$400 ea. Pictures **www.acoinc.com/classified.** 208-362-3193. (P12)

Used PolyJohn, PolyPortable tan units, plastic skids, average to excellent condition. \$225-\$325 each. Can arrange shipping. Call Bob at 1-352-796-4540. (PBM)

PORTABLE RESTROOMS

Over 600 PolyJohn units 1-2 years old. Starting at \$300 each. Minimum purchase of 26 units. 772-562-4604. kim@reliablepolyjohn.com. (PBM)

MUST SELL: 400 grey PolyJohn PJ-III toilets. All less than 4 yrs. old. Asking \$300 each OBO. All ready to use. Will discount for quantity purchases. FL 941-473-5419 or erin@amberjack-inc.net. (PT01)

Portable Toilets: Poly constructed, molded seat, urinal, latching door. Handicap accessible units available. New and used. CCI/Brian Touey 805-896-3777. (PBM)

PORTABLE RESTROOM TANKS

Single or multiple compartment tanks. Choose mild, stainless, or galvanized steel. Capacities from 100 to 6000 gallons, any diameter. Parts and accessories to build your own and save money. 800-545-0174. **www.tanksandpumps.com.** (PBM)

PORTABLE RESTROOM TRAILERS

1991 Olympic fiberglass 34' trailer. 6 stalls, 3 sinks on women's side, 2 stalls, 5 urinals and 2 sinks on men's side, heat and AC, interior lighting, indoor/outdoor carpet, 1,200 gallon waste tank, vinyl skirting on outside, everything works 100%, excellent condition. \$20,000 firm. See @ portapotohio.com; call 419-522-2084; email: portapotohio@yahoo.com. (P12)

Trailers for sale, separate or together. Must sell, reasonable. View pictures at **www.comfortcoaches.com** Contact: Don 443-867-9883 or dsauer1751@aol.com. (PT12)

Restroom Trailer - Gold Series: 32', new and used. Women's - 5 stalls, 2 sinks. Men's - 2 stalls, 2 urinals, 2 sinks. CCI/Brian Touey 805-896-3777. (PBM)

New and used **RESTROOM TRAILERS** available immediately. 8 to 34 foot luxury trailers. Comforts of Home Services Inc. 877-382-2935. (PBM)

Restroom Trailer - Platinum Series: 30', new and used. Women's - 4 stalls, 2 sinks. Men's - 2 stalls, 3 urinals, 2 sinks. CCI/Brian Touey 805-896-3777. (PBM)

PORTABLE RESTROOM TRUCKS

1994 International 4700 with a Keith Huber 1,500 carbon steel portable toilet service unit. (Stock #6499V) **www.VacuumSalesInc.com, (888) VAC-UNIT (822-8648).** (PBM)

2001 Isuzu FTR, Crescent tank pumper, 25,900 GVW, 152,000 miles, runs good. New transmission, new tires, 1000 waste, 300 fresh. Will trade for restroom trailer. \$34,850. FSBO. 585-657-1010. (PBM)

1997 Ford Super Duty, 7.3 turbo diesel, 5-spd. manual trans., Lely steel tank 600 waste/250 water, manual PTO, NVE vacuum pump, Burkes water pump, new tires, motor needs work. \$9,500. 757-438-6858. (P12)

1999 Freightliner w/automatic with a Keith Huber 1,000 waste, 500 water, toilet service unit. (Stock #4506V) **www.VacuumSalesInc.com, (888) VAC-UNIT (822-8648).** (PBM)

2000 International Portable Toilet Truck: 2-unit carrier, 750 gal. waste, 250 gal. fresh water, 5-spd., 7.3 diesel motor with 125,000 miles. Located in Maryland. \$12,000. Call Doug at 410-310-5151. (P01)

1999 Mitsubishi 600/225, auto, A/C, diesel, 242,000. Ready for service. \$11,500. Located in PA. 800-433-2070. (P12)

2004 4300 International, 25,500 GVW, DT466, Allison, A/C, air-brakes, 3-compartment aluminum tank (450/1400/250), M-10 Water-cooled pump, spot lights, 2 Burk water pumps for fill and spray down, restroom carrier. Pictures **www.acoinc.com/classified.** Located Phoenix, AZ. \$40,000. 208-362-3193. (P12)

(2) 1994 Ford with Coleman 700 waste, 300 water toilet service units. (Stock #6084V) **www.VacuumSalesInc.com, (888) VAC-UNIT (822-8648).** (PBM)

AVAILABLE NOW - '08 Isuzu NRR Chassis/Model 1100 Crescent Rectangular Vacuum Tank. Tank/chassis currently in Georgia. **REDUCE** fuel costs and **IMPROVE** productivity with the **All-in-One** vehicle (service & pick-up/delivery). Take advantage of 2008 pricing. Call for quote today **Crescent Tank Mfg.** 585-657-4104; **www.crescent-tank.com.** (P12)

PLACE YOUR AD ONLINE AT **www.pumper.com** - IT'S ALWAYS THERE TO MEET YOUR BUSY SCHEDULE

PORTABLE RESTROOM TRUCKS

New 2007 Isuzu NQR with a 1,250 gallon aluminum portable toilet service unit. (Stock #43580V) **www.VacuumSalesInc.com, (888) VAC-UNIT (822-8648).** (PBM)

Aluminum Portable Restroom Tankers: '02 F-650, 158K, \$35,500; '02 Isuzu, 248K, \$29,150; '02 Inter., 206K, \$31,450; '02 Inter., 154K, \$32,450; '03 Inter., 236K, \$43,500; '03 Inter., 196K, \$44,000. Masport pumps, pressure cleaners, 500 clean, 1500 waste. Contact Manuel @ 305-970-9837. (P12)

Dreaming of a Crescent Rectangular Vacuum Tank? And you have an existing chassis... Crescent Tank Mfg. will up-fit or ship to you tank only. Call to get tank only quote. **Crescent Tank Mfg.** 585-657-4104; **www.crescent-tank.com.** (P12)

1989 Ford LNT 9000, 52000 GVW, 300 Cummins, 9-spd., A/C, PS, air brakes, 3600 gallon tank, Masport water-cooled pump, 21" manway, 26" rear manway, 6" dump. Tank and cab white. Engine overhauled 695 miles since. Price is \$27,000. Located in Las Vegas, NV. Pictures at **www.acoinc.com/classified.** Call 208-362-3193. (P12)

2004 Ford F550 Super Duty diesel pump truck. White with gray interior, Best built with a 1050 gallon stainless steel tank, PTO driven Masport pump, 75,000 miles. Perfectly maintained by Gabrielli Ford in Jamaica, NY. Wholesale price of \$29,500. 800-634-2085. (PT01)

1998 International 4700 with a 1,500 US gallon, 2-compartment (1100/400 split), carbon steel, portable toilet service unit. (Stock #8734C) **www.VacuumSalesInc.com, (888) VAC-UNIT (822-8648).** (PBM)

2000 Isuzu NPR with Workmate Model 750, 500 waste, 250 water, with Masport pump and Masport odor control. Good rubber, 227,000 miles. Engine has 150,000 miles. Priced to sell. \$14,900. Call Frank King 978-452-7750. (PBM)

2002 International Pumper Truck: 4700 series, DT466, automatic, air brakes, 1200 gallon waste, 300 gallon fresh water, Masport 75 pump. CCI/Brian Touey 805-896-3777. (PBM)

PORTABLE RESTROOM TRUCKS

Used Crescent Tank/Chassis (GMC & Isuzu). Available NOW! Call **Crescent Tank Mfg.** for more details 585-647-4104; **www.crescent-tank.com.** (P12)

New 700 US gallon 2-compartment (450/250 split), carbon steel, portable toilet service unit. (Stock #13238V) **www.VacuumSalesInc.com, (888) VAC-UNIT (822-8648).** (PBM)

2008 Ford, 49,000 miles, \$45,000. 2007 C5500 Chevrolet, miles in 40s with aluminum and steel tanks. Still under warranty. Slide-ins 600/200, \$10,000. Portable toilet transport trailers: 8, 10, 12, 14, 16, 20 haulers. New portable toilet trucks and new and used septic trucks. We stand behind everything we sell. Lane's Vacuum Tank Inc. 1-800-592-3308. (PBM)

1999 Isuzu FTR, 190 hp, 6 cyl. diesel, 25,900 GVW, new Allison auto with 2-yr. warranty, Jay's Inc. 1,300 gallon 800/500 split, National 190 cfm vac. pump, Burks DC-10 wash down pump, heated dump valve, heated bucket fill, heated water pump, 60' hose reel, 2-unit toilet carrier, and more. 123,800 miles. \$35,000. Call Dale 708-878-4391. Located in Illinois. (PBM)

POSITIONS AVAILABLE

Russell Reid, a regional leader in wastewater management services is seeking a Sales Manager to manage our outside sales team of Account Executives. We seek candidates with proven success in sales force management and development, strong selling skills and the ability to manage a remote staff. Candidate will also possess strong computer skills, including Microsoft Office, and strong written and verbal communication skills. Industry experience and knowledge of salesforce.com a strong plus. For immediate consideration, please submit resume with salary requirements to: Russell Reid Company, 200 Smith Street, Keasbey, NJ 08832. Fax: 732 225-1738; **hr@russellreid.com.** (P12)

New Jersey based industrial cleaning company has two job openings. Looking for experienced sales person and a safety/operational manager. Call Mike at 974-466-3030 or fax resume to 973-466-3040, **michael@adlertankrentals.com.** (P2)

POSITIONS AVAILABLE

Pipeline Investigations Inc., a Baltimore, Maryland firm, is seeking qualified persons to operate jet vac trucks, mainline CCTV cameras, and/or lateral push cameras. Experience with Ferro Mag locators and sondes a plus. Salaries negotiable based upon experience. Fax resume or personal info. to 410-242-1038 or email **fleetbarnes@pipelineinvestigations.com.** (CP12)

PUMPS-SUBMERSIBLE

Wholesaler for Hydromatic, Zoeller, Myers, Liberty and ABS pumps. We also supply Grinder pumps and basins. Will help you size them. Septic Services Inc. 800-536-5564. (CPBM)

PUMPS-VACUUM

KingVac, Keith Huber, 1993 Ford L8000. New pump, new cyclone, belt driven. Good shape, ready to work! 601-483-2528. (P12)

Vacuum Pumps - New, used, or rebuilt. 30 to 900 cfm. All major brands; air, water, or fan cooled. Rebuild specialists - rebuilt PB, M3, M10, and others available. 800-545-0174. **www.tanksandpumps.com.** (PBM)

Need a vacuum pump for your portable pumper? Try our new 30 cfm, 12 volt system. Less noise, no fuel. Automatic oiling, cheaper than a gas engine. 800-545-0174. **www.tanksandpumps.com.** (PBM)

Complete line of Moro, Conde and engine-driven, stand-alone pump systems, DC10 washdown pump. Call us for any of your vacuum truck parts from shut-off valves, primary and secondary valves, hoses, vacuum pumps and drive systems. Septic Services Inc. 800-536-5564. (CPBM)

New **Masport** and **Jurop** vacuum pumps. Compare our price before you buy. W-K Machine & Supply Co. Call 1-800-633-8947. Distributor. (PBM)

RENTAL EQUIPMENT

Liquid vacs, wet/dry industrial vacs, combination jetter/vacs, vacuum street sweeper & catch basin cleaner, truck & trailer mounted jettors. All available for daily, weekly, monthly, and yearly rentals. **VSI Rentals, LLC, (888)VAC-UNIT (822-8648) www.vsirentalsllc.com.** (PBM)

ROLL-OFF TRAILERS/TRUCKS

1999 Benlee (2) Two container roll off trailer. 75,000 hoist with alum. Budds. Great condition Just painted. \$29,500. KLM Companies. Ph: 617-909-9044. (P12)

1993 Galbreath AC416 single container roll off trailer. Bridge weight design, just sandblasted and painted with aluminum Budds. Good condition. \$17,500. KLM Companies. 617-909-9044. (P12)

SEPTIC TRUCKS

1999 Sterling with a 2,500 US gallon CS dump type unit and pump package. (Stock #2192V) **www.VacuumSalesInc.com, (888) VAC-UNIT (822-8648).** (PBM)

1993 T800 KW septic pumper truck, 861,962 miles, 3000 gallon tank, good tires, Masport pump. \$35,000. Redding, CA. 530-243-0657. (P12)

2002 Presvac 4,000 US gallon C/S tank only. (Stock #6255V) **www.VacuumSalesInc.com, (888) VAC-UNIT (822-8648).** (PBM)

2001 Progress 4,800 US gallon C/S tank only. (Stock #0138C) **www.VacuumSalesInc.com, (888) VAC-UNIT (822-8648).** (PBM)

1990 F-800, 7.8 diesel, 2500 gal. septic hauler, 5 spd. trans., 2 spd. rear end, vac pressure pump. Runs good; pumps good. \$21,500. Call 502-223-8638. Frankfort, KY. 40601. (PT12)

1974 Mack RD685SX triaxle with a 1993 Presvac 4,000 gal. vacuum tank and Masport pump. (Stock #4783C) **www.VacuumSalesInc.com, (888) VAC-UNIT (822-8648).** (PBM)

1992 GMC Topkick, good condition, runs well, A/C, 176,000 miles, 2100 gallon tank, Jurop pump. \$24,500. Chicago area. 815-741-4440. (PBM)

2003 International 7500 with a 3,000 gal. carbon steel vacuum tank unit. (Stock #2319C) **www.VacuumSalesInc.com, (888) VAC-UNIT (822-8648).** (PBM)

2007 Mack CTP713B pump truck. 20 front and 44 rear, 5,363 miles. AM/FM, CD player. 4000 gallon tank with 506 Challenger pump. \$145,000. Kevin 850-333-1651. (PTIM12C01)

SEPTIC TRUCKS

1994 GMC/Volvo N-14, Cummins 350 hp, 52,000 GVWR, 3000 gal. tank with 150 gal. water tank outside, Jurop R260 350 cfm pump. Good truck, works every day. Priced right \$25,000. Call Ted at 225-261-1015. (P12)

2000 Volvo WG64 with a Pikrite 4,000 gal. vacuum tank and a Jurop PNR-102 pump. (Stock #9010C) **www.VacuumSalesInc.com, (888) VAC-UNIT (822-8648).** (PBM)

1983 GMC, 2500 gal. vacuum truck complete. V8 gas, 5-spd./2-spd., PS, AB, 3" Masport vacuum pump, new tires. Factory built. Ready to work, dependable, runs good. \$6,500. Will separate. 845-863-6080. (P12)

2001 International 4900 with a 2,000 gal. vacuum tank and a Wittig RFL100 pump. (Stock #9960C) **www.VacuumSalesInc.com, (888) VAC-UNIT (822-8648).** (PBM)

2003 Mack CV713 cab and chassis with a 3,200 gal. s/s vacuum pressure tank. Masport pump package. **Coming soon!!!** (Stock #3680V) **www.VacuumSalesInc.com, (888) VAC-UNIT (822-8648).** (PBM)

2004 Peterbilt Model 330C, 76,000 mi., 300 Cat, 3600 gal. tank, TSI500 pump, 3", 4", 6" heated valves, air ride, AC, locking differential and tandems. \$82,500 OBO. Call for more info. 715-484-7711. (PBM)

1997 Peterbilt Model 357, CAT 3306 motor, Fuller 8-speed trans., 4200 gal. Transway tank, 800 Transway pump, 220K miles, red. Excellent condition, ready to work. \$55,000. 978-618-6110. (PBM)

1995 Ford L8000. 7-spd. Cummins diesel. New upholstery, new paint Dec. 2007. One owner. Bought new. 3000 gallon tank, 210,000 miles. 850-837-7200. (CP12)

(1) 1989 Mack RD 690 S/A, 2500 gal; (1) 2000 Int. 4900 S/A, 2500 gal.; (1) 1994 Mack DMM T/A, 3500 gal. Excellent front line units. 1-352-796-4540. (PBM)

1994 FL 70 Freightliner, 1620 gal. full door dump, new Masport water cooled pump, new tires, new brakes, 6" air dump, 125-gal. washdown tank. Excellent condition. One owner. 605-286-3359. (P12)

SEPTIC TRUCKS

1989 Ford L8000 with a 3250 US gallon, carbon steel vacuum-pressure tank. **Available now!** (Stock #8474C) **www.VacuumSalesInc.com, (888) VAC-UNIT (822-8648).** (PBM)

2009 Peterbilt 340 with a Presvac 3600 gallon (US) aluminum vacuum tank unit. **In production.** (Stock #13337 A,B,C&D) **www.VacuumSalesInc.com, (888) VAC-UNIT (822-8648).** (PBM)

2001 Intl. DT-466, 7-spd. tandem, new 3600 gal. tank, Masport 350 cfm vacuum pump, 237,000 miles, \$49,000. 2000 Intl., DT-466, auto., new 2300 gal. tank, 350 cfm Masport pump, 147,000 miles, \$44,000. Other new & used toilet & septic trucks available. Everything we sell has warranty. Lane's Vacuum Tank Inc. 1-800-592-3308. (PBM)

Need a tank and truck, any size, any make truck? Let us help you get the best deal. Custom built to your specs. For information and a price quote call 800-545-0174. **www.tanksandpumps.com.** (PBM)

Great Starter Truck! 1985 Ford F-700 370 auto-gas, 1800 gallon waste, 120 gallon fresh, steel tank (7 yrs. old), Jurup pump. \$15,000 OBO. 210-385-1055. (P12)

SHOWER TRAILER

Shower Trailer - Gold Series: 32', new and used. Men and women sides each have 3 private shower stalls with changing area, 1 restroom stall, 1 sink. CC/Brian Touey 805-896-3777. (PBM)

SLIDE-IN UNITS

Slide-In Unit: 2001 Model MFG Lely, 300/110, excellent condition. \$4,500. 541-269-5050. (P1)

SLUDGE APPLICATORS

1987 I.M.E. Super/Jector 3500 gal. vac/pressure tank, 250 hrs. on 3208 Cat re-man. motor. Pearson P88 vac pump, four-knife shank, tires 66x43.00/25 at about 60%. Unit in good condition. **\$31,000 OBO.** Day: 810-560-3268; Evening: 734-878-5228. (PBM)

TANKS

FRAC/Storage tank for sale. 20,000 gallon capacity with steam coils, access stairs, and manway access. \$26,000. Please call for further details. 801-973-7912. (P1)

Vacuum tanks, 100 to 6000 gallons. All options available; hatches, primary, secondary, valves, catwalks, ladders, etc. Everything needed to build your own septic truck. Choose mild, stainless, or galvanized steel. Ask about full open doors. 800-545-0174. **www.tanksandpumps.com.** (PBM)

FOR SALE: 2 fiberglass tanks 14' x 35', approx. 35,000 gals. each, incl. most of the components for a sewage treatment plant to service up to 5000 pop. Produces class A biosolids. Located in Gibsons, B.C., Canada. Can be trucked or barged to new site. Price \$35,000 Can. 1-604-886-7064; 1-604-885-8101 cell. Kelly. (P12)

New 3400 gallon tank, never used, 20' manway bottom, 3' intake, 4' dump, hose trays. \$10,000. Delivery available. 800-721-2774. (PBM)

TANKS

2500 gallon vacuum pressure tank, good condition. \$3,000. 845-863-6080. (P12)

Used 2003 Satellite MD 950 tank in excellent condition. Includes work lites, toolboxes, freshwater pump, 650 waste, 300 fresh, ready to mount on truck. Satellite 2-toilet carrier and Conde 6SS vacuum pump with mounts. Tank came from 2003 Ford 550. \$13,000 OBO. 231-924-8994. (PT12)

TANK TRAILER

2002 Presvac 4,000 US gallon C/S tank only. (Stock #6255V) **www.VacuumSalesInc.com, (888) VAC-UNIT (822-8648).** (PBM)

2001 Progress 4,800 US gallon C/S tank only. (Stock #0138C) **www.VacuumSalesInc.com, (888) VAC-UNIT (822-8648).** (PBM)

New Presvac never mounted 4200 gallon aluminum vacuum tank. Bright finish, complete mounting kit, bumper, lights. \$24,500 OBO. pats pump@aol.com. Call 800-359-7867. (CP12)

NEW Presvac 5500 gallon c/s, DOT certified vacuum tank unit, self-contained. **In stock!** (Stock #13325B) **www.VacuumSalesInc.com, (888) VAC-UNIT (822-8648).** (PBM)

TOOLS

T&T Tools: Probes, Hooks. Probes feature steel shafts with threaded and hardened tips. The insulated **Mighty Probe™** tested to 50,000 volts. **Top Poppers™** open manhole covers easily. Free catalog. **www.TandTools.com.** Phone **800-521-6893.** (CPBM)

Crust Busters - Portable, lightweight machine guaranteed to mix up septic tanks and grease traps! Save time and money! **www.crustbusters.com,** 1-888-878-2296. (PBM)

TOYS

Septic pumper and vacuum die-cast toy trucks in your choice of colors and logos. Several cabs available. Call 877-450-2100 or write to Granite State Collectibles, PO Box 440, New Ipswich, NH 03071. (PBM)

TRAILERS VACUUM/TANKER

Presvac 5500 gal. 316 stainless steel DOT certified vacuum trailer, new Finland 500 vac pump w/complete rebuilt Lister diesel engine. Original tank thickness; no pitting. Excellent overall condition w/new Imron paint. Must see. \$65,000. KLM Companies 617-909-9044. (P12)

1980 Presvac 6,000 gal. trailer, \$10,000 OBO. 1999 Pro vac trailer, 5,000 gal. on board diesel vac pump, \$15,000. Mike. 973-663-2400. (P12)

Used stainless steel Presvac vacuum trailers of various age, condition and capacity from 4,600 to 6,400 gallons. Over a dozen to choose from available for pick-up in Florida, Alabama and Wisconsin. Price depends on capacity and condition. Call 715-546-2680. (CPBM)

VACUUM LOADERS

2009 Sterling LT9500 tri-axle with a new Presvac, **Powervac 3800,** 3,250 gallon US, DOT, wet/dry industrial, vacuum tank loader. (Stock #13336V) **www.VacuumSalesInc.com, (888) VAC-UNIT (822-8648).** (PBM)

2000 Sterling with Cusco Mastervac 3,800 CFM 27" blower with 3,000 gallon tank. Wet/dry unit with full open rear door and Moro vacuum offloading pump. Low miles/hours. Ready for work. KLM Companies 617-909-9044. (P12)

2009 Peterbilt 365 tri-axle with a new Presvac, Powervac 3800, 3250 gallon (US), DOT, wet/dry industrial, vacuum tank loader. **In stock!!!** (Stock #13340V) **www.VacuumSalesInc.com, (888) VAC-UNIT (822-8648).** (PBM)

1992 Ford with Guzzler 4816 with swing out Cyclone 6,000 CFM blower (4 yrs old). Cat engine with Fuller trans. 150,000 miles, 5,000 hours. Runs very good. \$25,500. KLM Companies 617-909-9044. (P12)

1999 International **heavy spec** with **Guzzler ace** wet/dry industrial vacuum loader. 8" top load boom truck is in excellent condition. Blower was reconditioned approximately one year ago. **RENT ME!!!** (Stock #7390V) **www.VacuumSalesInc.com, (888) VAC-UNIT (822-8648).** (PBM)

VANES

Dura Comp 535, high-quality non asbestos vacuum pump vanes. Good to 400°F. Buy factory direct and save. Same day shipment on most models. Jurup, Battioni, Moro, Masport, Fruitland, Demag. Long lasting Dura-Comp 535 pump vanes carry a "Money-back" guarantee. Call us today. Powerflo Products 800-758-4788 or 562-997-0720. (PBM)

American Industrial Components: Our vanes are manufactured from the highest quality laminated materials available and are fabricated to exact tolerances and specifications. 800-272-7557. (PBM)

WANTED

Seeking 1 -2 used high end restroom trailers in good condition for weddings, 24 ft. and larger, cash paid. Call 231-941-7060. (P12)

WANTED: LATE MODEL 2505 TERRAGATOR with chassis only or vacuum tank. Call Ron @ 204-248-2559 or email pictures to info@lagooncleaning.com. (P1C2)

WANTED: 12-yard debris tank for a Vactor PD unit. Call Kenneth @ 972-938-1905. (CPBM)

Water jetting equipment. We rent, sell and repair water blasters. Visit us at: **www.waterjettingequipment.com** or phone 714-259-7700. (CPBM)

WATERBLASTING

2003 NLB 10-150 electric waterblaster, (0) hours on unit - never used. Marathon Motor on skid. If you want brand new this is it. Priced to sell @ \$32,500. KLM Companies, 617-909-9044. (P12)

Wanted to Buy: Vactor 2100s and late model Guzzlers. Cash. Phone 800-336-4369. (CPBM)

NLB 10-250 2000 model year with 1,200 hrs., 250 hp @ 43 gpm. Complete mounted on 1993 International truck with 120,000 miles. Fluid/power end just rebuilt by NLB. In good shape. \$42,500. KLM Companies, 617-909-9044. (P12)

IF YOU ARE USING AN

800 NUMBER

IN YOUR AD, BE SURE IT CAN BE USED IN ALL AREAS NATIONWIDE.

Classifieds Category List - Pumper Magazine
http://www.pumper.com/classifieds/

Looking to **BUY** or **SELL**?
Just Submit Your Classified Ad **ONLINE!**

It's Easy & Secure!

Your ad will be posted on the Pumper Web site within two to three business days after received.

Just go to **www.pumper.com**; click on "Classifieds;" click on "Place a Classified Ad;" fill in the online form.

Only \$1.00 PER WORD (\$20 Min.)

PLACE YOUR AD ONLINE AT **www.pumper.com** - IT'S ALWAYS THERE TO MEET YOUR BUSY SCHEDULE



Classy Truck of the Month

T.A. Lauritsen Septic & Drain Inc.
Montevideo, Minn.

Have It Your Way

Rent - Lease
Lease/Purchase

27' Late Model
Vac Trucks



Spectrum Industrial Services - (205) 664-2000 or Toll Free (888) 739-0838

Owner T.A. Lauritsen keeps this 2007 Kenworth T-800 rig for himself as he serves residential septic and commercial pumping customers in south central Minnesota. Built by Engle Custom Tank Builders of Sauk Center, Minn., the truck is powered by a 370-hp Cummins engine and a 10-speed Eaton-Fuller transmission that smoothly carry a 3,000-gallon waste, 500-gallon freshwater stainless steel tank. Vacuum is provided by a 1,000-cfm Robuschi 65 air-cooled blower, allowing Lauritsen to take on a greater variety of work. A 6-hp Honda engine powers a 2-inch high-pressure pump for cleaning up with freshwater on septic and commercial jobsites. The truck also has a 55-degree hoist, four 4-inch valves and a 6-inch heated air dump valve with back floodlights. Stainless steel is also used for the primary, upper and lower hose trays and toolboxes. The truck features air ride, power windows, polished aluminum wheels, heated mirrors, engine brake and power seats. The cab is painted white and the graphics by Emery Signs are done in tasteful red and white lettering. Lauritsen has an identical 2003 T-800 in his fleet.

Rich Restrooms Manufacturer of Portable Restroom Trailers

Featured floor plan is a 5 station with 410 gallon waste tank. Floor plans from 1 to 12 stations. Call for a quote.

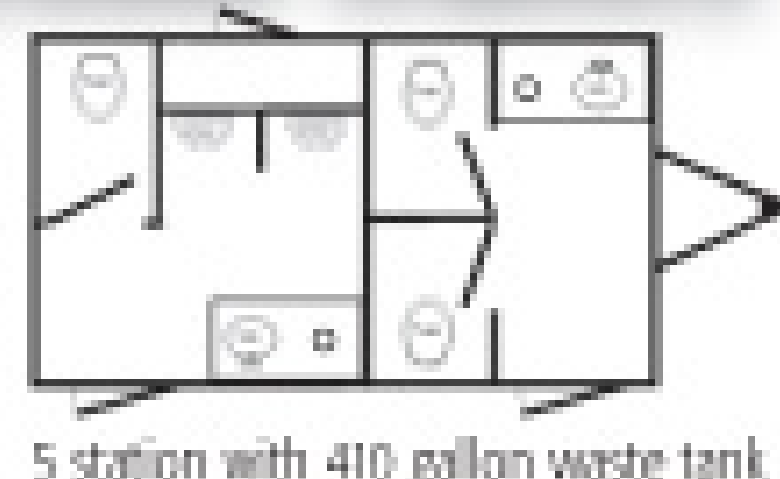

5 station with 410 gallon waste tank.



Rich Restrooms

423 S. Main St. • Topeka, IN 46571
260-593-2279
www.RichRestrooms.com



Show us yours!

Got a truck with real WOW appeal? Show it off to Pumper readers — and to the whole world through www.pumper.com!

Send photos of your truck after it has been lettered with your company name, and please pose the owner(s) with the truck. Any industry-related truck is acceptable. Please limit your submission to one truck only.

Your submission must include your name, company name, mailing address, phone number, and details about the truck, including tank size, cab/chassis information, pump information, the company that built the truck, and any other details you consider important. In particular, tell us what features of the truck help make your work life more efficient and more profitable. E-mail your materials to editor@pumper.com or mail to Editor, Pumper, P.O. Box 220, Three Lakes WI 54562. We look forward to hearing from you!

Marketplace Advertising



CONFINED SPACE ENTRY PACKAGE
ONLY \$3,195

The best package on the market includes:

- 4-Gas Air Monitor (3 Year Sensor Warranty)
- 7' Tripod
- 3-Way Fall Protection
- Work Winch
- Full Body Harness



Add a Blower with 15' of duct for only \$300!
Add a 5 Minute Escape Respirator for only \$500.

- Other Equipment Available
- Sewer Maintenance Tools
 - Magnetic Lid Lifters
 - Camera Systems
 - Smoke & Dye Testing Items
 - Blowers / Ventilators
 - Vacuum Pumps and Acc.
 - Aluminum Folding Ladders
 - PPE
 - High Pressure Water Jetters

MTECH 800.362.0240
www.mtechcompany.com

EASILY MOVE RESTROOMS

- ✓ Aluminum Frame
- ✓ Ships UPS
- ✓ Carry ADA's
- ✓ Models starting at \$380



Available with 2, 4, 6 or even 8 wheels and your choice of air or solid foam tires.

Super Mongo Mover®

DA
Deal Assoc. Inc.

www.dealassoc.com
866.599.3325

COMBAT GREASE

Choose Your Weapon
(Liquid, Dry, Freeze-Dried)



Booth 3045

Drain Line, Greasetrap,
Septic System Maintenance

BIO¹

A COMPLETE ARSENAL FOR
DRAINLINE REMEDIATION

Formulated Proudly
in Partnership with

1-800-951-4246

VISIT OUR BRAND NEW WEBSITE
WWW.ONEBIOTECHNOLOGY.COM

Drain Snake



\$329
Free Freight

Jetter Package



\$1,499
Free Freight

Sewer Camera



\$1,095
Free Freight

COMPLETE DETAILS AT
www.AmazingMachinery.com
1-800-504-7435

T&T Tools

800-521-6893

800-521-3260 FAX

E-mail sales@tandttools.com • www.tandttools.com

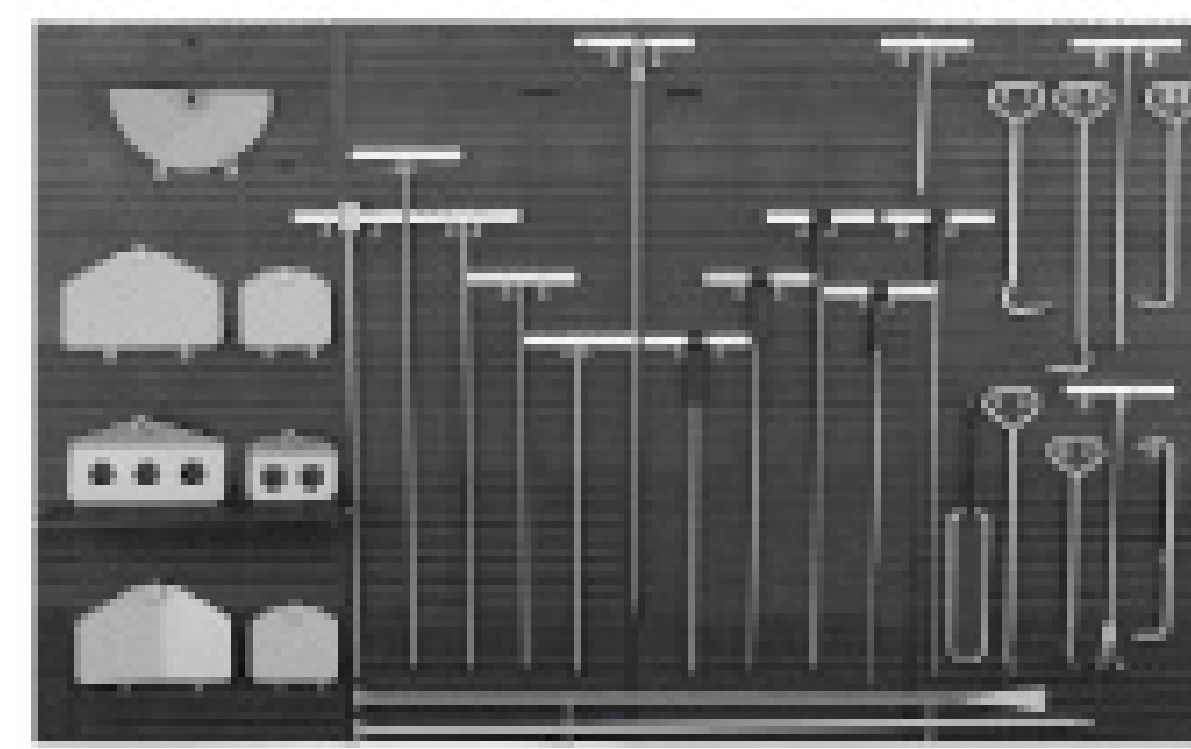

Mighty Probe™
Sludge Hoe™
(insulated)
Sludge Spud™
Manhole Hook™
Tommy Hook™
Striking Head™



Handy Hook™
Water Probe™
Curved Spud™
Top Popper™
Ground Buster™
Smart Stick™
(standard)

www.tandttools.com



Major Credit Cards Accepted!

\$35 PER DOZEN
\$189 FOR 6 DOZEN

- 14" Gauntlet
- Plastic Coated
- Jersey Liner
- Sandpaper Finish Grip
- 1 Size Fits All

Make checks payable to: ADVANCE GLOVE CO.
Please include UPS shipping address.

ADVANCE GLOVE & SAFETY CO.
PO. BOX 149 • LENOX, MI 48449
TOLL-FREE: 1.800.323.1223

WWW.ROOTERMAN.COM



Franchises available with low, flat fee
New concept. Call 1-800-700-8062.
FRANCHISE PACKAGE \$7,950.

Mobile Dewatering Service



Municipal & Industrial Sludge
Digesters, Lagoons,
Ponds, etc.

- Double Belt Filter Press
- Up to 25% Drier Cake
- Professionally Staffed
- US & Canada

Fluid Technology, Inc.
P.O. Box 937, Oxford, OH 45056
Phone: 513-981-7808
E-mail: sales@fluidtechinc.net
Web site: www.fluidtechinc.net

Waterblaster Rentals

Houston, Texas



Boatman Industries

1K to 50K psi
60 hp to 1000 hp
Waterblasters & Accessories
Used Equipment Sales



713-641-6006
www.boatmanind.com



ENVIRONMENTAL EXPO
Louisville '09
YOUR PLACE. YOUR TIME.

FEB. 25-28

ONSITE installer

Dig into our pages.

Each issue shows you:

- New technologies to help you win jobs and earn more profit.
- Tips to boost machine performance and drive out costs.
- Money-saving deals on supplies and equipment.
- And much more.

Best of all, you'll learn from other successful business owners — how they did it, and how you can, too.

FREE Subscription — sign up today!

800.257.7222
www.onsiteinstaller.com

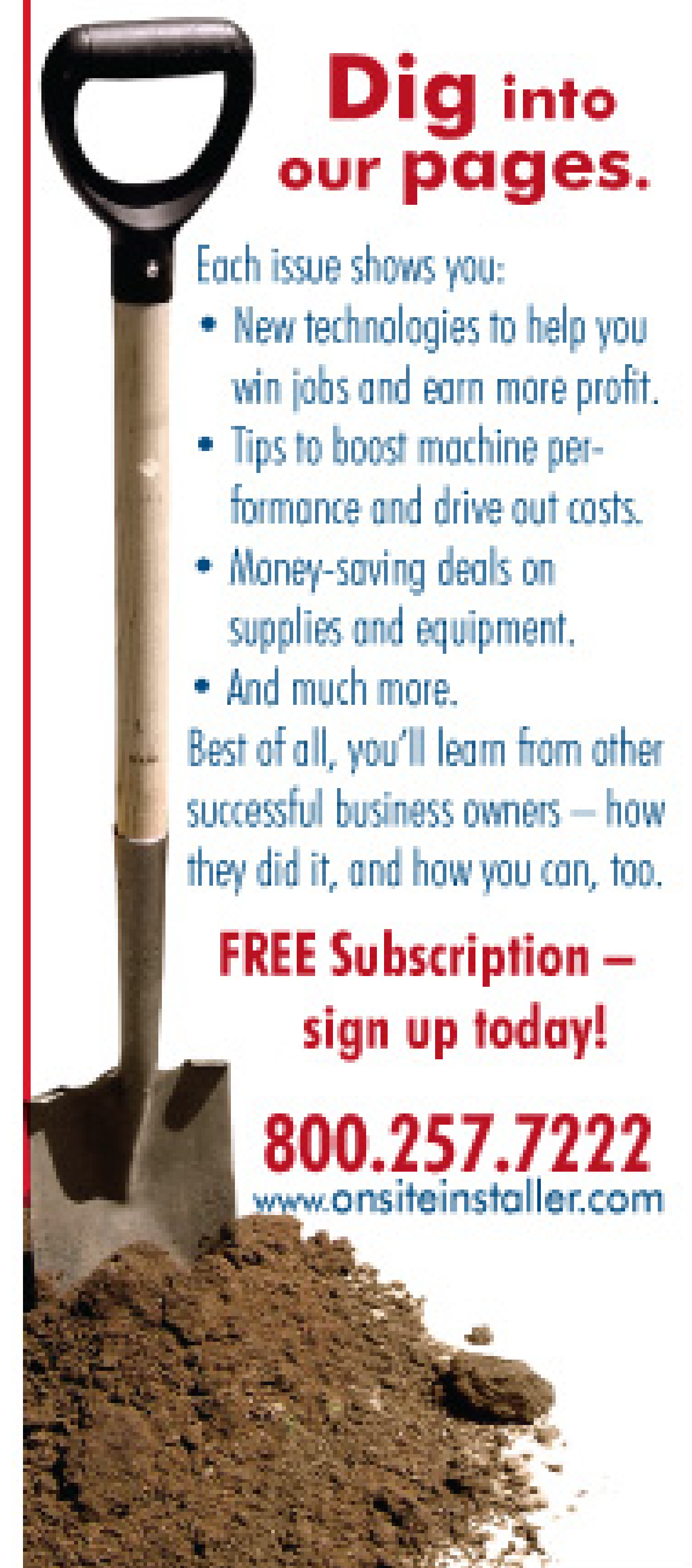

TrakMats®

Ground Cover Mats



- Stop Ruts, Damaged Lawns or Weather Delays.
- Stop Using Heavy, Wet, Rotten, Broken, Slippery Plywood
- Hand Cut-Outs for Lifting

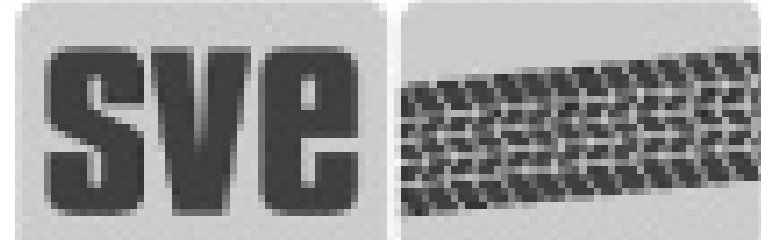

PORTABLE ROADWAY SYSTEMS, INC.

800.762.8267

www.trakmats.com sales@trakmats.com

DISCOUNT ALUMINUM

SHEET, COIL, PLATE

3003/5052/
5454/5083/5086
AND MORE

20 MILLION
POUND INVENTORY

ARE YOU PAYING
TOO MUCH?

1-888-540-0066
ASK FOR JAYSON

FAX:
440-286-2229

E-MAIL:
captaluminum@msn.com

ALUMINUM Vacuum Tanks

ALUMATANK

progresstank.com

PORTAVAC

Septic & Restroom Service

PIT HOG PUMPS WASTE

LWT manufactures
manned and remote
controlled lagoon
dredges and pumps.
Rental dredges also
available.



LWT LIQUID WASTE
TECHNOLOGY.

1750 Madison Ave., New Richmond, WI 54017
www.lwtpithog.com / 1-800-243-1406

MAKE BIODIESEL FOR \$1/Gallon
THE BIOPRO TURNS GREASE TO FUEL
RUNS IN ANY DIESEL ENGINE
BETTER FOR THE ENVIRONMENT
BETTER FOR YOUR ENGINE AND
BETTER FOR YOUR WALLET.

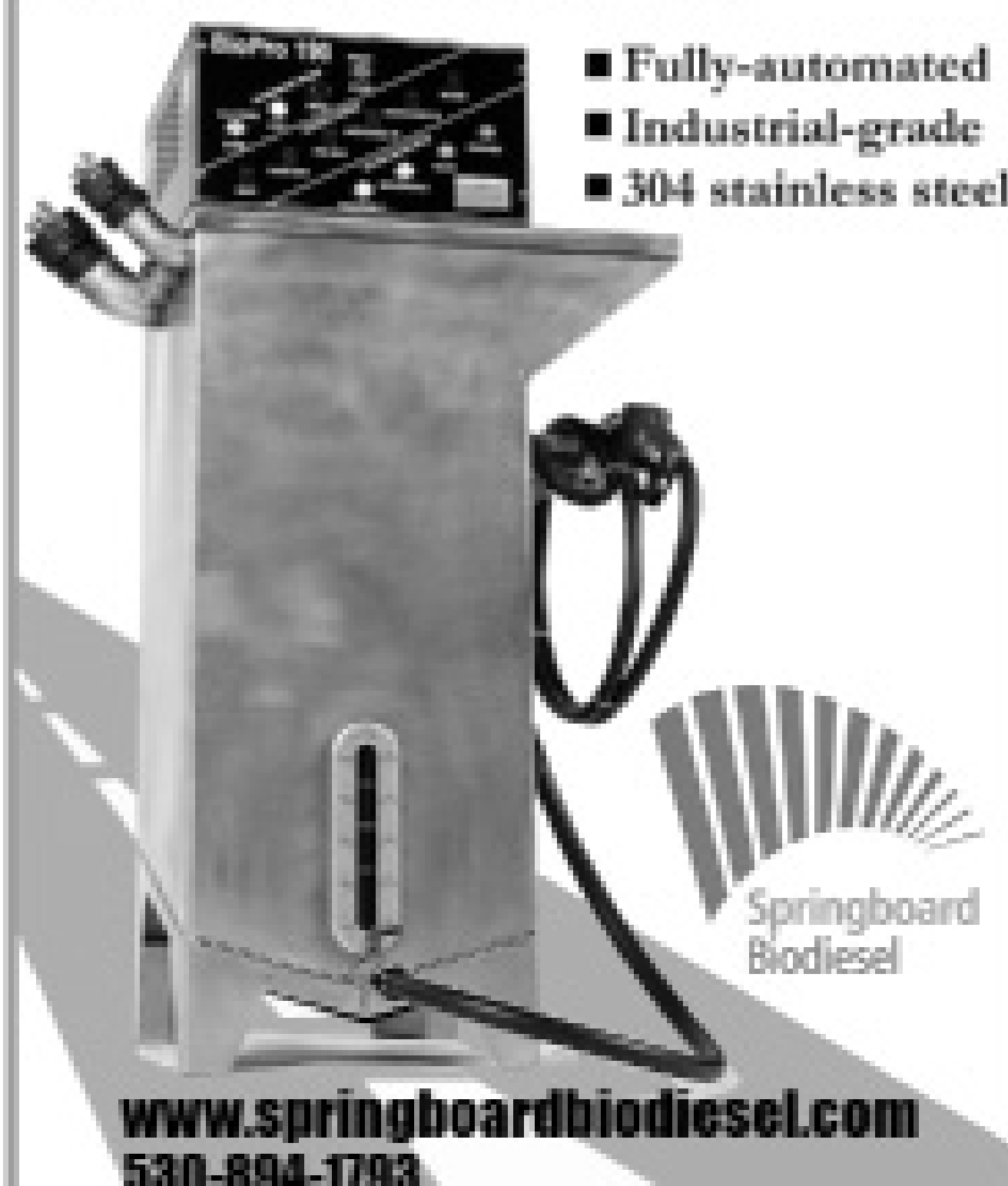

- Fully-automated
- Industrial-grade
- 304 stainless steel

Springboard
Biodiesel

www.springboardbiodiesel.com
530-894-1793

SOIL SHAKER™ 2000

Drainfield Restoration

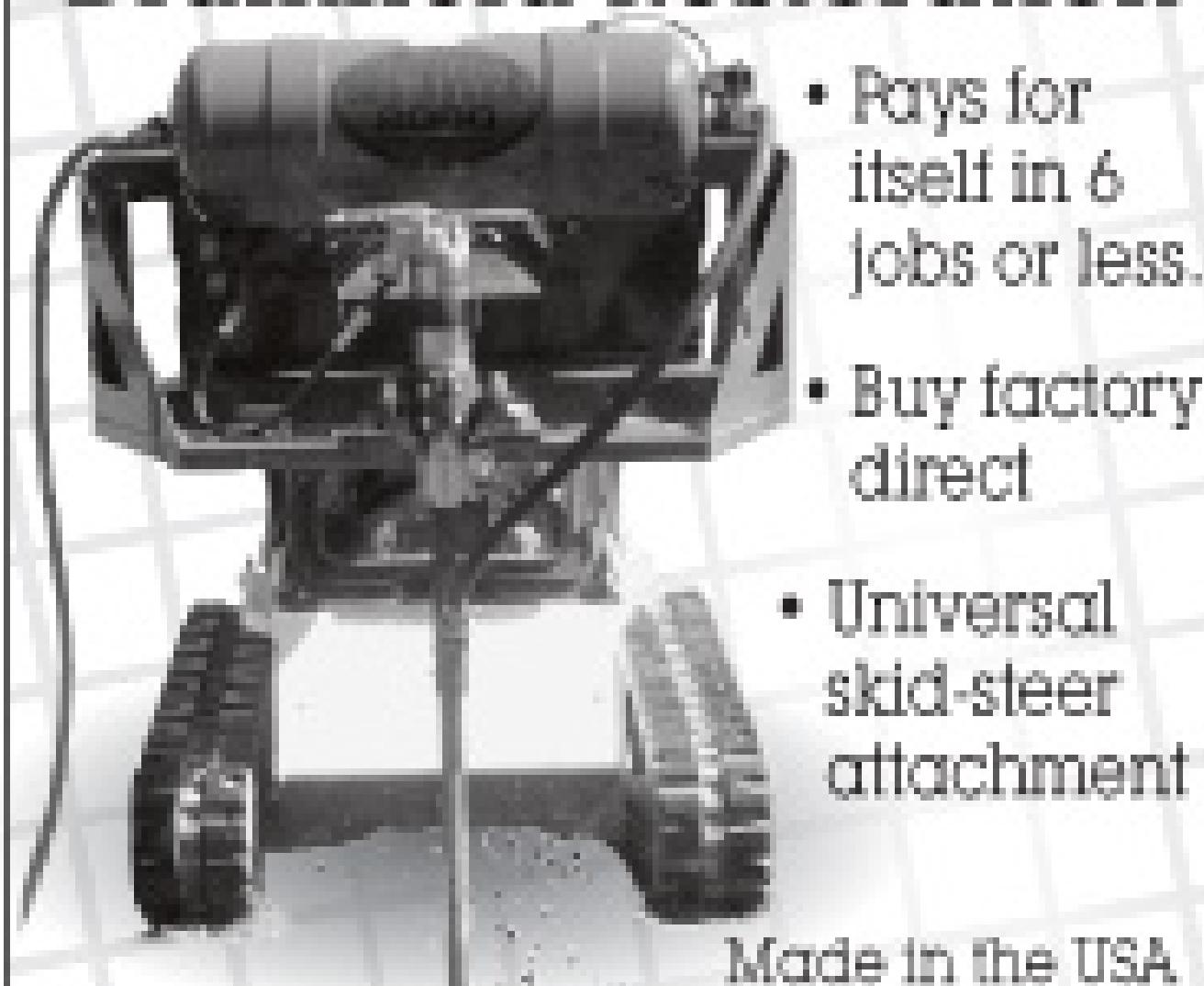

- Pays for itself in 6 jobs or less.
- Buy factory direct
- Universal skid-steer attachment

Made in the USA

Any questions feel free to call
320-293-6644
or visit our website at
www.soilshaker.com

The Amazing ARCTIC BLASTER Thawing Device

> THAWS PIPES ABOVE
& BELOW GROUND

> USE ON PLASTIC,
COPPER OR ABS

> PERFECT FOR ROOF DRAINS

ARCTIC BLASTERS INC.
SUNDRE, ALBERTA

PH: 403.638.3934
FAX: 403.638.3734

PADLOCKS

- Your Padlocks
- Your Key Number
- Any Quantity
- Best Prices

Quick-
Shipped
Anywhere!

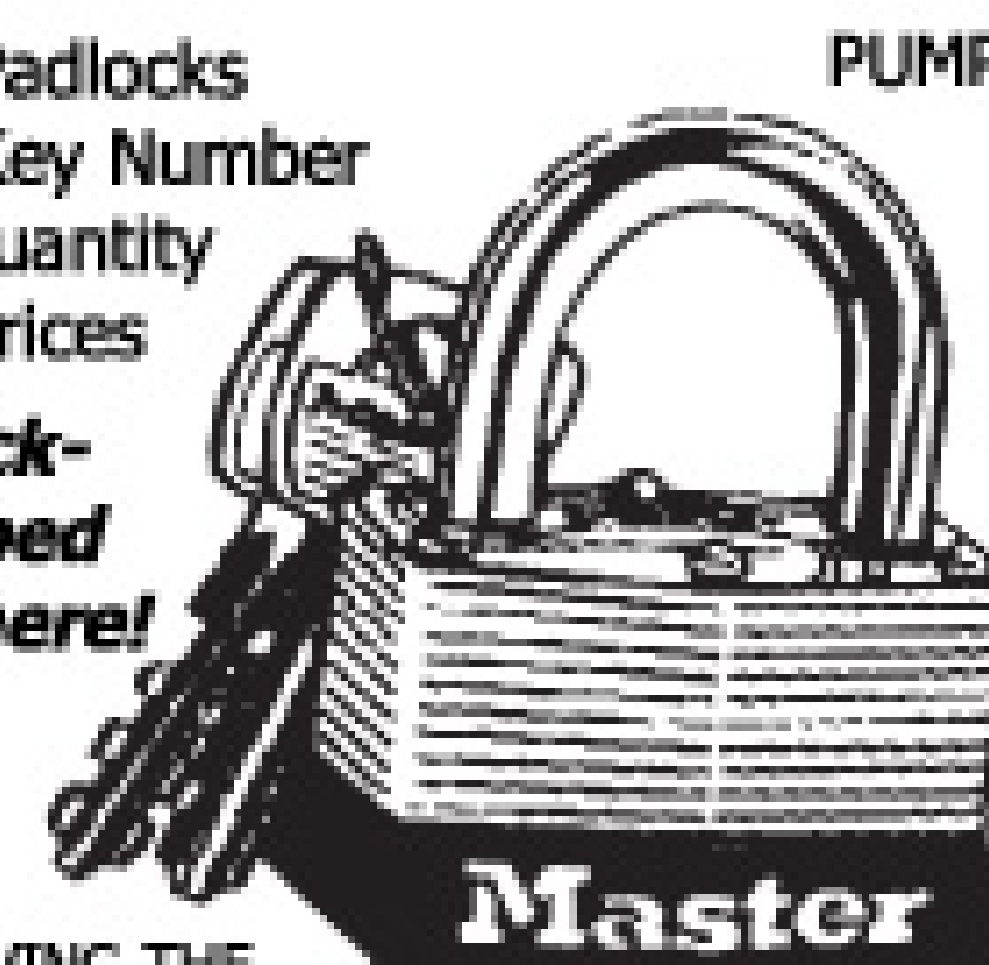

SERVING THE
PORTABLE SANITATION

INDUSTRY FOR
14 YEARS—
WE'RE THE
BETTER WAY
TO BUY PADLOCKS™

Call For FREE
CATALOG
or Instant
Quote!

LockMasters
1-800-461-0620
www.lockmastersusa.com

sales@lockmastersusa.com • Fax (850) 914-9754

Refrigerator MAGNETS

500 Minimum -
Call for
pricing



43¢
EACH!

Actual Size: 4-1/2" x 2"
1-800-758-2743
254-829-0373

2-color Imprint - Quantity Discounts



ASHLAND PolyTraps

Grease, Oil, Hair and Lint
Traps and Interceptors

- NO Rust or Corrosion
- Lightweight
- Very Cost Effective
- Sizes up to 560 Gallons
- Made in the U.S.A.!

LIFETIME WARRANTY!

Certified by U.P.C.,
IAPMO and P.D.I.

800-541-8004

PolyTraps@Amplex.net
www.ashlandpolytrap.com

WATER JETS FOR RENT



- Units from 4,000 to 40,000 psi, including convertibles
- 60-600 hp, diesel or electric
- Rent, buy or lease
- Branches in MI, TX, NJ, CA, LA

NLB Corp. 1-877-NLB-7996
www.nlbcorp.com

Pumper

see photos in COLOR at www.pumper.com

TRUCK STOP



December



1997 L-8000: 4500 gallon tank, vac and gun pumps, 18,000 front, 40,000 rear, 8.3 Cummins engine, RTF14615 trans., 640,000 miles. Call for details.
920-925-3537 CP12



1988 Ford L8000 Vac-Con: Very good tires, 9-yr. debris box, 30' of 8" vac tubes, 65 gpm @ 2000 psi, Cummins jetter motor, very well maintained, 2nd owner. ..\$25,000
606-877-2670 P12



1999 Mack: 300 hp, 8LL trans., low miles, new 80 BBL tank and Masport 400 vac pump, new paint and tires.\$62,000
3 available with other size tanks.
877-898-5104
hullstruckbodies.com P12



1997 Ford: 300 hp w/Supersucker, 17" HG 1020 blower, wet/dry.
.....Asking Only \$50,000
For More information,
Contact Sergio at
361-318-4459 CMP12



2004 Freightliner/Vactor: Auto. trans, diesel engine 1300 gal. water, 80 gpm @ 2,000 psi system, Roots 824RCS 18" 3500 cfm blower, debris body flush-out, cold weather recirc., accumulator, multi-flow system, 8' hyd. telescoping boom, tele/rotating reel, unit loaded, low hours and miles.
Call Joe 312-208-6373 P12



1986 Chevy C65 Cat: Diesel 175K, 5-speed manual split shift. New brakes and tires. Pump-Meyers D-65, 2000 lbs @ 65 GPM. One hour on rebuild. Perkins diesel. 1000 gallon tank. Good hoses and nozzles. Ready to work.\$25,000 (a steal)
770-527-0376 ICPBW



1999 Volvo: 370 hp Cummins, low miles, 8LL trans., heavy axles, heavy bumpers, new 90 bbl. tank & Masport 400 vac pump, new paint & tires, super nice truck.
.....\$59,500
877-898-5104
hullstruckbodies.com P12



1994 L-8000: 2,500 gal steel; 210 hp Cummins diesel, 306,603 miles; 6-spd. trans., 2-spd. rear axle, air brakes, 33,000 GVW, good rubber; 48" & 60" alum. toolboxes, stainless catwalks, 4" front/rear intakes, 6" discharge, brand new Masport H15W water-cooled (10 hrs); reliable truck, one owner.\$24,500
Tim 513-755-8050
mikeullman@winelco.com P12



1991 F-800 Pump Truck: New Masport pump, good rubber on tires, good starter truck. Located in GA.
678-873-0899 P12



1995 Ford/Vactor 2100: 15 yd. body, 85 gpm @ 2500 psi, PD blower, pull down pipe racks. Perfect condition.
Call Jim 707-748-7775 CP02



1994 Vactor GMC White Cabover: Cummins 6 cylinder x2, 1,000 gallons, 5 yards, dual fans, excellent condition.
.....\$70,000 OBO
Contact Bill at 1-866-744-9921 CP12



2005 9105 Terra Gator: 400 hp, 18-spd. Fuller, 1150 hrs., 4500 gal. manure tank w/Kongskilde land injector. New in 2006. 5-yr. complete warranty.\$275,000
Call Don 800-383-0003 P12



2006 Ford: LCF power stroke, 4.5 L; V6; only 8,361 miles, white, A/C, AM/FM radio, auto. trans., w/2007 Imperial PTM 1100 gal. tank; 800 gal. waste/300 gal. fresh water. Masport rotary valve vac. pump; model HXL 4DE. Water pump w/hose reel, storage boxes on both sides.\$50,000
401-364-7500 P12



1985 International: 1700 series, 5-spd., diesel, 1800 gal. tank, Jurop pump (rebuilt Jan. 2008), 60' of hose. Truck is ready to pump, used daily.\$9,000 OBO
816-238-8500
NW Missouri P12



1995 Ford F Series Pumper: Ford diesel, 10-spd. trans., Fruitland pump, Badger 3000 gal. tank, new rear suspension, good rubber. Reduced price\$18,500
800-858-3111 P01



2006 Stutsman 20,000 Gal. FRAC Tank:
.....\$26,500
Also: Houle 20" maxi-pump all on trailer and field ready.\$5,500
Call Don 800-383-0003
Cell: 515-320-0481 P12

Pumper

see photos in COLOR at www.pumper.com

TRUCK STOP



December



1989 International DT466: 2200 gal. septic truck, drop axle, 387K miles, newly painted, great condition, kept indoors. A lot of truck for the money.\$20,000
317-888-3627 PBM



2004 Ford F550 Super Duty Diesel Pump Truck: White with gray interior, Best built with a 1050 gallon stainless steel tank, PTO driven Masport pump, 75,000 miles. Perfectly maintained by Gabrielli Ford in Jamaica, NY. ..Wholesale Price of \$29,500
800-634-2085 P01



1989 Mack Tractor: 300 hp, 6-spd., 18 ft., 44 rears, only 300,000 miles, Utilite 350HD vacuum pump, 1980 5500 gal. Paisi semi trailer, 11R24.5 tires all around 90%.\$29,900
Call Judge Coleman 516-398-5638
E-mail: cwjudge@aol.com P12



2007 Mack CTP 713: 405 hp, 6-spd., auto, 20 fr., 46 rears, AM/FM/CD, air ride seats, all alum. wheels, 5,500 mi., 4000 gal. tank, 506 Challenger pump.\$135,000
Kevin @ 850-333-1651
Baker, FL P12



1984 International DT 466: Drop axle, 3,000 gallon vacuum tank, 200 gallon fresh water, 230,000 miles. Runs good; ready to work.Asking \$13,000
PA 717-369-4809 P12



2001 Kenworth: 435 hp Cat engine, 10-spd., AC, cruise, new 3600 gal. tank and Jurup R260 364 cfm vac pump, new paint and tires.\$73,000
877-898-5104
hullstruckbodies.com P12



1994 Vac-Con: Ford L8000, 103,923 miles, auto. trans., 3-stage fan blower, hydrostatic, FMC water pump @ 45 gal. @ 2000 psi.\$59,500
Bob @ 832-423-8156 PMA12C1



1994 KW T-600: 300 hp Cummins, 180K, 2500 gal. tank, large storage compartments, tires 75%, 200 gal. fresh water tank, 6" heated dump valve, stainless steel hose trays, great truck!!.....\$36,000
320-269-2920 CPBM



Shower and Restroom Trailers: Platinum and Gold Series, new and used available. Each with separate men and women sides.
CCI/Brian Touey 805-896-3777 PBM



One 1986 and one 1987 Aquatech: '86 Cat diesel engine, auto.trans., 12,000# front axles, 23,000# rear axles, 55,000 miles, Triplex rodder pump, Robuschi RB120 PD blower, front mount hose reel, hydraulic rear door locks.
Call Joe 312-208-6373 P12



1985 Ford L 9000: Fresh 350 hp Cat engine, 8LL transmission, 4,000 gal. tank, 500 cfm pump, new tires, strong productive truck.\$29,000 OBO
574-848-7704 P12



1986 Volvo 810: BOTH Cummins, 9-spd., single stage fan, great condition for age, 1500 gallons fresh, 12 yard box, must sell. Located in Downs, IL.....\$19,500
Jeff @ 309-829-0003 CP01



1991 GMC Tank: LT-10 Cummins engine, holds 18 cu. yds., newer motor w/31,010 miles. Needs new blower....\$40,000 OBO
Please email:
shatal98@yahoo.com P12



1994 Vac-Con Hi-Rail Vacuum Truck: 5016 Series. 16 cu. yds., wet or dry. Roots 1024 blower, 18' HG. DMF hi-rail setup. Remote controlled hydrostatic rail drive. Rebuilt hydrostatic drive February 2007. Repainted white 2006.\$100,000 OBO
419-666-5310 CMP12



1999 Vactor 2115/IH 2574 Chassis: Vactor 15-yd. body, 80 gpm/2500 psi pump, loaded with options. Chassis & body rebuilt. (Stock #1489) December special...\$125,000
Call Joe 312-208-6373 P12



1996 International 4700: T444E, auto, 332K, 1700 gal. tank, 225 fresh water, PTO vac pump, toilet rack.\$19,500
Call Paul 580-472-3805 P12

Pumper

see photos in COLOR at www.pumper.com

TRUCK STOP



December



1994 GMC/Volvo: N-14 Cummins, 350 hp, 52,000 GVWR, 3000 gal. tank w/150 gal. water tank outside, Jurop R260 350 cfm pump. Good truck, works every day.
.....Priced Right \$25,000
Ted @ 225-261-1015 P12



1992 Peterbilt 2115 Vector: Ext. boom, articulating reel, 2-stage fan w/5.9 L upper engine, auto. trans. Great condition, ready to work.....\$45,000
248-345-3993 P12



1991 White-Volvo with 1995 Keith Huber Berringer II: 1600 cfm, 3300 gal. tank, good condition, ready to work. Regular PMs. Great looking truck.\$80,000 OBO
214-391-1109 P12



1989 Vac-Con L8000: 9-yd., 60 gpm @ 2000 psi, tires 90%, 72,700 miles, 4990 hrs., Allison auto. trans., 5' extendible boom. Runs good.\$20,000
315-773-4135 P12



2000 Isuzu NPR with Workmate Model 750: 500 waste, 250 water, with Masport pump and Masport odor control. Good rubber, 227,000 miles. Engine has 150,000 miles. Priced to sell.....\$14,900
Call Frank King 978-452-7750 PBM



2006 Vac-Con PD: Roots 827, 12-yd., 1300 gal., 10' tele-boom, 80 @ 2000, tele-rot. reel, wireless & more! 45K miles, 1,800 hrs\$169,000 USD
Chris @ 866-737-8470 or 705-715-6886
www.q-equips.com CP12



2000 Sterling, Vac-Con V311: 3126 Cat, Cummins 3.9 Turbo Upper, Allison Auto., 20 Front, 40 Rears, 23,470 Miles, 3,309 Hrs. Vac Unit, 611 Hrs. Jetter.....\$79,900
814-696-4343 - Hollidaysburg, PA CMP12



1995 Ford L8000 Vac-Con: Brand new 3-stage fan, 60 gpm @ 2000 psi, new intake components, new front tires, rear 90%, brand new fuel control unit, fresh paint, AM/FM, CD radio, clean inside, 59,000 miles, well taken care of.....\$55,000 OBO
Tony 508-304-4102 P12



1994 Mack CH613: 10-spd., 3500 gal. vac truck, Masport H2O liquid cooled, (2) 3" inlets, 6" dump, new tires, brakes <500 miles, state inspection passed Oct. 08. Wonderful, reliable truck.\$45,000
201-388-9620 P12



1996 International 4700: Non-CDL, DT 466 diesel, Allison auto. trans., hydraulic brakes, 400/1000 Lely tank, Chandler vacuum pump, toilet carrier, good condition.\$15,000 OBO
A-1 Little John 800-786-1725 P12



1995 International: Int. 530 motor rebuilt 12-2005, 3500 gallon tank with new paint job, Masport water-cooled vacuum pump, tires 70%, 192,000 miles. One owner, garage kept. Ready for work.
610-797-0630 CP12



2007 GMC C5500: Duramax diesel, Allison automatic transmission, 1,000 gal. waste, 300 gal. fresh water, approx. 40,000 miles. Still under warranty.\$48,000
800-592-3308 P12



2001 Isuzu Toilet Truck: 17,900 GVW, mfg. by Prime tank, 600 gal. waste, 250 gal. fresh, 164,000 miles. Priced to sell.
.....\$15,900
Call Frank King 978-452-7750 PBM



1995 International 4700: DT 466 diesel, Allison auto. trans., air brakes, 500/250 split tank, Battioni vacuum pump, 7 toilet carrying capacity, good condition.
.....\$15,000 OBO
A-1 Little John 800-786-1725 P12



1998 Freightliner FL80: 3126 Cat, 300 hp 10-spd., 40 rears, 18 front, difflock, 1-axle lock, Freightliner airride, auto greaser, 3400 gal. steel tank whoist, strong, not rusty. 3 internal baffles all in good shape, Wallenstein 750 pump 3600 psi 8 gpm jetter. 2 - 200 gal. fresh water tanks. \$40,000 US
604-819-2430 PC2



Two Vacuum Tanks For Sale: Both are in fair to good condition. Please call for more photos or questions.
4,000 gallon\$3,200
3,600 gallon\$2,800
Tim 847-812-2020 P12

Pumper see photos in COLOR at www.pumper.com TRUCK STOP



December



2003 Isuzu NQR: 4 cyl. diesel, automatic trans., 174K miles, 750/300 split, Burks water pump, Conde vacuum pump, toilet carrier, good condition.\$28,000 OBO
A-1 Little John 800-786-1725 P12



1999 Sterling C-12: 10-spd., 250K miles, A/C, 90% rubber, 3150 gal. Cusco, dump type, full open, rear heated valves, alum. hose tray, SS tool boxes, Wittig pump.\$59,900
330-360-9200 P12



2002 Granite 40K Palfinger Hook Truck: 400 18 Jake, air, 20/46 camelback, pintle, 205K, 3200 gal. RO vac tank, hy. RCF500, 1 owner, excellent, extras.....\$85,000 Firm
970-390-1816 P12



1995 IH 4700: Manual transmission, 150,000 miles, 3300 gal. steel tank, hoisted, 36" rear hatch, water tank, NVE 406 pump. Immediate delivery, upgrading this winter.\$25,000
Call Burt 630-696-2100 PBM



1992 Chevrolet Kodiak: 3116 Cat diesel, auto. trans., 250 waste tank, 5.5 hp Honda elec. start motor, Conde vacuum pump, 4 toilet carrying capacity, good condition.\$10,000 OBO
A-1 Little John 800-786-1725 P12



2004 International 4300 DT 466: Air brakes, air conditioning, new 2150 gal. tank, new 400 Masport pump, liquid cooled, new tires on rear. ..Call for pricing
937-372-1113 P12



2001 Ford F-550: Powerstroke diesel, A/T, AC, 136,000, runs great. Best 600w/300f, high pressure wash. Partial trade for slide-in unit possible.....\$29,900
816-537-5723 Warren P12



2004 KW T800W: C-15, 18-spd., 246,000 miles, 4000 gallon vac tank, fresh water hauler, PTO water pump. Can be converted to vacuum truck.
Call Paul 580-472-3805 P12



Used Stainless Steel Presvac Vacuum Trailers: Various age, condition and capacity from 4,600 to 6,400 gallons. Over a dozen to choose from. Available for pick-up in Florida, Alabama and Wisconsin. Price depends on capacity and condition.
715-546-2680 CPBM



1992 White ACL64: 425 hp Cat, 8-spd. LL, Jake, 4200 gal. tank, DeMag RFW 150, 14,600# front, 44,000# rears, heated valves, runs daily, good rubber. ..\$25,000
508-886-4986 P12



1980 Vactor 810/Ford Chassis: Vactor 810 10-yd. body, 60 gpm @ 2000 psi pump, single stage fan, 35,000 miles, all functions working properly; checked out by Vactor dealer.
Call Joe 312-208-6373 P12



2005 Isuzu NQR: 4 cyl. diesel, automatic trans., 157K miles, 750/300 split, Burks water pump, Conde vacuum pump, good condition, ready to go.\$32,500 OBO
A-1 Little John 800-786-1725 P12

FOR JUST \$125

YOUR TRUCK STOP AD WILL APPEAR IN **PUMPER** and **PUMPER TRADER** and **ONLINE** at www.pumper.com and www.pumpertrader.com!

JUST GO TO

www.pumper.com **OR** www.pumpertrader.com
and fill in the **ONLINE FORM!**

By **Scottie Dayton**

INDIANA: Tire Chip Aggregate

Recycled tires starred in the Indiana Onsite Wastewater Professionals Association field day. According to the IOWPA newsletter, installers, homeowners, and county health department officials watched as Blazer Farms of Kokomo and Cole & Sons Inc. of Russiaville replaced an onsite system using tire chips in the drainfield and perimeter drain. The aggregate is approved for use by the state Department of Health.

Entech, White Pigeon, Mich., provided the media. According to the company, the aggregate holds more water and includes fewer fines than stone. Dick Blazer, owner of Blazer Farms, figured the project would require 124 tons of No. 4 stone, but used only 24 tons of tire chips. The stone alone cost \$1,700. The chips cost \$705.

Installers noted rubber material reduced skid-steer wear and tear and was easier for workers to level and rake. Blazer, who is gearing up to use tire chips in most installations, welcomes questions. Call him at 765/438-1513.

NATION: 2007 Workplace Fatalities

The 2007 preliminary Census of Fatal Occupational Injuries produced the lowest numbers since the program began in 1992. The U.S. Bureau of Labor Statistics recorded 5,488 fatal work injuries, down 6 percent from the 5,840 deaths reported in 2006. Final results for 2007 will be released in April 2009. The injuries summary is at www.bls.gov/news.release/pdf/cfoi.pdf.

Dec. 4-5

Kentucky Onsite Wastewater Association Conference, Sloan Convention Center, Bowling Green. Call 270/715-0043 or visit www.kentuckyonsite.org.

Dec. 8-9

National Onsite Wastewater Recycling Association Installer Academy, Riviera Hotel, Las Vegas. Call 800/966-2942 or visit www.nowra.org.

Jan. 8-10

Michigan Onsite Wastewater Recycling Association Conference and Exhibit, Kellogg Hotel and Conference Center, East Lansing. Call Chanin Frank at 989/773-6985, ext. 258 or visit www.mowra.org.

Jan. 13-15

Iowa Onsite Waste Water Association Conference, Polk County Convention Center, Des Moines. Call 515/225-1051 or visit www.iowwa.com.

Jan. 13-15

Ohio Onsite Wastewater Association Conference and Trade Show, Ramada Plaza Hotel and Conference Center, Columbus. Call 866/843-4429 or visit www.ohionsite.org.

Jan. 15-17

Oregon Onsite Wastewater Association Conference, Corvallis. Call Belinda Rasmussen at 541/389-6692 or visit <http://oronsite.org>.

Jan. 18-20

Pennsylvania Septage Management Association Conference, Holiday Inn, Grantville. Call 717/763-7762 or visit <http://psma.net>.

Jan. 19-21

Missouri Smallflows Organization Conference and Exhibition, Holiday Inn Select, Columbia. Call 417/739-4100 or visit www.mosmallflows.org.

Jan. 22-24

Alberta Onsite Wastewater Management Association Conference, Deerfoot Inn and Casino, Calgary. Call 780/489-7471 or visit www.aowma.com.

Jan. 23-24

Washington Onsite Sewage Association Conference, Vancouver. Call John Thomas at 253/297-2837 or visit www.wossa.org.

Jan. 26-27

Indiana Onsite Wastewater Professional Association Conference, Camp Camby, Camby. Call Scott Rexroth at 317/889-2382 or visit www.iowpa.org.

Jan. 26-28

North Carolina Septic Tank Association Conference and Exposition, Hickory Metro Convention Center, Hickory. Call Connie Stephens at 336/416-6394 or visit www.ncsta.net.

Jan. 30-31

Wisconsin Liquid Waste Carriers Association and Wisconsin Onsite Water Recycling Association Joint Convention, Marriott West Hotel, Madison. Call 608/255-2770 or visit www.wowra.com.

Feb. 5-6

Ohio Water Quality and Waste Management Conference, Holiday Inn on Lane, Columbus. Call 614/292-8571 or visit <http://setll.osu.edu>.

Feb. 11-12

Nebraska Onsite Waste Water Association Conference. Call Lee Orton at 402/476-0162 or visit www.nowwa.org.

Feb. 14-15

Utah On-Site Wastewater Association Conference, Expo Center, West Valley City. Call Carmell Burns at 435/797-3174 or visit <http://uwrl.usu.edu/partnerships/training/uowa.html>.

Feb. 25-28

Pumper & Cleaner Environmental Expo International, Kentucky Exposition Center, Louisville, Ky. Call 800/257-7222 or visit www.pumpershow.com.

March 1-4

Ontario Onsite Wastewater Association Conference and Exhibition, Sheraton Conference Centre, Richmond Hill. Call Denis Orendt at 905/372-2722 or visit www.oowa.org.

March 8-10

Pennsylvania Association of Sewage Enforcement Officers Conference, Grantville, Pa. Call 717/761-8648 or visit www.pa-seo.org.

March 18-19

Tennessee Onsite Wastewater Association Continuing Education Workshop and Annual Meeting, UAW Union Hall, Spring Hill. E-mail Scott Fellwock at scott.fellwock@nashville.gov or visit <http://onsite.tennessee.edu/TOWA.htm>.

April 6-9

NOWRA Technical Exhibition and Conference, Midwest Airlines Convention Center, Milwaukee. Call 800/966-2942 or visit www.nowra.org.

Training & Education

Pipelayer Certification

The University of Minnesota Extension is offering a three-hour workshop to accommodate a change in the state plumbing code that states all onsite system installers must be certified pipelayers, licensed plumbers, or registered apprentices to install sewer or water pipes outside of a building. The schedule:

- Jan. 28 – Fergus Falls
- March 12 – Owatonna
- March 27 – Willmar
- April 17 – Sauk Centre

Call Nick Haig at 800/322-8642 or visit <http://septic.umn.edu>.

NAWT Vacuum Truck Technician Training

The National Association of Wastewater Transporters Vacuum Truck Technician Training is Feb. 24 in Louisville, Ky. Call 800/236-6298 or visit www.nawt.org.

Minnesota

The University of Minnesota Extension has these classes:

- Jan. 5-7 – Introduction to Onsite Systems, Austin
- Jan. 8-9 – Installing Onsite Systems, Austin
- Jan. 14-15 – Pumper/Maintenance Continuing Education, White Bear
- Jan. 26 – Troubleshooting, Grand Rapids
- Jan. 27-28 – Installer Continuing Education, Fergus Falls
- Jan. 28 – Pipelayer Certification, Fergus Falls
- Feb. 2-4 – Introduction to Onsite Systems, St. Cloud
- Feb. 5-6 – Installing Onsite Systems, St. Cloud
- Feb. 9-11 – Pumping/Maintenance, Brainerd
- Feb. 12-13 – Continuing Education, Bemidji

Call Nick Haig at 800/322-8642 or visit <http://septic.umn.edu>.

North Carolina

The North Carolina Soils and On-Site Wastewater Training Academy has the following courses at Raleigh:

- Jan. 8 – Principles of Gravity System Design
- Jan. 9 – On-Site Systems Layouts

Call Joni Tanner at 919/513-1678 or visit www.soil.ncsu.edu/training.

Virginia

The following courses by the Virginia Onsite Wastewater Recycling Association are at Blackstone unless indicated otherwise:

- Jan. 7 – A to Z of Onsite Wastewater, Winchester
- Jan. 21 – Proprietary System Training
- Feb. 11-12 – National O & M Training, Loudoun
- Feb. 18 – Proprietary System Training
- April 15 – Proprietary System Training
- April 23 – A to Z of Onsite Wastewater, Fredericksburg
- May 13 – Proprietary System Training

Contact Jeff Barr at 703/771-5250 or visit www.vowra.org.

Pumper invites your state association to post notices and news items in this column. Send contributions to editor@pumper.com. ■



Tanks For Your Business

Mid-State Tank manufactures stainless steel and aluminum tanks and has become a well-known and respected supplier for the agricultural, aviation, industrial and fire services, as well as pressure/vacuum tanks.

Mid-State Tank holds an ASME stamp and is D.O.T. approved.



Booths 4000 & 4001

Mid-State Tank Co., Inc.

PO Box 317 • Sullivan, IL 61951

(800) 722-8384 • Fax: (217) 728-8384

www.midstatetank.com



ART'S TRUCKS & EQUIPMENT

View Our Entire Inventory
Online: www.artstrucks.com

3001 West Expressway 83
McAllen, Texas 78503
956.686.2326 Fax 956.686.5179

1.800.292.7007

www.artstrucks.com



1999 VOLVO Combo Sewer Truck,
VOLVO-275HP Diesel Engine, Allison 3560
Automatic Trans., A/B, A/C, 55,604 Miles,
Vac-con Sewer Cleaner, John Deere Rear
Diesel Eng., Lot #2815680 - \$75,500

**2000 STERLING Combo Sewer Cleaner
Truck,** AT Diesel Engine, Automatic Trans-
mission, A/B, A/C, Vaccon Unit, J. Deere
Rear Diesel Engine, 32,044 Miles, Lot
#2815804 - \$79,500



**1994 FORD Combo Sewer Cleaner
Truck,** CUMMINS Diesel Engine, Auto-
matic Transmission, A/B, Vaccon MDL-
V250, 20,796 Miles, Lot #2815714 -
\$45,500



**1993 VOLVO Combo Sewer Cleaner
Truck,** L-10 CUMMINS Diesel Engine, Auto-
matic Transmission, A/B, A/C, Ram Rodder
Sewer Cleaner, 115,140 Miles, Lot #2815813
- \$45,500



The Clear Choice!

effluent filters

POLYLOK™ Inc.

BEST
TECHNOLOGY



Zabel®
A Division of Polylok Inc.



See why we consistently beat the competition!

- 1 Cannot be installed incorrectly.
- 2 Will not allow direct bypass.
- 3 Have a patented Shut-Off Ball that prevents solids from leaving the tank during servicing.
- 4 Have a unique design that prevents premature clogging.
- 5 Rated for 800 GPD to 10,000 GPD.
- 6 Accept Smart Filter® Alarm to notify homeowner when the filter needs servicing.
- 7 Ideal for septic, grease traps and advanced treatment systems.

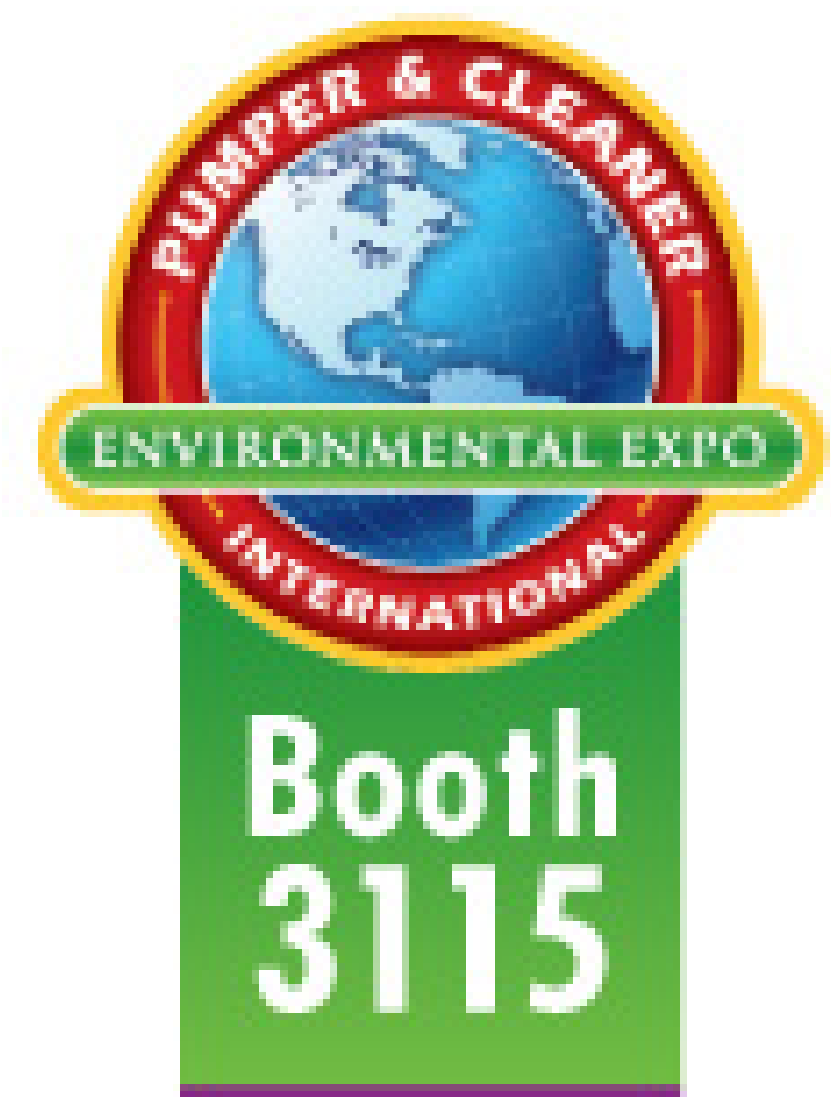

Filters play a critical role in protecting the septic system leach field. To ensure your system is designed and protected properly, insist on Polylok and Zabel Filters. We have been the Clear Choice since 1959!

See our complete line of Effluent Filters at www.polylok.com



Zabel®
A Division of Polylok Inc.

BEST
TECHNOLOGY

POLYLOK™ Inc.

Innovations in Precast, Drainage & Wastewater Products

3 Fairfield Blvd,
Wallingford, Connecticut 06492
1-800-701-3942 Fax: 203-284-8514
email: sales@polylok.com
Web site: www.polylok.com



U.S. Airmen gather together for traditional prayer prior to heading out on their daily mission ~ Baghdad.
—U.S. Navy Photo by Petty Officer 2nd Class Todd Frantom; www.defenselink.mil/

THIS HOLIDAY SEASON,
REMEMBER THEIR **COURAGE**
AND THE **SACRIFICES**
THEY MAKE FOR OUR **FREEDOM.**



www.polyjohn.com

PRESVAC

The Leader
In Vacuum
Technology

Bright finish Aluminum Tanks
for the Septic Pumping
Industry... Standard
tank models from
2,000 gallons
to 5,000 gallons.



Hydro-Trencher - 5300 CFM air flow/28" HG vacuum
with 8" hydraulic actuated boom, 3000 U.S. gal.
debris tank (stain. steel 316), 1000 U.S. gal.
water tank (stain. steel 316), 9 G.P.M. water
pump with pressures to 5800 p.s.i.

Powervac 5300 for wet/dry operation

5300 CFM air flow/28" HG vacuum, Dump chutes
extended to rear of truck, Stainless steel 316,
DOT 407/412



Liquid Truck

Designed for industrial liquid applications

www.presvac.com



Booth 1154

Nationwide Sales & Service
Call a Presvac Dealer in Your Area!

4131 Morris Drive • Burlington, Ontario, Canada L7L 5L5 • Fax: 905-681-0411

905-637-2353 • 800-387-7763